

CHAPTER 1: MOLDED PARTS, HELPFUL HINTS, HANDY NOTES

REVISIONS

From time to time, revisions to this assembly manual may be deemed necessary. When such revisions are made, you should immediately replace all outdated pages with the revised pages. Discard the out dated pages. Note that on the lower right corner of each page is a "revision date". Initial printings will have the number "0" printed and the printing date. All subsequent revisions will have the revision number followed by the date of that revision. When such revisions are made, a "table of revisions" page will also be issued. This page (or pages) should be inserted in front of the opening page (this page) of each affected chapter. A new "table of revisions" page will accompany any revision made to a chapter.

Arrows

Most drawings will have arrows to show which direction the parts are facing, unless the drawing itself makes that very obvious. "A/C UP" refers to the direction that would be up if the part were installed in a plane sitting in the upright position. In most cases the part shown will be oriented in the same position as the part itself will be placed during that particular assembly step. However, time goes on and changes are made, so careful attention should be paid to the orientation arrows. That old cartoon of the guy agonizing over the plans for his canoe, built one end up, one end down, should not happen in real life. Especially to you.

CONTENTS

1. INTRODUCTION
2. DRAWING LIST
3. SPECIAL PARTS, TOOLS & SUPPLIES LIST
 - A. PARTS
 - B. TOOLS
 - C. MATERIALS & SUPPLIES
4. PROCEDURE
 - A. CLEANING, CARE & HANDLING OF PARTS
 - B. JOINT DESCRIPTION
 - C. TRIMMING PROCEDURE
 - D. DRILLING ALIGNMENT HOLES
 - E. REMOVING THE PROTECTIVE COATING (PEELPLY)
 - F. FASTENING PARTS TOGETHER
 - G. FIBERGLASS STRIP INSTALLATION

1. **INTRODUCTION**

The purpose of this chapter is to familiarize you with the parts to the kit, the tools you will be using, some techniques that may be helpful and the material that is required to build your 320FB. While you will not perform any work in this chapter other than reading and examining some of the parts that came with your kit, **PLEASE READ** this chapter completely. It will demonstrate some techniques that will save you a lot of time in the months ahead, and provide a lot of cautions and warnings that will make your plane safer and better.



2. DRAWING LIST

- 1-1 Page 1-4 The Pre-Molded Parts
- 1-2 Page 1-9 Reinforced overlapping Joints
- 1-3 Page 1-9 Trimmed Parts
- 1-4 Page 1-10 Trimming Procedure
- 1-5 Page 1-11 Shearing Joggle
- 1-6 Page 1-12 Drilling alignment holes
- 1-7 Page 1-14 Cleco and Cleco Pliers
- 1-8 Page 1-18 Hysol Structural Adhesive
- 1-9 Page 1-19 Removing Excess Epoxy/adhesive
- 1-10 Page 1-21 Joining parts -Fiberglass strip installation
- 1-11 Page 1-22 Preparing seam for BID tape
- 1-12 Page 1-23 Preparing BID strips
- 1-13 Page 1-24 Cutting Fiberglass on a Bias
- 1-14 Page 1-25 2 BID Sandwich
- 1-15 Page 1-26 Stippling Brush



1-3

Chapter 1

REV.

0 / 11-1-91



3. EQUIPMENT REQUIRED: Special Parts, Tools & Supplies Lists

3.A. Parts:

Your kit contains several parts that are already formed for you:

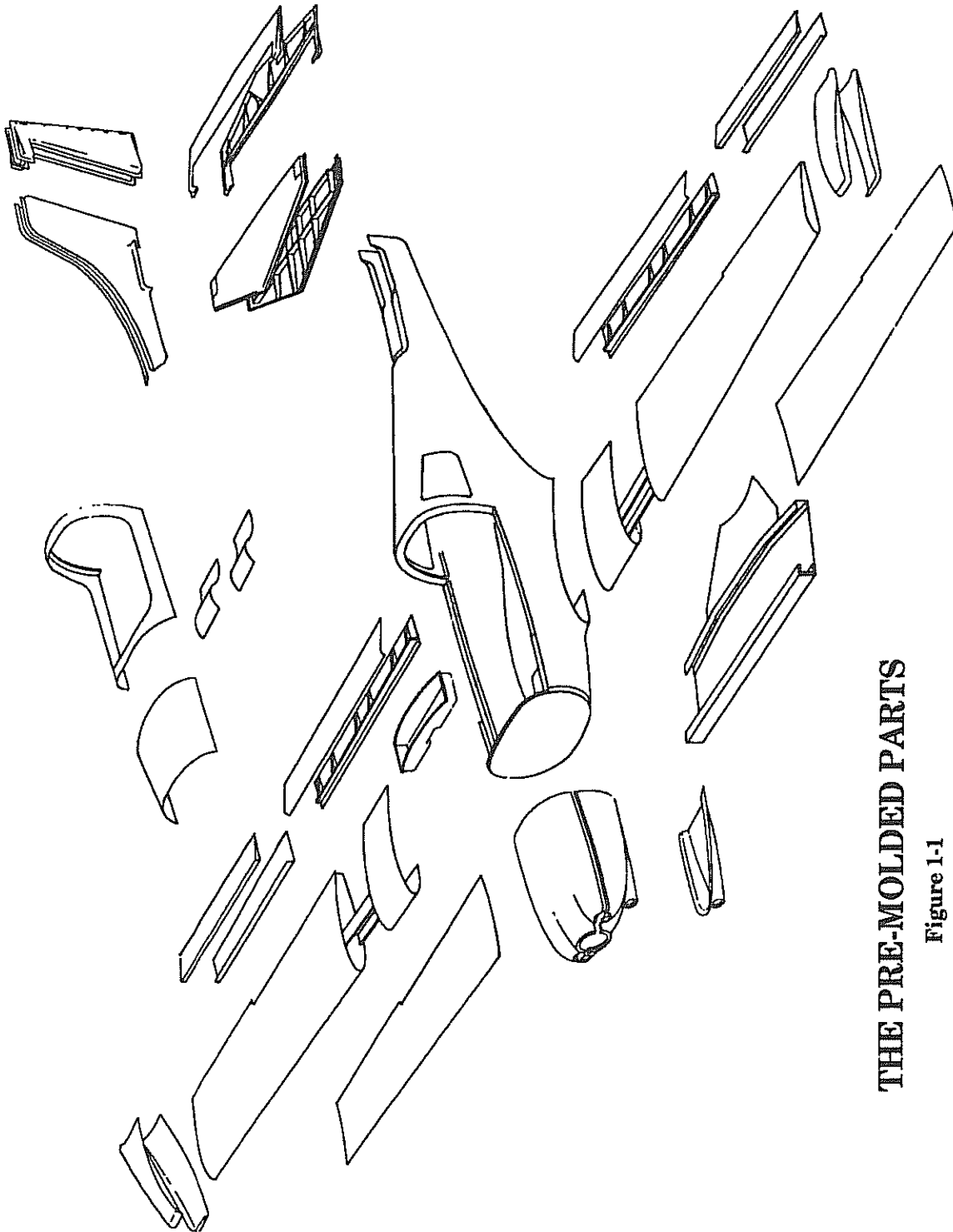

THE PRE-MOLDED PARTS

Figure 1-1

3.A. Parts:

Fuselage
L.H. Bot Elevator
R.H. Top Aileron
R.H. Rudder
R.H. Top Inbd Wing
R.H. Bot Aileron
L.H. Rudder
Horiz Stab Top
L.H. Top Aileron
Fwd Deck
L.H. Top Inbd Wing
L.H. Bot Aileron
Top Cowl
Horiz Stab Bottom
R.H. Wing Tip, Top
Bottom Cowl
R.H. Top Outbd Wing and Spar
L.H. Wing Tip
Canopy Frame
R.H. Bot Outbd Wing
R.H. Vert Stab
Bot Butterfly with Fwd & Aft Ctr Spars
L.H. Top Outbd Wing and Spar
L.H. Vert Stab
L.H. Bot Outbd Wing
R.H. Wing Tip, Bot
Lower Cowl Scoop
R.H. Top Flap
L.H. Wing Tip, Bot
R.H. Top Elevator
R.H. Bot Flap
Header Fuel Tank
R.H. Bot Elevator
L.H. Top Flap
L.H. Top Elevator
L.H. Bot Flap
Nose Wheel Well



3.B. Tools

- Sheet Metal Shears
- Pencil compass or equivalent marking tool
- Utility knife or equivalent
- Saw Horses (3)
- Adhesive measurement syringes or balance scale or Epoxy Dispensing Pump
- Small weigh scale (should be capable of measurements as fine as .1 oz)
- #6x 3/8 sheet metal screws or 1/8" dia, about 1/4" material capacity clecoes and cleco pliers
- Rubber gloves or protective hand coating
- Watch or clock
- 1/8" dia drill bit
- Drill motor, with the following bits:

3/32"	1/8"
1/4"	5/16"
3/8"	7/16"
1/2"	19/32"
#40	#32
#30	#19
#12	
- Reamer, 1 5/8", straight flute
- Pop rivet gun
- Dremel™ high speed moto tool, with tungsten carbide cutter
- Cleco pliers and clecoes
- Belt sander - table type with rotary sander
- Rotary cutter (looks like a pizza cutter but *isn't*)
- Hot glue gun
- Heat gun
- Jig saw
- Rivet squeezer
- Rubber squeegees
- 2' & 4' carpenter's levels
- Digital smart level
- C-clamps, 2", 4" and 6"
- Tubing benders
- 37° flaring tool
- Grinder
- Makita model 9030 1" belt sander (or similar)



3.C. Materials & Supplies

- Hysol 9339 Structural Adhesive (supplied in kit)
- Mixing sticks - tongue depressors (supplied in kit)
- Mixing dish or cup (supplied in kit)
- #40 and #80 grit abrasive paper
- Paper toweling or cloth pieces
- Wax and silicone remover (available at auto body or paint shop)
- Methylene Chloride (MC) cleaner
- Soft aluminum pop rivets, 1/8" dia., 3/8" grip



1-7

Chapter 1

REV.

0 / 11-1-91



4. PROCEDURE

4.A. Cleaning, care and handling of parts

1. Cleaning Parts

You will find instructions calling for the usage of cleaning agents throughout this manual. We have found that Methylene Chloride (MC) cleaner is very good in its ability to remove impurities from surfaces. As with all cleaners, be sure to read and follow the safety directions. Acetone is a good cleaner but Methylene Chloride (MC) is superior. *MEK should not be used.*

2. Storage of Pre-Molded Parts

The manner in which your pre-molded parts are stored is very important. Care and thought should be exercised when laying pre-molded parts away for some future use which could be months away. Try to store these parts in a position that won't produce any distorting forces (i.e., store them supported in a position as close to actual use orientation as possible). The assembled fslg should be rested on saw horses from the wing fillets and tail cone.

3. Honeycomb prepreg Panels

All ribs and bulkheads that are pre installed into your Fast-Build kit utilize the normally optional prepreg/honeycomb panels. All additional ribs and bulkheads can be made with either the standard foam and glass materials supplied (as standard) or if you choose, you can purchase additional prepreg panel sheets.

The prepreg honeycomb panels are available in two types: 3/8" core + 2 BID per side and 1/4" core + 1 BID per side. All BID ply schedules must remain the same when using prepreg panels (i.e., if a part calls for 6 BID on one side and 2 BID on the other side, the 2 BID honeycomb panel will require 4 additional BID on the first side). Also, all attachment BID schedules must remain the same (i.e., if plans call for a 6 BID attachment, then 6 plies (wet layup) must be used.) Typically 1-1/2" contact on each surface unless otherwise noted is sufficient.

If you choose to build with these prepreg materials, the purchase of one sheet (4' x 8') of each type is generally sufficient to complete the airframe. Note that the foam and E-glass is supplied already as standard with your Fast-Build kit.



4.B. Joint Description:

Adjoining parts are attached with bonded, overlapping joints (joggles) reinforced with fiberglass strips, see Figure 1-2. Figure 1-3 shows the overlaps prior to assembly (the dimensions shown in the figures are approximate). As supplied, the part edges may have excess material. To obtain the dimensions shown the excess material must be trimmed by the builder as explained in Paragraph D-4.

REINFORCED OVERLAPPING JOINTS

Figure 1-2

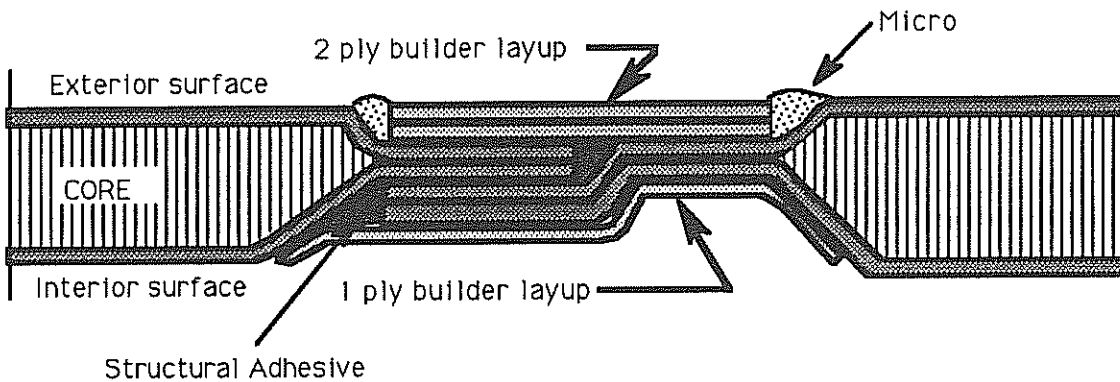

TRIMMED PARTS

Figure 1-3

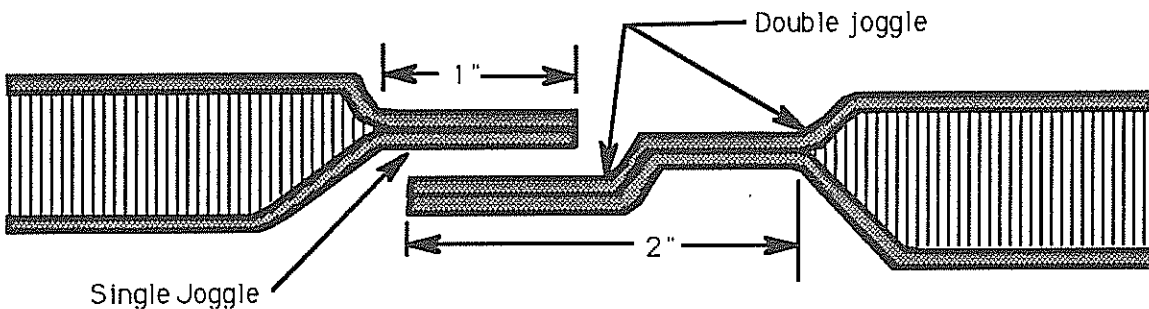

Note: Before trimming, single and double joggled surfaces may look similar. To learn what each looks like, examine the front of the fuselage. The joggle that is forward of the firewall, where the bottom cowl will meet, is an example of a single joggle. The area above and behind the firewall, where the forward deck will mount, is a double joggle.

CAUTION

**EDGES OF PARTS MAY BE SHARP. HANDLE WITH CARE,
USE GLOVES OR FILE OFF SHARP EDGES.**

4.C. Trimming Procedure

1. Place the fuselage on a convenient working surface. Mark a line on all joggle surfaces as shown in figure 1-4a. A marking tool can be made from a piece of wood, a nail and a pencil. Make sure the nail tip is well rounded and has no sharp edges which could damage the glass fibers during use. On double joggled surfaces, mark a line as shown in figure 1-4b.

TRIMMING PROCEDURE

Figure 1-4

Marking Trim Line, SINGLE JOGGLE

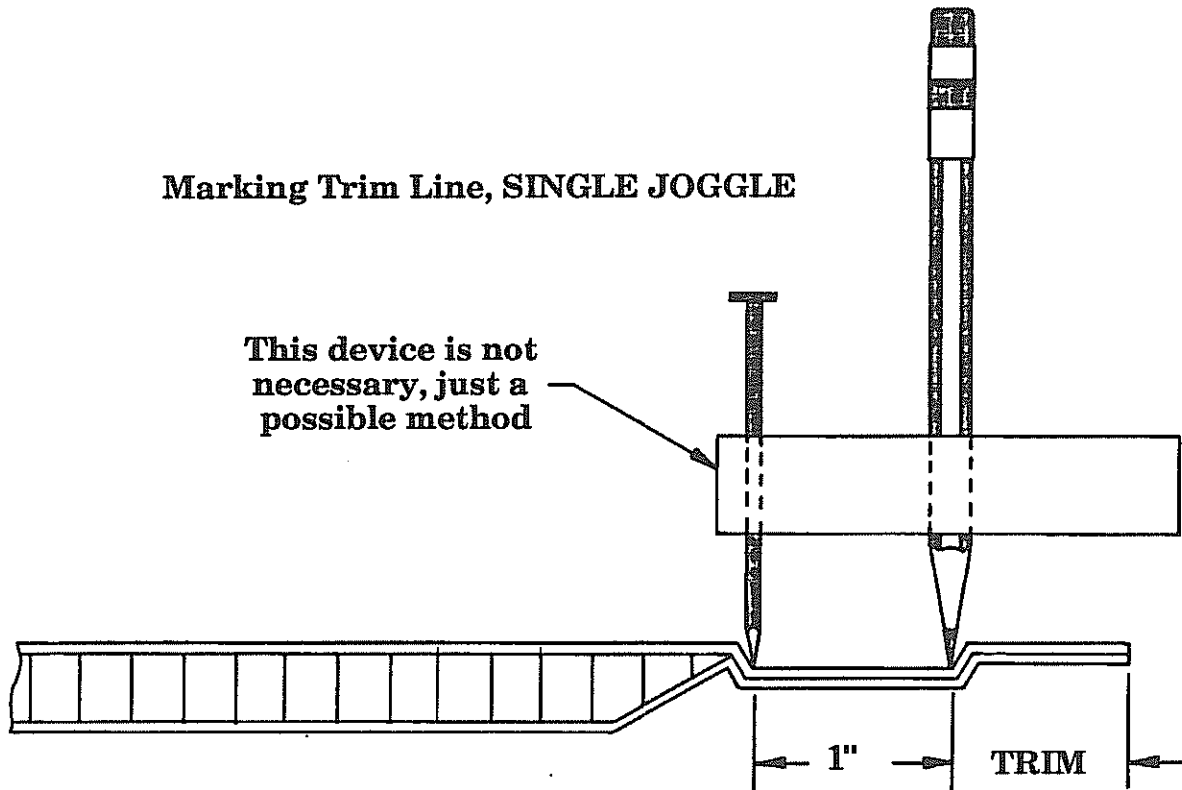

Marking Trim Line, DOUBLE JOGGLE

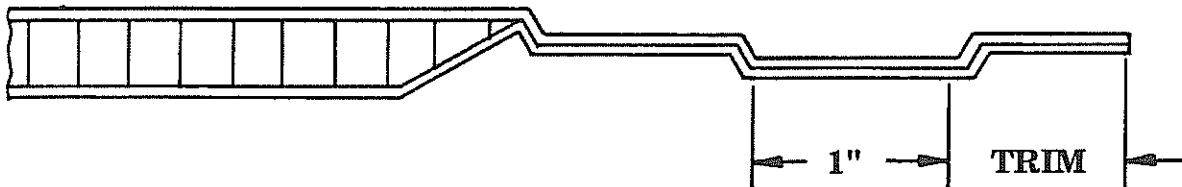

4.C. 2. Using the shears, cut along the lines. Refer to Figure 1-5 for proper appearance of the edge after trimming. If necessary, trim additional material to obtain correct edge shape. Sanding may be used for a final trimming and to smooth the edge.

3. Repeat this trimming procedure for all joggles.

SHEARING JOGGLE

Figure 1-5

This is the inner joggle edge, measure out 1" for your cut line. The double joggled parts work similarly.

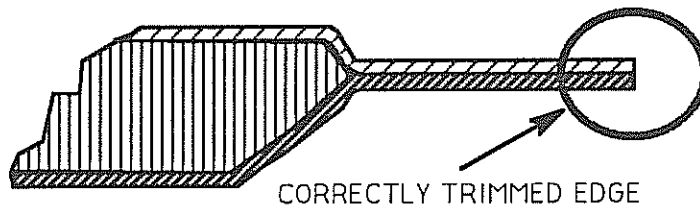
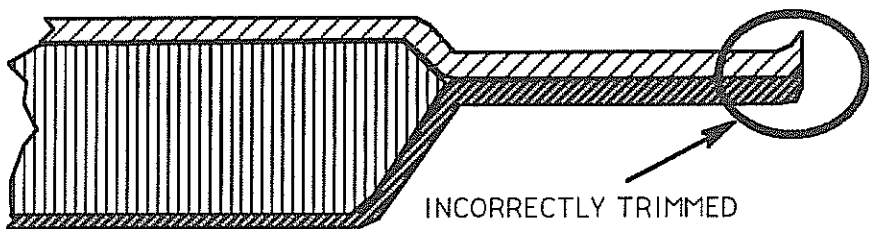
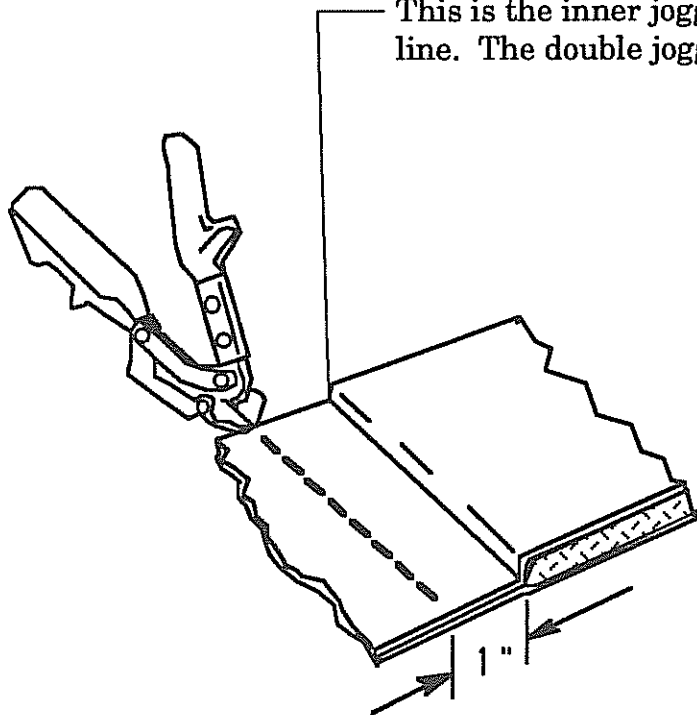

4.D. Drilling Alignment Holes

1. Equipment required

- Electric drill
- 1/8" Drill bit

2. Procedure

• To obtain proper overlap alignment at assembly, holes are drilled for screws or clecoes, which are placed in these holes to hold the parts in proper alignment during cure time.

• Using a 1/8" drill bit, drill alignment holes in the two parts to be joined (See Fig. 1-6).

• Place screws or clecoes in the alignment holes, and drill the rivet holes every 2" in between alignment holes.

DRILLING ALIGNMENT HOLES

Figure 1- 6

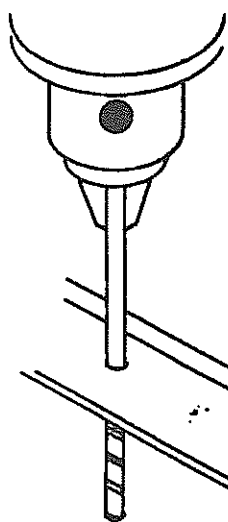

Drill alignment holes, as far apart as is practical, with 1/8" bit. After parts are temporarily clecoed together, you'll drill rivet holes (1/8") every 2" along seams

NOTE: The pop rivets are only used as a clamping device, and will be drilled out after bonding.

4.E. Removing the Protective Coating (Peelply)

Description of Parts

Molded parts are shipped with a protective coating of "peel ply" material on their inner surfaces. This material will interfere with bonding and must be removed. The peel ply usually sticks out from the edge of a part in at least one area and looks like white cloth. Where the peel ply meets and lays on the part surface it becomes transparent.

WARNING

ALL PEEL PLY MUST BE REMOVED FROM BOND AREAS TO OBTAIN GOOD BONDS. BONDING OR LAYING FIBERGLASS OVER PEEL PLY COULD RESULT IN STRUCTURAL FAILURE.

Most of the peel-ply has already been removed from your pre-molded parts, but some may remain.

Peel ply is removed by hand. It can require considerable force to pull the peel ply off in some places. As it is pulled off, it usually tears off in odd shaped pieces. Use the utility knife to pick up a new edge when necessary. **Use care not to cut into the glass of the parts.**

The white cotton strips running irregularly on the surface of the peel ply are required by the manufacturing process. These will come off with the peel ply but more pulling force will be required.

4.F. Fastening parts together

1. When parts are to be fastened together using epoxy or structural adhesive, they must be held tightly in position until the bonding material has set. Several methods are available, but pop rivets remain the best way to be sure of a proper bond. Typically, the bonding sequence is:

The parts are prepared for bonding -

- a. peel ply is removed
- b. joggled surfaces are trimmed
- c. alignment holes are drilled
- d. sheet metal screws or clecoes*(Figure 1-7) are installed into these holes to hold the parts in alignment while holes are drilled about every 2" for pop rivets.

*Clecoes™ are a sheet metal fastening device used extensively in the aircraft industry (refer to Figure 1-7). A special pair of pliers (cleco tool) is used. The tip of the cleco is inserted into the alignment hole. When the pliers are released, the cleco locks itself into the holes, holding the parts tight together. Clecoes and cleco pliers are available from aircraft supply stores or catalogs (ours included). Surplus clecoes can be purchased cheaply, and only about 15 are needed for the construction of your plane.

NOTE

Either sheet metal screws or clecoes are used as fasteners. If the fastener you will use *has grease, oil or other such contamination, it must be thoroughly cleaned before use to prevent contamination of surfaces which will be bonded later. Methylene Chloride may be used as a cleaning fluid.*

Cleco and Cleco Pliers

Figure 1-7

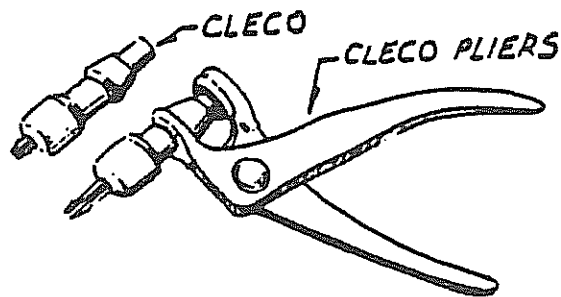

Squeeze the pliers and the grippers extend and come together. Insert into the hole, press parts together, and release the cleco. The grippers will spread, holding the parts together.

4.F.1. e. The surfaces to be bonded must now be cleaned since they may have become contaminated during handling and storage. The screws or clecoes are removed and the surfaces to be bonded are cleaned thoroughly with wax and silicone remover, acetone or MEC.

WARNING: FAILURE TO FOLLOW CLEANING STEPS CAN RESULT IN EVENTUAL BOND FAILURE. EVEN SURFACES WHICH APPEAR CLEAN MUST BE CLEANED SINCE NOT ALL CONTAMINANTS ARE OBVIOUS.



FOLLOW CAUTIONARY LABEL ON THE WAX AND SILICONE REMOVER CONTAINER. WAX AND SILICONE REMOVER IS FLAMMABLE AND MUST BE KEPT AWAY FROM SPARKS, HEAT AND OPEN FLAMES. HARMFUL OR FATAL IF SWALLOWED. DURING USE AND UNTIL ALL VAPORS ARE GONE: KEEP AREA WELL VENTILATED AND DO NOT SMOKE. EXTINGUISH ALL FLAMES, PILOT LIGHTS AND HEATERS. TURN OFF STOVES, ELECTRICAL TOOLS AND APPLIANCES THAT COULD ACT AS AN IGNITION SOURCE. VAPOR IS HARMFUL. AVOID BREATHING VAPORS AND USE ONLY WITH ADEQUATE VENTILATION. AVOID SKIN AND EYE CONTACT. WEAR RUBBER GLOVES OR SUITABLE PROTECTIVE SKIN BARRIER. WASH HANDS IF THEY COME IN CONTACT WITH THIS LIQUID. IF SPILLED ON CLOTHING, REMOVE AND LAUNDRER BEFORE RE-USING.

f. Dampen one cloth or piece of toweling well with the wax and silicone remover and wipe it along the bond surface of either part. Do not rub or scrub the surface as that may work the contaminants into the surface. Follow within seconds with a dry cloth or toweling piece to absorb the solvent and the contaminants it removes from the bonding surface.

g. Continue that process until that seam has been cleaned. Then replace both the wetting and drying cloths with new pieces and repeat the cleaning process for the other half. If at any time the wetting or drying cloth shows any soiling or the drying cloth becomes wet, replace it immediately with a dry one.

h. If any obvious contaminants still remain, the above process may be repeated with methylene chloride.

WARNING: FOLLOW CAUTIONARY LABEL ON THE METHYLENE CHLORIDE CONTAINER. METHYLENE CHLORIDE IS A VOLATILE SOLVENT. CAUSES IRRITATION OF THE EYES, SKIN AND RESPIRATORY TRACT. PROLONGED BREATHING OF VAPOR CAN CAUSE LOSS OF CONSCIOUSNESS. DO NOT GET IN EYES, ON SKIN, ON CLOTHING. DO NOT TAKE INTERNALLY. AVOID BREATHING OF VAPORS. WHEN HANDLING WEAR CHEMICAL SPLASH GOGGLES, PROTECTIVE CLOTHING AND SOLVENT RESISTANT GLOVES. WASH THOROUGHLY AFTER HANDLING. USE ADEQUATE VENTILATION IN WORK AREA.

 LANCAIR® 320FB	1-15	Chapter 1	REV. 0/ 11-1-91	
---	------	-----------	-----------------	---

- 4.F.1. i. After the seam is cleaned, repeat the cleaning process for the other part.
- j. Using clean #80 grit abrasive paper roughen all cleaned surfaces lightly until the surface shows a fine white powder. Remove the powder with a clean cloth or clean brush.
- k. The bonding material (epoxy, epoxy/flox, epoxy/micro or structural adhesive) is prepared and applied to one or both surfaces to be bonded

WARNING

THE CONTAINERS USED TO MIX THE ADHESIVE MUST NOT BE WAX COATED. THE WAX COATING COULD CONTAMINATE THE ADHESIVE AND REDUCE THE BOND STRENGTH. LIKEWISE, THE MIXING CONTAINER MUST BE FREE OF DIRT, GREASE, OIL OR OTHER SIMILAR CONTAMINANTS.

WARNING

READ THE CAUTIONARY LABEL ON THE EPOXY CANS. THIS EPOXY IS EXTREMELY IRRITATING TO THE EYES AND CAN CAUSE PERMANENT EYE DAMAGE. MAY ALSO CAUSE SKIN IRRITATION OR SENSITIZATION REACTION IN CERTAIN INDIVIDUALS. PREVENT EYE AND SKIN CONTACT WITH EPOXY MATERIALS. AVOID BREATHING VAPOR. USE ONLY IN WELL VENTILATED AREA. AVOID INHALATION OR EYE CONTACT WITH DUST FROM GRINDING OR SANDING OF CURED EPOXY. REMOVE CONTAMINATED CLOTHING AND LAUNDRER BEFORE RE-USE.

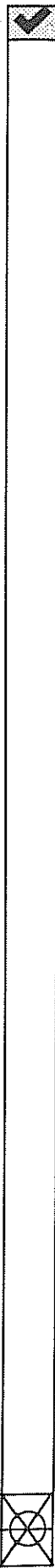

4.F.2. If structural adhesive is to be used, prepare it as follows:

HYSOL 9339 Epoxy can be mixed in the proper weight ratio only by using a good scale. A small calculator will help, too. **IMPROPER MIXING CAN SPEED OR SLOW CURE TIME AND DECREASE ADHESIVE STRENGTH. ATTENTION TO THE MEASURING PROCESS IS IMPORTANT.**

Hysol Structural Adhesive

Figure 1-8

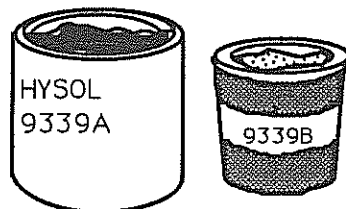

The mixing ratio for Hysol 9339 is 100:44.5, part A to part B. The easiest way to do this is put the mixing cup on the scale and record its empty weight. Guessing at how much epoxy you will need for the job, take about 2/3's of that amount from the Part "A" can and put it in the cup, weigh, and subtract the weight of the empty cup from the new weight, giving you the weight of just the epoxy in the cup. Multiply the weight of the epoxy in the cup by 1.445. Add the weight of the cup to this figure, and now add Part "B" until the cup weight is the same as your calculated figure. Maintaining nearest 1/10oz. is plenty close enough.

a. Example:

1. Weight of empty cup: .5 Oz
2. Weight with 2/3's (estimated) of the material you'll need, Part "A": 3.7 Oz.
3. Weight of Part "A": 3.2 Oz
4. Multiply by mix ratio 100:44.5: X 1.4
5. Total weight of Part "A" and Part "B" needed is: 4.6 Oz
6. Add the weight of the cup back in .5 Oz
7. The total weight, once you've added the proper amount of Part "B": 5.1 Oz.
8. Add Part "B" to the cup until it weighs 5.1 Oz, mix, and you're ready to go.

b. Mix the Hysol 9339 epoxy adhesive components as follows:

1. Read all the instructions and information on the epoxy cans. Temperature of the adhesive ingredients and the surrounding room temperature must be 60°F or more.

2. The 9339 adhesive has a working life of 2 hours at 77°F however, at higher temperatures or with a larger batch this working life will be considerably less. Therefore, before mixing adhesive, all necessary equipment should be ready.

3. For the same reason, it is better to mix too much adhesive than too little. If you run out and must mix a second batch, the first batch may have already begun to thicken making it difficult to compress the seam properly and possibly reducing bond strength when cured.

Another reason for mixing more than you need - If you have a little left over, leave it in the corner of the cup with the mixing stick in it. Because cure time varies with temperature, by leaving a little in the cup and leaving the cup near the part you have epoxied, the cup can now be used as your test for curing. Wait at least 24 hours after joining parts. Then, before touching parts, try to move the stick around in the epoxy in the cup. If you can move it at all, your parts are not cured, either. Wait another 24 hours and repeat. Handling parts before cure is complete can reduce the bond strength, and should be avoided.

The epoxy cure time depends on the temperature during cure time. Because of the fire hazards involved with most heaters, it is not recommended to have a heater operating in the room that could cause a fire. However, getting the room nice and warm before applying adhesive, so the parts and air temperature is above 77°F, will help shorten cure times, but remember it will also shorten the pot life/working time of the adhesive.

4.F.2.B.3.(a) Estimate the amount of adhesive that you will need for the first seam and measure a sufficient amount of Part "A" and "B" to make that amount.

(b) Using a mixing stick, thoroughly mix the two parts for at least two minutes. Longer for larger batches. Occasionally scrape unmixed material from the sides of the cup. Uniform blue-gray color will result.

(c) Apply the structural adhesive as follows (the following assumes the seams have been cleaned and sanded as previously described. If not, do so at this time).

(1) Beginning with the seam of the first part you have chosen to start on, with a wood spatula, spread an even layer of adhesive on the overlap surface of the part. Repeat the adhesive application process on the overlap surface of the other part.

(2) Overlap the two adhesive coated surfaces and align the holes in the surfaces. Insert a screw or cleco into a hole at each end of the part, or every foot along the part if it is longer than 18". Starting at either end, insert rivets into the pre-drilled holes and form the heads (backup washers are normally not necessary).

(d) Remove the fasteners and place rivets into those holes.

(e) While the adhesive is still soft, scrape off the excess that squeezes out (Fig. 1-9). *Adhesive is much harder to remove when hardened.* Use methylene chloride on a clean cloth to remove adhesive that smears on the fiberglass surface. Clean adhesive from the clecoes if any were used.

Removing excess epoxy/adhesive

Figure 1-9

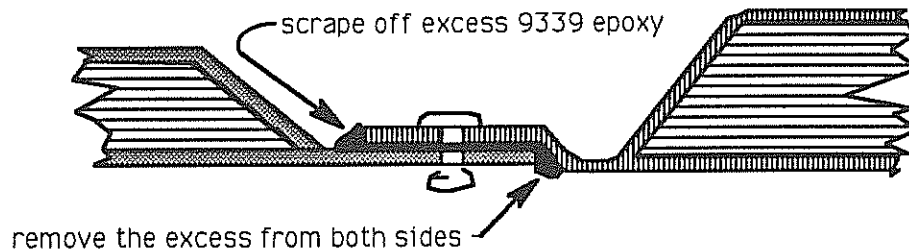

Make sure you're wearing work clothes, since the adhesive may drip on you. Also check for adhesive on hair, arms, etc., and wipe it off before it cures. A long sleeve shirt and long pants are highly recommended.

4.F.2.b.3. (f). Wait at least 24 hours, then test your mixing cup residue for cure. If solidly cured, then the part should be ready to start work on once more. Drill out the rivets using a 1/8" drill, and remove any loose pieces.

(g). Fill the rivet holes with a 50/50 mix of micro/flox, cleaning off any excess, let harden, and you're done with the seam. To make things a little neater, you can put a piece of tape over the back side of the seam, covering the bottom of the rivet holes, to help contain the filler mix and make a smoother neater finish, that requires less epoxy (and adding less weight, something to think about all through the construction process).

4.F.3. Epoxy

a. Mixing epoxy: As with the structural Adhesive, you can use a scale for measuring the proper amount of laminating resin and hardener. There are also some good measuring pumps on the market that would probably pay for themselves (about \$190.00) since you'll waste less epoxy with them, and have less chance of spills or improper mixes. We offer one in our catalog that has performed well here in our own shop for years now.

Typically, you will be using from 1 to 6 ounces at a time.

If you prefer to use a scale instead of a dispenser, you can measure the two parts as you did for the Hysol, except use 1.44 in stead of 1.445.

Another way is (*Epolite resin system used here for example purposes only. Use the appropriate ratios for your supplied system of resins.*)

- (1) Place your empty cup on the scale.
- (2) Record the weight of the empty cup.
- (3) Estimate to amount of epoxy you will need.
- (4) Add .44 oz of hardener (yellowish) to cup for each 1-1/2oz you'll need
- (5) Pour 1 oz of resin (clear) into cup for each .44 oz of hardener and mix thoroughly.

4.F.3.b. Working time can be as short as twenty minutes if it is hot, so be sure everything is in place and ready to go before you begin mixing.

c. As with the Hysol, the surfaces must be totally free of oil, grease or other contaminants, and slightly roughened. Fasten with pop rivets, let harden, remove fasteners & fill holes.

NOTE: USE CARE TO MIX YOUR RESINS AND ADHESIVES ACCORDING TO THE MANUFACTURER'S INSTRUCTIONS FOR THE PARTICULAR SYSTEM YOU ARE USING - THEY ARE ALL DIFFERENT, AND AN IMPROPER MIX RATIO COULD RESULT IN IMPROPER BONDING - OR NO BONDING AT ALL...

BE CAREFUL - PAY ATTENTION TO THE MANUFACTURERS INSTRUCTIONS!!!



1-20

Chapter 1

REV.

0 / 11-1-91



4.G. Fiberglass Strip Installation

1. Description

To stiffen joints and provide a double bond, fiber glass strips are laid over the bonded seams as shown in the sequence of drawings in figure 1-10A-F.

Joining Parts

Figure 1-10

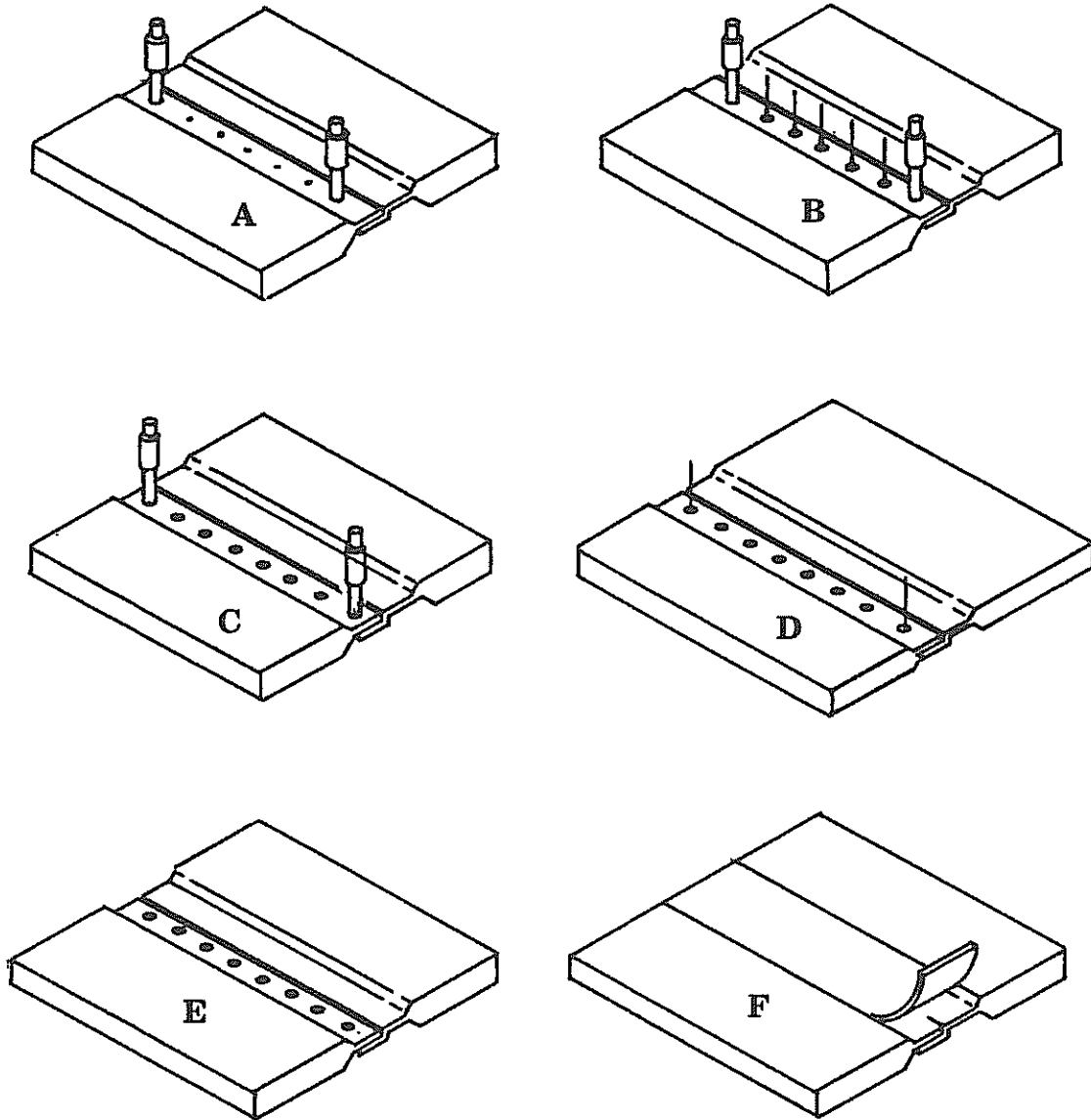

- 4.G.1. a. Figure 1-10A shows the two pieces to be joined. After the adhesive has been placed along the inside of both pieces to be joined, the two clecoes were installed to hold the parts in alignment.
- b. Figure 1-10B shows pop rivets set into the other holes drilled 1" apart for the length of the seam.
- c. Figure 1-10C shows the pop rivets after being compressed
- d. In figure 1-10D, the two clecoes have been removed and replaced with pop rivets awaiting compression.
- e. Figure 1-10E displays the two parts, waiting patiently for the adhesive to cure.

Preparing seam for bid tape

Figure 1-11

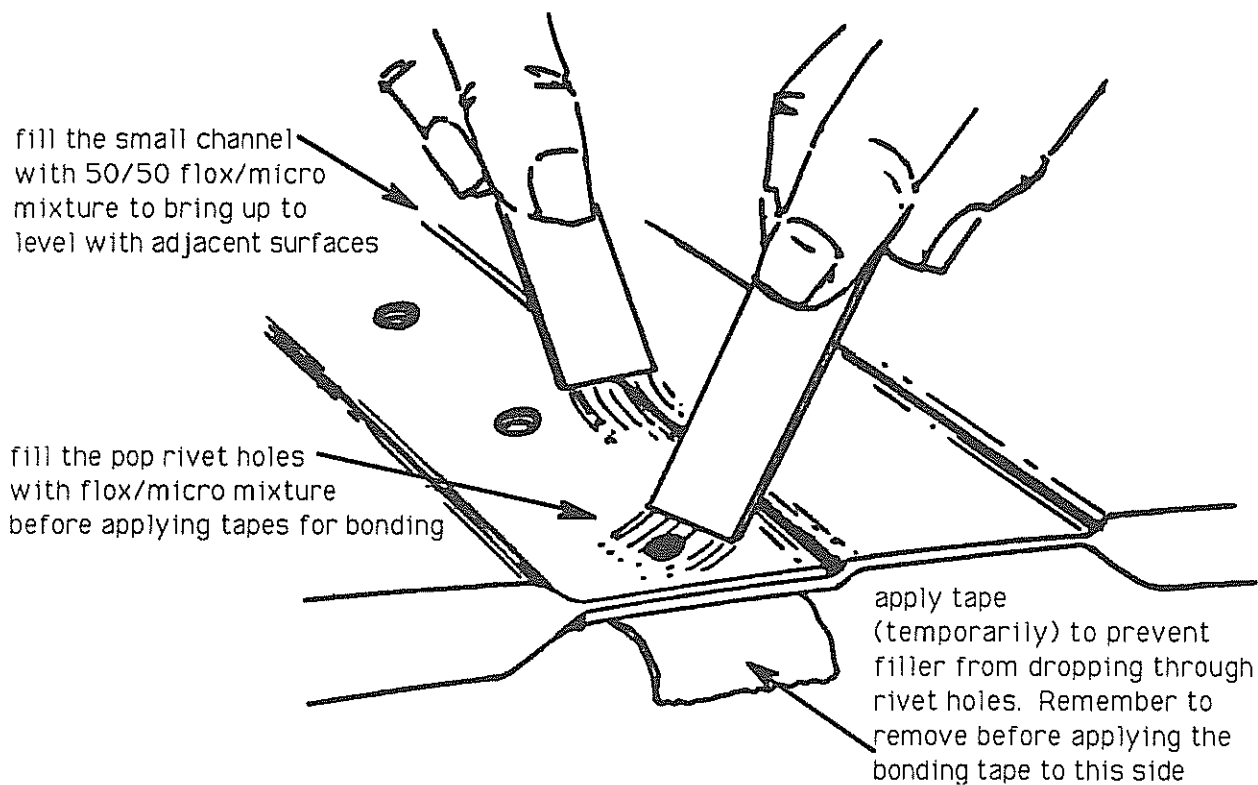

- f. After the adhesive has cured, the pop rivets are drilled out, the holes filled with a 50/50 mix of flox and micro (see Figure 1-11) and, without a need to wait for that to cure, a bid strip is being laid into place over the top of the joggles.

4.G.2. Procedure

- a. First make an estimate of the total length of "BID" tapes that will be required for the particular installation.
- b. Cut two pieces of plastic slightly larger than the BID tape is to be, and set them aside.

Preparing BID strips

Figure 1-12

If you have a lot of tapes to make, lay up a big panel and cut out multiple strips with either a 'pizza cutter', razor blade or scissors

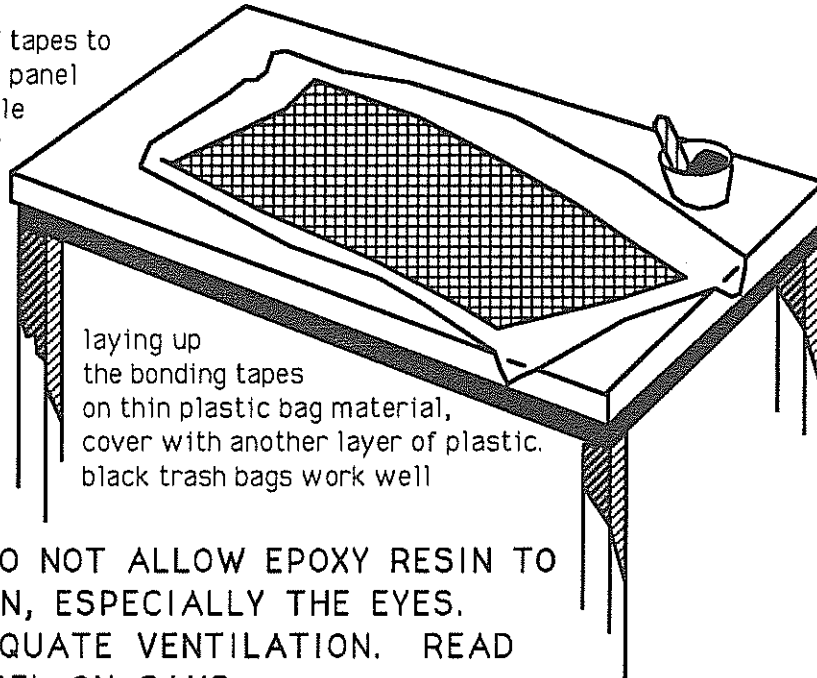

laying up the bonding tapes on thin plastic bag material, cover with another layer of plastic. black trash bags work well

WARNING - DO NOT ALLOW EPOXY RESIN TO CONTACT SKIN, ESPECIALLY THE EYES. PROVIDE ADEQUATE VENTILATION. READ WARNING LABEL ON CANS.

- c. Roll out and cut enough fiber glass cloth on a smooth cutting table to provide sufficient material for the above estimation. Cut the cloth "on the bias" as shown in figure 1-13, and leave just a little additional width since the cloth may tend to stretch and become more narrow when wetting out with resin. This phenomenon can easily be kept to a minimum, producing less waste. With most BID tapes being 2 ply, be sure to cut and stack the proper amount prior to applying resin.

Cutting fiberglass on a bias

Figure 1-13

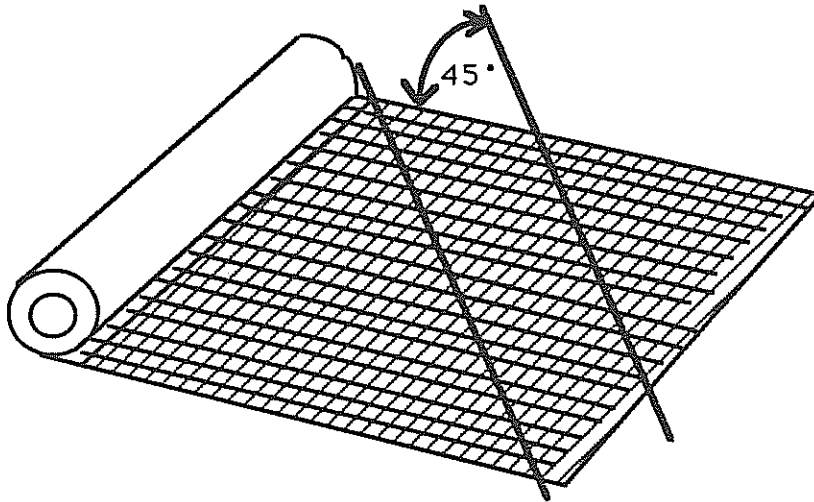

WARNING

NEVER USE A PIZZA (ROLLER BLADE) CUTTER OR BLADE TYPE CLOTH TRIMMER AGAINST THE FUSELAGE OR ANY OTHER PART. CURED GLASS FIBERS WILL BE DAMAGED BY THE CUTTING DISK OR BLADE.

- 4.G.2. d. As you cut the BID tape, stack it on one of the pieces of plastic cut in step b.
- e. Mix the resin thoroughly (usually about 2 minutes).
- f. Apply to the cloth using a squeegee to spread it around. Start in the middle and work towards the edges. The resin will work best when kept at approximately 80°F (a box around your pumper or resin cans with a 40W light bulb inside will maintain a nice warm system, but turn it off if you will not be using the resin within the next 24 hours or less, to prevent evaporation of the esters in the system).
- g. The cloth must be uniformly wetted out, producing a uniform color. If there is any excess resin, gently squeegee (on a 45 or with the strand directions) the resin to the edges and off the BID. Squeegee out all the air bubbles by gently working them to the edges and off. Save all excess resin.
- h. When properly squeegeed out, lay the second piece of plastic over the top, and rub it down onto the BID underneath.

- 4.G.2. i. Using a felt tip marker or equivalent, mark out on the plastic the parallel BID width lines (usually 2"), and cut with either the pizza type cutter or a good pair of scissors. Using the pizza cutter usually works best, but should be performed on a hard plastic sheet (hard nylon or equivalent). See Figure 1-14.

2 BID "Sandwich"

Figure 1-14

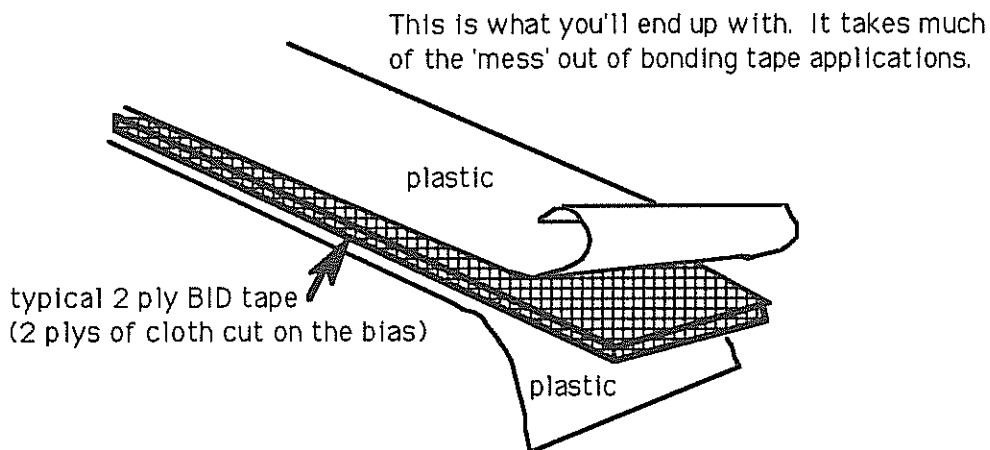

- j. Because the cloth is sandwiched between plastic layers (figure 1-14), the strip can now be picked up and handled without stretching the fiber glass and without getting a lot of resin on your hands. Brush a light coat of mixed epoxy resin on to the cleaned seam surface.

NOTE: There should NOT be any tendency of the resin to "fish eye" or bead up on the surface. If it does bead up, that will indicate contaminants on the surface which will require re-cleaning. It is often additionally helpful to actually "sand" this resin into the prepreg seam surface using 80 grit sandpaper. After applying the resin to wet out the seam area, lightly sand this area, working the resin down into the prepreg. This will require only a very few actual sanding strokes (2 or 3 maximum over any given area), do not over sand for this operation.

- k. Peel one side of the plastic away from the BID and lay the BID strip down onto the prepared seam.

WARNING! Be sure that you are laying the side *WITHOUT* the plastic down onto the seam. TO ERR HERE COULD BE DISASTROUS.

- 4.G.2. 1. Using a paper towel in your hand, firmly rub the BID down onto the seam area. The plastic should still be on the exterior surface of the BID.
- m. When the BID strip is firmly rubbed down, gently peel the top plastic piece off.
- n. Using a stipple brush with the bristles trimmed down per figure 1-15, gently work out any remaining air bubbles. These bubbles will have to be "walked" out by gently stippling on a 45° angle to the sides (or in a direction *WITH* the run of the threads in the cloth). Be gentle here since the BID tapes are quite easily pushed out of shape. If they do become pushed out of shape, gently stipple them back into proper shape and alignment within the joggle seam lines.

Stippling brush

Figure 1-15

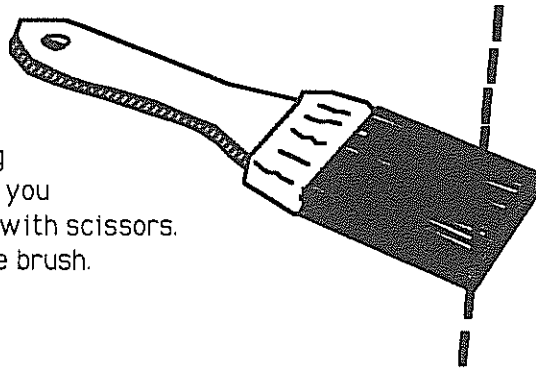

You'll find that the stippling brushes will work better if you first cut them down a little with scissors. Cut a slight angle across the brush.

- o. Any epoxy which is left over as waste should be saved and inspected in approx. 24 hours to verify that it was in fact properly prepared and has cured satisfactorily. Note that in cooler climates, 24 hours may not produce a fully hard surface. Within 48 hours, it should certainly be hard although a true full cure will take as long as five (5) days. After three hours or so, the tape should also be removed from the inside seam.

NOTE: TAPE ON ANY PART WILL LEAVE A RESIDUE THAT MUST BE CLEANED OFF ONCE THE TAPE IS REMOVED. THIS WILL PREVENT IT FROM BEING TRANSFERRED TO OTHER SURFACES BY HANDLING, AND PREVENT THE POSSIBILITY OF ANY BID TAPES BEING LAID OVER THE RESIDUE.

CHAPTER 2: MAIN (FWD) WING SPAR COMPLETION

REVISIONS

From time to time, revisions to this assembly manual may be deemed necessary. When such revisions are made, you should immediately replace all outdated pages with the revised pages. Discard the out dated pages. Note that on the lower right corner of each page is a "revision date". Initial printings will have the number "0" printed and the printing date. All subsequent revisions will have the revision number followed by the date of that revision. When such revisions are made, a "table of revisions" page will also be issued. This page (or pages) should be inserted in front of the opening page (this page) of each affected chapter. A new "table of revisions" page will accompany any revision made to a chapter.

Arrows

Most drawings will have arrows to show which direction the parts are facing, unless the drawing itself makes that very obvious. "A/C UP" refers to the direction that would be up if the part were installed in a plane sitting in the upright position. In most cases the part shown will be oriented in the same position as the part itself will be placed during that particular assembly step. However, time goes on and changes are made, so careful attention should be paid to the orientation arrows. That old cartoon of the guy agonizing over the plans for his canoe, built one end up, one end down, should not happen in real life. Especially to you.

CONTENTS

1. INTRODUCTION
2. DRAWING LIST
3. SPECIAL PARTS, TOOLS & SUPPLIES LIST
 - A. PARTS
 - B. TOOLS
 - C. MATERIALS & SUPPLIES
4. PROCEDURE
 - A. LOCATING INSERTS
 - B. MAIN GEAR PRIMARY & SECONDARY ATTACH POINTS
 - C. AILERON DISCONNECT IDLER ARM

LANCAIR® 320FB

2-1

Chapter 2

REV. 0 / 11-1-91

MAIN (FWD) WING SPAR COMPLETION

1. **INTRODUCTION**

The purpose of this chapter is to complete the installation of the center main spar assemblies and wing attach points. The steps we need to perform are:

1. Locating the aluminum inserts in the spars
2. Installation of secondary attachment bolts
3. Installation of aileron disconnect idler arm
4. Installation of primary landing gear attachment plate.



2-2

Chapter 2	REV.	0 / 11-1-91
MAIN (FWD) WING SPAR COMPLETION		

2. **DRAWING LIST**

- 2-1 Page 2-7 Spar insert locations
- 2-2 Page 2-8 Secondary screw locations in spar web/aluminum inserts
- 2-3 Page 2-8 Countersinking secondary screw holes
- 2-4 Page 2-9 Secondary screw locations on CTR main spar
- 2-5 Page 2-10 BL-48.25 Cross section
- 2-6 Page 2-11 BL-17.75 Cross section
- 2-7 Page 2-12 Main spar assembly
- 2-8 Page 2-15 Aluminum mounting plate
- 2-9 Page 2-16 Aileron idler arm installation
- 2-10 Page 2-18 Full size pattern for aileron idler arm
- 2-11 Page 2-19 Rivet finishing



2-3

Chapter 2

REV. 0 / 11-1-91

MAIN (FWD) WING SPAR COMPLETION



3. **SPECIAL PARTS, TOOLS & SUPPLIES LIST**

A. Parts

- Bottom Butterfly with Fwd & Aft Ctr Spars
- Aluminum mounting plates
- Aileron Idler Arm assemblies



2-4

Chapter 2	REV. 0 / 11-1-91
MAIN (FWD) WING SPAR COMPLETION	



B. Tools

- Pencil
- Adhesive measurement syringes or balance scale or Epoxy Dispensing Pump
- Small weigh scale (should be capable of measurements as fine as .1 oz)
- Rubber gloves or protective hand coating
- Watch or clock
- Drill motor
- Drill bits:
 - 1/4"
 - 3/8"
 - 1/2"
 - #12
 - #30
- Sanding block
- Measuring tape
- Spotlight (or similar bright light source)



C. Materials & Supplies

- Hysol 9339 Structural Adhesive (supplied in kit)
- Mixing sticks - tongue depressors (supplied in kit)
- Mixing dish or cup (supplied in kit)
- #36 & #80 grit abrasive paper
- Paper toweling or cloth pieces
- Wax and silicone remover (available at auto body or paint shop)
- Methylene Chloride (MC) cleaner
- Epoxy, flox, micro, BID glass cloth



4. **PROCEDURE**

A. **Locating Inserts**

The Lancair wing is composed of C-section spars. The main spars (fwd) carry most of the loads. The aft spars carry primarily twist and landing loads. There are six pre-molded spars installed; two in each wing (outbd main in front and outbd aft), and the center main and center aft. The three main and the center aft spars all have aluminum inserts bonded within their shear webs at strategic locations depending on the particular spar (see the darkened areas on Figure 2-1).

IT IS ABSOLUTELY MANDATORY THAT THE ACTUAL POSITIONS OF THE INSERTS CIRCLED BE VERIFIED ON YOUR OWN PARTICULAR SPARS.

1. This can easily be achieved by placing a spot light on one side of the web and position it to shine through the web. In a dimly lit room, it is very easy to see where the aluminum actually is positioned. **CLEARLY MARK THE POSITION OF EACH ON THE SURFACE OF THE SPARS FOR FUTURE REFERENCE. WHEN DRILLING FOR THE BOLTS, BE ABSOLUTELY SURE THAT YOU ARE DRILLING SOLIDLY THROUGH THE ALUMINUM INSERTS AND WILL MAINTAIN AT LEAST 3/8" CLEARANCE FROM THE EDGES OF THE ALUMINUM INSERTS. 1/4" SIDE CLEARANCE IS SUFFICIENT FOR THE CTR AFT SPAR (1/4") ATTACH BOLTS.**

Spar Insert Locations

Figure 2-1

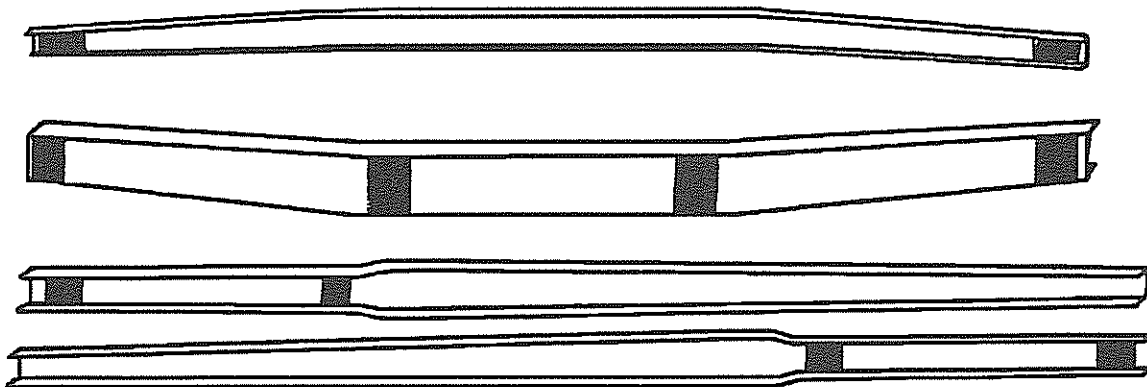

2. Referring to figure 2-2, you need to determine locations for two 1/4" flat-head machine screws in the area of the BL-48.25 attach bushing at each end of the Ctr Main Spar. The purpose of these machine screws is to help spread the load from the aluminum web inserts into the E glass web itself.

The exact location of the screws are not critical, and they do not need to align with the 1/4" bolts on the fwd spar web even though figure 2-4 shows them as being in relative alignment. *What is most important is that you solidly enter through the aluminum inserts. BE SURE that you have at least 1/4" of aluminum around all of the screw locations.* The area above the insert can be used, but you are going to have an aileron rod going through there, and there might be interference between the two.

Secondary Screw Locations in Spar Web/Aluminum Insert

Figure 2-2

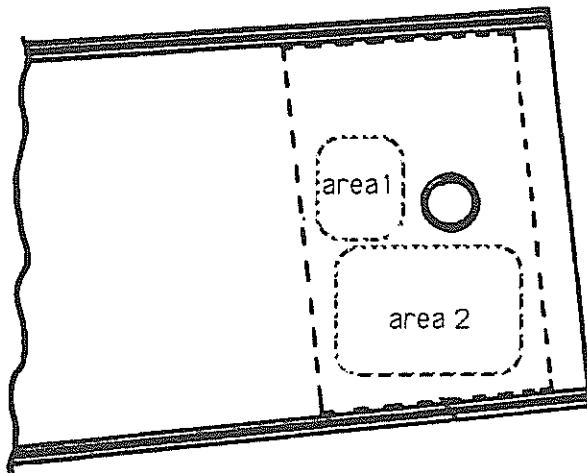

BE SURE TO LEAVE AT LEAST 1/4" OF ALUMINUM AROUND ALL HOLES, AND DRILL AS STRAIGHT AS POSSIBLE THROUGH THE BEAM.

3. Drill the holes in the locations you have selected, drilling as straight and perpendicular to the surface as possible. **DO NOT USE ANY OIL OR LUBE WHEN DRILLING THESE HOLES.**

Countersinking Secondary Screw Holes

Figure 2-3

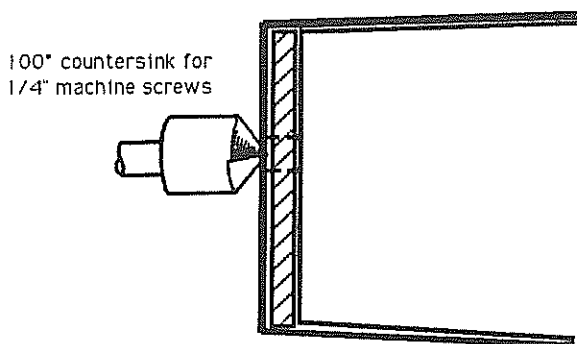

4. Referring to figure 2-3, countersink the holes in the fwd face of the spar to accept the flat head 1/4" machine screws. The proper countersink is 100°.

5. Purchase or make from scrap aluminum two small fab washers as shown in figure 2-4. Insert the 1/4" machine screws (MS24694-S103) through the front of the spar, and place one of the washers under a screw at each end of the spar. This will serve as a safety wire position for the main 1/2" attach bolt at those locations. Tighten in place using 1/4-28 locking nuts (AN364 or AN365-428).

Secondary Screw Locations on CTR Main Spar

Figure 2-4

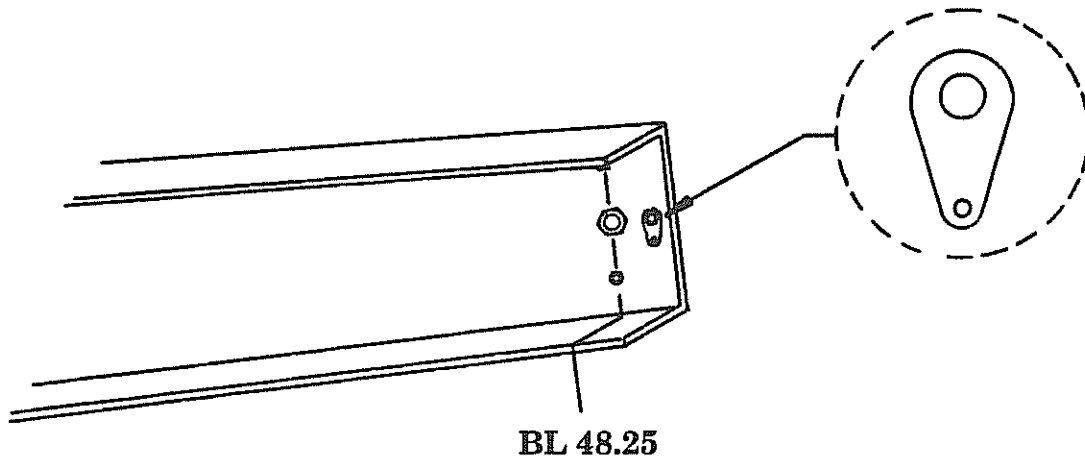

6. Figure 2-5 shows the connection of the outboard main spar to the center main spar at the BL-48.25 area and figure 2-6 shows the connection of the spars at the BL-17.75 area, with all of the appropriate hardware.

BL-48.25 CROSS SECTION

Figure 2-5

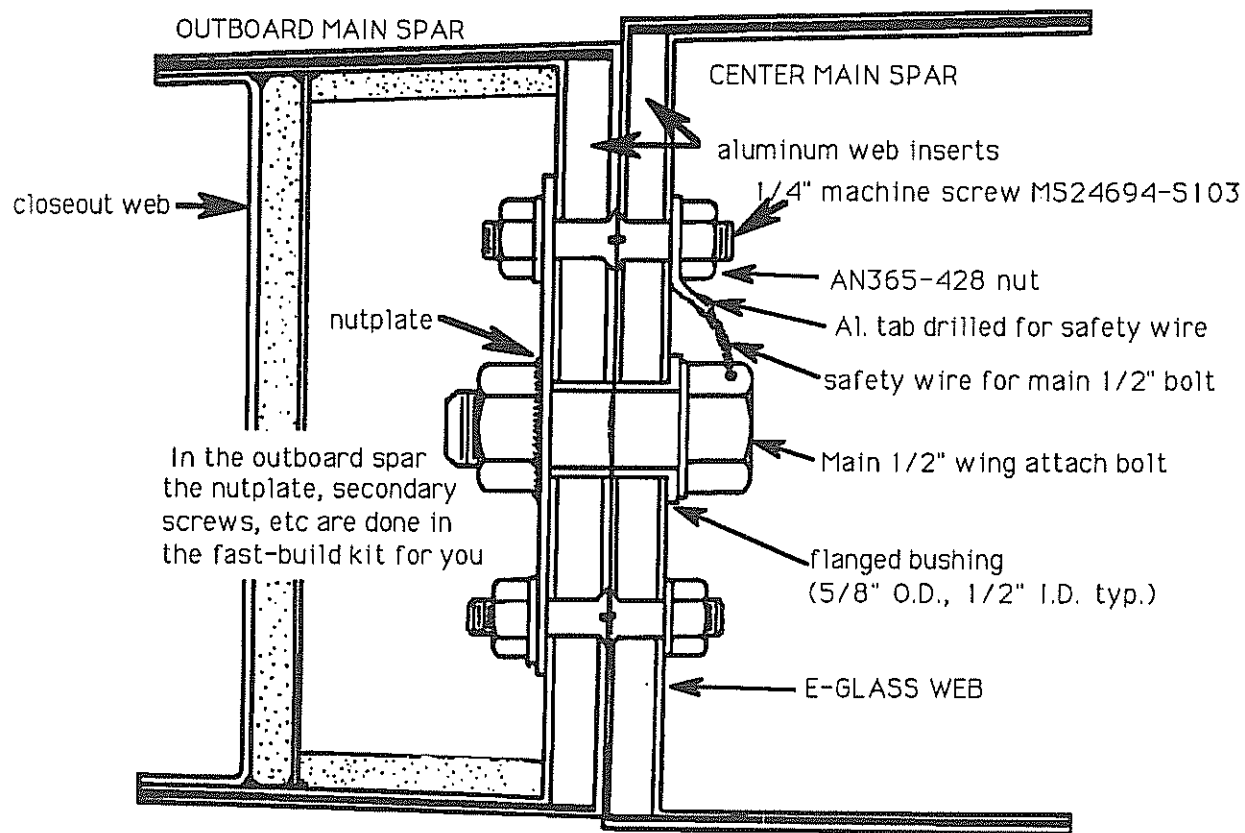

AN8H-10

BL-17.75 CROSS SECTION

Figure 2-6

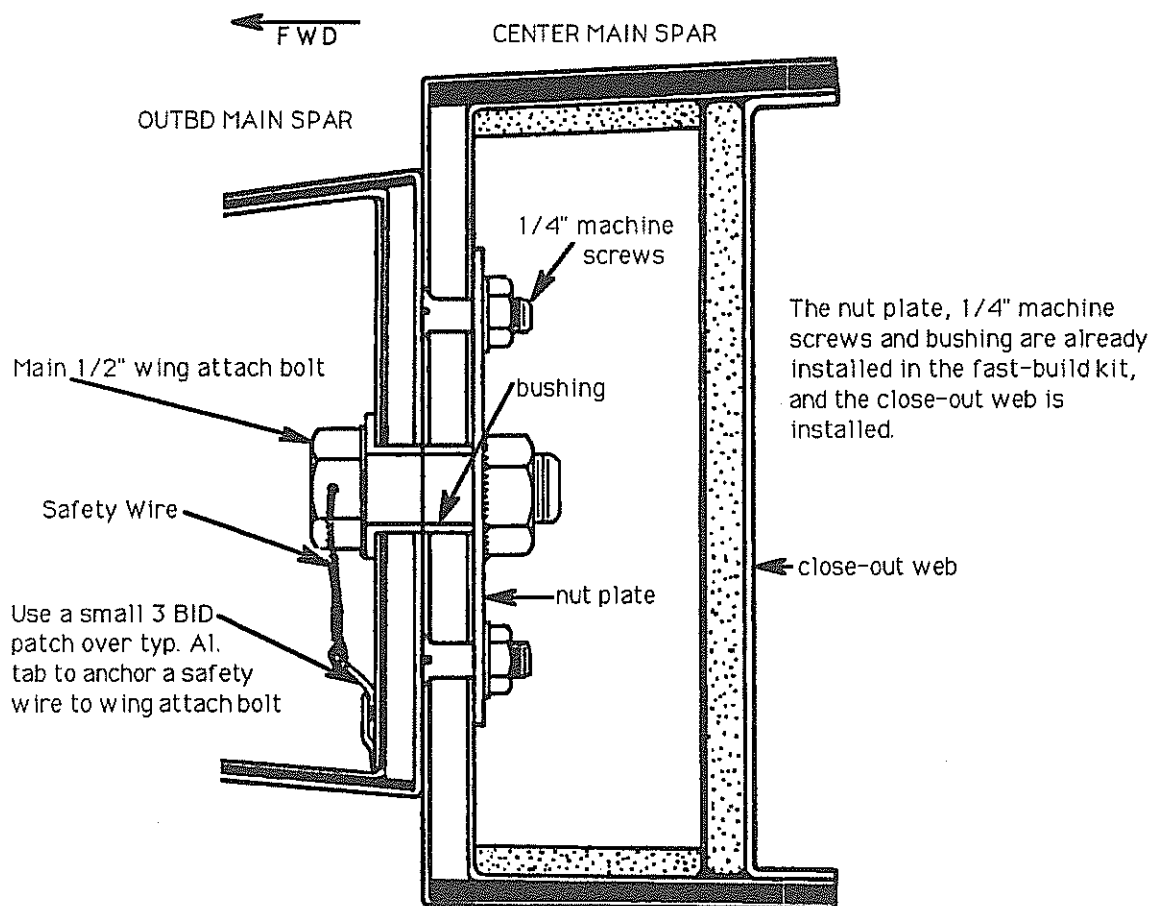

7. Use a 3 BID layup to attach the aluminum tabs to the outboard main spar in the location shown. This will be used as an anchor to safety wire the 1/2" main wing attach bolt.
8. Referring to figure 2-7, drill a 1/2" hole in each of the side braces for the fuel line, if you want the line to run through the front part of the wing. Some builders prefer to route the fuel lines through the trailing edge portion of the wing, and if you choose this route, then don't bother to drill these two holes.

MAIN SPAR ASSEMBLY

Figure 2-7

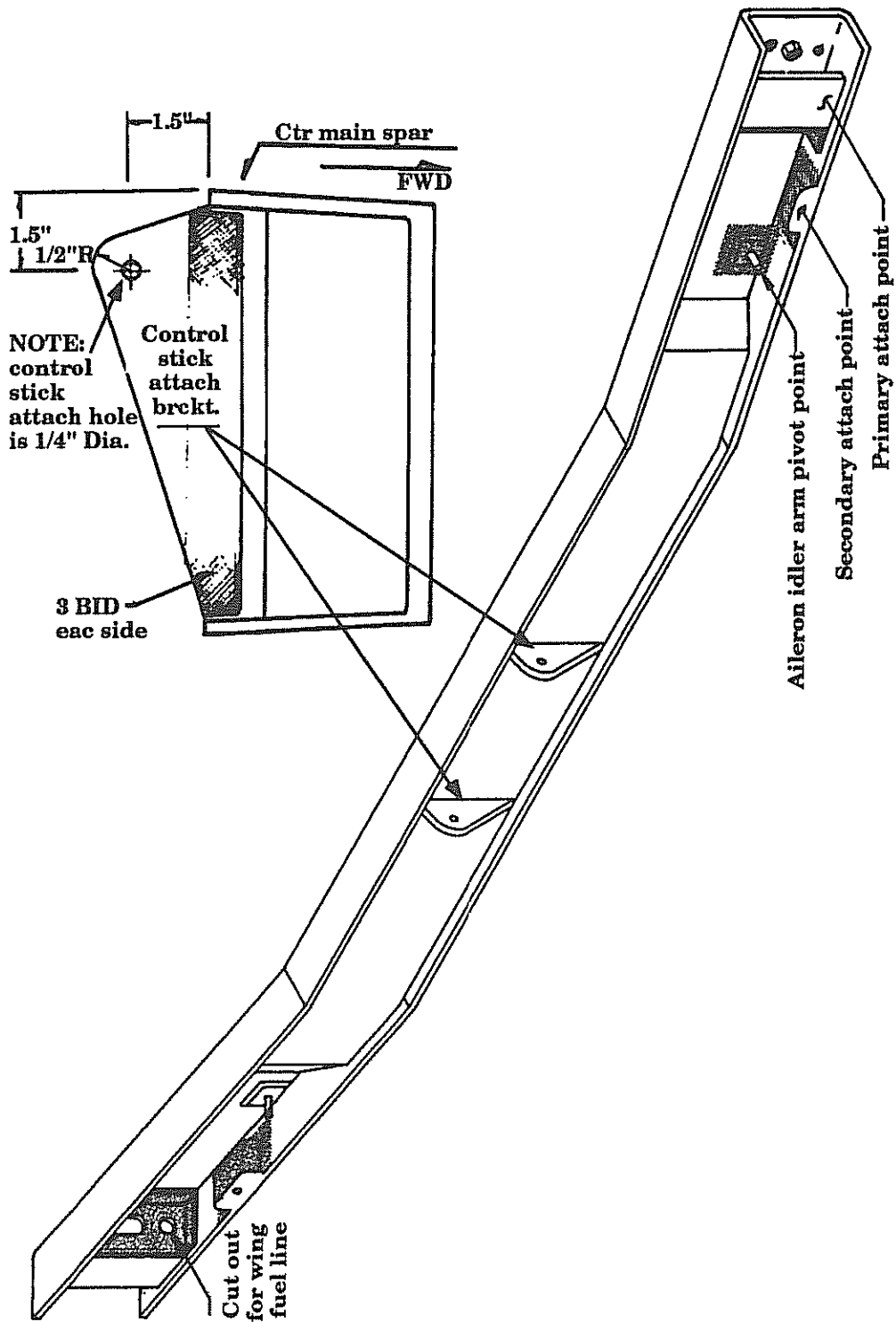

9. Using the dimensions given in the inset of figure 2-7, drill the 1/4" hole for the control stick attach point in each of the control stick attach brackets on the main spar.

NOTE: It is not necessary, but perhaps a little easier, to install as much as possible into the ctr main spar before installing the belly pan/spar assembly into the fslg. To install the Main Gear Mounting Plates (GM4) and the aileron idler arm assembly at this time, proceed with the following instructions.



B. MAIN GEAR PRIMARY & SECONDARY ATTACH POINTS

Main Landing Gear Primary Attach Points - The main landing gear will attach to both the ctr fwd and ctr aft spars with their aluminum attach plates. The ctr main spar has receiving "hard points" (GM12) installed to accept the aluminum mounting plates (GM4). Refer to figure 2-7.

Main Landing Gear Secondary Attach Points - these are simply phenolic blocks glassed into position where the over center links pivot (figure 2-7). The over center pivot bolt will attach through this secondary point.

1. Select the GM4 main gear alignment brackets. These machined aluminum parts will establish the proper alignment of the main gear pivot point with the over-center link pivot point. They will be mounted to the GM12 phenolic which has been bonded into the center main spar.
2. Position the GM4 bracket per figure 2-8. The lower edge of this bracket at the wide end will rest on the lower spar cap, but the narrow end which has the short standoff welded onto it will **NOT** rest on the bottom spar cap. This end must be raised off the bottom spar cap in order to allow for adequate clearance of the 3/8" bolt and nut which will mount at this location (if the GM4 bracket were mounted flat to the bottom spar cap, the nut of the 3/8" bolt which mounts the over-center links would not have sufficient clearance on the fwd side of the secondary phenolic attach point). The GM4 bracket should be lined up at the large end with BL 47.5, then raised *at the narrow end, about 5/16"*, so that you have a gap between the lower spar cap and the bracket, at the point below the standoff, of 1/4".

NOTE: The welded standoff with the 3/8" hole in it protrudes *AFT*.

3. When the fit looks correct, use a 1/4" drill bit and drill through for the four 1/4" mounting bolts at the primary attach point. These four bolts may be permanently set at this time. They should be set with the nuts on the *AFT* side to afford more clearance between the ctr main spar web and the GM12 primary attach point (the aileron push rod will pass through there and the bolt head will require less space than the nut and washer end).
4. Drill through for the 3/8" bolt at the secondary attach point. This obviously requires a 3/8" drill bit. Be careful not to rock the drill bit back and forth while drilling since that would elongate the hole in the GM4 alignment bracket.

ALUMINUM MOUNTING PLATE

Figure 2-8

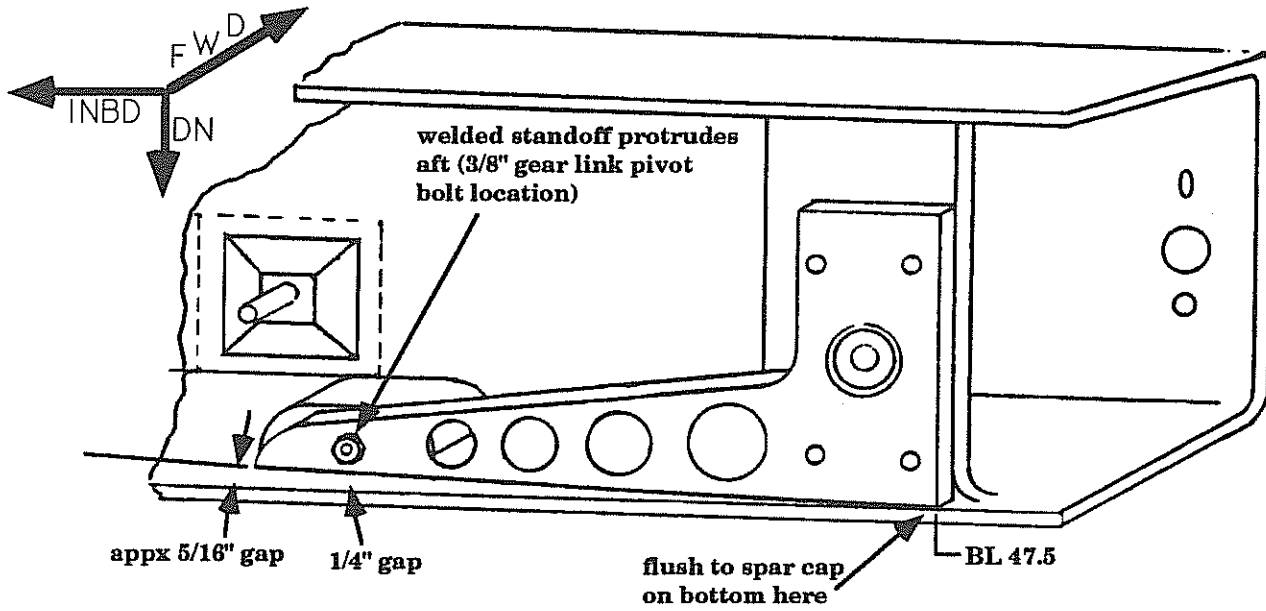

C. Aileron Disconnect Idler Arm

Referring to figure 2-7, you will see an aileron idler arm pivot point. This is a pivot location for the aileron idler arm. It serves as a disconnect point when removing the outboard wings. It is already installed in the proper location, with an AN4-13A 1/4" bolt glassed in position so that, when mounted, the idler arm can be as close to the spar web as possible and still provide adequate clearance for the outbd aileron push rod with nut and washer.

You may, at this time, build and install the idler arms. There are two assemblies required, one per side. We have provided the flat plate stock with the center bellcrank bearing holes (0.755" dia.) already drilled. The same stock material (with 0.755" holes punched) will also be used to make the outbd aileron bellcranks and the elevator idler arms.

Aileron idler arm installation

Figure 2-9

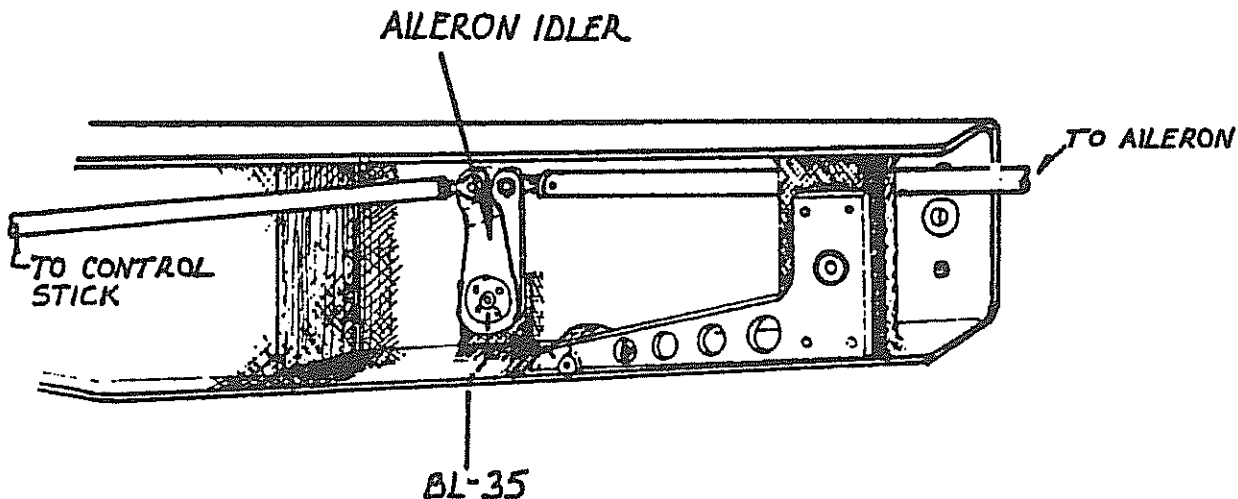

1. Using the pattern shown in figure 2-11, cut the idler arms out with either a band saw or sabre saw with metal cutting blades.

Note: There are 4 pieces which, except for the bends, have the same contour. The two pieces without bends can be made directly off the drawing dimensions of figure 2-11. The two pieces which DO have bends will obviously net out a slightly smaller dimension than the 2-3/4" dimension shown. This is OK as long as the left side matches the right side. This will provide a very slight increase in aileron displacement relative to stick travel.

Also note that a second push rod (AL3) pick up hole is shown 7/16" below the top hole. This is generally preferred as it will lighten the aileron stick forces somewhat and still provide a crisp roll rate.

WARNING: Do not simply place the 0.090" aluminum in a vise and bend it over. This would result in too sharp of a radius and a resultant crack which would then result in failure of the aileron controls.

THE MINIMUM RADIUS FOR THESE BENDS IS 1/2". BEND THE ALUMINUM OVER A SUITABLE MANDREL, SUCH AS A PIECE OF 1" PIPE OR SIMILAR. BE SURE THAT THERE ARE NO SCRATCHES OR NICKS. FILE, SAND AND POLISH IF REQUIRED.



LANCAIR® 320FB

2-17

Chapter 2

REV. 0 / 11-1-91

MAIN (FWD) WING SPAR COMPLETION



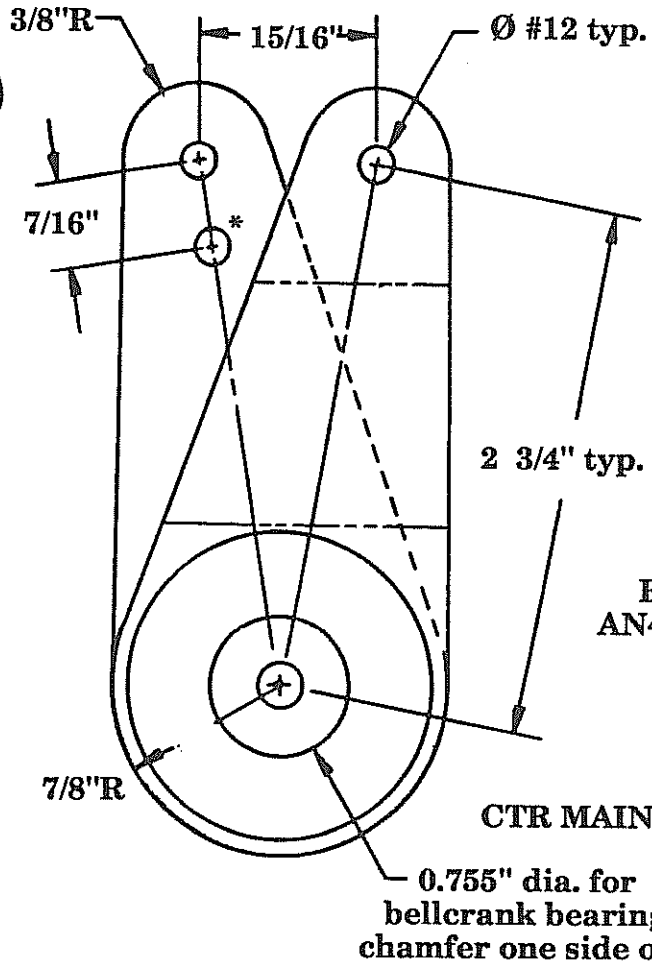

***NOTE:** Using this hole for aileron connection will produce a lighter "feel" and is generally preferred.

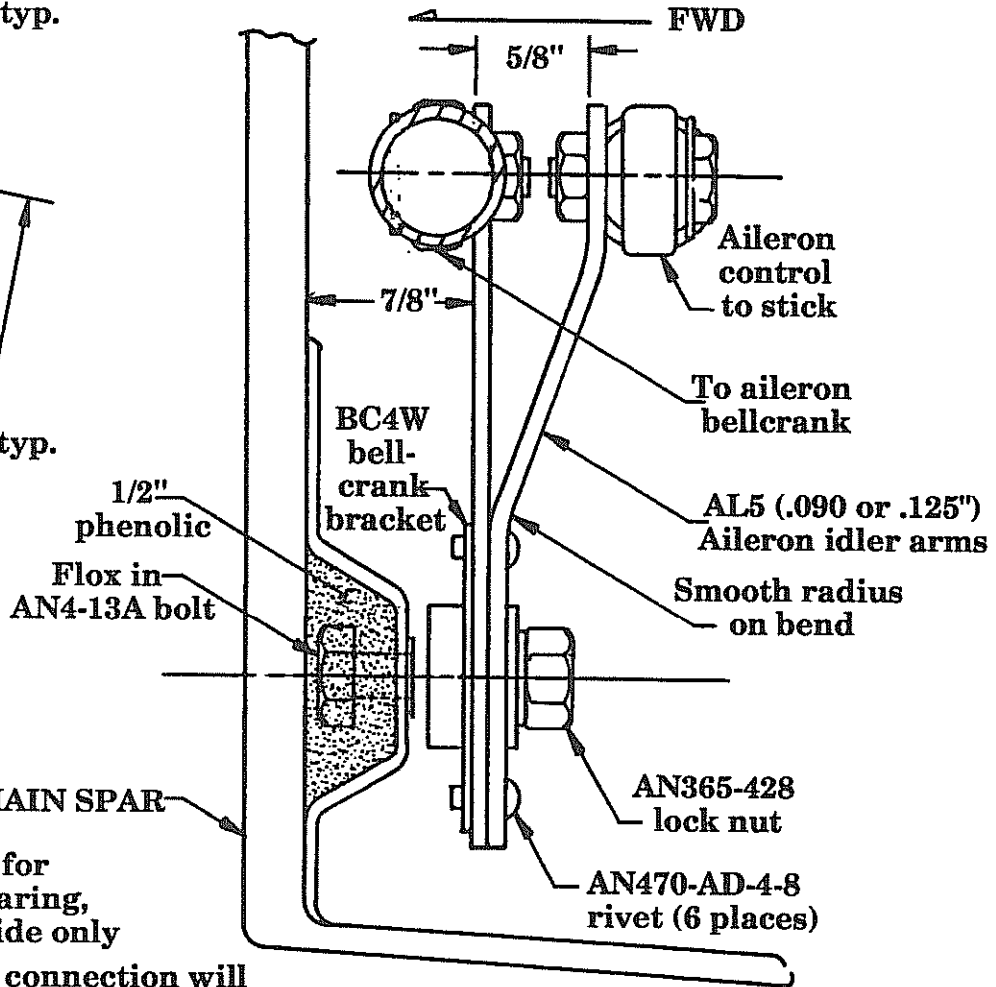

Full-size pattern for aileron idler arm
Figure 2-10

2. With the pieces cut, file all edges smooth and sand (220-320 grit) any file marks out.
3. Drill the two #12 holes per figure 2-10.
4. Position the BC4W10 bellcrank bearings on the idler arms using the 0.755" hole as a centering hole for the bearing. You may need to slightly radius the hole to accept the idler arm. The bearing should lay flat against the first idler arm.
5. Clamp the assembly together firmly (**but remember, no nicks**) and, using the bellcrank bearing flange as a drill guide, drill the 1/8" (#30 bit) rivet holes through every other hole in the flange, giving you 6 locations. You'll find it best to drill just one hole first, then set the rivet before drilling the next hole. This method will cause the bellcrank to stay in good alignment with the drilled holes.
6. Install the AN470AD-4-8 round head rivets. See figure 2-11 for proper look of the finished rivet. The rivets are easiest installed using a rivet squeezer. A rivet set with a hammer will also work satisfactorily. The AN470AD-4-20 rivets can be cut down to size.

RIVET FINISHING

Figure 2-11

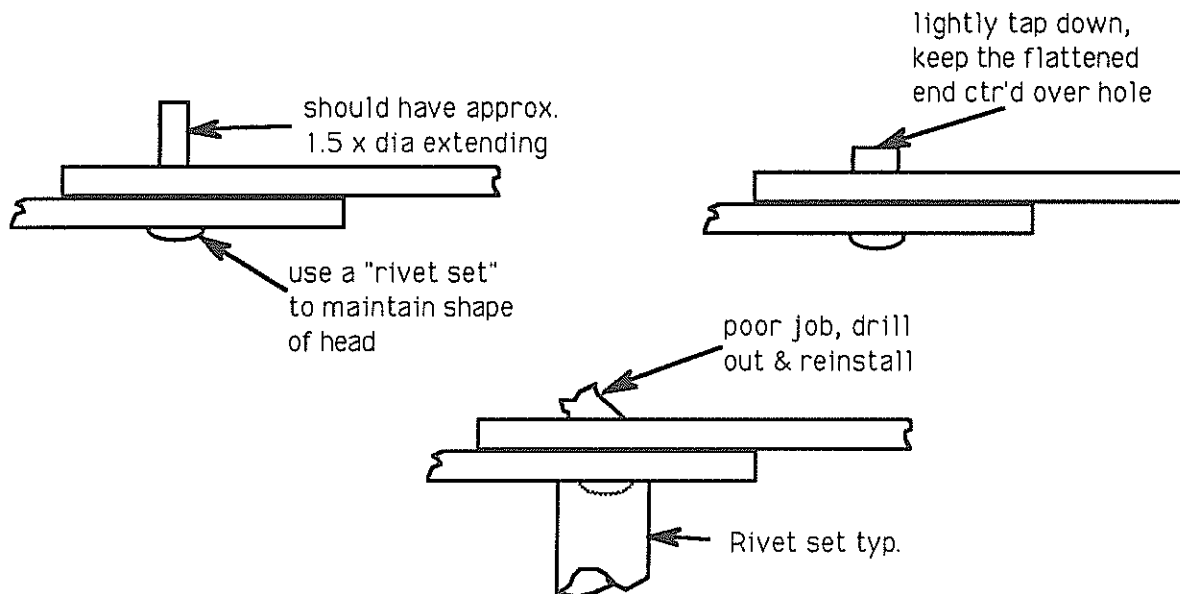

The main spar/belly pan assembly is now as complete as necessary for installation into the fuselage, which is covered in the next chapter.

NOTE: It is entirely possible to perform several assembly area installations virtually at the same time, or in a different sequence from that shown here. However, it is recommended that you review the entire manual before doing so, to prevent the possibility of closing off an area before everything is in it, etc.

CHAPTER 3: FUSELAGE/MAIN SPAR ASSEMBLY PROCEDURE

REVISIONS

From time to time, revisions to this assembly manual may be deemed necessary. When such revisions are made, you should immediately replace all outdated pages with the revised pages. Discard the out dated pages. Note that on the lower right corner of each page is a "revision date". Initial printings will have the number "0" printed and the printing date. All subsequent revisions will have the revision number followed by the date of that revision. When such revisions are made, a "table of revisions" page will also be issued. This page (or pages) should be inserted in front of the opening page (this page) of each affected chapter. A new "table of revisions" page will accompany any revision made to a chapter.

Arrows

Most drawings will have arrows to show which direction the parts are facing, unless the drawing itself makes that very obvious. "A/C UP" refers to the direction that would be up if the part were installed in a plane sitting in the upright position. In most cases the part shown will be oriented in the same position as the part itself will be placed during that particular assembly step. However, time goes on and changes are made, so careful attention should be paid to the orientation arrows. That old cartoon of the guy agonizing over the plans for his canoe, built one end up, one end down, should not happen in real life. Especially to you.

CONTENTS

1. INTRODUCTION
2. DRAWING LIST
3. SPECIAL PARTS, TOOLS & SUPPLIES LIST
 - A. PARTS
 - B. TOOLS
 - C. MATERIALS & SUPPLIES
4. PROCEDURE
 - A. INSTALLING THE MAIN SPAR/BELLY PAN ASSY ONTO THE FUSELAGE



1. INTRODUCTION

The purpose of this chapter is to install the Main Spar/Belly Pan assembly onto the fuselage. The things that have to be achieved are:

1. The squareness of the wings to the fuselage
2. The angle of incidence
3. The aesthetics of the wing to fuselage junction



3-2

Chapter 3	REV.	0 / 11-1-91
FUSELAGE/MAIN SPAR ASSEMBLY		



2. **DRAWING LIST**

- 3-1 Page 3-9 Tail level reference
- 3-2 Page 3-9 Inverted fuselage
- 3-3 Page 3-10 String line, aft end
- 3-4 Page 3-11 String line, fslg bottom
- 3-5 Page 3-12 Main Spar Center Location
- 3-6 Page 3-13 Squaring spar assembly to fslg
- 3-7 Page 3-13 Attaching Rear Spar Supports to FSLG
- 3-8 Page 3-18 Wing/Belly Pan Alignment
- 3-9 Page 3-19 Belly Pan Installation



Lancair International Inc. Copyright © 1991, Redmond, OR 97756

3-3

Chapter 3

REV. 0 / 11-1-91

FUSELAGE/MAIN SPAR ASSEMBLY



3. EQUIPMENT REQUIRED

A. Parts

- Main spar/belly pan assembly
- Fuselage assembly
- Outboard wing panels



Lancair International Inc. Copyright © 1991, Redmond, OR 97756

3-4

Chapter 3

REV. 0 / 11-1-91

FUSELAGE/MAIN SPAR ASSEMBLY



B. Tools

- Sheet Metal Shears
- Carpenter's Square
- Carpenter's level - 4 ft. minimum
- Pencil
- Utility knife or equivalent
- Saw Horses (2)
- Adhesive measurement syringes or balance scale or Epoxy Dispensing Pump
- Small weigh scale (should be capable of measurements as fine as .1 oz.)
- #6 x 3/8 sheet metal screws or
- 1/8" dia, about 1/4" material capacity clecoes and cleco pliers
- Rubber gloves or protective hand coating
- Watch or clock
- 1/8" dia drill bit
- Drill motor
- Pop rivet gun
- Sanding block
- Water level at least 15 ft. long
- 15 ft. measuring tape
- 4 C-clamps
- Sandbags or equiv., about 30 lbs.
- String line



C. Materials & supplies

- Hysol 9339 Structural Adhesive (supplied in kit)
- Mixing sticks - tongue depressors (supplied in kit)
- Mixing dish or cup (supplied in kit)
- #40 & #80 grit abrasive paper
- Paper toweling or cloth pieces
- Wax and silicone remover (available at auto body or paint shop)
- Methylene Chloride (MC) cleaner
- Soft aluminum pop rivets, 1/8" dia., 3/8" grip
- 1" high density foam
- epoxy, flox, micro, BID glass cloth



3-6

Chapter 3

REV.

0 / 11-1-91

FUSELAGE/MAIN SPAR ASSEMBLY



4. **PROCEDURE**

A. **Installing the Main Spar/Belly Pan assembly onto the fuselage.**

PRIORITIES:

It is difficult to make any two parts **exactly** the same. Because of this, you can expect to find small variances between dimensions of small parts, and the variances will increase proportionally with the size of the part. The goals you need to achieve, and their order of importance in the event of having to make a trade-off, are:

1. **THE LEFT WING SHOULD BE LIKE THE RIGHT WING** (Or, if you choose, vice versa).
2. The trailing edge should be straight from root to tip.
3. The gap between the spars and the belly pan should not be less than the thickness of the wing skin that will mount there.
4. The fuselage should be level.

Let's examine this list for a moment, and understand why and what we can do about keeping these priorities in order:

#1, the wings should be alike. The wings fly, the rest is along for the ride. The wings need to be as symmetrical to each other as possible. If they are not very close to identical, your handling will suffer. A little bit of trim adjustment will correct for most minor irregularities, but for 'wings level' flight, the wings should be levelled to earth gravity and each other, not to the fuselage joggles.

#2, the trailing edge must be straight. The hinges for the flaps and ailerons will be mounted back there, and if they aren't straight, things will bind and wear and again give you the problems associated with asymmetry.

#3, the gap at the wing root should be proper. If, to get #1 & #2 priorities right, the gap is too little or too much, a bit of cutting or bending, or micro filling will correct it. However, if the gap is too little, then adding a bit of material to all of the foam positioning blocks or, if the gap is just at one corner or end, a slight flex of the fillet joggle.

#4, Keeping the fuselage level is the lowest priority, simply because a degree one way or the other will have little or no effect on flying the plane, and will not be noticeable to the pilot or passenger. If canting the fuselage appears to be the only way to correct a gap between the wing root and the fuselage, take heart. Depending on the spot you want to correct, you may be able to adjust the fuselage fillet up or down slightly by heating it with a heat gun and applying uniform pressure (being very careful not to overdo it) to get it where you want it. Give it a try first, but if making the fuselage a little unlevel is the best solution, don't worry about it. It will not cause any problem later if you shift it slightly now.

Because of the rigidity of the fuselage structure (fslg), the rigidity of the Main Spar/Belly Pan structure (Spar assembly) and the construction method used of mating the two during their initial manufacture, these points are really quite easy to achieve.

We will begin by taking several measurements, some to just double check that nothing has taken a wrong set during shipment or storage, and other measurements that we will use later when bonding the parts together. Then we will put the spar assembly into the fslg, and do some initial 'squaring'. Next we'll install the wings and take some final measurements. After all the necessary adjustments have been made, the final step will be to position the spar assembly and hold it in place for the time required for the bonding adhesive to make it a permanent part of the fslg. Most of the drawings you will need are included here, but you may need the BL-50 Rib drawing from your blueprint package if the level lines are not visible on the ribs.

NOTE: Great care is taken when constructing the parts for the fast-build kit, and as a result, it typically goes together with very little 'tweaking' necessary. If you come across a measurement or part that seems 'out-of-whack', recheck your set-up before cutting anything away that might really be correct and that you might need later.

1. The first thing we need to do is make a couple of reference marks on the tail of the plane that will be used later to level it in the upside down position. Grab your carpenter's square, and go to the tail of the plane. Referring to Figure 3-1, place the square on the inside of the plane, against the bottom, and measure up five (5") inches, marking that spot on the outside of the tail. You only need to mark one side. Also, make a mark on both longerons directly above the high density foam pads. You'll use these marks to level the fslg later, upside down, so draw a line across the longerons that you can see from both sides & underneath (a couple of pieces of 1" tape would work as well or better, see figure 3-2).

TAIL LEVEL REFERENCE

Figure 3-1

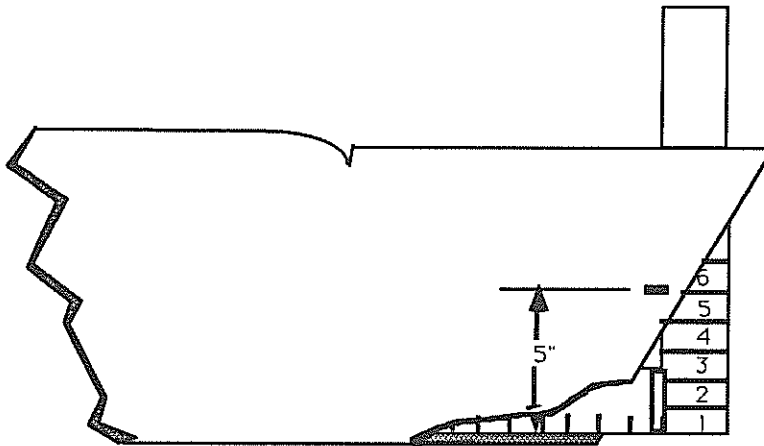

2. The next thing we need to do is get the fuselage into a position where it can be leveled, off of the floor, accessible from all sides, and upside down. The best thing is saw horses, which can be quickly constructed from some old 2x4's. You will need 2 of them for proper support. You could use a steady table, but the saw horses are a lot easier to work around, and they let you get under the fuselage for a couple of the measurements you'll need.

NOTE: *There are high density foam pads attached to the fuselage. Be careful not to damage or distort them.*

3. Turn the fslg upside down and rest it on a steady table or horses as shown in Figure 3-2. Be careful not to dent the longerons, they will be used from time to time for reference.

INVERTED FUSELAGE

Figure 3-2

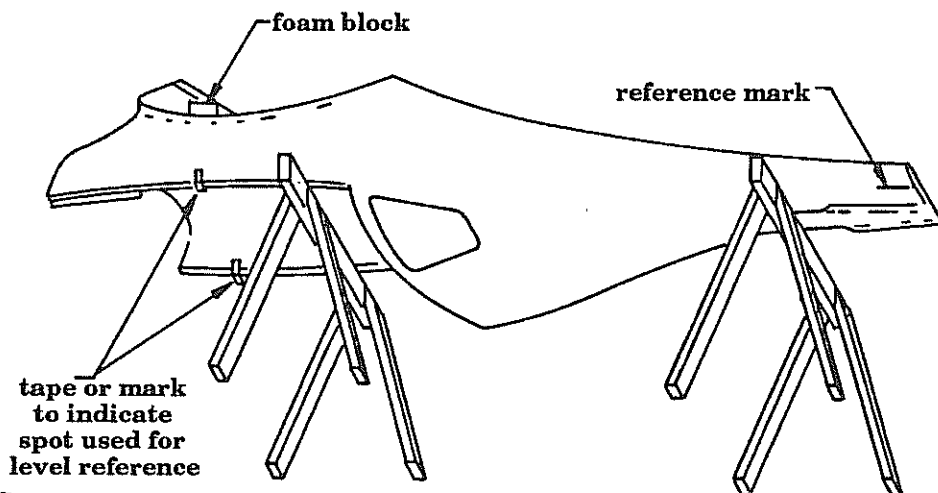

4. Laying a level across the longerons from side to side, underneath, at the spot you marked with tape, level the fslg by placing shims between the longerons and the front horse.
5. Once the plane is level side to side, you need to establish a fwd-to-aft level line. Houdini could probably do this next step with mirrors, but you may want to call a friend to help. On the front of the firewall where the two lines cross there is a small hole. Using a water level, place one end of the water line at this point. Take the other end of the water level back to the mark you made 5" up the side of the tail. Shimming between the rear horse and the tail, adjust so that the mark on the tail is level with the hole in the firewall. Recheck the side-to-side level, and re-adjust as necessary.

When you are level both ways, weight the fuselage down with something (we use shot bags, but if you don't happen to be a reloader, most anything will do) so that it will hold it's position through the next steps.

6. Examine the bottom (now on top) of the tail of the fuselage. There should be a 1/16" hole there, about 1/2" from the aft end, and at the bottom-most portion of the tail. Run a piece of string into the hole and tie it off to a pencil or something to hold it there, and run the other end of the string down the belly of the plane till it is past the firewall.

STRING LINE, AFT END

Figure 3-3

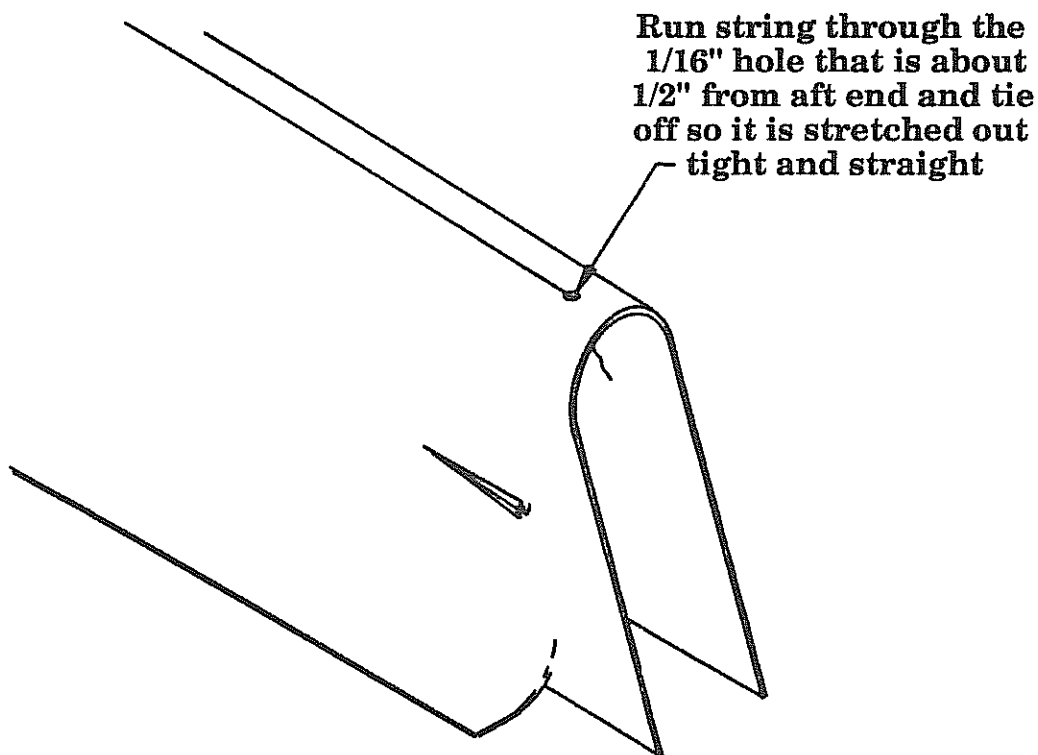

7. Lightly clamp a straight edge to the firewall, so that you have a point to tie the string to that is straight up from the hole we used earlier to level the plane. Use a level against the straight edge to establish true vertical. What we next want to achieve here is a straight line, drawn on the bottom of the plane, that runs from the firewall to the tail.

STRING LINE, FSLG BOTTOM

Figure 3-4

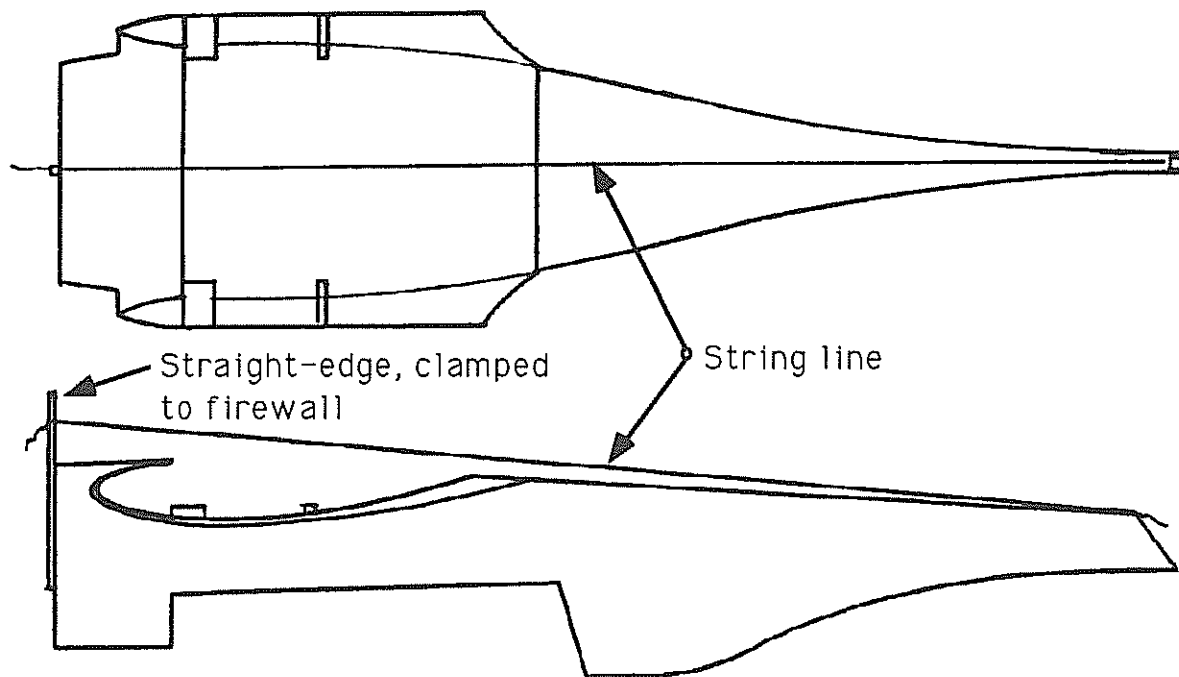

8. Using a plumb bob from the string line, mark several places on the fslg along the centerline. Then, using a straight edge, 'connect-the-dots' so that you have your centerline marked from end to end. Remove the string and straight edge.

This center line will be used for squaring and cutting of the wing fillets where the flaps butt up against them, and to get the Main Spar centered and in the exact proper position.

9. This is probably the best time to go ahead and measure out from the center line to the wing fillets, where the flaps will butt up against them, and determine which is the 'shorter' of the two (at the point of the foam blocks, it should be about 23" from centerline to edge of fillet, and about 23 1/4" at the flap point, refer to figure 3-4). Trim the longer side down to match. They don't have to be exact, but should be within 1/4" or so of each other after trimming.

10. Determine the center of the Main Spar:

Measure the main spar, as shown below, from forward corner to forward corner. Divide this dimension by two, and place a mark at that point, the center of the spar width. Using a square, make a line from the leading edge of the belly pan, at your center mark, back about 3 or 4 inches. We will use this line later to help center the belly pan assembly in the fuselage.

MAIN SPAR CENTER LOCATION MEASUREMENT

Figure 3-5

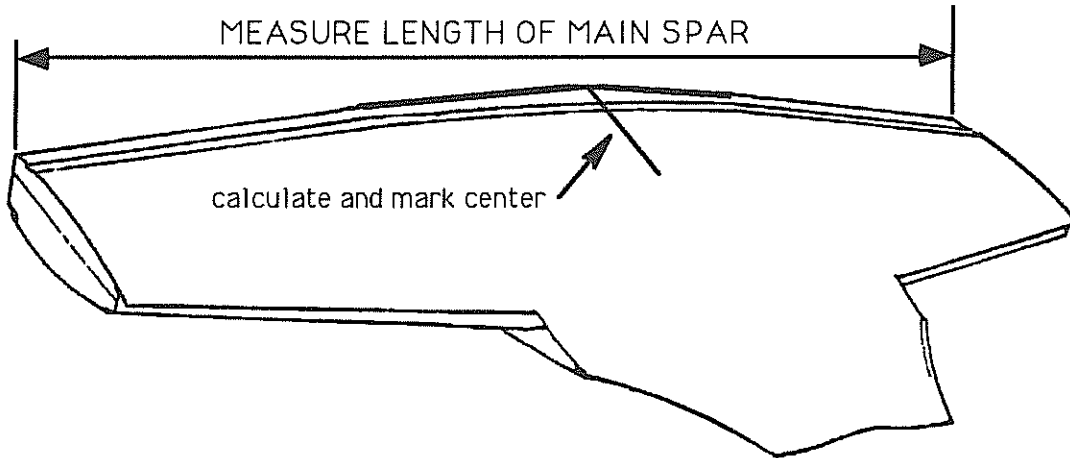

11. **Being careful not to disturb the level of the plane**, and referring to drawing 3-6 below, position the belly pan assembly so that the center mark of the belly pan is in line with the center mark of the plane bottom, and then position the belly pan assembly so that it is 27.5" from the **back** of the firewall to the **front** edge of the Main Spar. You can measure from inside the fslg, down both sides of the nose wheel tunnel, which should get you close enough for the next steps.
12. At this point, the rear spar is laying on the fslg. Mark where it is sitting on both sides of the fslg, and remove the spar assembly from the fslg.
13. Make a pair of high density foam blocks, similar to the ones on the fslg now, to support the rear spar. Make them up so that they will hold the rear spar about 5/8" off of the fslg. You will sand them down later to level the main spar assembly (the blocks usually end up to be holding the aft spar about 7/16" off of the fslg). Use micro to install them. Refer to figure 3-7.
14. After the pads have set up, carefully place the spar assembly back into position, 27.5" behind the firewall.

15. To get the spar assembly square with the fslg, refer again to the drawing below. We've found using a tape measure with a hole drilled in it is the easiest way, or you can have someone hold it carefully in place. Measure the distances marked X1 and X2 on the drawing below, and adjust the 'yaw' of the belly pan assembly until they are the same ($X1=X2$).

Squaring spar assembly to FSLG

Figure 3-6

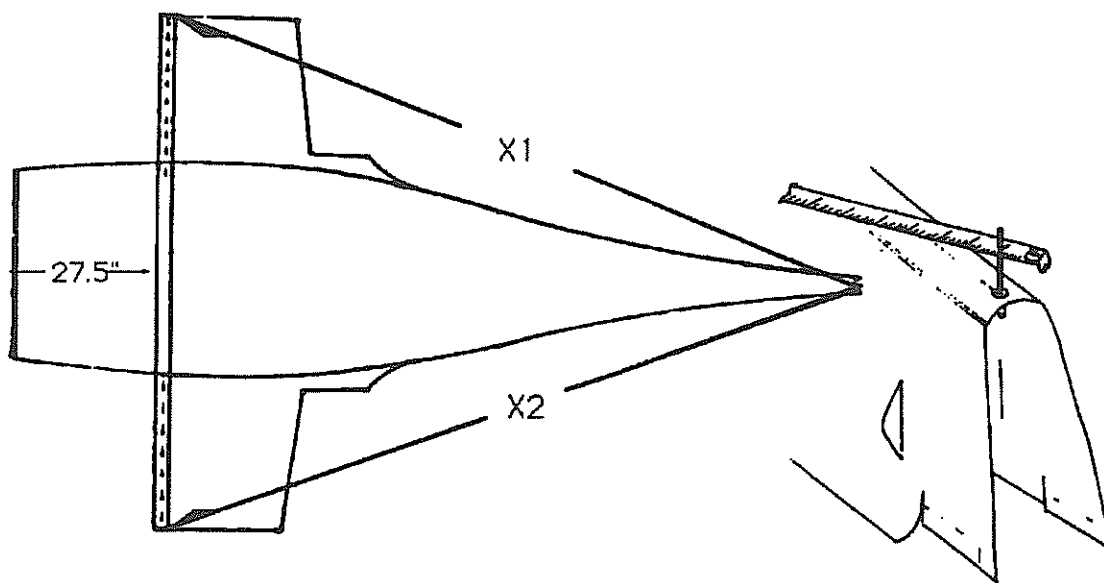

ATTACHING REAR SPAR SUPPORTS TO FSLG

Figure 3-7

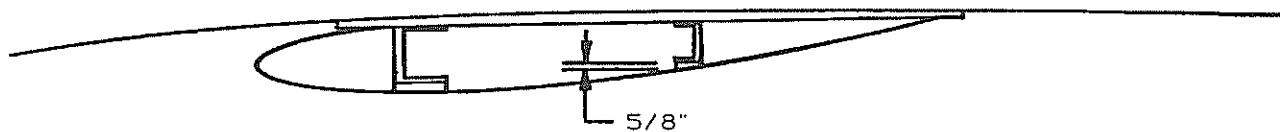

Note: You will find some cleco holes already drilled in the parts. They may or may not line up exactly. For now, they don't matter, and later, if they do line up great use them, but if not, just drill new holes when you need them, don't 'bend-to-fit' the old holes.

16. Now we need the level line on the BL-50 ribs. If it is no longer visible, on blueprint "E" you will find the BL-50 Rib Pattern. Cut out this pattern and carefully transfer the level line from the pattern to the ribs. With this line on and levelled, this will give your wing the proper angle of incidence.

Make sure the fuselage is still level side-to-side and fore-aft. Now, using your water level, you need to make the level line on the BL-50 ribs level with each other and the fuselage. Start with the front edge of the BL-50 rib on one side, and make the other side level with it by either building up or sanding off material from the foam blocks.

NOTE: The purpose of the forward foam blocks is to maintain about 3/8" of clearance between the main spar and the fuselage, space that you will need later when installing the wing skins. If sanding one side would make this distance less than 3/8", then correct the level by adding material to the foam on the other side. Use a 50/50 mix of micro and flox for this. Bear in mind that when you mount the spar assembly in place permanently, you can easily correct small errors at that time just by using a little more 'filler' on one side of the spar or the other, so don't spend a great deal of time to make it perfect right now, just get it within 1/8" or so of level.

To level the BL-50 line, sand or add to the filler blocks supporting the aft spar.

You may notice some small amount of twist between the two BL 50 level lines. If this has happened, don't worry about it at this point, just split the difference between the two sides and proceed. When it comes time to mount the assembly permanently, it can be 'tweaked' a bit to correct.

Also, with such a short portion of the BL-50 rib actually available for a level ref., small discrepancies are not uncommon.

17. Recheck that everything is basically level and square, and note any minor conditions that you'll want to correct during the final epoxying of the spar assembly to the fslg.

Note: If you have the space and extra help, you can be more precise by installing the wings onto the main spar/pan assembly, and checking the level lines at the BL 134 ribs (they may be wiped away - if so, you'll have to transfer them onto the ribs from the blueprints) to make sure each wing tip is level, and from one wing to the other to make sure the whole assembly is level. In order to be sure of

- (1) a smooth transition from the outer wing to the stub wing
- (2) a smooth transition from the stub wing to the fuselage
- (3) a straight hinge area for the flaps and ailerons

At this point, you need to make a few checks on each wing assembly:

WING ALIGNMENT CHECKS

Before attaching the belly pan (or center wing section) to the fslg, the outbd wing panels must be installed on order to verify alignments, primarily at the aft end of the wing panels where flaps and ailerons are going to be attached later.

19. Temporarily bolt the outbd wing panels to the belly pan section and install this complete wing assembly into the fslg. Just snug up the 1/2" attach bolts, they don't need to be torqued down for this alignment check.

You'll need a little help for this. Obviously this assembly will take up some room but the outbd wing panels do not have to be attached for very long so it should be OK if one wing sticks out of the garage door for the time being.

CHECK WING INCIDENCE

20. With the complete wing now bolted up and in position, it is a good time to make a few quick checks of incidence. This is best accomplished at the wing tip rib stations.
21. Establish the wing tip chord lines on the ribs. You may have to go back and transfer them back onto the rib sections using your full size blueprints.
22. The easiest approach to verifying that the left wing is like the right is to use a water level from tip to tip. Check the tip L.E. position left to right with a water level. If they don't match up, simply shim the wing under the fslg fillet pads until the tips do align with the water level. The required shim stock under a fillet will be real thin, if needed at all.

Now check the wing tip T.E. alignments from left to right. With the L.E. already aligned, the T.E.'s should also align. This will quickly and easily verify that the wing washout (or twist) is identical and that is of the most primary importance over all other measurements.

NOTE: The wing tips can be twisted a small amount at this time since the bottom skins have not yet been attached. Once they are bonded on, the wing will become very rigid. If any additional twisting adjustments are needed, you'll now know that it is indeed possible to achieve. This will also affect the wing T.E. skin alignments slightly.

CHECK TOP WING SKIN T.E. ALIGNMENT

23. This top wing skin trailing edge alignment is important from mostly a cosmetic viewpoint since a straight line (as measured spanwise) will mate best with the rolled leading edge of the top flap skin. The aileron will require a straight section for hinge alignment on the top T.E. wing skin but that is only a 35" long section and is quite easy to make straight. Thus, the spanwise area where the flaps locate is of most concern here.
24. At the wing tip, and measuring approximately 8-9" fwd from T.E., place one end of a string line. Run the other end inbd to the fslg fillet at a point approximately 12" fwd from wing root T.E. Your string line inbd should attach at the middle of the double joggle that's on the fslg fillet which will then represent the top surface of the stub wing skin (and that top surface is what we care about in this step). See figure 3-7.
25. The string line should remain tangent to the outbd wing skin surface and remain at least 1/4" to 5/16" off of the aft center spar cap as measured along the belly pan section. That will allow room for the stub wing skin which is about 1/4" thick.

NOTE: Since the aft spars are not yet locked together at BL-50, some alignment adjusting is available here which will affect both incidence and wing skin T.E. alignments. Also, the fslg fillet pads can be adjusted slightly to effect a good string line.

CHECK BOTTOM WING SKIN T.E. ALIGNMENT

26. In a similar manner, the bottom wing skins must align in a straight spanwise manner. The priorities are actually reversed with these since the bottom wing skin at the aileron is primarily cosmetic but the bottom wing skin line at the flap is important since the flap hinges on the bottom and needs a straight line to prevent binding. It can however tolerate a little angularity since it only rotates through 40° and not very often at that.
27. Similar to step 24 above, place a string at the bottom skin line (you'll have to simply use the tip rib since the bottom outbd wing skin is not yet fitted, nor is the outbd aft spar web so disregard those as they are likely over size at this time).
28. Run the string line inbd to the root of the flap along the hinge line which is 12" fwd from the wing T.E. at this inbd station. See figure 3-8.

The goal is to achieve a steady contact of the string line (from BL-50 and inbd) along that lower wing skin (that is already attached and integral with the belly pan).

NOTE: this inbd lower wing skin T.E. is quite flexible since it overhangs aft of the center aft spar. Therefore it can be adjusted up or down to help achieve the proper alignment. A good time to make this alignment permanent is when bonding in the additional BID tapes that will secure that T.E. skin to the inbd aft spar web.

So, at this time, all you need to know is that a good straight alignment is "possible".

29. Once you have made these check and know that all alignments are achievable, you are then ready to permanently bond the belly pan section into the fslg.

WARNING: Do not use pop rivets for any attachments to the spar caps. DRILLING HOLES INTO THE SPARS WILL TOTALLY DESTROY THEIR STRUCTURAL INTEGRITY. Use only moderate weights and/or clamping pressures for bonding purposes. Never use any amount of pressure which would result in deformation of the spar shape due to that application of weight.

30. When you are satisfied that all is in the correct position, see if any of the cleco holes line up. Put an X over any that don't to prevent any confusion, and go ahead and drill some that do, remembering the warning above.

31. With everything ready, you can now permanently bond the belly pan. Use 9339 Structural Adhesive along the glass to glass bond lines and micro where the foam filler pads are located. Refer to the notes you made earlier about the little variances, and remember to add a little adhesive or micro to the spots that will need it.

You should have time to recheck your levels and block or sandbag everything so that it is in the proper position before everything sets up.

Use suitable clamps/weights to secure the belly pan during cure. Duct tape works well to hold the aft fillets together during cure. Use pop rivets along the aft joggle.

WING/BELLY PAN ALIGNMENT

Figure 3-8

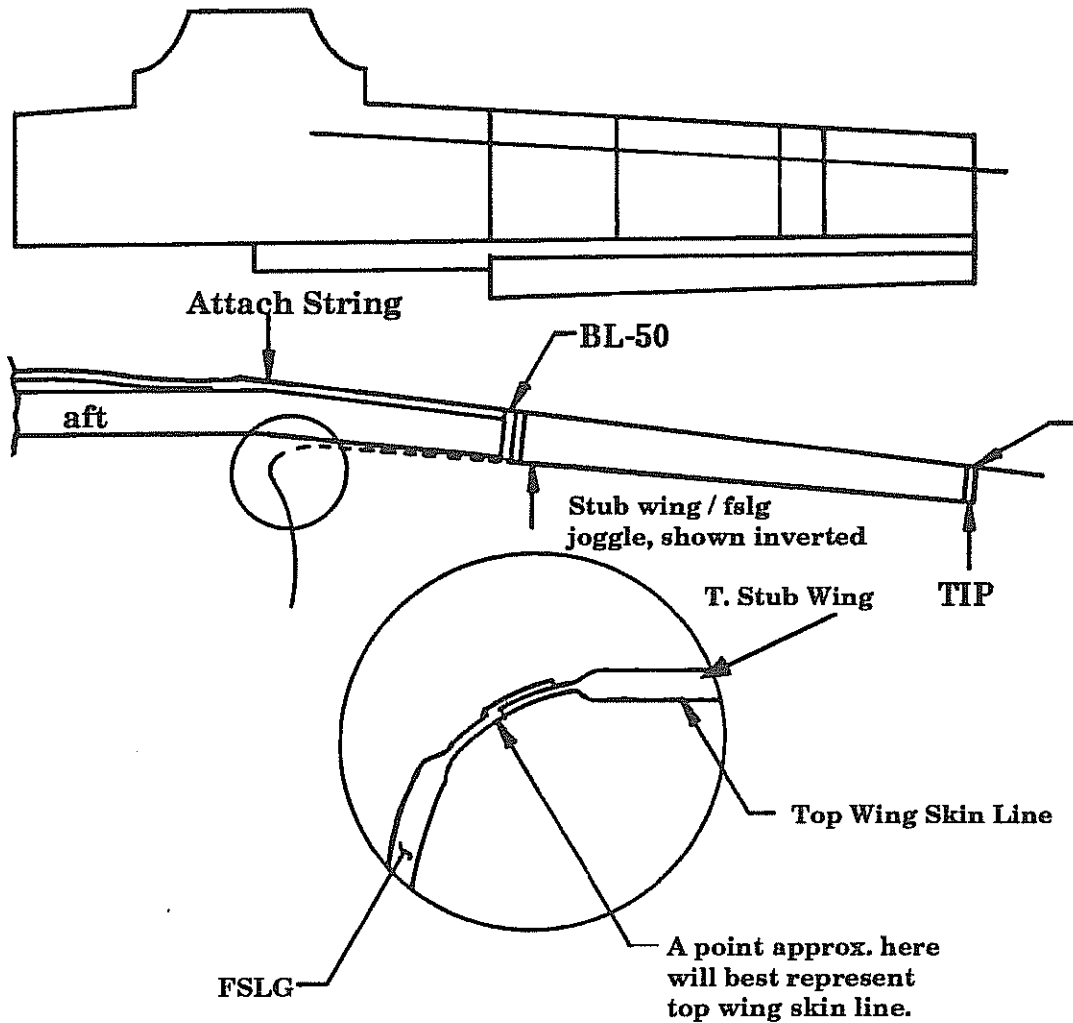

- 31.1 When bonding the belly pan into permanent position, note that with the Super-Fast-Build kit, the forward load transfer pad is already installed onto the fuselage side. It contains the section which also transitions horizontally onto the center main spar cap. Use the 9339 paste adhesive to secure this section onto the center main spar cap. See fig. 3-8-a

fwd load transfer pad attach

fig. 3-8-a

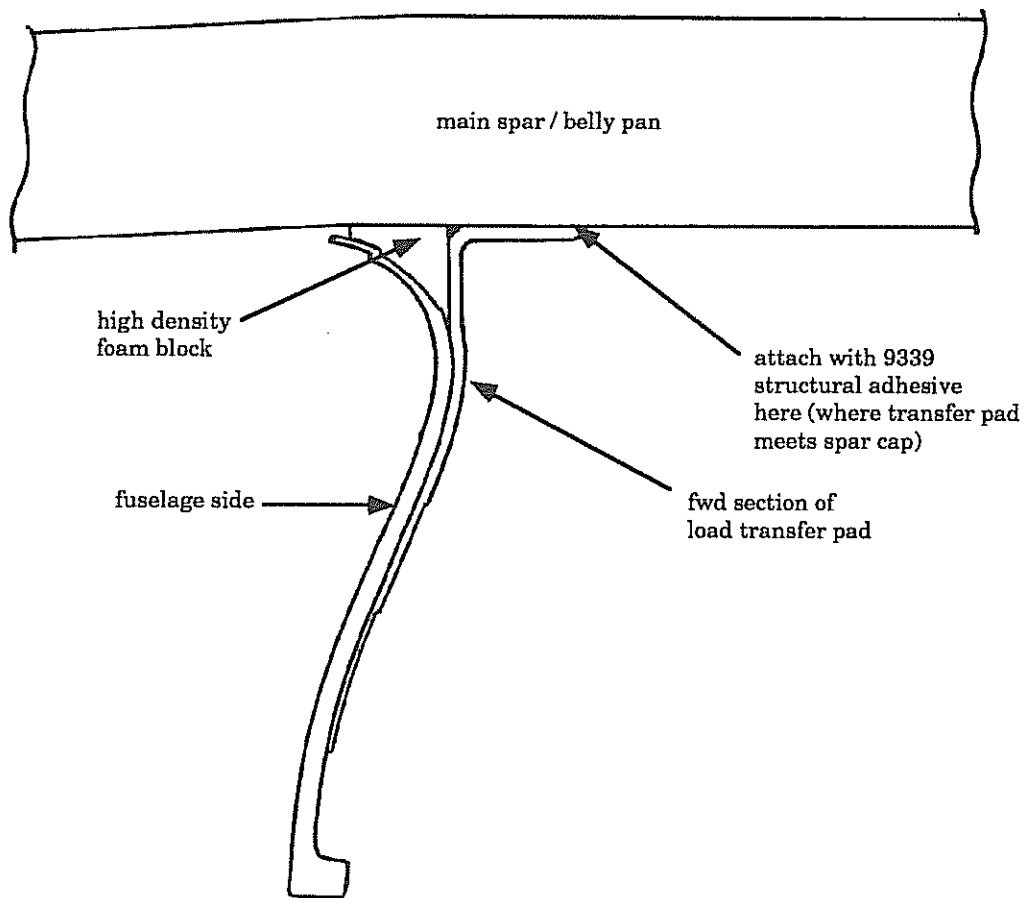

32. After cure, drill out the aft pop rivets, prepare the surfaces and add 2 BID to the aft joggle. Add 2 BID to the fwd joggle seam where it butts to the central fslg *only*, see figure 3-8.
33. 2 BID will also be applied along the aft fillets but you should wait until you have fitted the flaps, which will let you allow for slight fwd/aft fillet T.E. adjustments prior to application of those BID tapes.

Note: to prevent an interference fit later, while your wings are still in place go underneath the plane and mark the outline of the wing spar on the main spar using a pencil. You will be using 3 BID to bond the main spar to the fslg in this area, and you want to be sure to avoid putting BID tape between where the spars will mate to each other.

34. After the BID tapes have had sufficient time to cure, **TURN THE PLANE RIGHT SIDE UP**. Removing the wings first will make it much easier!

BELLY PAN INSTALLATION

Figure 3-9

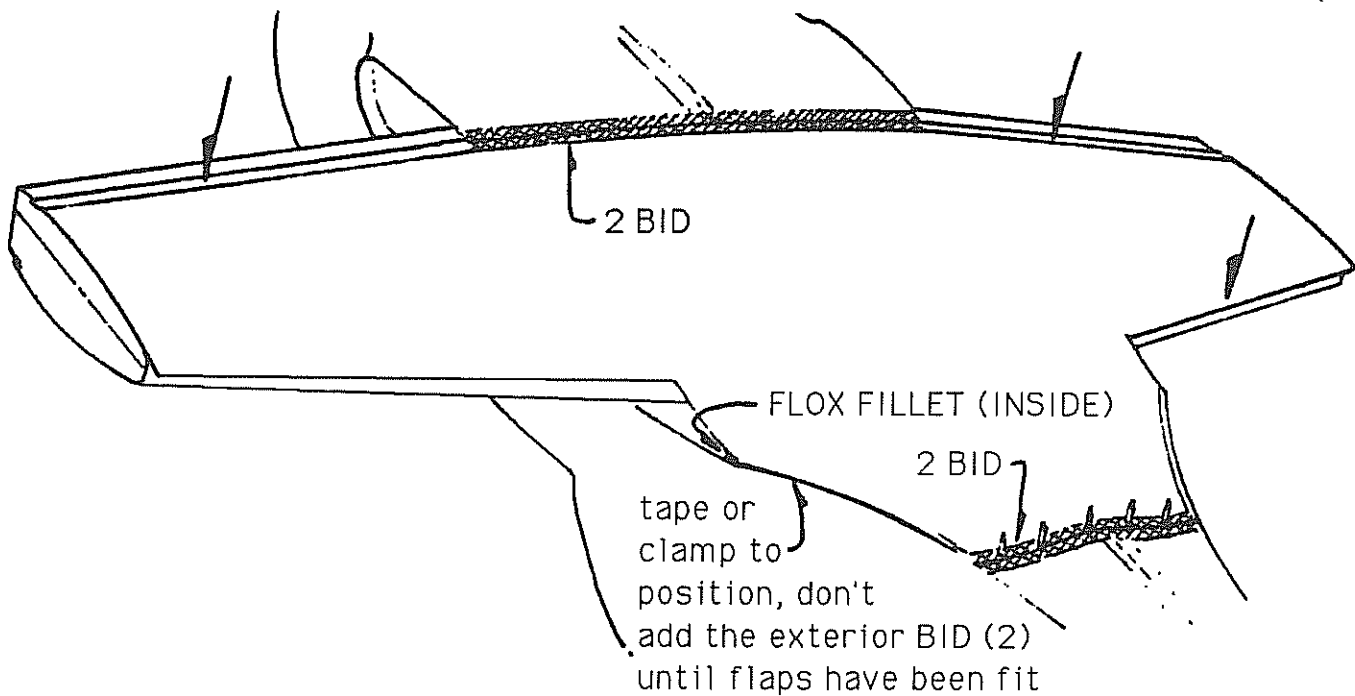

35. Prior to installing the BID tapes in steps 36 & 37, use an epoxy/micro mix to fill in any gaps between parts in the area the BID tapes will go, so you will have a smooth 3/16" radius instead of a 90° angle to lay the tape into.
36. Using a 3 BID tape, bond the fwd web face of the Main Spar to the fslg center section bottom, being careful to not put BID tape in the area of the wing spars you outlined earlier.
37. Using 2 BID, bond the aft web face of the aft spar to the belly pan, from the flap line outboard.



3-20

Chapter 3 REV. 0 / 11-1-91
 FUSELAGE/MAIN SPAR ASSEMBLY



CHAPTER 4: WHEEL WELL PREPARATION

REVISIONS

From time to time, revisions to this assembly manual may be deemed necessary. When such revisions are made, you should immediately replace all outdated pages with the revised pages. Discard the out dated pages. Note that on the lower right corner of each page is a "revision date". Initial printings will have the number "0" printed and the printing date. All subsequent revisions will have the revision number followed by the date of that revision. When such revisions are made, a "table of revisions" page will also be issued. This page (or pages) should be inserted in front of the opening page (this page) of each affected chapter. A new "table of revisions" page will accompany any revision made to a chapter.

Arrows

Most drawings will have arrows to show which direction the parts are facing, unless the drawing itself makes that very obvious. "A/C UP" refers to the direction that would be up if the part were installed in a plane sitting in the upright position. In most cases the part shown will be oriented in the same position as the part itself will be placed during that particular assembly step. However, time goes on and changes are made, so careful attention should be paid to the orientation arrows. That old cartoon of the guy agonizing over the plans for his canoe, built one end up, one end down, should not happen in real life. Especially to you.

CONTENTS

1. INTRODUCTION
2. DRAWING LIST
3. SPECIAL PARTS, TOOLS & SUPPLIES LIST
 - A. PARTS
 - B. TOOLS
 - C. MATERIALS & SUPPLIES
4. PROCEDURE
 - A. COCKPIT CLOSEOUT RIBS
 - B. RECOMMENDED FSLG JACKING POINTS
 - C. CTR SPAR LOAD TRANSFER PADS

LANCAIR® 320FB

4-1

Chapter 4

REV. 0 / 11-1-91

WHEEL WELL PREPARATION

1. INTRODUCTION

This short chapter will see you through the sealing off of the cockpit from the wheel wells, and guide you in the preparation of the load transfer pads that transfer fuselage load to the wing.



2. DRAWING LIST

4-1	page	4-7	Cockpit closeout rib
4-2	page	4-8	Gear door area
4-3	page	4-9	Cockpit closeout rib
4-4	page	4-10	Cockpit closeout ribs
4-5	page	4-11	Cockpit closeout ribs
4-6	page	4-12	Outbd seat belt installation
4-7	page	4-14	Installing hard points for FSLG jacking points
4-8	page	4-15	Load transfer pad
4-9	page	4-16	Forming temporary "dam"
4-10	page	4-17	BID plan for transition web
4-11	page	4-18	Trimming fillet area
4-12	page	4-20	Cockpit closeout rib

3. EQUIPMENT REQUIRED

A. Parts

- Landing gear assembly, main
- (2) AN970-4 washer
- (2) AN4 bolt



4-4

Chapter 4	REV. 0 / 11-1-91
WHEEL WELL PREPARATION	

B.

Tools

- Drill motor
- Drill bits:
 - 1/4"
 - 5/8" (or hole cutter)
 - 7/8" (or hole cutter)
- Tape measure
- Utility knife



- C. Materials & supplies**
- 1/4" phenolic material
 - BID material
 - Epoxy
 - Micro
 - Flox
 - .090 Aluminum material
 - 2 BID prepreg panel
 - Duct tape (for release)
 - Instant glue
 - Peelply or similar



4-6

Chapter 4

REV. 0 / 11-1-91

WHEEL WELL PREPARATION



4. PROCEDURE

A. Cockpit Closeout Ribs

The cockpit closeout ribs will seal the cockpit off from the landing gear wheel wells. They will also be used for the outbd seat belt attachment and the inbd main gear door hinge attachment. To begin the following steps, your fuselage assembly should be right-side-up, level and well supported.

Cockpit closeout rib

Figure 4-1

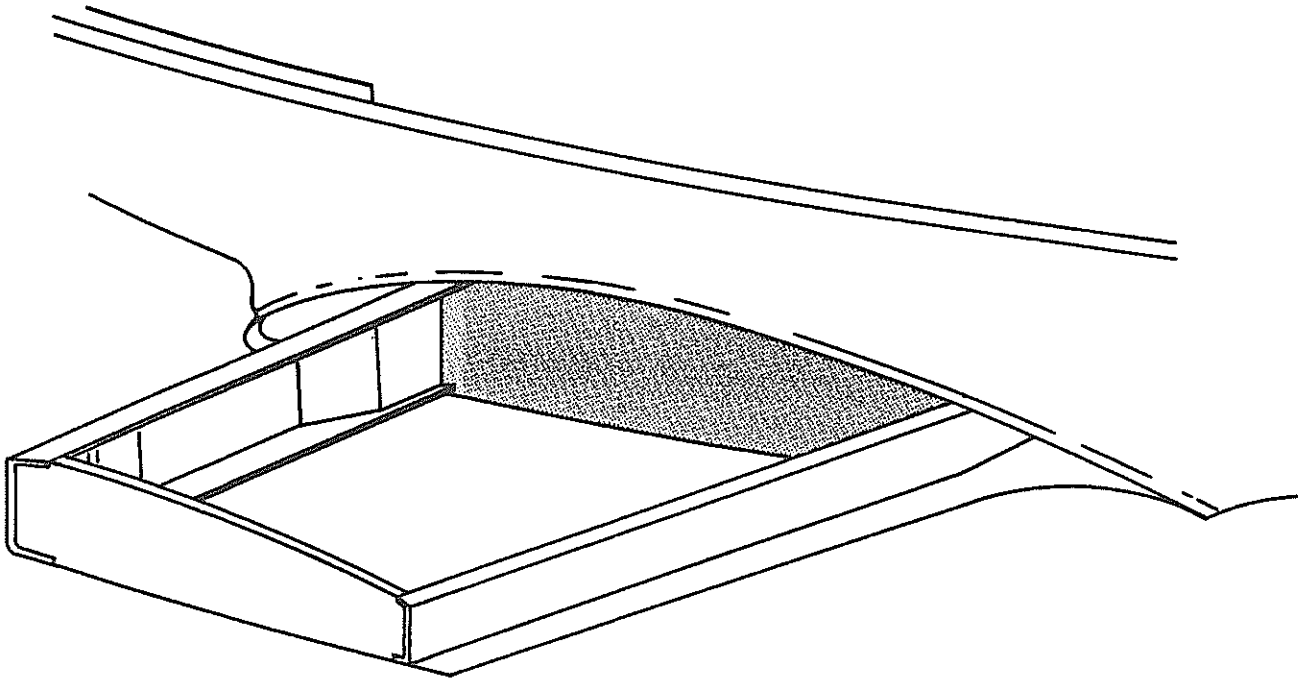

1. The closeout ribs (see blueprint "K") will install at approximately BL 19.25 (measured along their most outbd lower face). This rib position is primarily dictated by the required clearances for the landing gear when retracted. Before installing the closeout ribs, check the required dimensions on Blueprint "B" which has the gear door cut out pattern.

NOTE: The closeout rib will be installed with an outward "lean" of 6-12°s (i.e., the lower surface of the rib is more inbd than the upper surface). This lean should be established to provide adequate clearance for the tire when fully retracted. A fit check using the gear should be made to make sure you've got adequate clearances for the gear when retracted. The rib should be positioned perpendicular to the main spar since this will establish the inbd gear door axis.

There should be 3/8" clearance from the wheel to the closeout rib when the gear is retracted. You can install the landing gear assembly in a temporary fashion by simply inserting the gear in the GM4 fwd attachment and positioning the fwd to aft strut perpendicular. Lay the gear on the belly pan and check for tire clearances from the closeout rib.

Gear door area

Figure 4-2

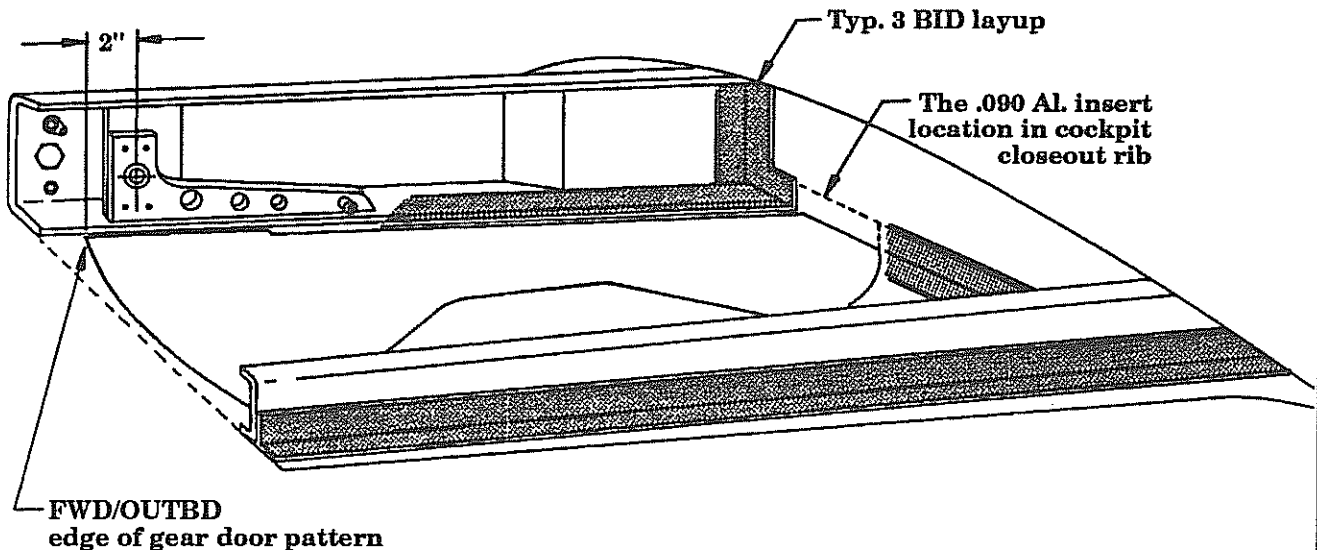

2. Fit the .090" aluminum into the outbd faces of the cockpit closeout ribs per figure 4-3. If you are using foam core ribs, see figure 4-4; if you are using the honeycomb prepreg panels, figure 4-5 shows an acceptable approach to potting in the aluminum.



- Pot in the 1/4" phenolic for the outbd seat belt attach per figures 4-3 and 4-6.

NOTE: Prior to installing the cockpit closeout ribs, read section 4.B. on "Fslg Jack Points", page 4-13.

- With the fit established, pot the ribs into position in the usual manner using micro.
- Add 3 BID around the junctures of ribs to fslg (using 3" wide tapes). Add 3 BID to the rib to spar junctures (except where the load transfer pads will later be installed - do not add any BID there at this time).
- Add the additional BID ply schedule to form the outbd seat belt attach point. See figures 4-3 and 4-6.

**Cockpit closeout rib
Figure 4-3**

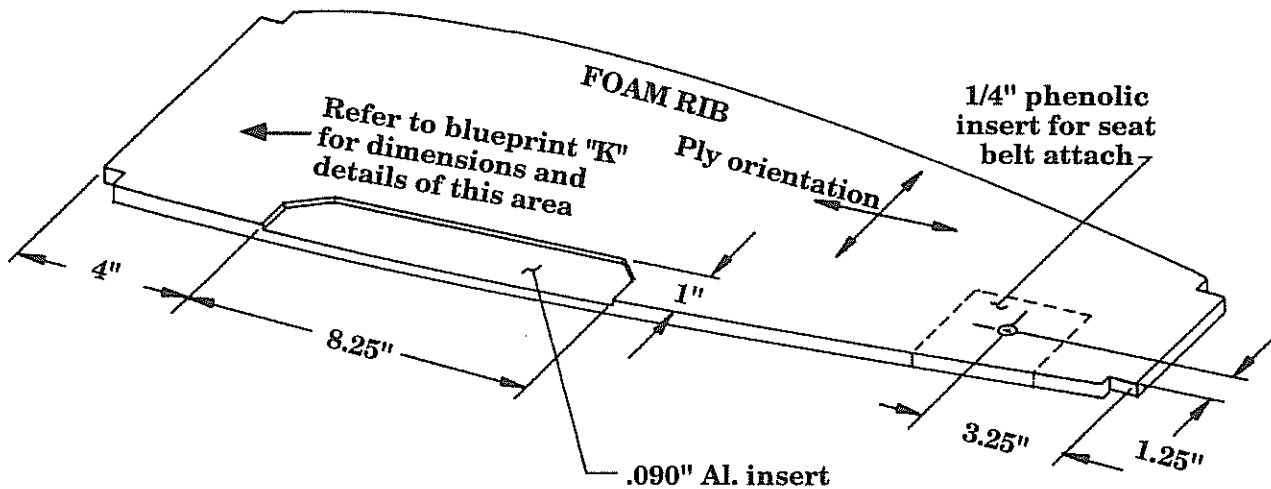

- Add 3 BID to outboard side of cockpit closeout rib.

NOTE: Do not apply the above BID adjacent on the outbd side where the gear door will be cut out later. It won't do any harm but simply not necessary since that area will be cut out anyway.



COCKPIT CLOSEOUT RIBS

FIGURE 4-4

SHOWING ALUMINUM INSERT FOR INBD GEAR DOOR HINGE INSTALLATION WITH A FOAM CORE RIB

NOTE: The alternate method is considered to be preferred.
This alternate method also allows the installation of
MS24694-S5 machine screws in place of the structural pop-
rivets thus allowing full removal of the inbd gear door hinge sections.

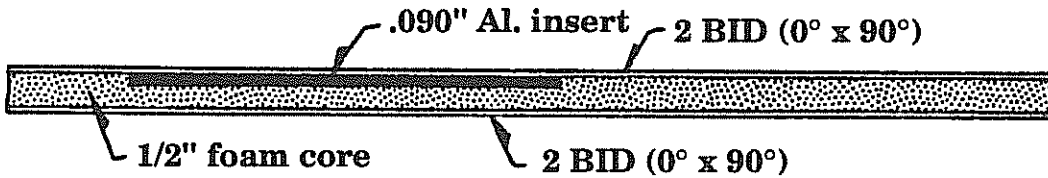

ALTERNATE CLOSEOUT METHOD (PREFERRED)

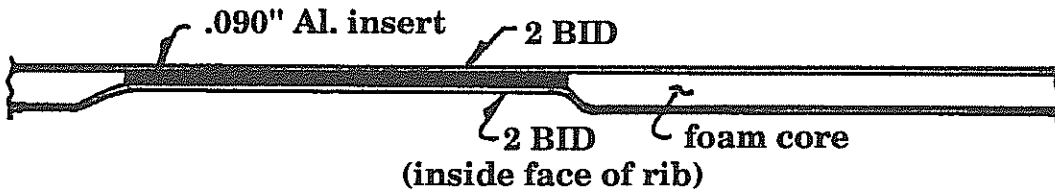

COCKPIT CLOSEOUT RIBS

FIGURE 4-5

USING THE OPTIONAL PREPREG HONEYCOMB PANELS

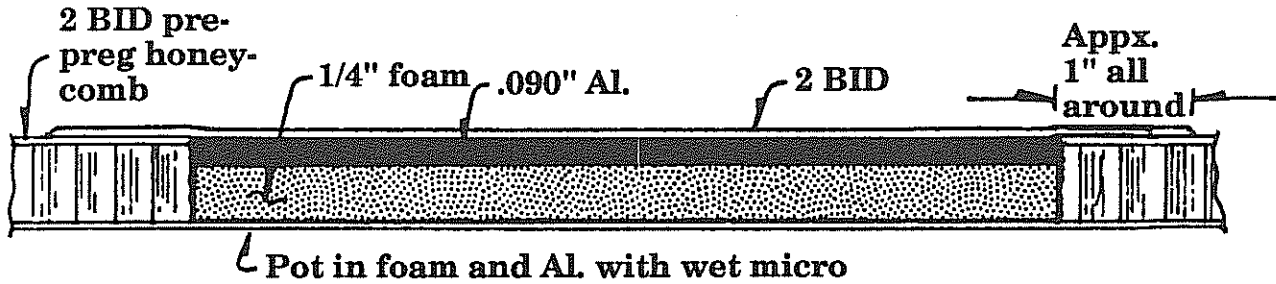

ALTERNATE CLOSEOUT METHOD (PREFERRED)

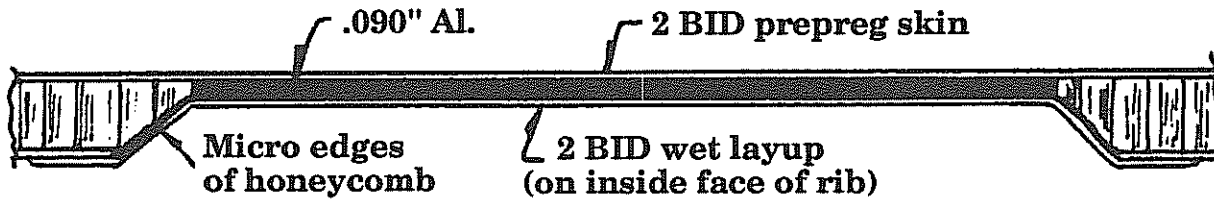

OUTBD SEAT BELT INSTALLATION

FIGURE 4-6

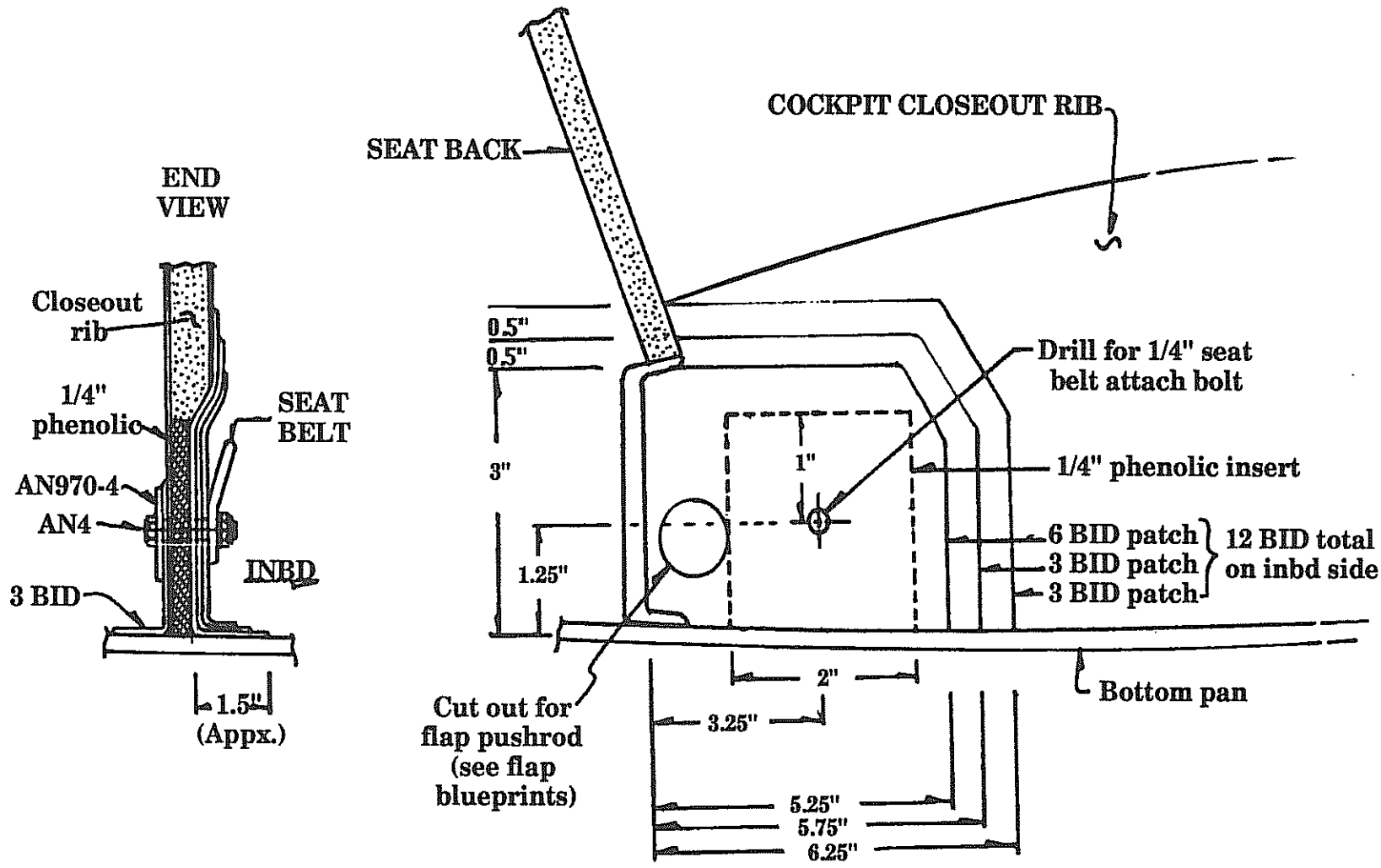

B. Recommended FSLG Jacking Points

It should be obvious that from time to time you will want to jack the plane up to run gear retraction tests. There are several methods acceptable, but this is the preferred method:

1. Mark, on the bottom fslg pan, the location of both cockpit closeout ribs.
2. Per figure 4-7, mark out the area for the 1/4" phenolic or aluminum insert that will go into the bottom pan.
3. Pot these pieces into the bottom pan **prior** to the installation of the cockpit closeout ribs. As the ribs, hydraulic cylinder attachment and load transfer pads are added, a natural jack point will be developed.
4. Drill a 1/4" hole in the center of the insert, which can later be used as a centering pin location for the jacks.
5. Depending on the type of jacks used, fashion a jack receptacle with a 1/4" bolt end in the center for alignment, as shown in figure 4-7. Be sure that your receptacle fits well onto the jack and does not have the ability to slip off!!
6. From these two points the plane can be safely jacked up and off the main gear. The tail will need to be held down to raise the nose gear. The typical approach is to fill a bucket with cement and attach it to either to the tail tie down ring or use a wide strap over the tail cone fwd of the horizontal stabilizer. It does not require too much weight to hold the tail down.



Installing hard points for FSLG jacking points

Figure 4-7

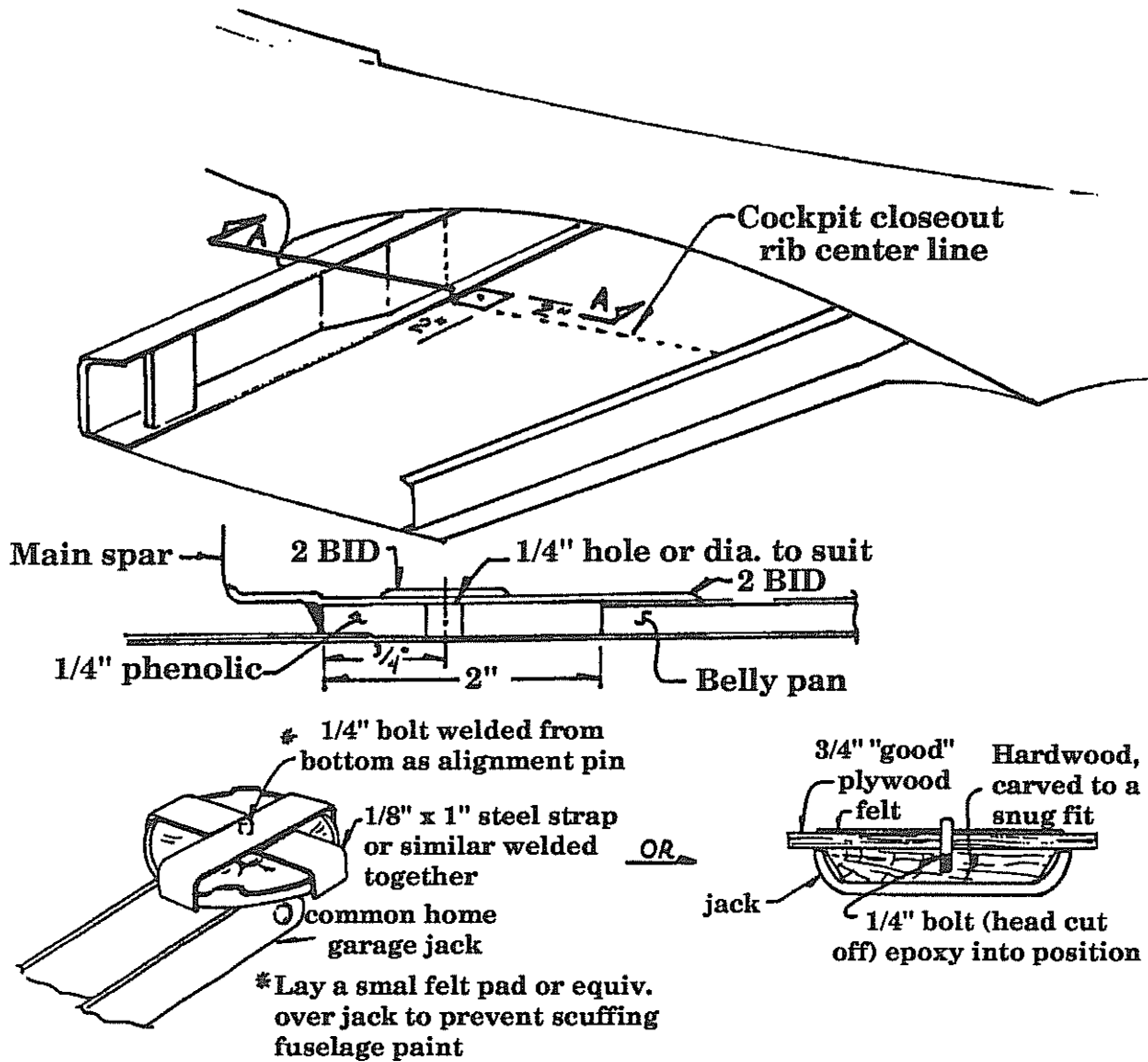

C. CTR Spar Load Transfer Pads

These load transfer pads will transfer the load of the fslg onto the wing which must carry these loads during flight. With the Lancair design, much of the loads such as aux. fuel, main landing gear and pilot/passenger will automatically transfer themselves into the wing directly due to their relative positions.

This will be a multi-layered wet layup performed in two separate stages.

Load transfer pad

Figure 4-8

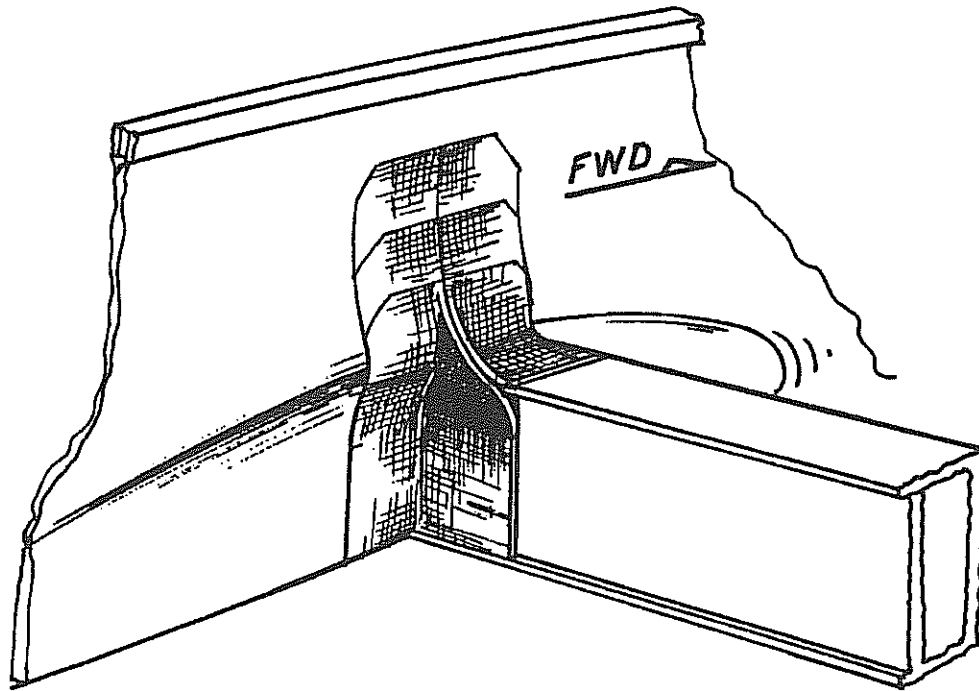

1. Prepare the bonding areas of the fslg, main spar cap, main spar web and closeout rib in the typical manner by roughing up with sandpaper and cleaning with MC.
2. These BID tapes will be applied over the high density foam that has already been fitted into the triangular area between fslg fillet and upper spar cap. This high density foam should be sanded so as to form a smooth transition from fslg fillet (inner cockpit side) to the upper spar cap. A small radius will be required at the spar cap juncture.

3. Form a temporary "dam" that will position on top of the spar cap and against the foam block side per figure 4-9. This can be made of anything handy; scrap foam with a coating of duct tape as a release seems to work well. This may be instant glued into temporary position. Its purpose is simply to provide a surface for the transition web to be laid up on.

Forming temporary "dam"

Figure 4-9

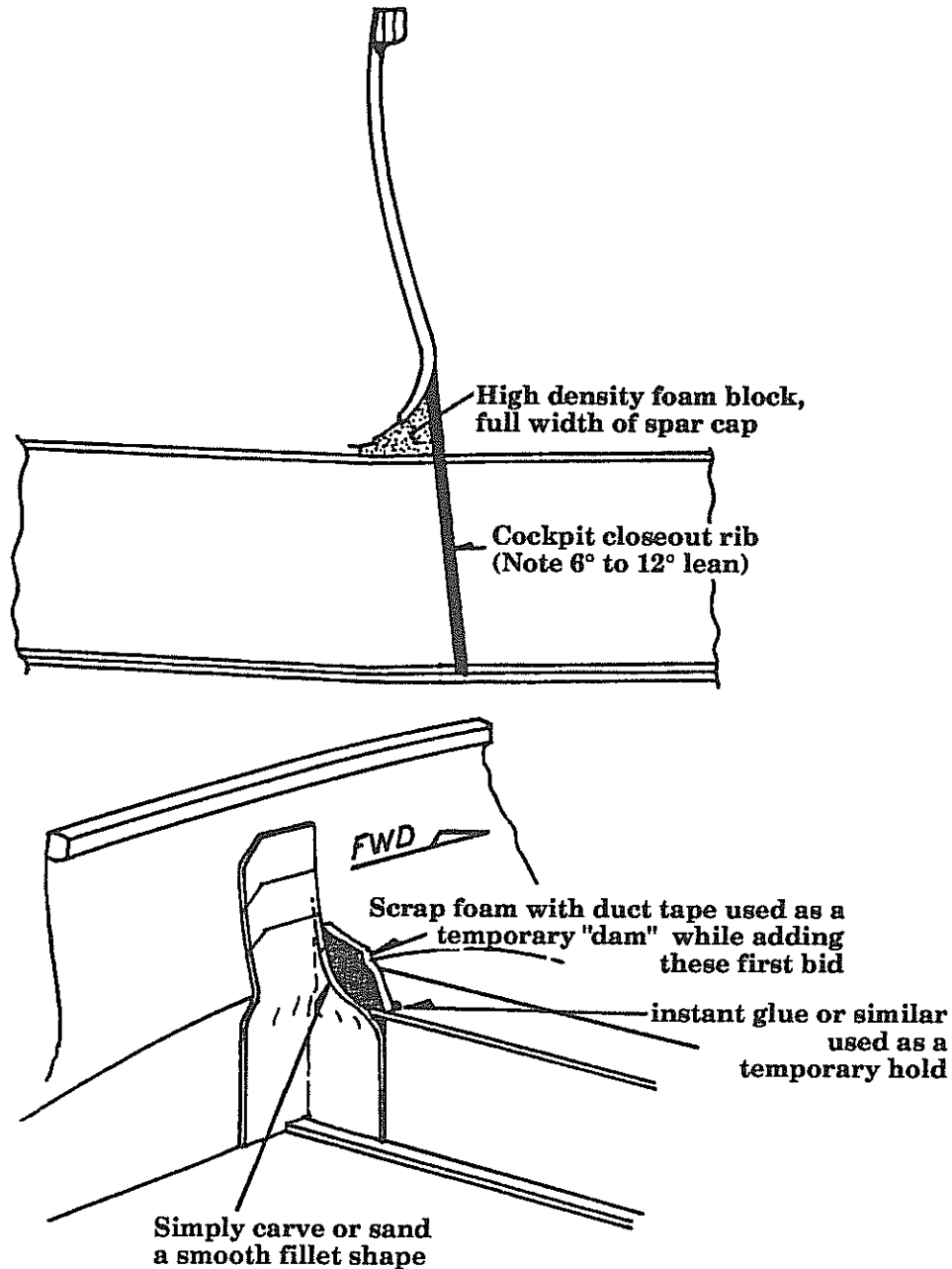

4. The 12 BID layup is best applied in three separate 4 BID applications. Apply the first 4 BID application starting at the fslg bottom extending vertically up the side of the fslg to a point 8" above the top of the spar cap. Be sure to contact 3" of the spar closeout web and 3" of the cockpit closeout rib and fslg side.

NOTE: The area of the spar web just below the top spar cap should have a generous fillet of epoxy/flox to transition from the web to the cap. See figure 4-10. Also note the area of contact on the "dam" which will form a transition fillet from spar web to fslg side. See figure 4-9.

BID plan for transition web

Figure 4-10

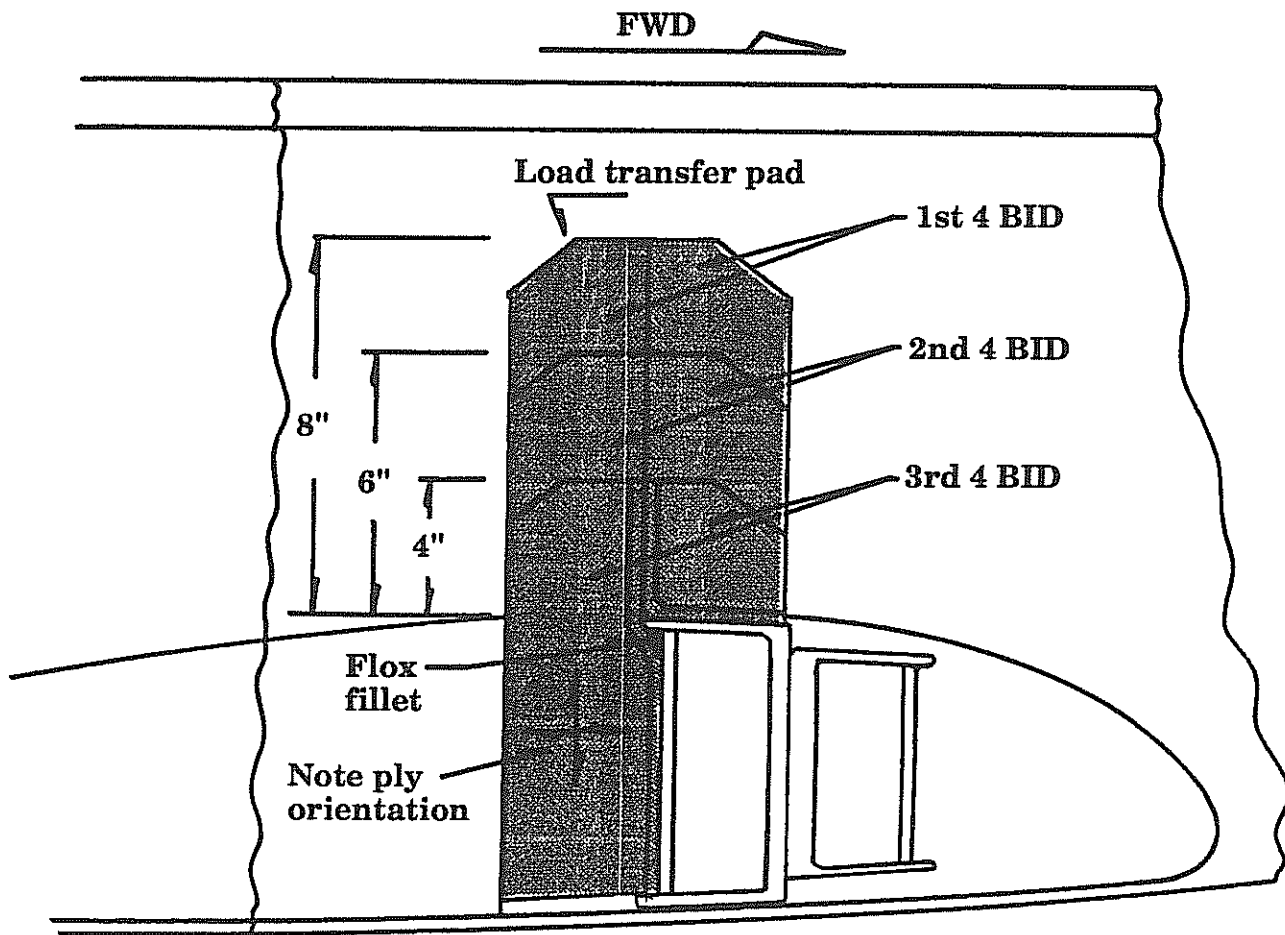

5. Add the next (2nd) 4 BID layup over the first 4 BID layup. It will extend only 6" above the top spar cap.

6. Add the last (3rd) 4 BID layup over the first two. This one will extend only 4" above the top spar cap.

Trimming fillet area

Figure 4-11

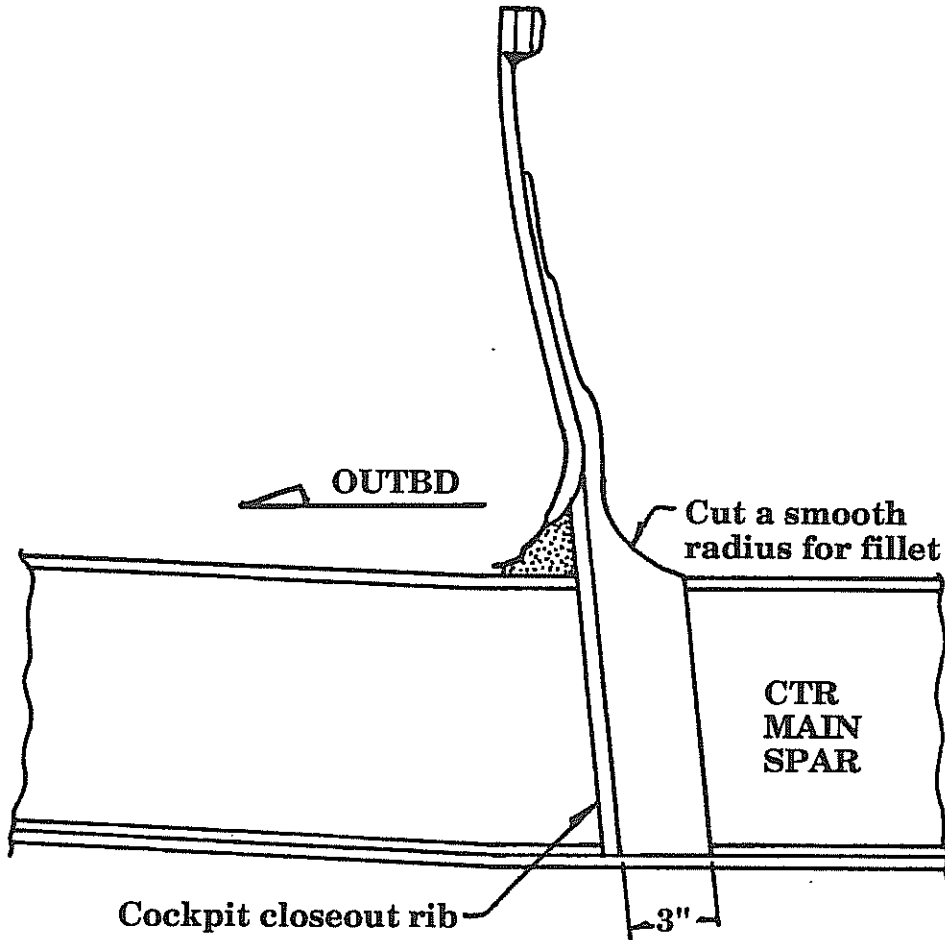

7. It will be advantageous to use peelply or similar over this layup to attain a nice smooth transition of the 12 BID into the fslg side (which will be open to the cockpit). If you don't have "peelply" then use dacron cloth since it's the same thing. The peelply will be applied as if it were an additional layup. When the epoxy has cured, it will simply peel of, leaving a smooth surface underneath.

8. The above layup should be left to cure but the fillet area against the "dam" can easily be trimmed to the proper shape (see figure 4-11) when the layup is in the "green" state. This is usually (depending on temperature) from 4 to 7 hours after application. Use a utility knife for trimming. Allow to cure. (The fillet shape can also be ground in later after cure).
9. Remove the "dam" and clean/prepare the exposed area of the fillet for subsequent bonding.
10. Apply 3 (4 BID) bonding tapes to the fwd area in a similar manner as described above, see figure 4-10. These tapes must contact 3" of the full width of the top spar cap. They will extend vertically up the fslg to match the above described layup.
11. This completed layup may be trimmed along the fillet to match the first 12 BID layup. It too will be easier if trimmed while in the "green" state.
12. Cover with peelply and allow to cure. The load transfer pads are now completed.
13. With the load transfer pads now installed and cured, the access holes can be quickly cut through the closeout ribs for both the aileron push rods (at the fwd end) and the flap push rods (at the aft end).
 You can use a standard circle cutter that chucks up into a hand drill, see figure 4-12 for location and size. Use the final assembly to check for clearances. There must be NO contact between push rods and ribs through the full travel limits.

 NOTE: The flap push rod hole centers (from left to right) are not the same distance from the aft ctr spar web.
14. After you have verified adequate clearances, the core material should be closed out with micro in the standard manner.



Cockpit closeout rib

Figure 4-12

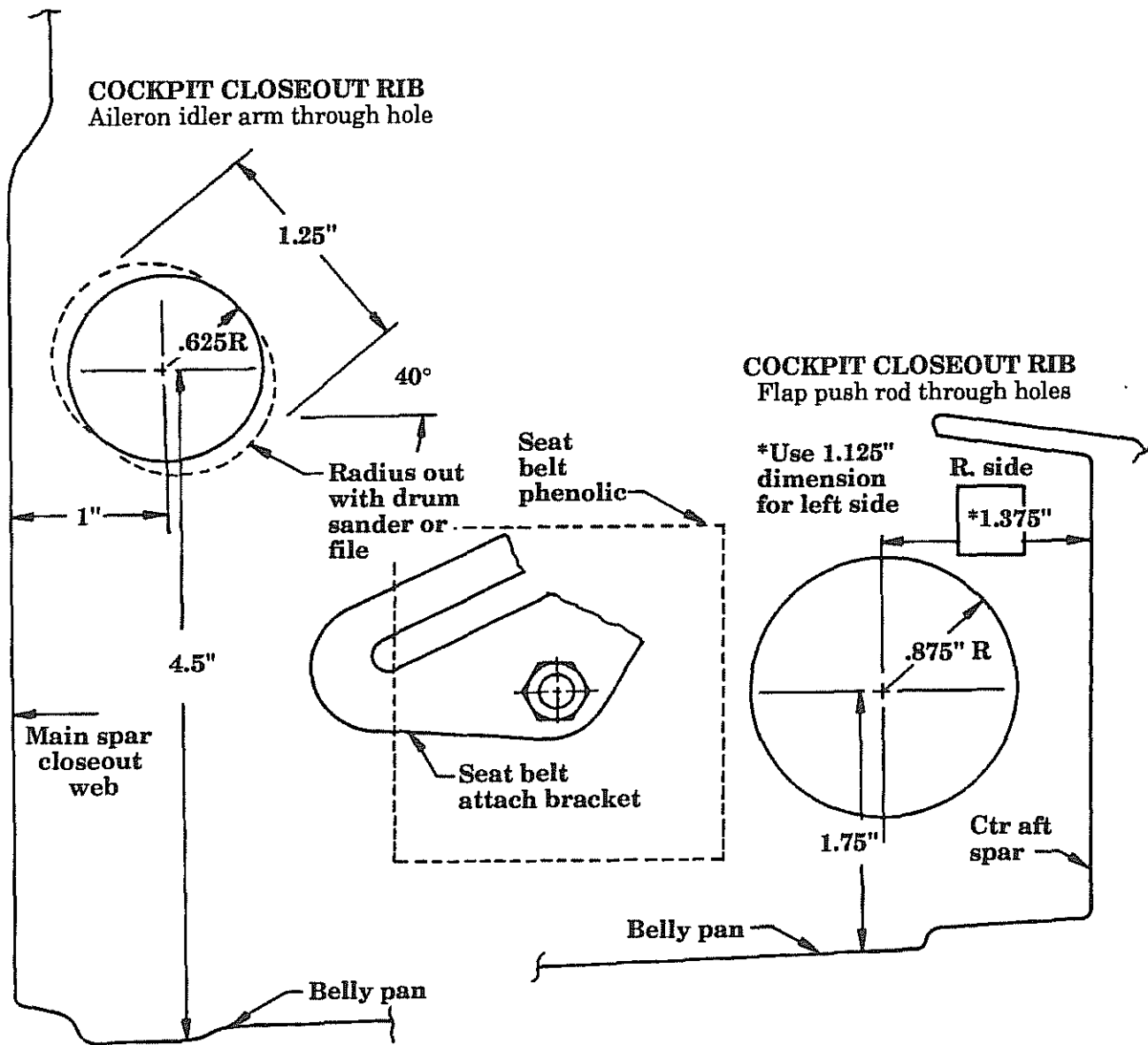

CHAPTER 5: LANDING GEAR INSTALLATION

REVISIONS

From time to time, revisions to this assembly manual may be deemed necessary. When such revisions are made, you should immediately replace all outdated pages with the revised pages. Discard the out dated pages. Note that on the lower right corner of each page is a "revision date". Initial printings will have the number "0" printed and the printing date. All subsequent revisions will have the revision number followed by the date of that revision. When such revisions are made, a "table of revisions" page will also be issued. This page (or pages) should be inserted in front of the opening page (this page) of each affected chapter. A new "table of revisions" page will accompany any revision made to a chapter.

Arrows

Most drawings will have arrows to show which direction the parts are facing, unless the drawing itself makes that very obvious. "A/C UP" refers to the direction that would be up if the part were installed in a plane sitting in the upright position. In most cases the part shown will be oriented in the same position as the part itself will be placed during that particular assembly step. However, time goes on and changes are made, so careful attention should be paid to the orientation arrows. That old cartoon of the guy agonizing over the plans for his canoe, built one end up, one end down, should not happen in real life. Especially to you.

CONTENTS

1. INTRODUCTION
2. DRAWING LIST
3. SPECIAL PARTS, TOOLS & SUPPLIES LIST
 - A. PARTS
 - B. TOOLS
 - C. MATERIALS & SUPPLIES
4. PROCEDURE
 - A. SETTING THE MAIN GEAR COMPRESSION ASSEMBLIES
 - B. MOUNTING THE MAIN GEAR BRAKE ASSEMBLY
 - C. MAIN GEAR PRIMARY AND SECONDARY ATTACH
 - D. MAIN GEAR OVER CENTER LINK ASSEMBLY
 - E. MAIN GEAR DOOR CUT OUTS
 - F. MAIN GEAR DOOR ACTUATION
 - G. MAIN GEAR AFT ATTACH POINT
 - H. ADJUSTING THE MAIN GEAR OVER CENTER LINKS
 - I. NOSE GEAR STRUT ASSEMBLY
 - J. ENGINE MOUNT/NOSE GEAR ATTACH & ALIGN
 - K. NOSE GEAR DRAG LINK INSTALLATION
 - L. NOSE GEAR GAS STRUT INSTALLATION
 - M. NOSE GEAR HYDRAULIC CYLINDER
 - N. MAIN GEAR HYDRAULIC CYLINDER AND ATTACH POINT
 - O. MAIN GEAR CYLINDER ATTACH - PIN KEEPER
 - P. MAIN GEAR HYDRAULIC CYLINDER ATTACH POINT
 - Q. HYDRAULIC POWER PACK INSTALLATION

1. **INTRODUCTION**

The landing gear of the Lancair is of the trailing arm type which is noted for its effective absorption of landing impact energies. This should help greatly to keep one's ego up during landing operations. It was once stated that the Lancair could not be bounced but that statement must reluctantly be stricken from the records. Perhaps it is now best stated that it almost requires practice to successfully get the Lancair to bounce and some pilots simply require less practice than others!!

Main Landing Gear Assembly

Figure 5-1

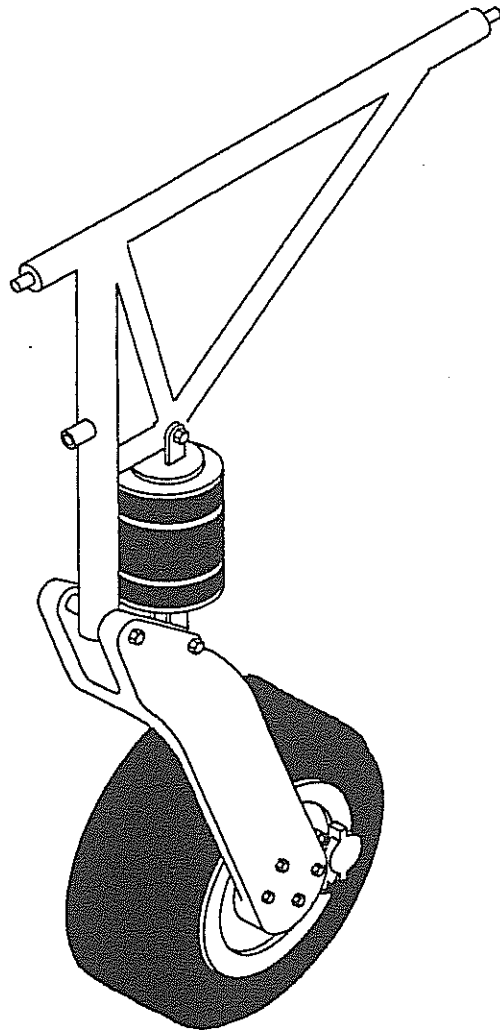

NOTE: The gear legs should be assembled per the LANDING GEAR BREAKDOWN drawing. The assembly is rather straight forward with only a couple of exceptions that require some discussion.

2. DRAWING LIST

fig.	page	description
5-1	page 5-2	Main landing gear assembly
5-2	page 5-7	Main landing gear breakdown drawing
5-3	page 5-9	Compression assembly
5-4	page 5-10	Main gear brake assembly
5-4.1	page 5-11	GM4 (Primary & Secondary) attach bracket
5-4.2	page 5-12	GM4 Position
5-5	page 5-13	Upper arm bearing location determination
5-6	page 5-14	Main gear over center link assembly
5-7	page 5-15	Main gear door cut out location
5-8	page 5-16	Gear door cut angle
5-9	page 5-17	Gear doors
5-10	page 5-18	Positioning gear door hinge tube
5-11	page 5-18	Location of gear door hinge
5-12	page 5-19	Outbd gear door hinge assembly
5-13	page 5-21	Installing gear door hinge
5-14	page 5-22	Forming glass lip for gear doors
5-15	page 5-23	Potting angle bracket in main gear door
5-16	page 5-24	Outbd main gear door push rods
5-17	page 5-24	Drilling main gear leg for rod end bearing
5-18	page 5-25	Positioning landing gear
5-19	page 5-26	Checking tire alignment
5-20	page 5-27	Positioning gear strut to vertical
5-21	page 5-28	Main gear aft attach plate
5-22	page 5-29	Main gear aft attach
5-22.1	page 5-30	Overcenter link, springs
5-22.2	page 5-31	Overcenter link spring attach to weldment
5-22.3	page 5-31	Spring / gear weldment connect π/c
5-22.4	page 5-32	Spring attach to overcenter links
5-23	page 5-33	Attaching springs to gear leg
5-24	page 5-34	Strut clearance and travel
5-25	page 5-35	Nose gear assembly drawing
5-26	page 5-37	Wheel & tire assembly
5-27	page 5-40	Firewall layout
5-28	page 5-40	Nose gear / engine mount
5-29	page 5-41	Nose gear adjustment
5-30	page 5-42	Installing GM attach blocks onto the nose gear strut
5-31	page 5-43	Nose gear adjustment
5-32	page 5-46	Nose gear drag link assembly
5-33	page 5-47	Nose gear tunnel
5-34	page 5-48	Nose gear pivot pin installation
5-35	page 5-48	Drag link / tunnel installation
5-36	page 5-49	Nose gear micro switch
5-37	page 5-51	Nose gear gas strut
5-38	page 5-52	Gas strut attach bracket
5-39	page 5-53	Power pack and pressure switch
5-40	page 5-55	Nose gear hydraulic cylinder attach
5-41	page 5-57	Main gear hydraulic cylinder attach point
5-42	page 5-58	Hydraulic cylinder attach
5-43	page 5-60	Pin keeper
5-44	page 5-61	Main gear hydraulic cylinder attach point
5-45	page 5-61	Locating hydraulic cylinder attach points
5-46	page 5-62	Aluminum mounting plate
5-47	page 5-63	Hydraulic power pack installation
5-48	page 5-64	Gear electrical wiring reference

3. EQUIPMENT REQUIRED

A. Parts

- all parts per "Main Gear Breakdown" drawing
- 1" x 2" aluminum angle stock (21.5" long pcs)
- Structural pop rivets
- 8 MS24694-S7 (or S5) countersunk machine screws
- 8 K1000-08 (8-32) nut plates
- 16 AN426AD-3-6 countersunk (3/32") rivets
- 3/8" x .058 aluminum tubing
- 1/4" aluminum rod
- 4 M34-14 rod end bearings with check nuts (316-4)
- 2 3/8" x .085 Aluminum tubing approx. 1.5" long
- 4 3/32" roll pins
- Main gear door cutout pattern
- 14" extruded aluminum hinge stock
- 3/8" x 8" steel rod



B. Tools

- Electric drill motor, 3/8"
- 3/32" drill bit
- 1/8" drill bit
- 3/16" drill bit
- 1/4" drill bit
- 3/8" drill bit
- #12 drill bit
- #19 drill bit
- #32 drill bit
- 100° countersink
- 1/4" transfer punch or similar
- Saber saw with fine tooth blade
- 3 C-clamp, small
- 2 C-clamp, large (6")
- carpenter's square
- Drill press (optional, but very handy with a drill press vise)
- hack saw
- Band saw, metal cutting (optional)
- Dremel™ type routing tool with 1/8" dia. cutter
- 1/4-28 thread tap
- tap handle
- tape measure
- gear door template (blueprint)
- carpenter's level
- tire pump or air compressor (for inflating tires)

C. Materials & supplies

- duct tape or similar release material
- instant glue
- flux
- micro
- BID materials
- sandpaper, assorted grit
- #10 wire, electrical
- #18 wire, electrical



Main Gear Assembly Drawing

Figure 5-2

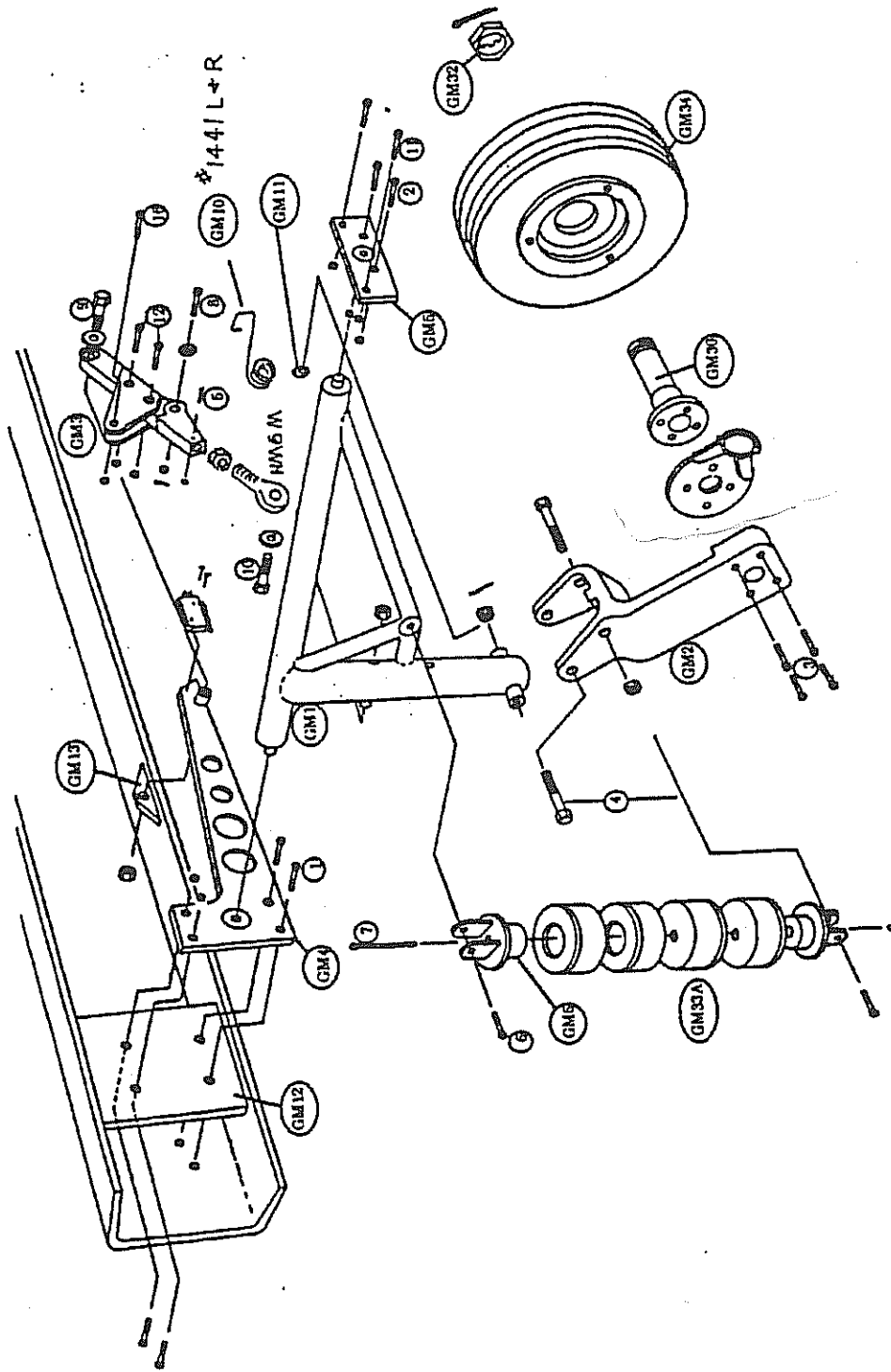

BOLT LIST FOR FIGURE 5-2:

PART #	QTY	Description
1	8	AN4-13A
2	4	MS24694-S106
3	8	AN4-22A
4	4	AN5-42
5	2	AN3-7A
6	2	AN5-15
7	2	AN4-34A
8	2	AN4-10
9	2	AN6-30A
10	2	AN6-32A
11	4	AN4-14A
12	4	AN3-7A
14	2	HM6M rod end bearing
15	2	AN316-6R check nut
16	2	AN3-7a
	1	1441L & R Spring
	4	WS-6 washers
		1-1/4" Shrink tubing sleeve



4. PROCEDURE

A. Setting the main gear compression assemblies

Our latest style of compression assemblies use a donut similar to that used on the Mooney aircraft. In fact, they are made by the same manufacturer. These units provide superior dampening properties. They also have the metal plates vulcanized onto the synthetic rubber-like material. This simplifies the assembly as well.

1. This assembly requires the GM33A (black compression donuts with attached metal plates). Also required are the GM6 compression cap casting and AN4-34A bolts with AN365-428 stop nuts.
2. Note that all the biscuits have one plate with a 1/4" hole and one with a 1 1/4" hole. The large diameter hole will accept the GM6 castings at top and bottom. The middle two biscuits will be orientated such that the thicker plates (with the large diameter holes) are AWAY from the center. See figure 5-3.
3. Slip the AN4-34 bolt through and align the pieces. Use a pair of large C-clamps or cabinet clamps to squeeze the biscuits until the AN365-428 nut can be screwed on. Set the "ears" of upper and lower GM6 casting parallel by twisting and making a visual inspection until a close parallel condition is established.
Set the amount of compression such that the holes in the GM6 castings measures 6" from center to center. Locate the nut to the bottom of this assembly. Mark that bottom end for later reference.

NOTE: When assembling the compression assembly, use two washers under the AN4-35A bolt head and one washer under the nut. Otherwise you will run out of threads.

Compression assembly

Figure 5-3

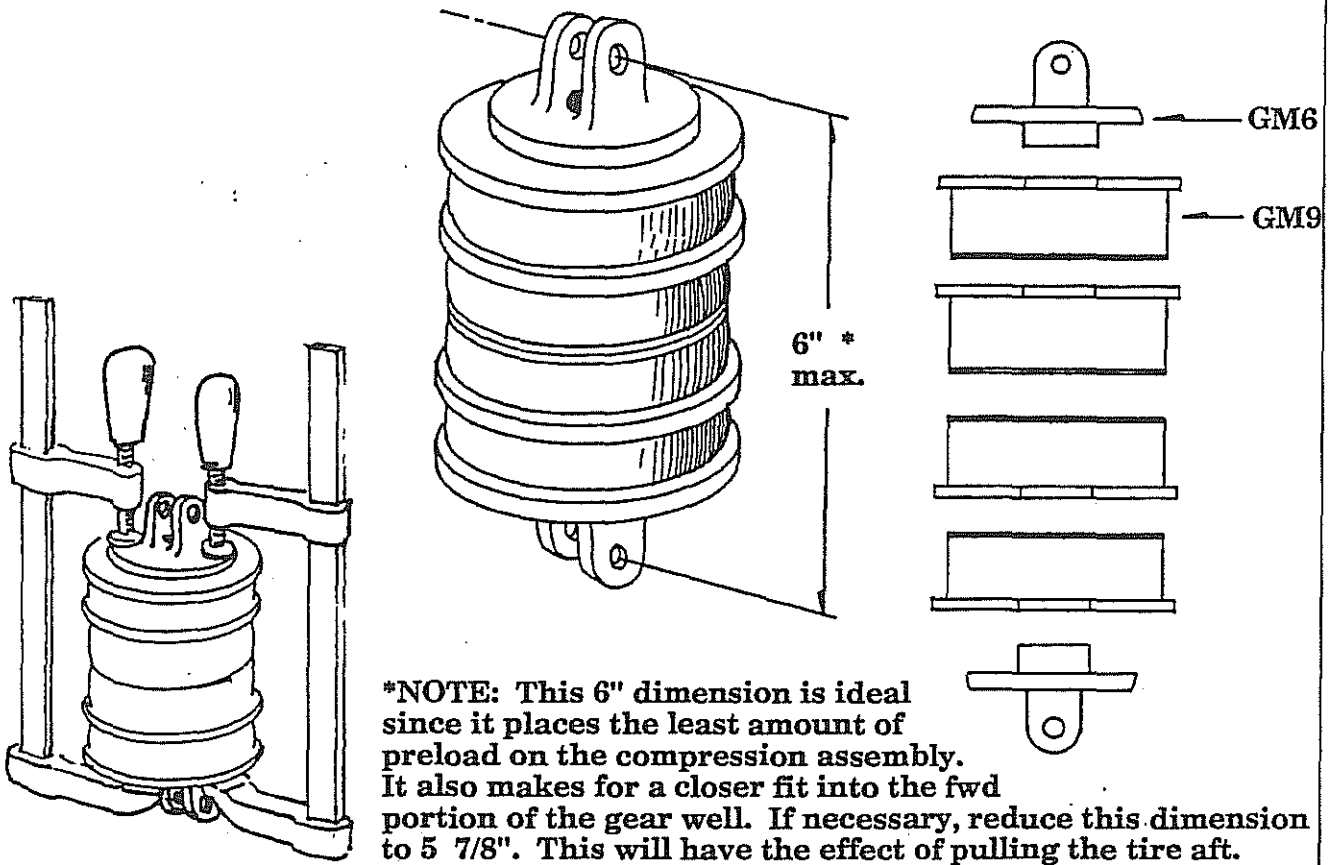

- B. **Mounting the main gear brake assembly**
This is also straight forward.

Main gear brake assembly

Figure 5-4

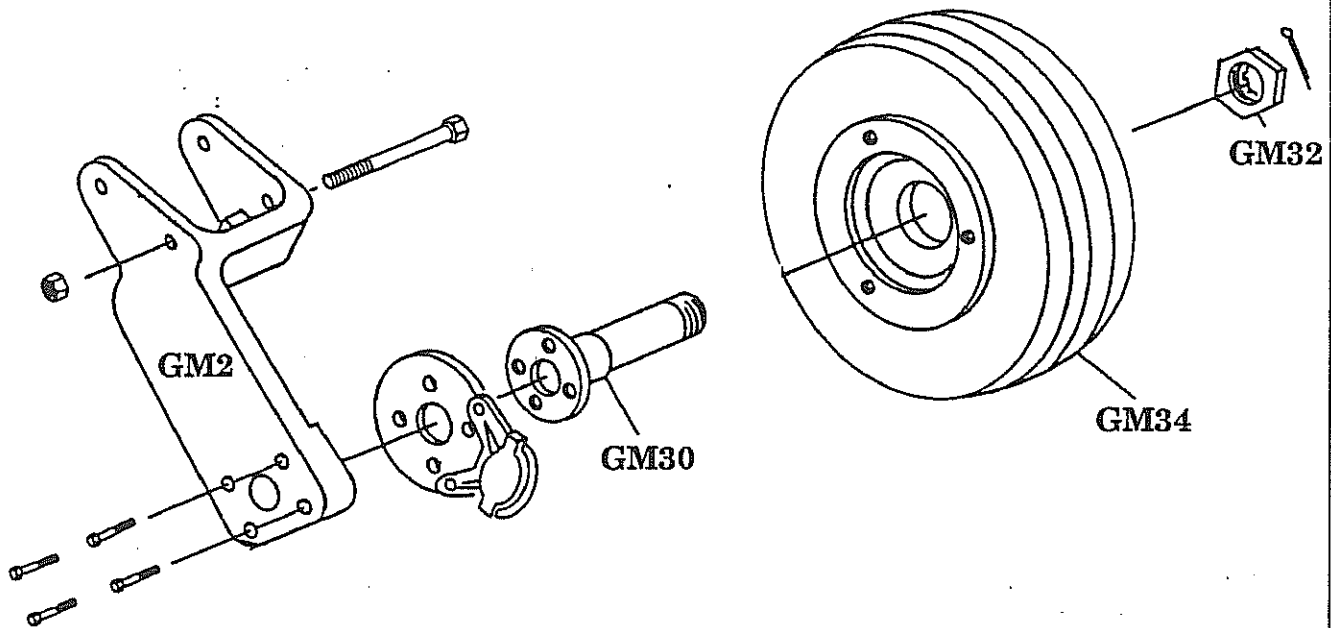

1. Assemble the brake/axle assembly onto the gear leg casting as shown in figure 5-4. The small 1/8" boss on the back of the axle will center into the brake alignment disk for mounting. Place the bolt heads outside of the gear leg casting for maximum gear door clearance.

- C. **Main gear primary and secondary attach points**
1. Select the GM4 main gear alignment brackets. These aluminum machined parts will establish the proper alignment of the main gear pivot point with the overcenter link pivot point. They will be mounted to the GM12 phenolic which has been bonded into the center main spar.

GM4 alignment bracket

Figure 5-4.1

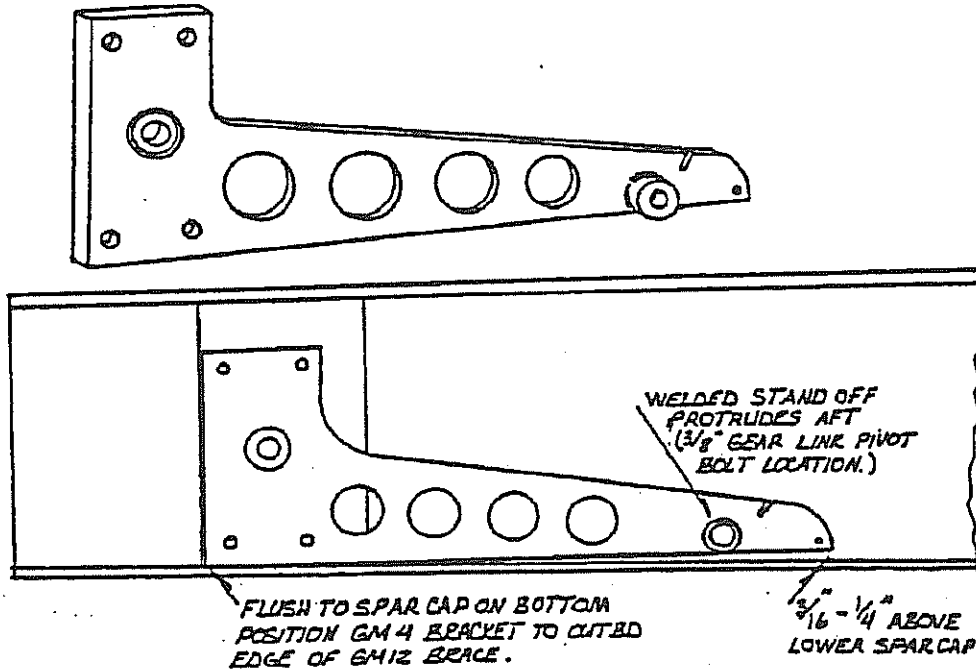

2. Position the GM4 bracket per figure 5-4.1. The lower edge of it will rest on the lower spar cap but the inbd end should be elevated slightly to provide adequate clearance for the 3/8" nut on the fwd face of the phenolic. Also note that the GM4 should have the welded standoff facing aft.

3. Drill and mount the GM4 bracket using the four 1/4" bolts. Set them with the nuts on the aft side to provide clearance for the aileron push rod which will operate on the fwd side. Drill for the 3/8" pivot bolt on the inbd side of the GM4. Be careful not to rock the drill bit when drilling through the GM4 because that could wobble out the hole and make for a sloppy fit. The overcenter link will attach to this position later.



5-12

Chapter 5

REV. 4/1-23-96

LANDING GEAR INSTALLATION



D. Main gear over center link assembly

1. Per figure 5-6, press the roll pin to trip micro switch into position. **BE SURE YOU PUT IT IN THE CORRECT SIDE OF THE LINK. IT MUST BE ON THE FORWARD SIDE (THE SIDE OPPOSITE THE SHOULDER WHERE THE GM4 MOUNTS).**
2. Assemble the over center links per figure 5-6. Use care to position the nuts on the appropriate sides of the links, since this is important for clearance purposes.

IMPORTANT: It is mandatory that the side of the upper arm with the shoulder be positioned so as to be on the AFT side of the assembly when fitted to the airframe.

FAILURE TO ACCURATELY ESTABLISH THIS ABOVE CONDITION COULD RESULT IN A JAM WHEN CYCLING THE LANDING GEAR.

Upper arm bearing location determination

Figure 5-5

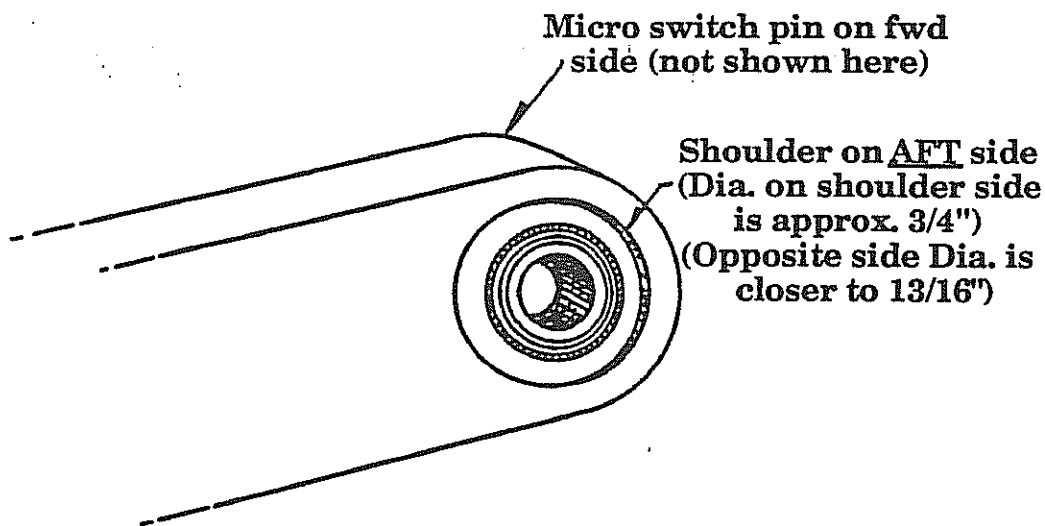

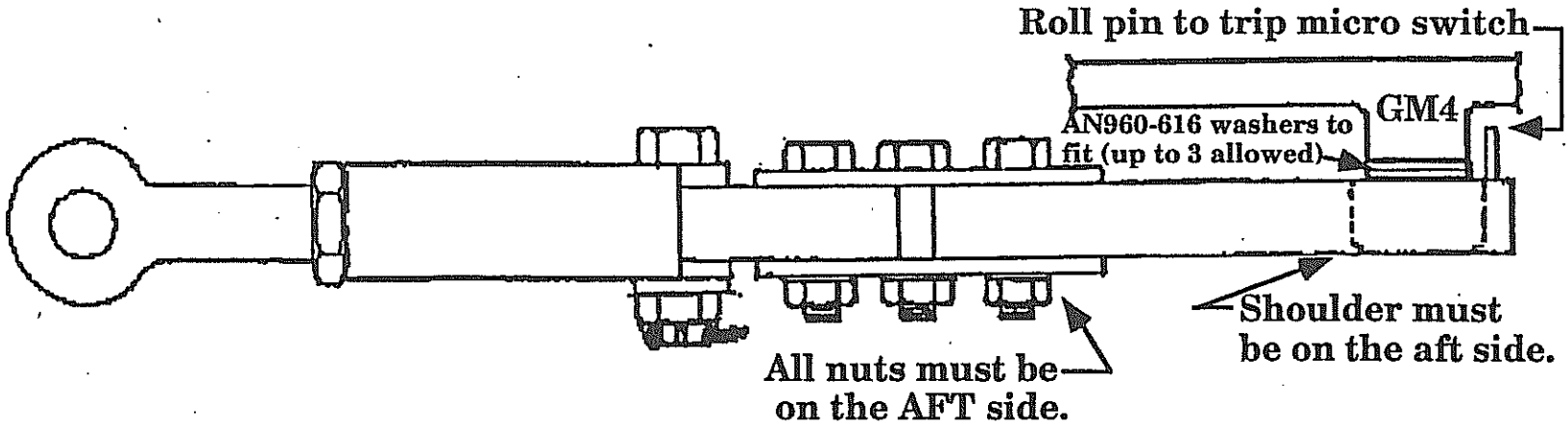
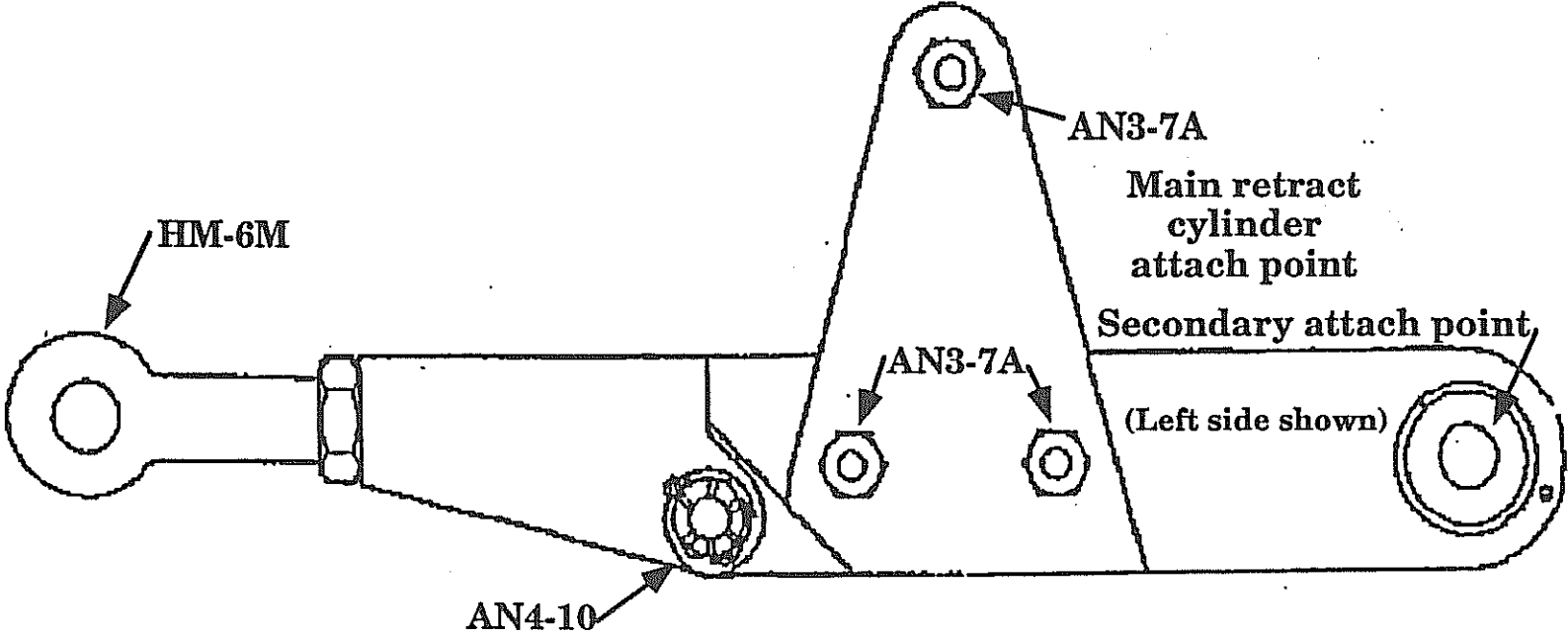

Main Gear Over Center Link Assembly
Figure 5-6



E. Main gear door cut outs

1. The main landing gear cut outs must be made before the landing gear itself can be aligned. Select the gear door template which was used during the cockpit closeout rib installation. You will note the alignment indicators from the blueprint which show the aft face of the main spar. The BL 50 position is not critical and may vary from one builder to another.

Position the gear door template on the lower wing skin and trace off its contour. The door will be cut out of the skin. It is perhaps easier to perform this task with the plane in the inverted position. Since the plane is quite easy to flip it is recommended that you do so. The traced off contour of the gear door should be made to both the inside and later the outside (bottom). The inside tracing will help assure that it's in the proper position, the bottom tracing is the one you will actually cut to.

Position the complete landing gear, with wheel, in its proper position which will simulate the retracted position. Sight along the contour to verify that the cut out is in proper position.

You can check to be sure that both top and bottom tracing are in alignment with each other by placing a bright light on one side and sighting the mutual alignment of the tracings on each side.

Main gear door cut out location

Figure 5-7

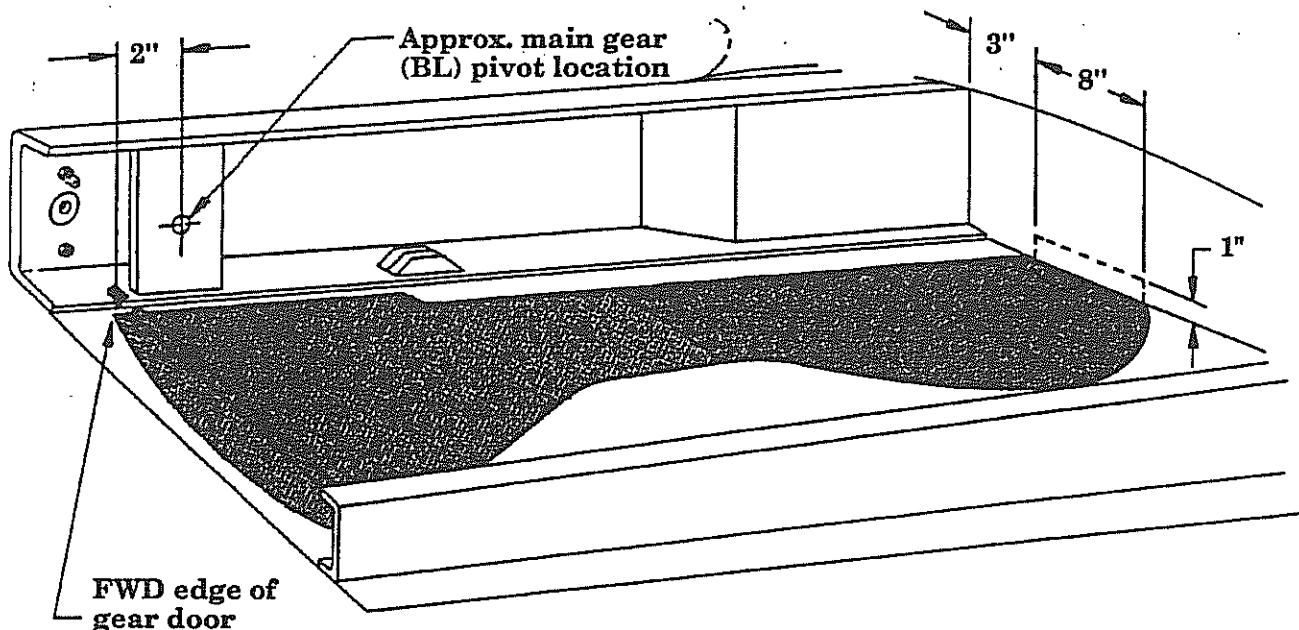

2. With the plane in the inverted position, cut the full gear door shape out of the bottom skin. (GULP!)

NOTE: The main gear door cut lines can be straight (perpendicularly) through the core but the outbd cut mark (the one along the outbd hinge line, fwd to aft) will produce a tighter fit if it is cut at the angle shown on figure 5-8.

This is quite simply done with a fine toothed blade in a sabre saw. Simply angle the sabre saw for the outbd hinge line cut to achieve the above noted angularity.

Gear door cut angles

Figure 5-8

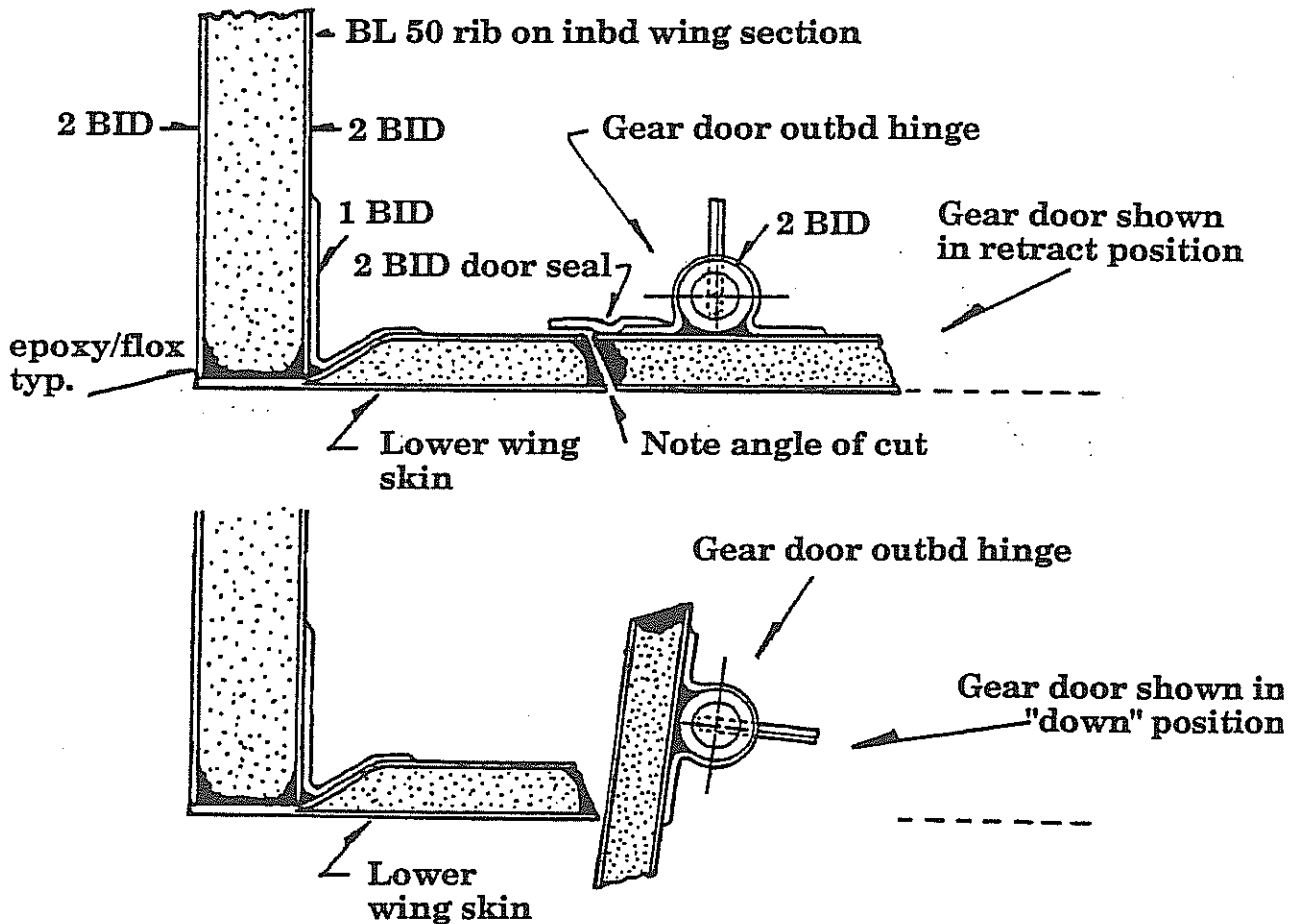

Do not make the two cuts yet which will separate the door area into its three separate pieces. This can be made after the full door piece is removed from the bottom skin.

3. With the doors cut out, return the plane to the upright position.
4. On the inside of the full gear door cut out piece, mark the location of the two separate cuts and on each side of the mark draw a line 1" away and parallel, see figure 5-9.
5. Scrape away the core material from the inside of the gear door per figure 5-9.
6. Add a 1 ply BID across this area and allow to cure.

Gear doors
Figure 5-9

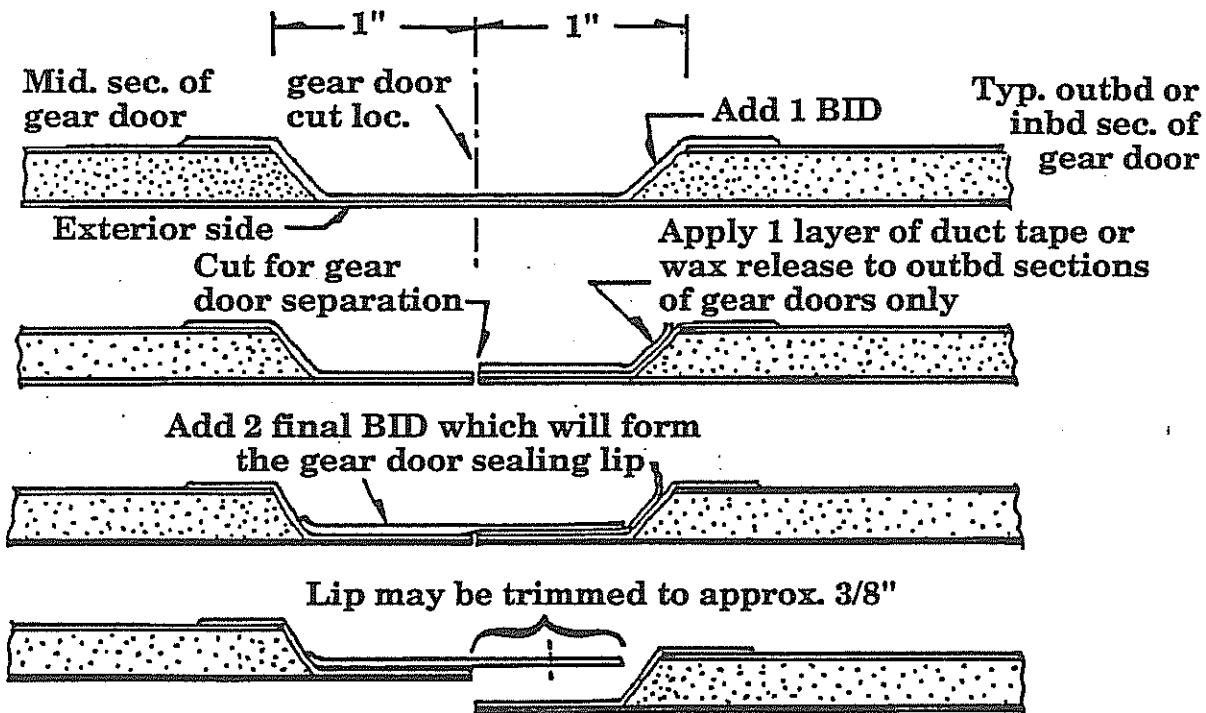

LEFT MAIN GEAR DOORS

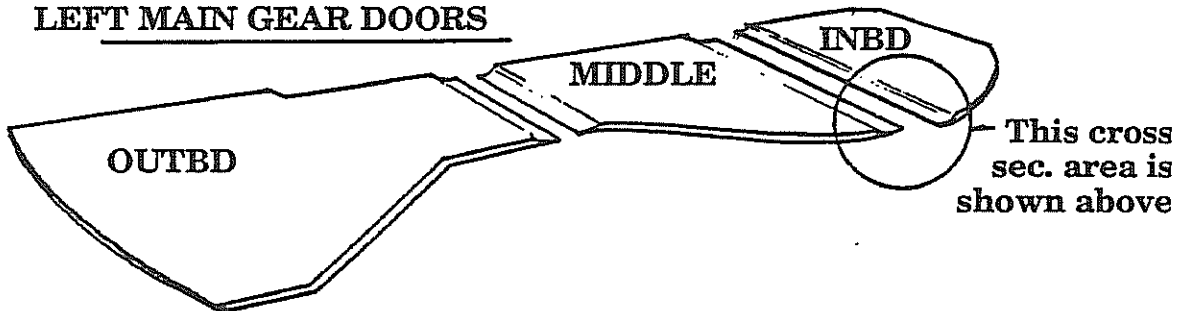

7. Next cut the doors apart on the original cut lines.
8. Cover the two outbd doors and inbd doors with duct tape along the just cut edge.
9. Add a 2 BID tape 1.5" wide across the area per figure 5-9. These tapes will permanently bond to the middle gear door and form an extending lip onto which the other two doors will seat.
10. When the 2 BID tape has cured, pop the door apart, remove the duct tape and smooth the edges. You now have a custom made lip to seal the three piece door together when the gear is retracted.
11. Now place the outbd door in position and secure with tape or similar.
12. Position the 3/8" tubing per figure 5-11 to form the hinge. This hinge is made of 3/8" x .058 outer tubing with a solid 1/4" inner rod which will extend into similar 3/8" tube sections mounted on the wing skin.
13. To properly align the 3/8" tube, position it so that there is a 1/2" distance from the edge of the gear door to the edge of the tubing (see figure 5-10 for clarity).

Positioning gear door hinge tube

Figure 5-10

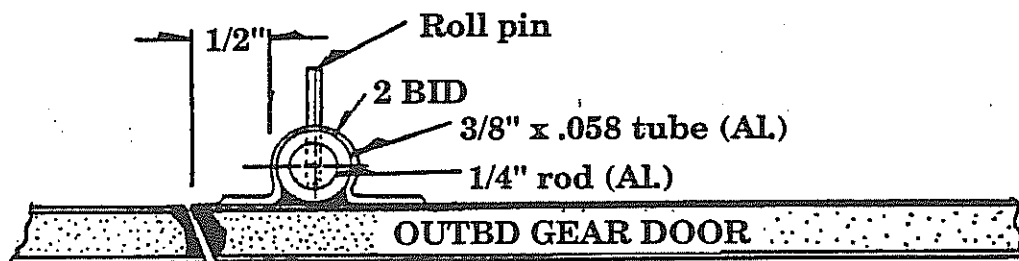

Location of gear door hinge

Figure 5-11

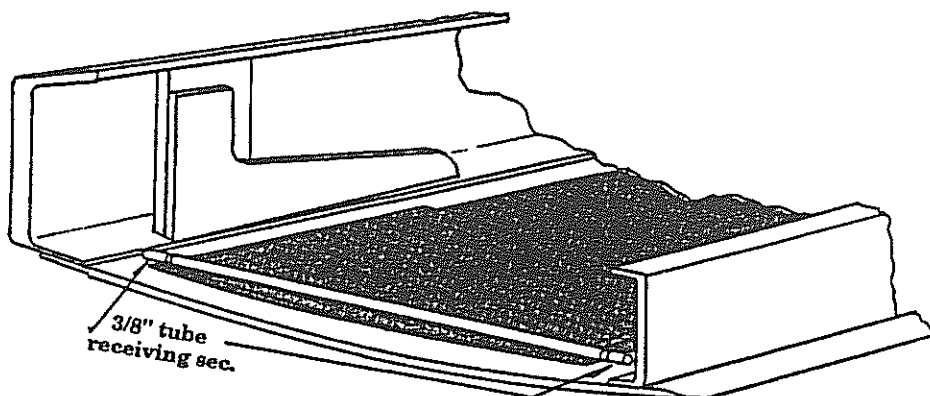

14. To check the alignments, use either instant glue or hot glue dabs at each end to temporarily secure the 3/8" tubing in position. Do the same with the small receiving 3/8" tube sections on the wing skin. Insert the 1/4" rod segments and rotate the gear door through a 110° swing check for adequate clearance.
15. When the fit is OK, flox in the area under the 3/8" tubing where the arc of the gear door creates an opening under the tube. Next add a 2 BID layup over the tube contacting the door itself with at least 1/2" of contact per side, where possible.
16. Next cut the slots into the 3/8" tubing with a Dremel or similar small cutter. This slot should extend about 3/4", see figure 5-12.

Outbd gear door hinge assembly

Figure 5-12

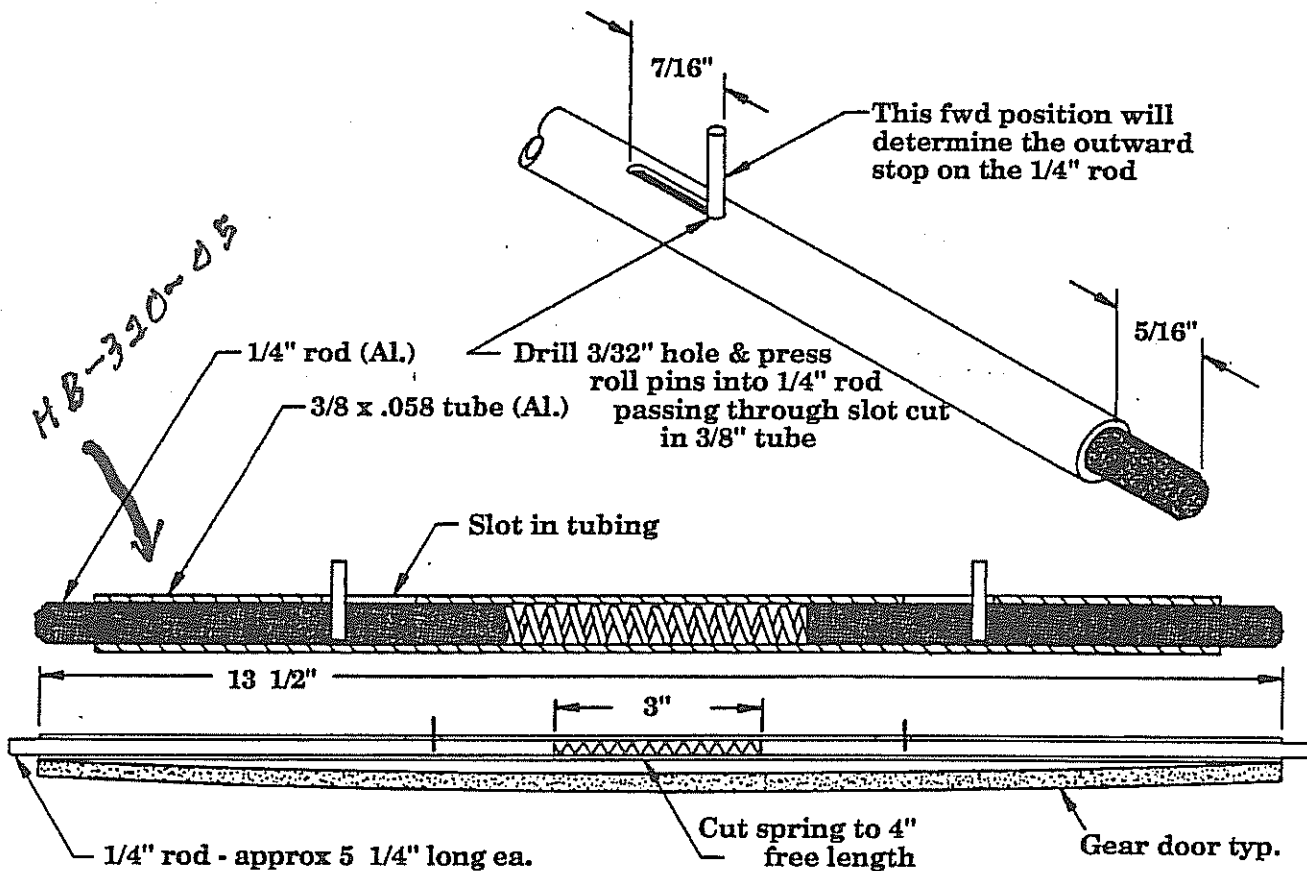

17. Drill the 1/4" rod pieces with a 3/32" drill bit to receive the 3/32" roll pin.
18. Slip the rod into the tube until the hole appears in the slot of the tubing. Then pound the roll pin into the rod through the slot.

19. Slip the ring into the other end and follow with the rod and roll pin insertion as above. Check that there is adequate spring load on the rods - it doesn't take much, just enough to keep the rods from ever vibrating out. This now forms the spring loaded hinge system which is easily removed from the bottom wing whenever necessary (primarily during wing insertion and removal to provide more working room).
20. Position the inner gear door in preparation for attaching the piano hinge.
21. This door will receive a 7" section of piano hinge as a means of attaching it to the plane. Locate this per figure 5-13.
22. Make the glass-to-glass bond area for the hinge per figure 5-13.
23. Notch the inner gear door and attach the hinge to it using four (4) 8-32 counter sunk machine screws, MS24694-S5, with nut plates. See figure 5-13.

NOTE: The hinge halves must be turned around to establish the proper "pin" orientation shown in figure 5-13.

24. Position the door with the hinge and drill for the attachment to the cockpit closeout rib where the aluminum insert was earlier positioned.
25. This half of the hinge will be pop riveted in 5 places to the closeout rib, see figure 5-13.
26. Adjust/trim for any necessary clearances. The inner door should swing 90°.



Installing gear door hinge

Figure 5-13

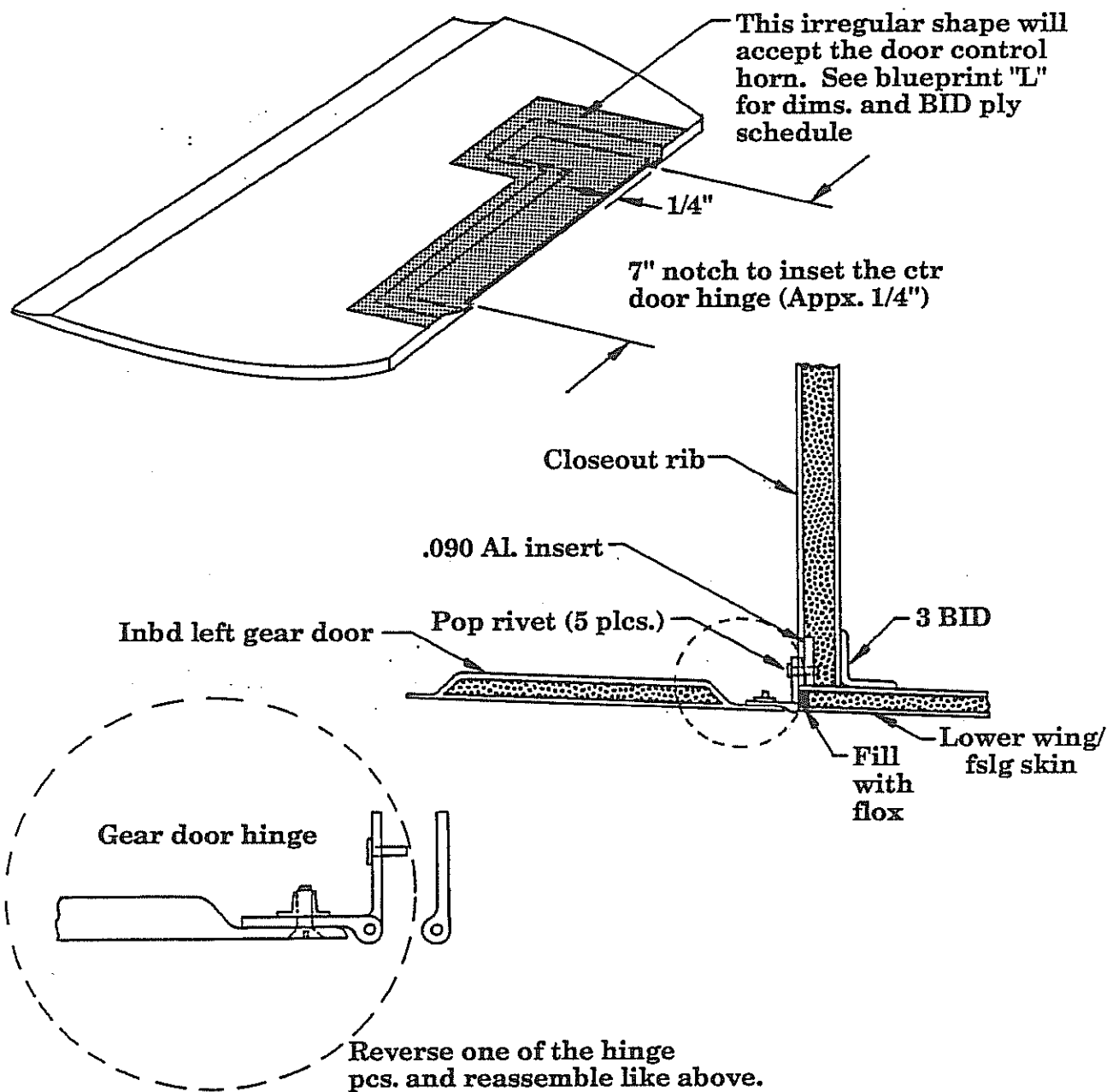

27. Next, place the gear doors in the closed position having first covered their entire edges with duct tape as a release. The doors can be duct taped from the bottom into position or held by any suitable means. They should be in a good flush fitting position.

28. Add a 3 BID tape all around the perimeter of the gear doors creating a permanent bond to the inner wing skin. The duct tape will allow a full release where contact is made to the gear doors themselves. See figure 5-14.

Forming glass lip for gear doors

Figure 5-14

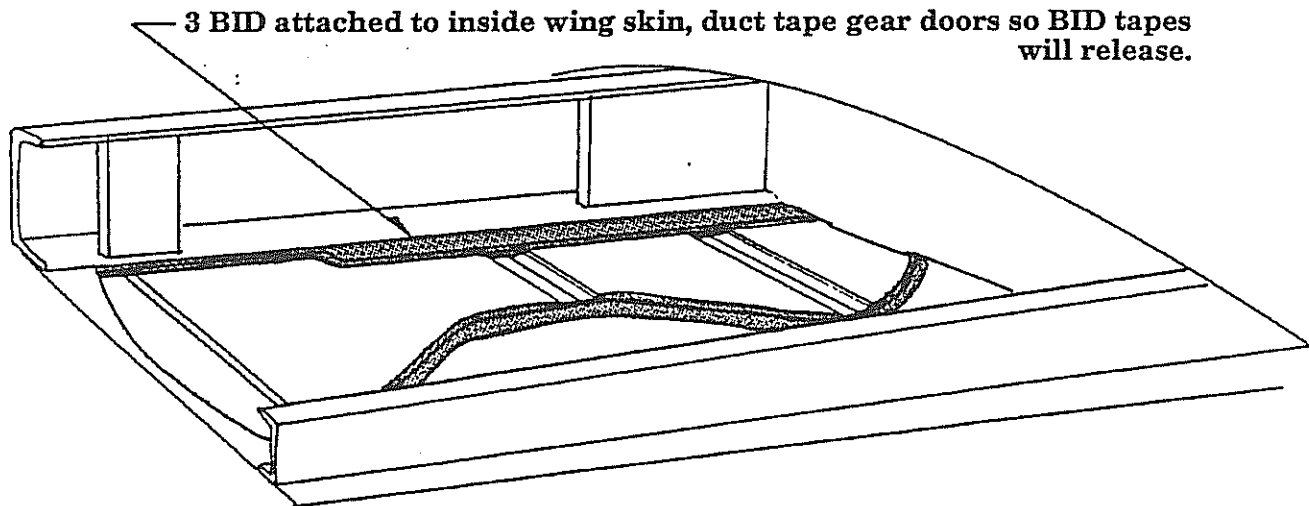

29. When cured, pop the gear doors out and finish off the glass lip which will now form the custom seal all around.

Note: The seal lip will have to be trimmed out for clearance around the over center links - just clearance where necessary. The lip need not extend more than 1/4" to 3/8" onto the gear doors.

30. Finally, finish off the gear door and wing cut out areas by digging out about 1/8" of core material and filling with flox. Sand this smooth after cure.

NOTE: The ctr section of the main gear doors will be fit later. It will bolt directly to the gear leg casting.

1. On the outer gear door, mark the position which is 6" from the hinge point. This is where the aluminum angle bracket will be potted in to receive the gear door push rod, see figure 5-15.

Potting angle bracket in main gear door

Figure 5-15

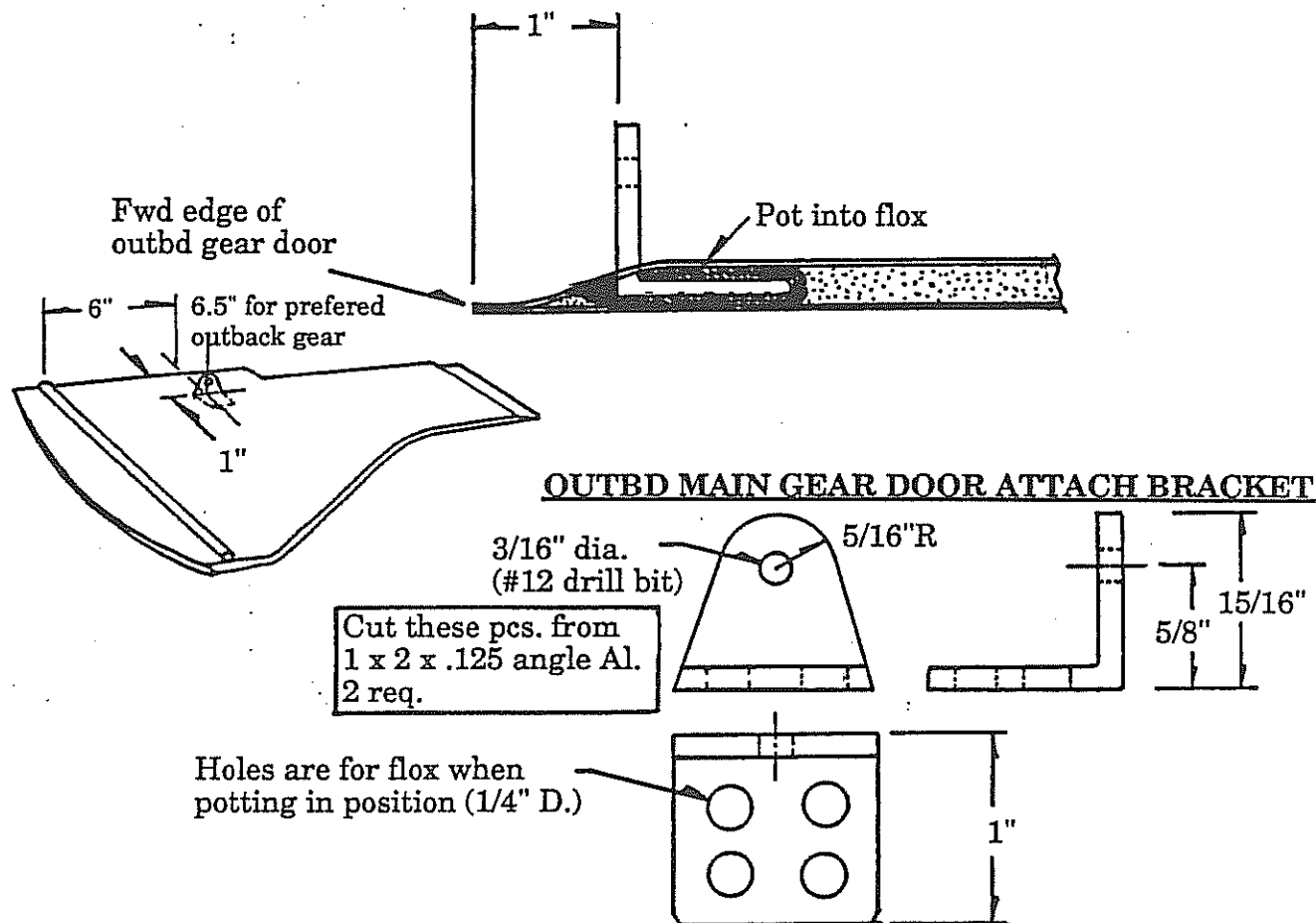

2. Make sure the push rod and bracket are per figures 5-15 and 5-16.
3. Insert the bracket by slicing the inner gear door skin and pushing the aluminum bracket into the core material area.
4. Pot the aluminum bracket into the gear door per figure 5-15.

Outboard main gear door push rods

Figure 5-16

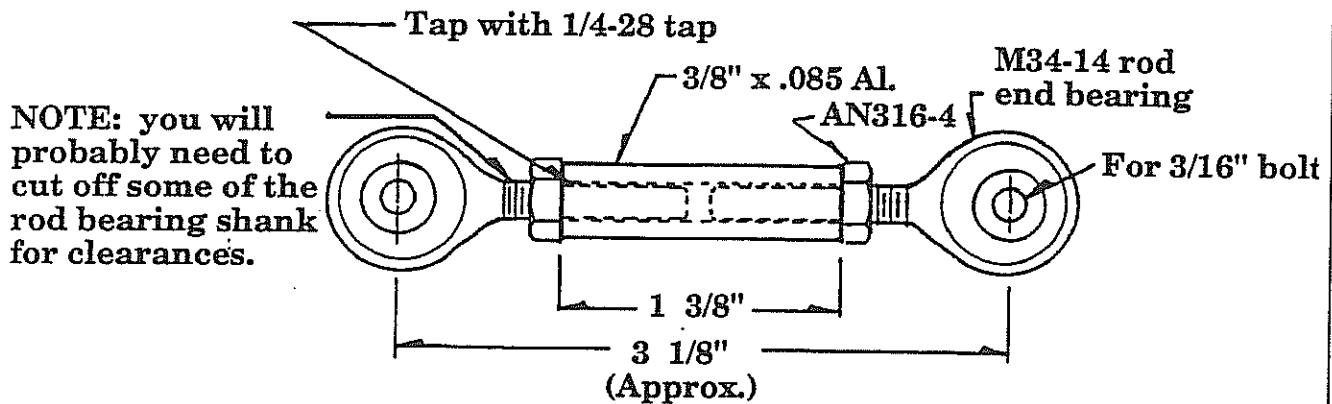

5. Mark and drill the main gear leg at the 7" position measured down from it's pivot center. Use a #12 drill bit. This is where the rod end bearing on the push rod will attach to the fwd face of the gear leg.
6. It is best to wait to adjust the gear door push rod until the upper wing skin is positioned since it will establish the actual gear stop in the retracted position and this will in turn establish the proper length adjustment of the outer gear door push rod. Later, when the plane is inverted and the inner top wing skin is mounted, you will have an easy time of adjusting this push rod and also mounting the remaining ctr door to the gear leg casting.

Drilling main gear leg for rod end bearing

Figure 5-17

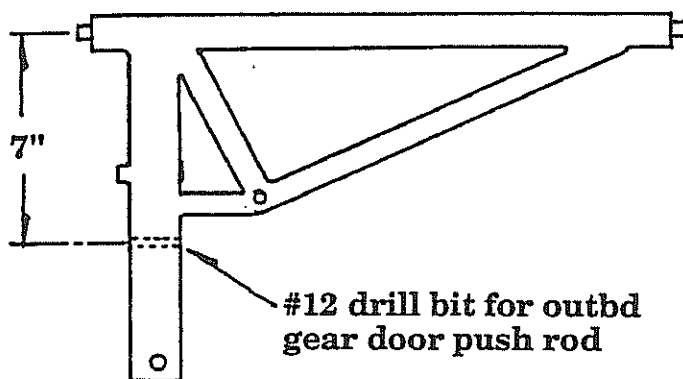

G. Main gear aft attach point

The final main landing gear alignment will be established by the positioning of this aft attach point. There will be two machine screws which will be permanent installations per aft attach point and also two AN4 bolts which will serve to hold both the aft attach plate and the outbd wing attach plate to the ctr aft spar, see figures 5-21 and 5-22.

1. First level the fslg in the upright position. Leave room for the landing gear to swing through its 90° arc from full retract to full down.
2. Position the landing gear with brake and tire assembly in place at the fwd primary attach point by inserting the pivot stub on the upper gear strut (black weldment piece) into the GM4 plate.
3. Slip the aft attach plate onto the aft end of the upper gear strut and place this end in approximate position against the ctr aft spar.

Positioning landing gear

Figure 5-18

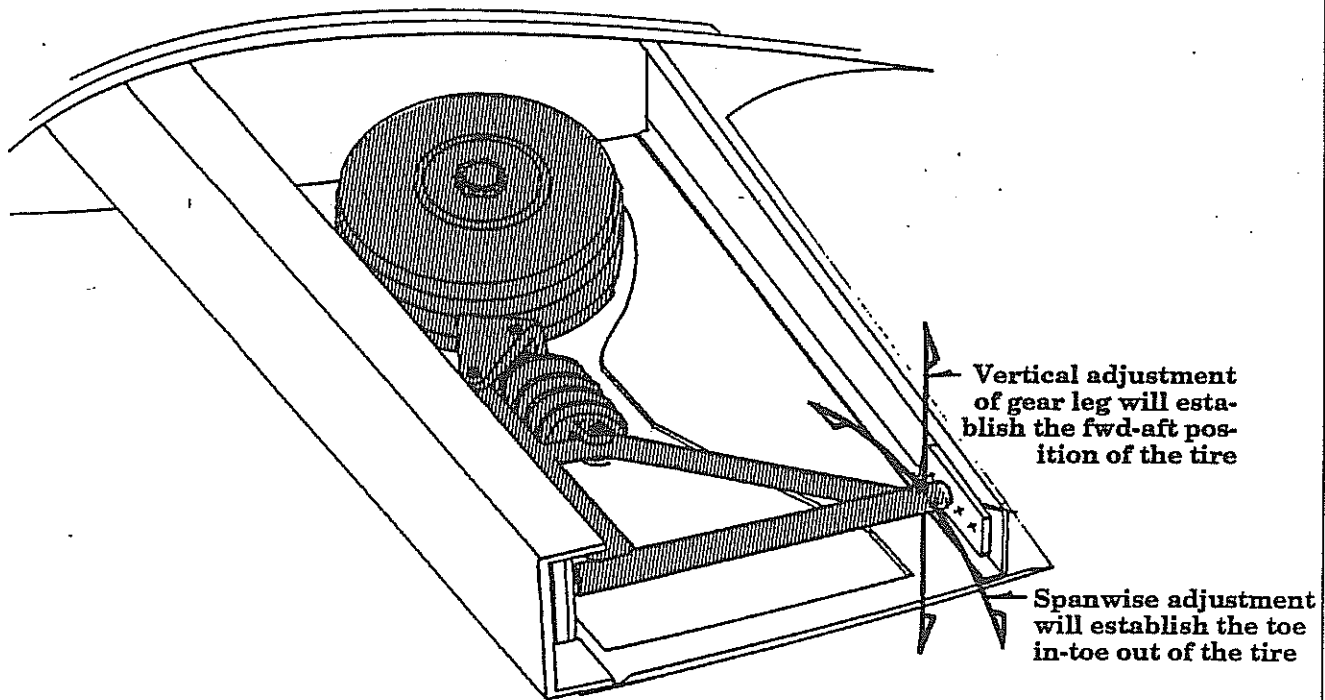

4. Using a carpenters square (the larger the better), check the alignment of the TIRE by sighting down from above while the gear is in the down position, see figure 5-19.

The carpenter's square should have one side in alignment with the ctr main spar and the other (perpendicular) side used to align with the tread of the tires. When this alignment is achieved between the tire tread and the square, the tire will be tracking parallel to the center line of the aircraft.

Use a C-clamp to lightly clamp the aft attach plate against the ctr aft spar.

Checking TIRE alignment

Figure 5-19

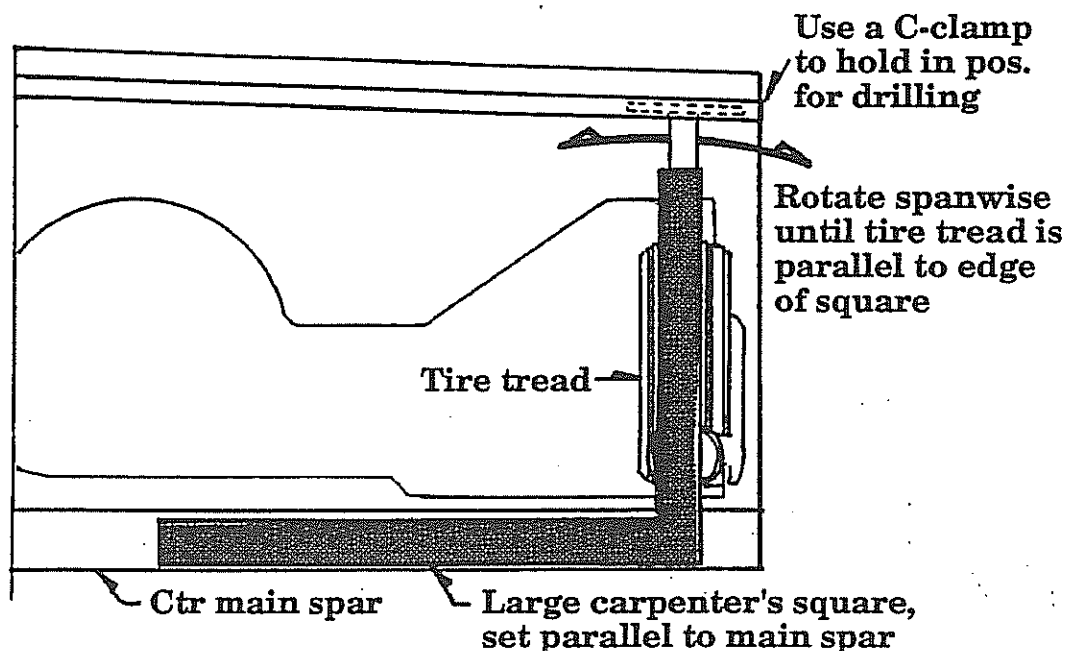

5. Now swing the gear through its 90° arc to the retract position. Since the top wing skin is not yet on, this retract position can not be found with absolute precision but it doesn't matter at this point in time.

Check that the gear has adequate clearance from the ctr main spar while in the retract position. The upper gear strut should be "relatively" parallel to the spar cap and a couple of inches aft of the spar itself.

6. Next, swing the gear back down. Sighting from the side, the gear strut should be approximately vertical, see figure 5-20. It is acceptable if the gear is swung fwd slightly but it should not be aft of vertical.

Also check this fwd to aft condition (in the down position) between the two gear struts. This can be easily accomplished by standing at the approximate position of under one wing tip spar and sighting across the plane. Note the relative angle between the two gear struts; they should be in a parallel condition.

Make any adjustments necessary to achieve these above conditions.

7. When the positioning is achieved, clamp the aft attach plates securely in preparation for drilling.

Positioning gear strut to vertical

Figure 5-20

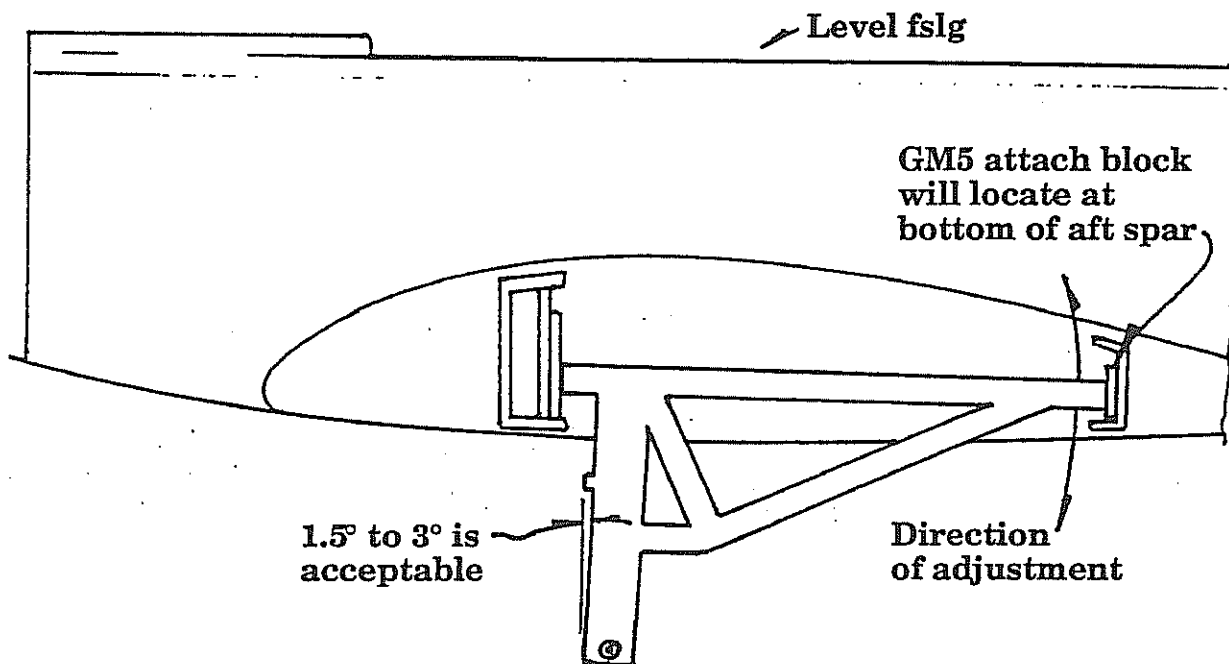

8. Using a 1/4" drill bit, mark off the first two attach locations per figure 5-22 and drill from the aft side of the ctr aft spar. Once the drill has reached the aluminum aft gear attach plate and left a mark, the attach plate may then be removed and the drilling completed in a bench which may prove to be easier. You must obviously be sure that you are drilling "straight" through the assembly or else the holes will not align properly.

There is also a 1/4" piece of aluminum inside the ctr aft spar web at this outbd gear attach position so be patient while drilling and don't allow the drill to lean back and forth while drilling or the holes will become elongated and sloppy.

These first two attach holes will be closest (on either side) to the gear strut itself. They will receive the 1/4" machine screws. They will require a 100° counter sink from the aft side of the ctr aft spar, see figure 5-22.

These machine screws should be positioned as close as possible to the gear strut in order to leave the most possible room for the second set of AN4 bolts which will follow later as the outbd wing attach bolts for the aft spar.

NOTE: Make a spot check now to verify that there will be sufficient room for the two remaining 1/4" attach bolts. They must be solidly through the aluminum web insert and GM5 gear attach plate.

Main gear aft attach plate

Figure 5-21

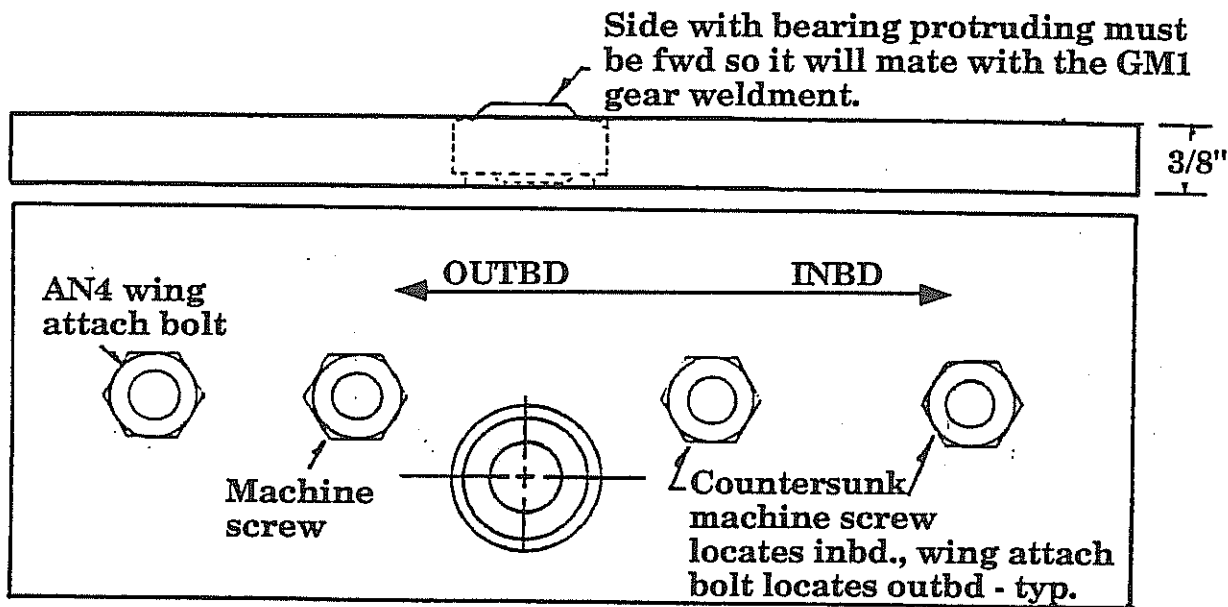

NOTE: GM5 plate orientation is such that the pivot bearing will mount outbd and to the bottom of the plate. The bearing block shoulder should be to the aft side.

NOTE: The four 1/4" bolt attach points are not critical regarding location.

9. With the first attach holes drilled and countersunk, the machine screws may be bolted in position thus locking the gear to the wing.

Main gear aft attach
 (top view, left side)
 Figure 5-22

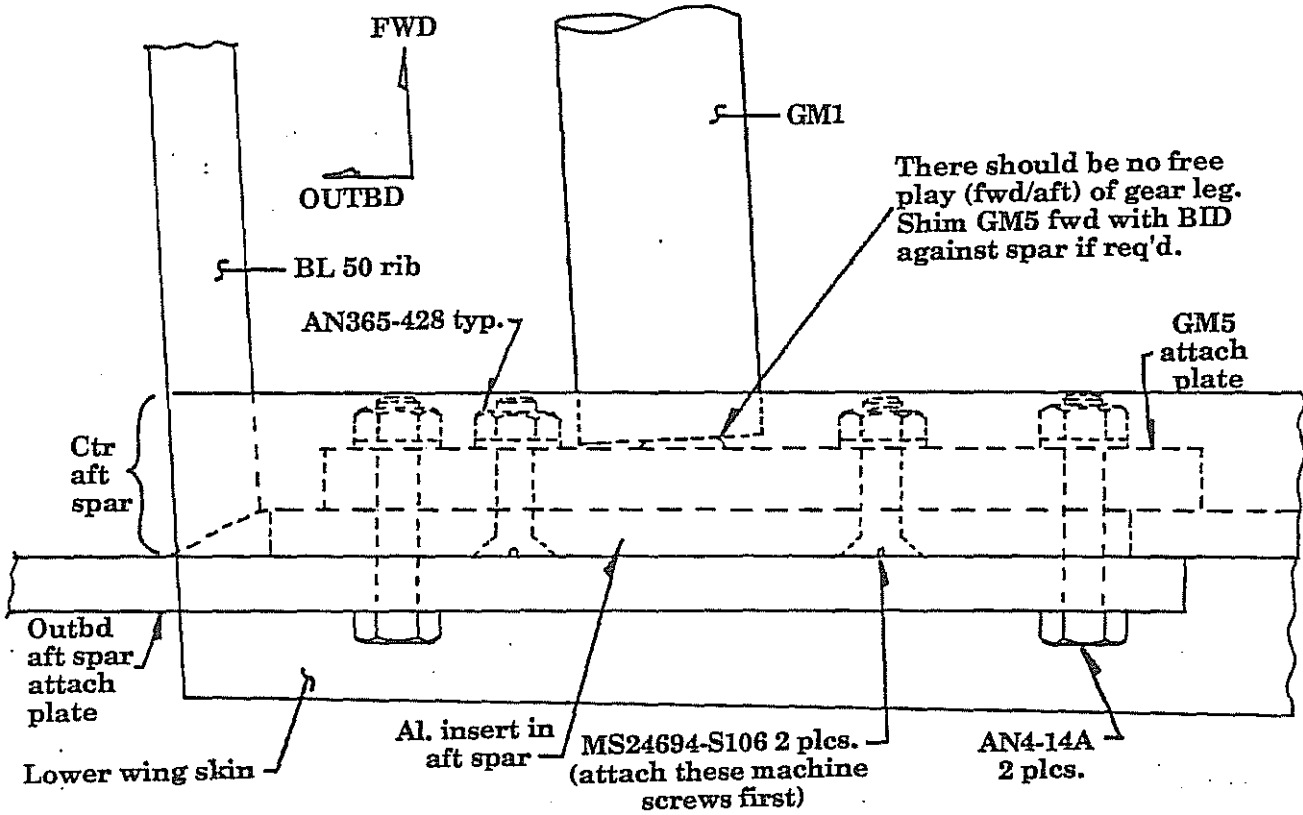

H. Main gear over center links

1. With the gear in position, assemble and attach the over center links using the 3/8" bolts (see figure 5-6 and 5-2).

Be absolutely sure that you have the correct link assembly on the correct side (refer back to over center link assembly drawing). The pin must be on the FWD face of the upper link and the shoulder of the bearing hole must be on the AFT face of the link for proper operation. The pin will later be adjusted to trip the micro switch to indicate "down and locked".

Check the clearances by cycling the gear up and down several times by hand. Be sure that the slight rocking motion allowed for on the over center link assemblies is within limits by not interfering with the GM4 attach plate, see figure 5-24.

2. Adjust the lower rod end on the links until the tire/wheel is in the vertical position relative to the ground. Tighten the check nut against the rod end bearing. Do not sight vertically against the lower wing as a reference since it has a three degree dihedral in it.
3. Install the overcenter torsion springs. These maintain pressure on the links and assist in a free fall mode.

Overcenter link springs

Figure 5-22.1

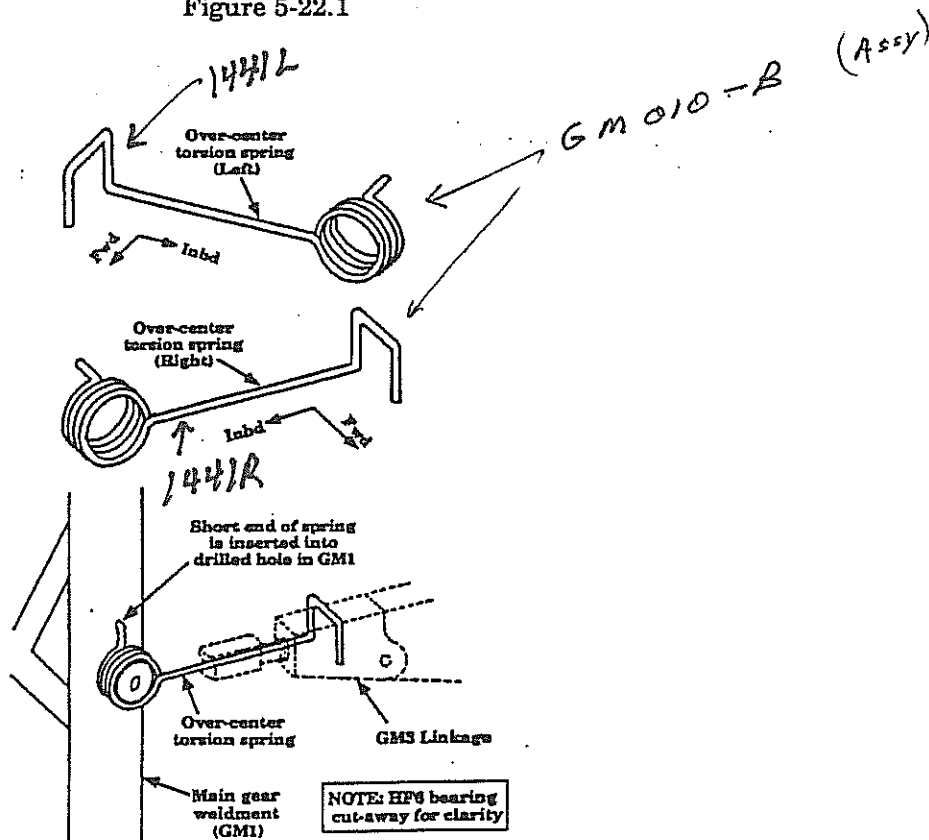

Springs Attach to Gear Weldment

Figure 5-22.2

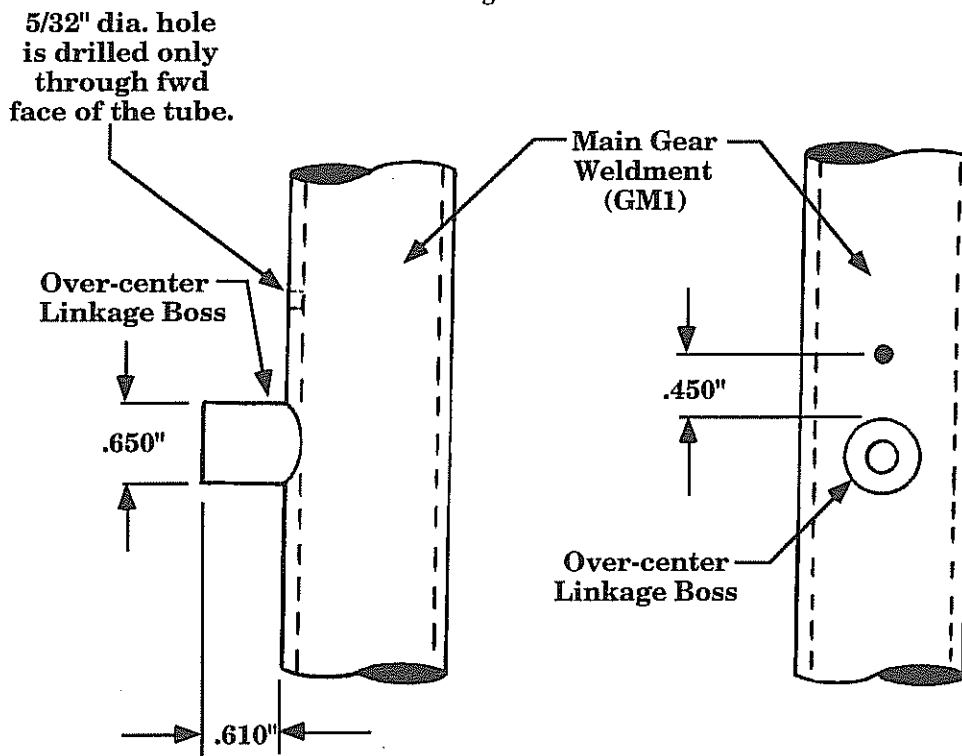

Spring/Gear Weldment x/c

Figure 5-22.3

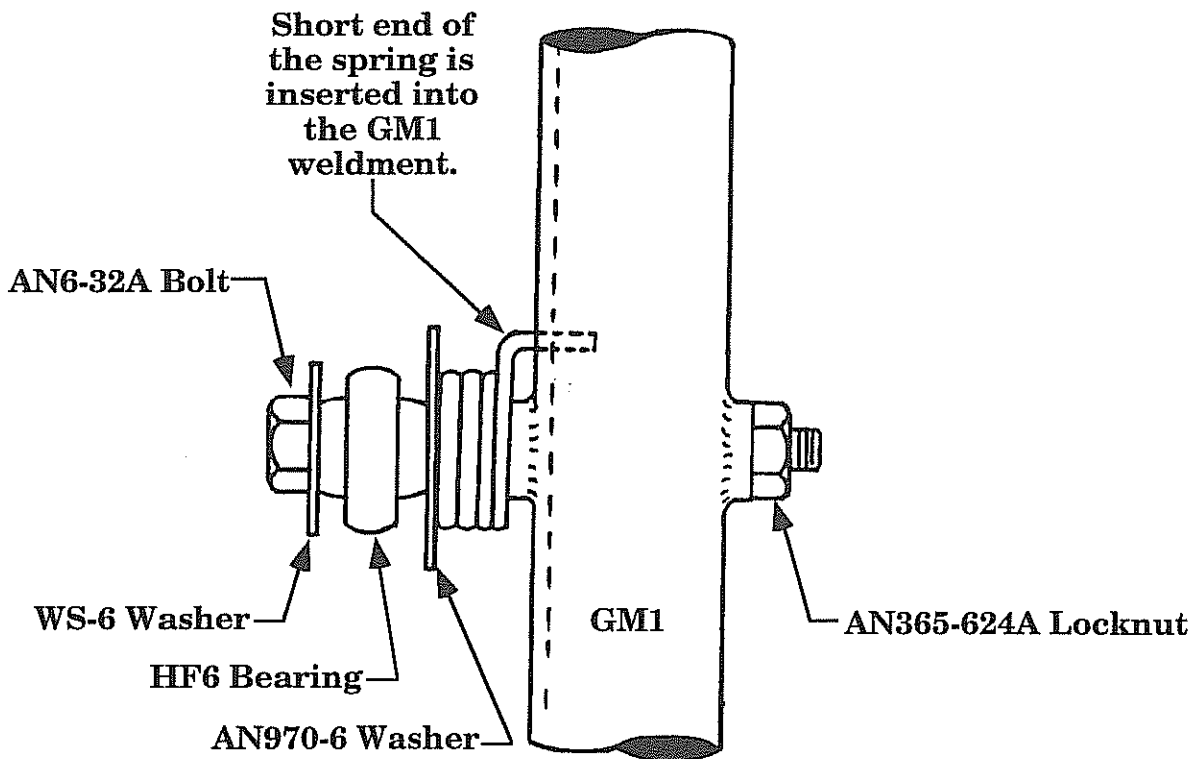



4. Locate and center punch a spot on the gear weldment per Figure 5-22.2 and drill through only the fwd wall of the tube with a 5/32" bit. The hole position is somewhat critical so measure accurately.
5. As a chafe guard, cut and install a 1/2" length of heat shrink tubing over the boss on the gear. Use a heat gun to shrink the tubing until it's tight on the boss.
6. Slide the torsion spring onto the weldment boss with the short end of the spring in the 5/32" hole. The other end will be spring loaded over the lower end of the overcenter link assembly. The WS-6 and AN970-6 washers, also secure the position on the boss.

Spring Attach to Overcenter Links

Figure 5-22.4

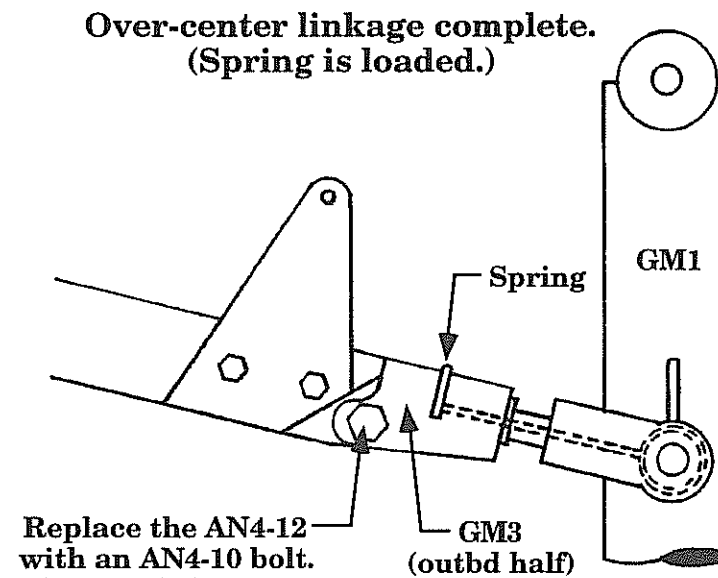
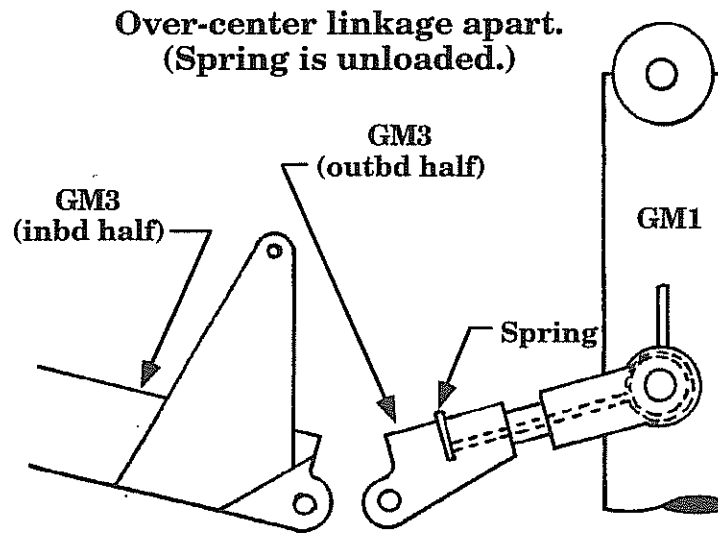

Replace the AN4-12
with an AN4-10 bolt.
Put an AN960-10
washer under the
castle nut.



7. Secure the outbd half of the GM3 to the weldment boss with a WS-6 washer on each side of the bearing. Tighten the AN6-32A bolt.
8. Hook the long end of the torsion spring over the outbd half of the GM3. Connect the halves of the GM3 assembly with the AN4-10 bolt. Be sure that there is a little lube in the swivel area of the GM3 assembly and that there is no binding.

Attaching springs to gear leg

Figure 5-23

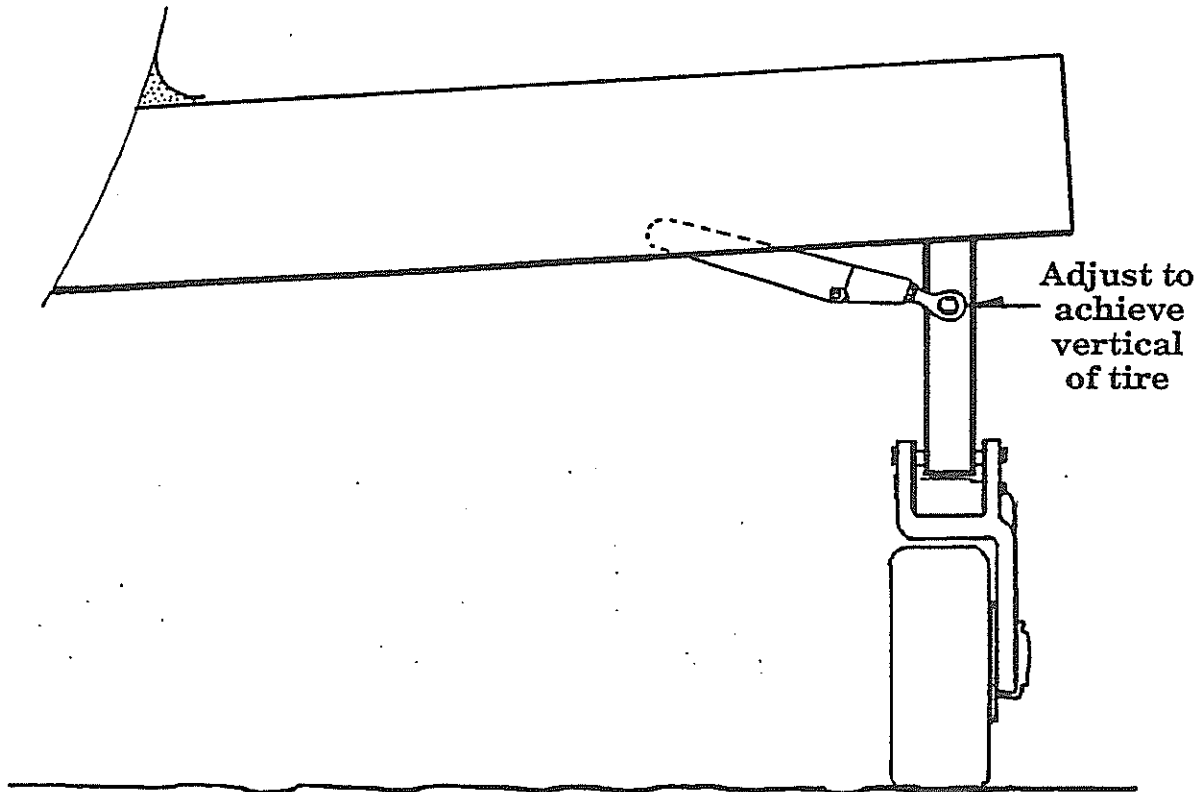

Strut clearance and travel

Figure 5-24

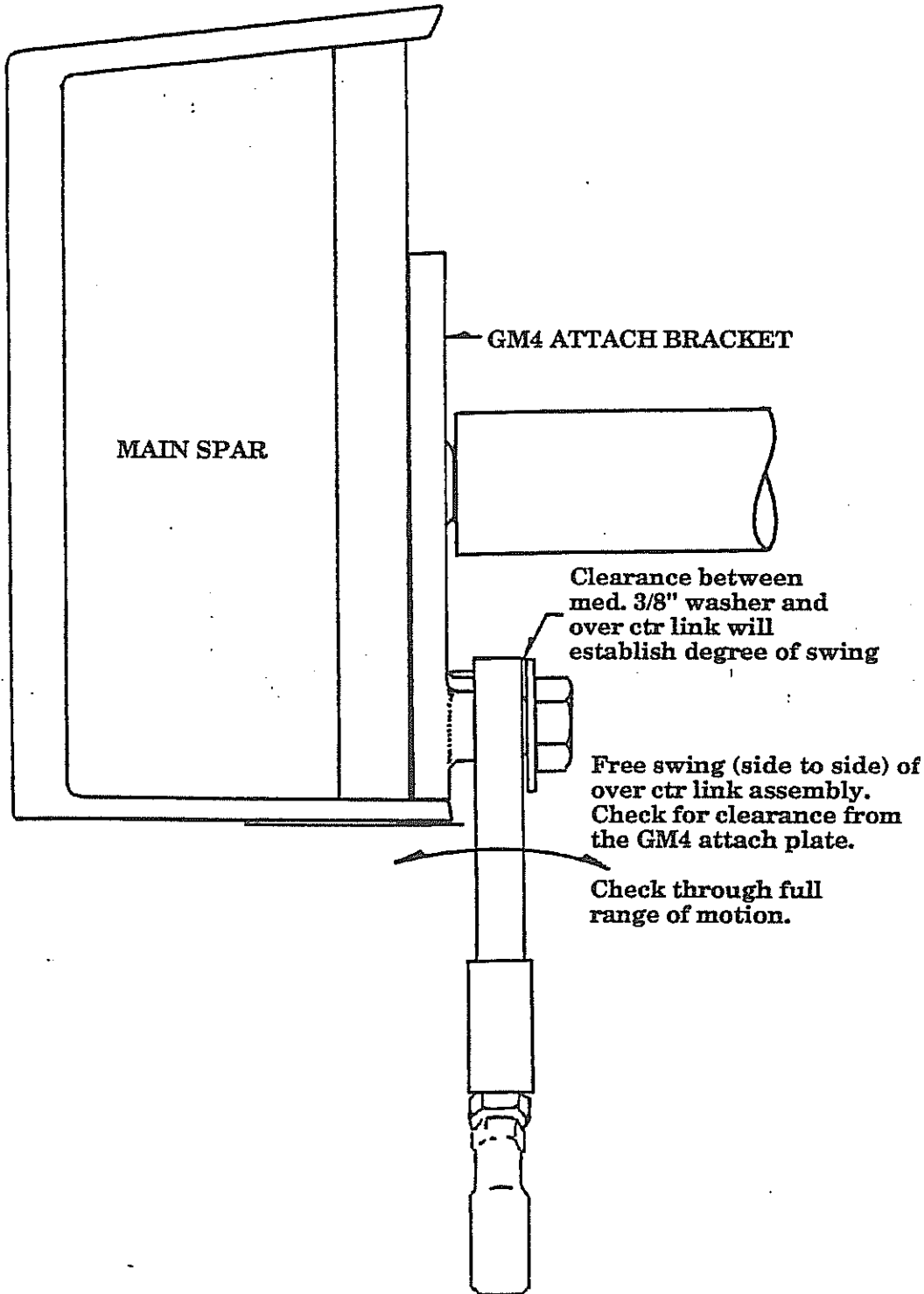

NOSE GEAR ASSEMBLY BREAKDOWN

Figure 5-25

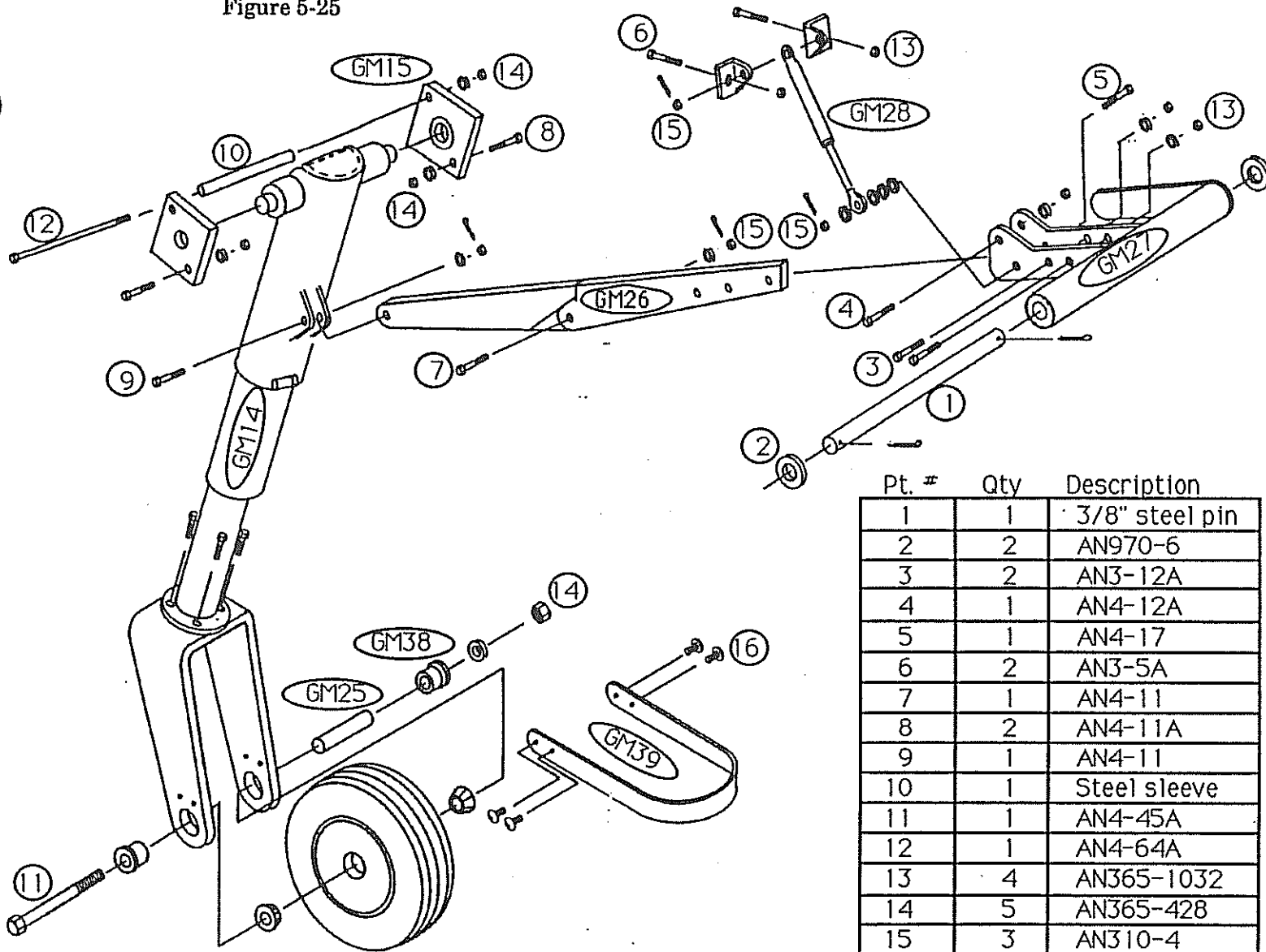

Pt. #	Qty	Description
1	1	3/8" steel pin
2	2	AN970-6
3	2	AN3-12A
4	1	AN4-12A
5	1	AN4-17
6	2	AN3-5A
7	1	AN4-11
8	2	AN4-11A
9	1	AN4-11
10	1	Steel sleeve
11	1	AN4-45A
12	1	AN4-64A
13	4	AN365-1032
14	5	AN365-428
15	3	AN310-4
16	4	AN526-1032R6

Nose gear assembly drawing
Figure 5-25

Nose gear assembly / engine mount

This section will contain assembly information for the model 320 nose gear and engine mount installation.

I. Nose gear strut assembly

1. The Lancair 320 nose gear strut is the air / oleo type and will arrive fully charged with all kits. The internal pressure setting may be adjusted depending on type of prop used (and the resultant airframe weight) etc. but we suggest that no changes be made until the plane has been taxi run for a few hours. The strut will likely remain in its fully extended position during airframe assembly, even after the engine has been installed. This will result in a pronounced nose up ground attitude. With the weight of the constant speed propeller (about 58 lbs.), along with a "break in" of the internal seals, the strut should end up compressing about 3/4" - 1" when in the static load condition.
2. This strut has no scissors links and is fully internally shimmy dampening.

WARNING: This strut assembly must not be taken apart. It is considered to be NON field repairable. Should adjustments other than the air charge be deemed necessary, it should be returned either to Neico Aviation or directly to Esco, its manufacturer. Any disassembly of the shimmy dampening chamber at the bottom will ruin its internal integrity and allow the possibility of a shimmy condition, thus the plane must not be flown until Esco has re-assembled the unit. There should be no reason to disassemble this unit.

3. Select the nose wheel halves and their three bolts along with the two timken bearings. Install the inner tube into the tire by first applying just a small bit of air into the tube. Just add enough to get the wrinkles out of the tube. Too much air will make assembly difficult.
4. Push one side of the wheel through the tire / tube.
5. In order to prevent the chance of getting a pinched tube during assembly of the second wheel half, use a piece of thin cardboard (cereal box type) as a liner. This piece should be about 3" wide and long enough to go around the interior of the wheel, between it and the tube. See figure 5-26.
6. With the cardboard insert in position, the second half of the wheel can be pushed into position with it inside of the cardboard piece that is sticking up. This will prevent a pinched tube.

Wheel & tire Assembly

Figure 5-26

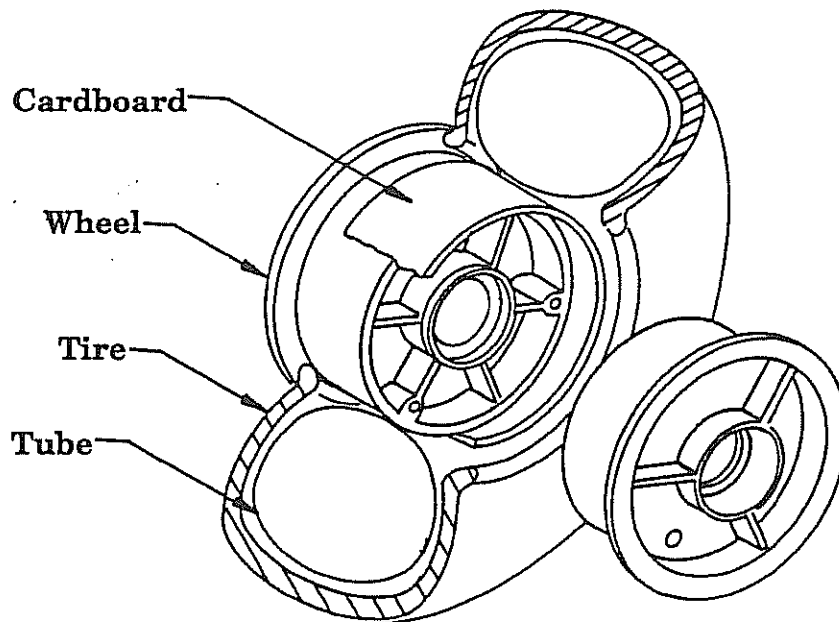

7. Install the three nose wheel connecting bolts and tighten them securely. Then inflate the tire to 35 lbs.
8. Slip the timken bearings into position on the wheel and insert the steel tubular nose gear axle, GM25. The bearing must have axle grease packing prior to assembly.
9. Position the above assembly into the fork and insert the two axle plugs, GM38. These plugs will slip over the axle.
10. Insert the AN4 bolt and tighten it up until the wheel drag becomes such that with a good spin on the tire, not more than one free revolution results. (However, you should first install the tire strap before tightening the through bolt, see step 11 since it will align the two axle plugs and prevent them from spinning.)
11. Place a small dab of paint or equiv. over the nut and end of bolt. This provides a visual check to verify that the nut is not loosening during flight operations.

WARNING: The nose gear wheel must have sufficient friction (as described above in step 10) to prevent possible shimmy. Failure to keep the wheel properly snugged could result in shimmy. This must be checked on a regular basis by having someone push the tail down momentarily while you check the rotational resistance on the wheel.

12. Install the tire strap that fits around the back of the nose gear tire and attaches to the fork on each side. Note that this fork is the means by which the GM38 axle plug is prevented from rotating. Align the flat spot on the side of the GM38 axle plug with the tire strap.

This strap will help guide the wheel into the nose gear tunnel in the unlikely event of a turned wheel after lift off.



J. Engine mount / nose gear attach & align

1. The firewall has been marked for engine mount primary attach points (the 4 perimeter points). Note that there are two additional attach points (one on each side of the tunnel), see figure 5-27.
2. It is best to first drill only 1/8" pilot holes for the primary mount attach holes in the firewall. Use the mount itself as a final hole position check. The holes could easily be off just a little since, even with stress relieving, some "pull" will result in the engine mounts. Do not force the mount to attempt to align with the markings, simply average the differences and drill accordingly. The holes should not be off by more than 1/4" in any plane or direction though.

The mount may be bolted into temporary position. The final installation will require the fiberfrax and stainless over the firewall before the mount is attached permanently. The fwd deck should be clecoed into position and the 2 BID attach tapes applied such that they are bonded to the firewall and "released" from the fwd deck lip. Use duct tape or plastic tape as a release. You will thus have a mating flange bonded to the firewall which will allow you to proceed ahead and add the fiberfrax, stainless and mount. Later the fwd deck can be permanently attached using structural adhesive along the flange on the firewall. The fwd deck should not be bonded on until the wiring is completed, etc. Also, you may wish to make the fwd deck removable as is outlined in chapter 11.

3. Trim and fit the fiberfrax and stainless steel. These materials can be mounted using high temp. silicone squeegeed on between layers.

NOTE: Save the left over pieces, you'll need them in chapter 21 for shielding in the nose gear tunnel.

4. Position the nose gear assembly on the mount using the GM5 attach plates. Clamp into temporary position with small C-clamps to make ready for final adjustments.

Firewall layout
Figure 5-27

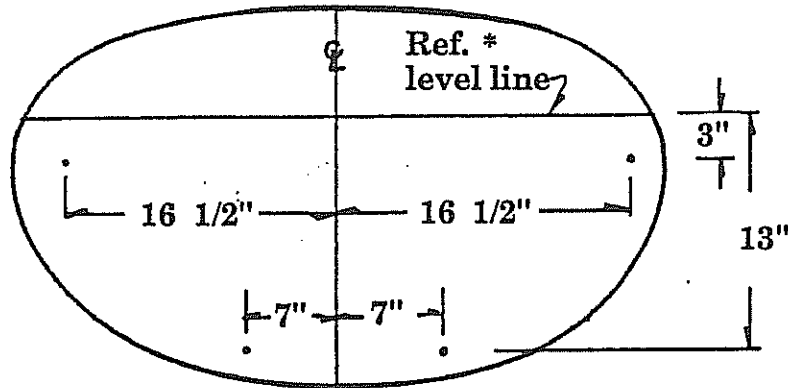

FIREWALL DETAIL
CROSS SECTIONAL VIEW

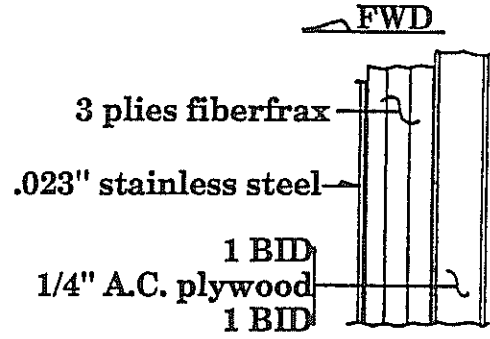

***NOTE:** Level line is for reference purposes only.
It does not align with longerons, etc.

Nose gear / engine mount
Figure 5-28

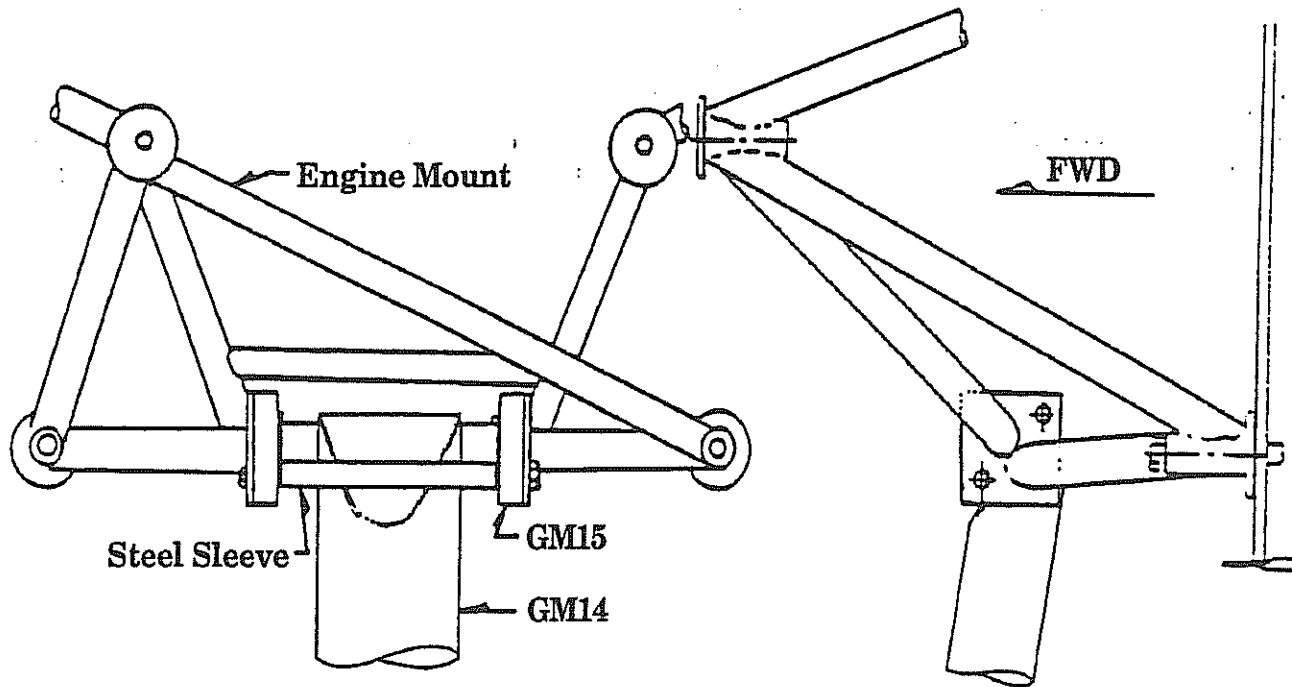

NOTE: There are two directions which affect the positioning of the nose gear for proper alignment on the engine mount.

5. FWD to aft adjustment (see figure 5-29). This will align primarily the side to side positioning of the assembly for proper retraction into the nose gear tunnel. It should be set with the gear held up into the tunnel in the retracted position. Adjust it until the wheel is centered in the tunnel. If there were to be any direction off at center preferred, it would be to the left (or pilot's side) since that will move it farther away from the gear door and its hinge.

Nose gear adjustment
(As it relates to proper alignment in the tunnel)
Figure 5-29

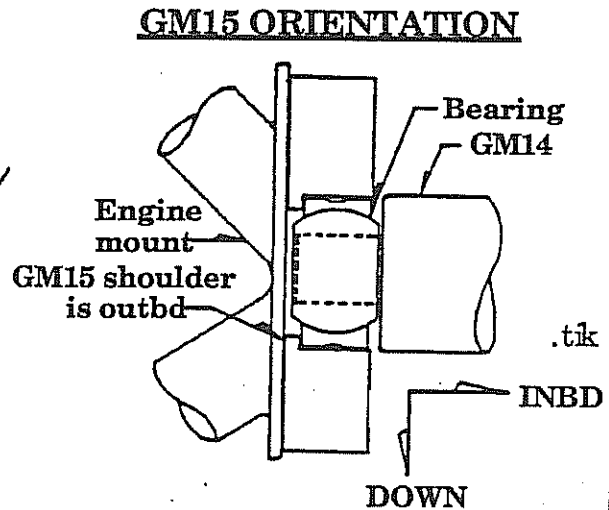
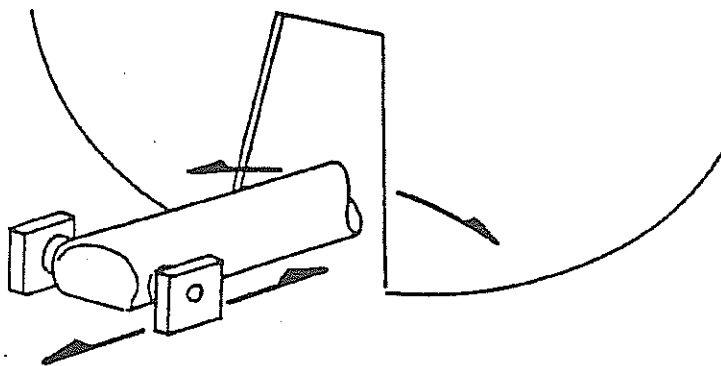

- a. When installing the GM15 attach blocks onto the nose gear strut (GM14) note per figure 5-30 that the shoulder portion of that attach block should be toward the outside of the strut and against the engine mount.

(Also, early model 320 struts will require washers as shims to achieve a snug fit into and between the engine mount pick up pads. Use the supplied AN960 washers. These should be slid onto the GM14 pivot ends prior to installing the GM15 bearing blocks on the strut for a snug fit into the engine mount.

WARNING: No more than two washers per side can be used as shims. Additional spacing could create excessive bending loads and possible failure.

- b. Also, when first clamping the nose strut into approximate position on the engine mount, verify that the AN4 through bolt and its steel sleeve will have adequate clearance room across the front of this assembly. Slight adjustments of GM15 positioning on the engine mount pads can affect this clearance so do make a visual check before drilling for the attach bolt holes.

c. If you were to drill the attachment holes in error, you will have one additional chance to get it right since the GM15 bearing blocks can be rotated 90° thus providing new, un-drilled surfaces for attachment.

Installing GM attach blocks onto the nose gear strut

Figure 5-30

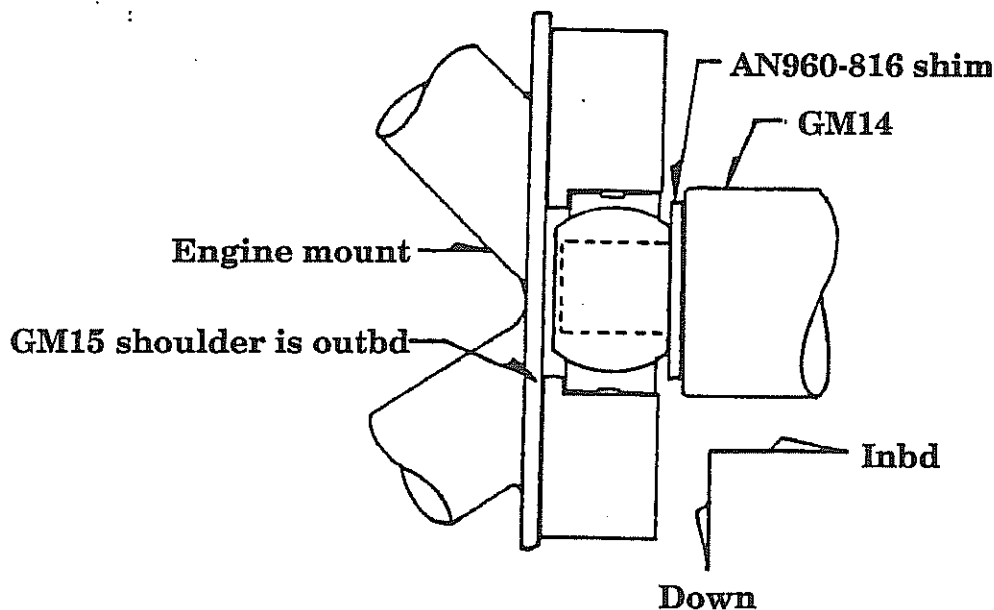

Note: Late model Lancair 320's are equipped with "ESCO" manufactured nose gear air/oleo strut assemblies. These struts do not require the above described AN960 washers as shims.

6. Vertical adjustments, see figure 5-31.
This will align the vertical (side to side) positioning of the assembly while in the DOWN position. This should be checked with a level while the fuselage is in a level position. To make this check best, hold the gear strut in a down position that is true vertical. This will not be to the fully extended position which is approximately 4° farther fwd.

Nose gear adjustment
(as it relates to vertical alignment)
Figure 5-31

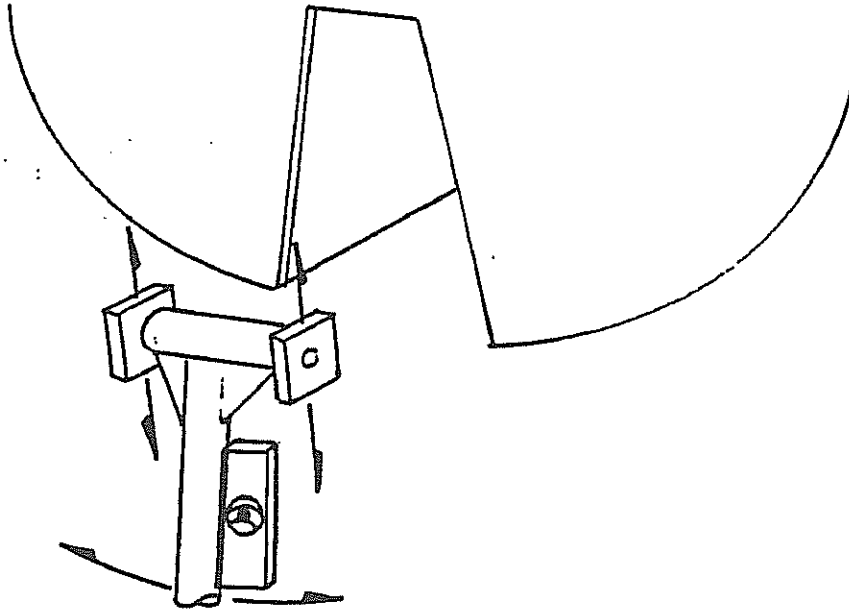

Each of these directions of adjustment will have a cumulative effect on the other. It is therefore necessary to make several small adjustments, checking the total effect after each adjustment.

Alignments are best made by first clamping the GM15 plates with a small C-clamp and then gently tapping these plates with a small hammer in the desired direction of adjustment. Check the effect of the movement after each tap.

Proper alignment will be achieved when the strut is in a true vertical alignment and the assembly swings into the nose gear tunnel with equal clearances on each side.

7. With the proper alignment achieved, tighten the clamps and drill through for the AN4 attach bolts.

8. Note that the engine mount must already be pilot drilled to a 3/16" diameter. The final adjustment location of the GM15 blocks must also be such that these pilot holes are solidly aligned with the GM15. It is best to first drill on through with a 3/16" or #12 bit, then follow with the final .250" drill bit.

9. The forward two attach bolt holes will be secured with one long attach bolt that spans across the mount pick up points. A steel sleeve is supplied with the engine mount which must be installed between the two GM15 plates. Then slip the long AN4 bolt through the entire assembly and tighten down. The sleeve will require some filing to fit. The final fit must be tight between the two GM15's.
10. The two aft bolts are small AN4's that individually hold each GM15. See figure 5-28.



K. Nose gear drag link installation

1. Assemble the nose gear drag link per figure 5-32. Once again, it is important to have the bolts arranged properly for adequate clearances during retraction.
2. Attach the lower link section to the gear strut with the AN4 bolt (#6). The location of the attachment holes in the tunnel is shown in figure 5-33 but this is a good way to check and verify through a second means that the locations are indeed accurate for your installation since minor differences can result due to a variety of builder variations.
3. With the fuselage level, the proper position for the nose gear assembly will be achieved when the strut assembly is in a 4° positive angle, i.e., the base of the strut is fwd of the top and a 4° angle off of vertical is realized along the strut's centerline.
4. With the gear strut properly aligned and held in position at the approx. 4° position, place and mark the nose gear tunnel for the location of the 3/8" steel pivot pin that inserts through the GM27 weldment and attaches into the tunnel walls. Use the drag link assembly to locate this point by simply swinging it up into the tunnel and checking against attachment marks that should be according to the location shown in figure 5-33. Also see figure 5-35.

WARNING: Be sure to verify that the location of the 3/8" pin is indeed into the central portion of the phenolic. There should be at least 3/4" of phenolic all around the pivot hole. Failure to secure the pivot pin properly into the phenolic will result in gear failure.

5. You'll have to use an angle head drill to drill the first hole through one of the tunnel sides for this 3/8" pin. It is best to use a slightly smaller size drill bit and use a .375" reamer as a final bit, this will leave a nice, snug fitting hole. A standard 3/8" drill bit can however be used with satisfactory results, but be careful to not wobble the bit back and forth while drilling.
6. With one side of the tunnel drilled, slide the 3/8" steel pin through and level it across the tunnel interior. (The fuselage must also be levelled at this time.) When levelled, mark and drill the other side.
7. Cut the steel rod to length and drill the small holes for the cotter pins at each end, see figure 5-35. Use AN970-6 area washers under the cotter pins, against the outbd tunnel walls.



NOSE GEAR DRAG LINK ASSEMBLY

Figure 5-32

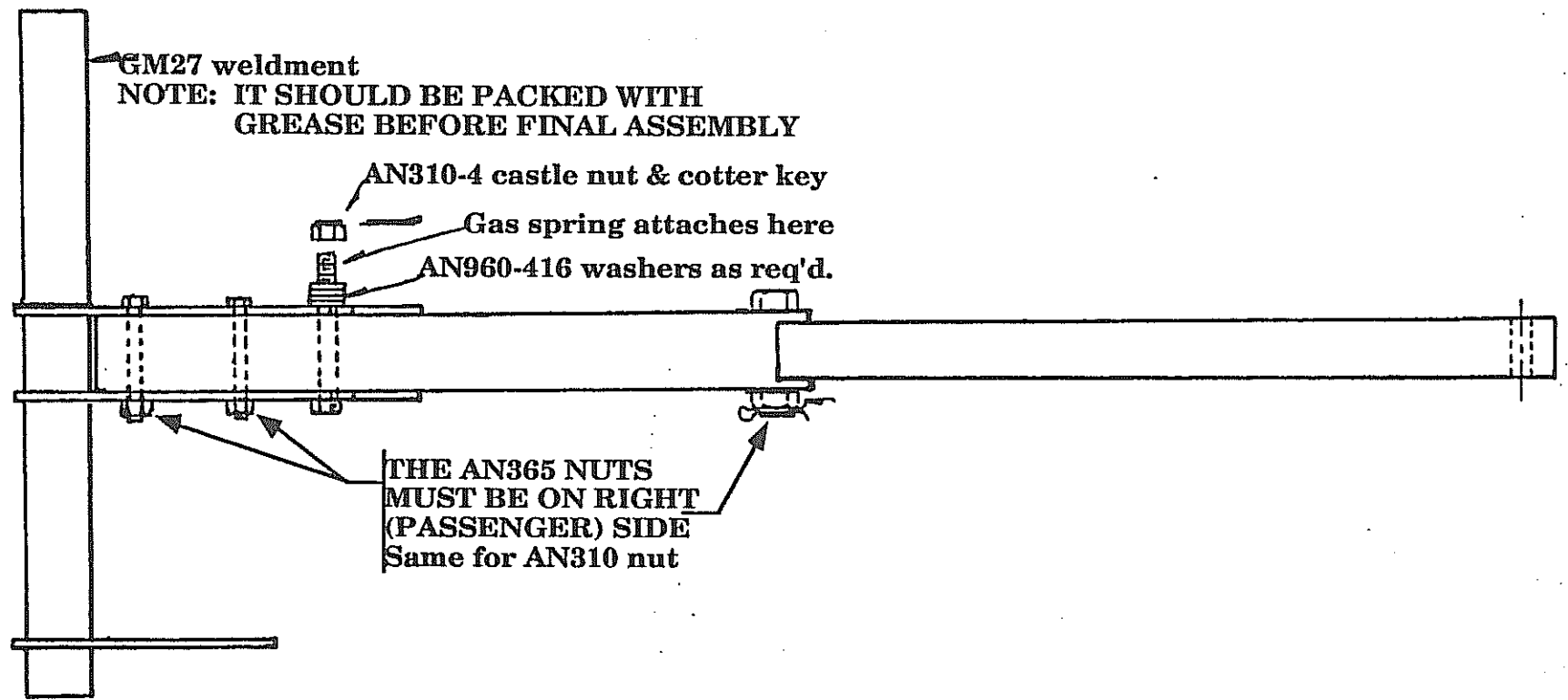
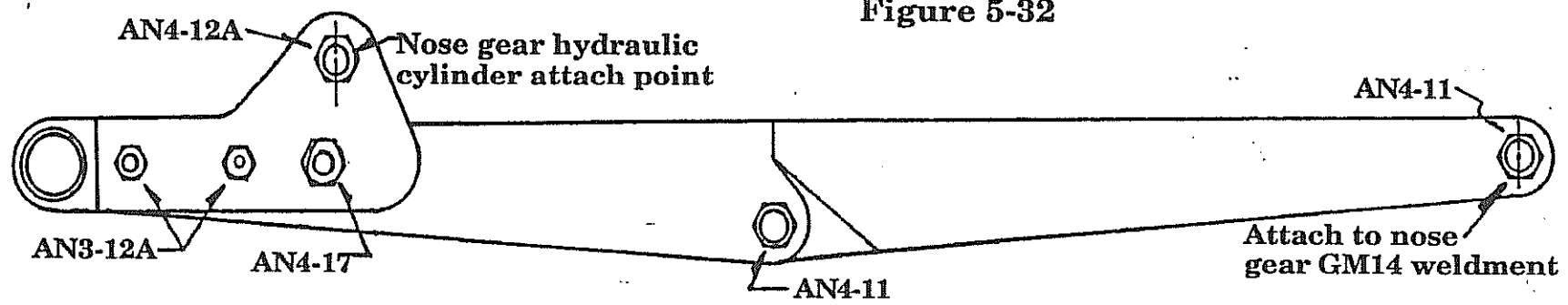

CROSS SECTIONAL VIEW FROM FWD, LOOKING AFT

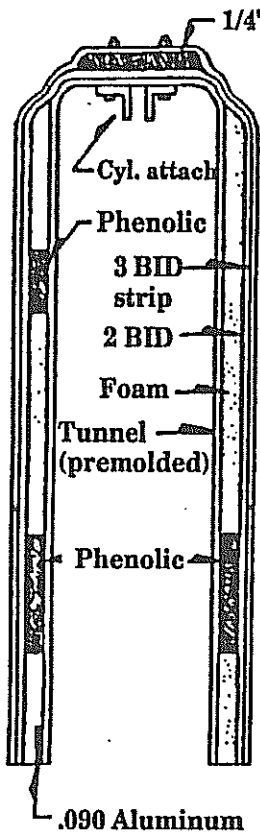

NOSE GEAR TUNNEL

Figure 5-33

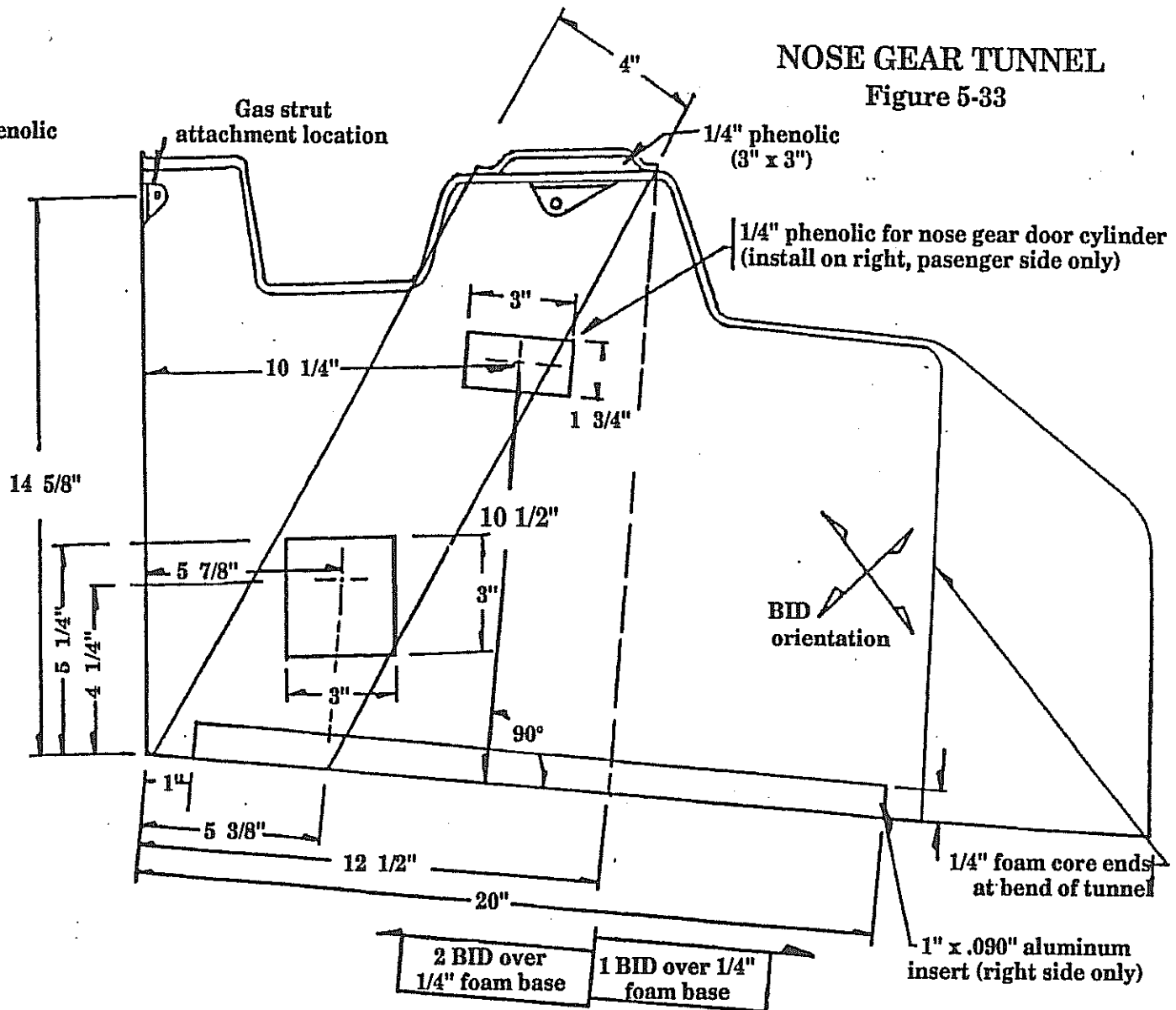

Nose gear pivot pin installation

Figure 5-34

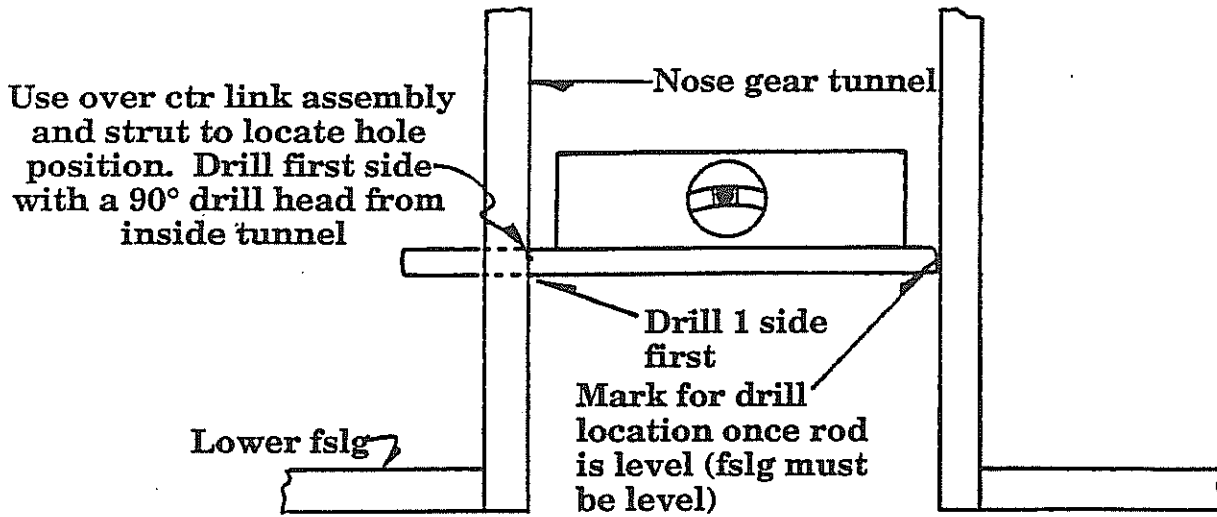

Drag link / tunnel installation

Figure 5-35

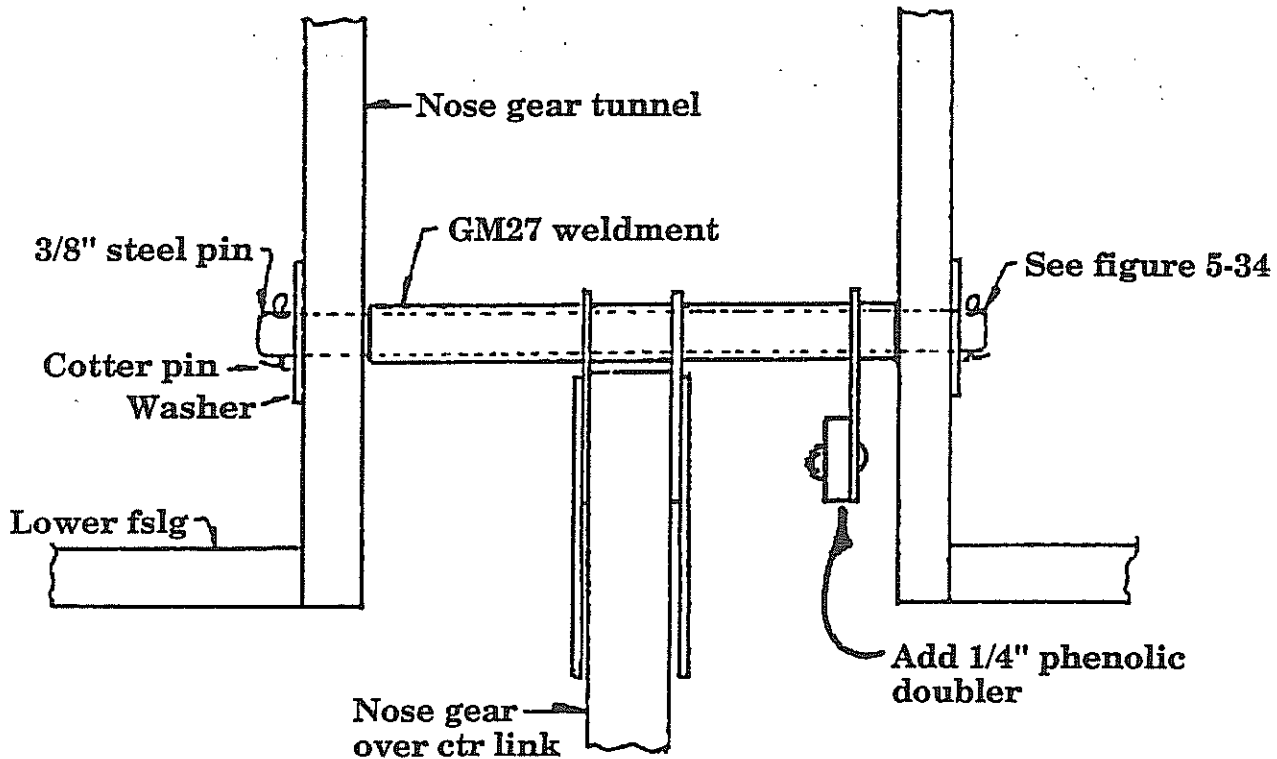

8. From figure 5-36, make the micro switch attach plate from the .090" aluminum sheet.
9. With the gear in the down locked position, mount the plywood or phenolic 1/4" attach block with the micro switch so that there will be adequate adjustment range for the micro switch. The switch should be positioned so as to solidly contact the swing arm on the GM27 weldment. Shim if necessary. Note also that the GM27 tab has a small 1/4" phenolic doubler added to enlarge the contact area.
 The micro switch assembly must be mounted such that the GM27 tab or striker hits the trigger on the micro switch in a movement direction that does not place any bending or pinching motion onto the switch trigger. The trigger should also be contacted by the GM27 tab about 1/2" outbd of the edge of the micro switch body. This is not critical but if it contacted at the very tip of the trigger arm, the arm might simply bend and not depress the activating mechanism properly or reliably.

Nose gear micro switch

Figure 5-36

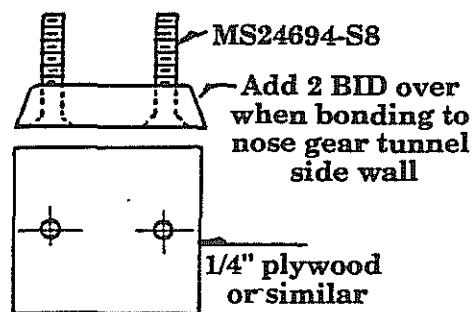
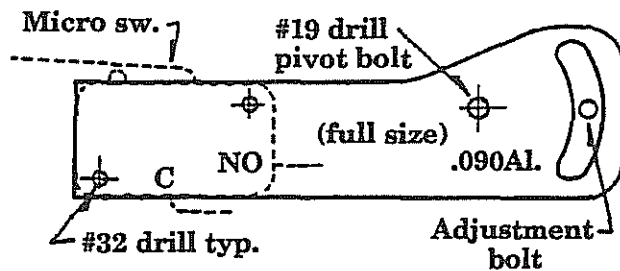
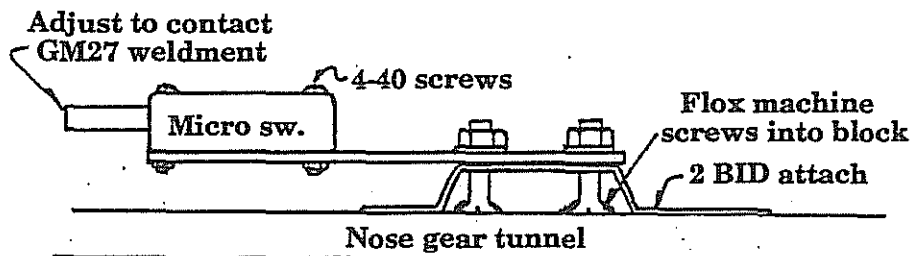

L. Nose gear gas strut installation

The gas strut is there to insure that the nose gear will free-fall out into the airstream without hydraulic assistance. This must be checked during flight on a regular (monthly) basis.

1. Out of 1" x 2" aluminum angle stock, fabricate the two attach brackets per figure 5-37.
2. Bolt these attach brackets to the firewall per figure 5-37 and blueprint "N". Note that the gas strut does not align in the center of the tunnel, it is to the pilot's side (left). This is for adequate clearances from the drag linkage.

The easiest method of attaching this strut to the firewall is to first assemble the brackets temporarily onto the top of the strut. Position the end up into the nose gear tunnel such that there is about 3/8" of compression required in order to get the other end of the strut onto the GM27 weldment when the gear is down and locked.

With this confirmed, mark the location of the brackets onto the inside of the firewall and then drill for their attach bolts.

3. It is a good idea to pot the bolt heads onto the firewall (fwd face) so that you can merely tighten the nuts from the aft side (or tunnel side). Otherwise the bolts will be either under the stainless which would make removal impossible or you would have to drill through the stainless steel firewall facing and insert the bolts through the entire firewall assembly. That too is acceptable. If you choose to pot the bolts into the firewall, simply apply a small mound of epoxy / flox over the bolt head and cover with a 1 BID patch about 2" square. Either method is OK.
4. Attach the gas strut using the AN4 bolts with castle nuts and cotter pins.
5. The attachment of the gas strut to the drag link will require approximately four (4) AN960-416 washers to be used as shims to move the strut outbd of the GM27 weldment for clearance purposes. The minimum amount of shim stock washers should however be used as this will reduce the bending loads on the 1/4" attach bolt. Push the gear through full travel to confirm adequate clearances through full travel.



Nose gear gas strut
Figure 5-37

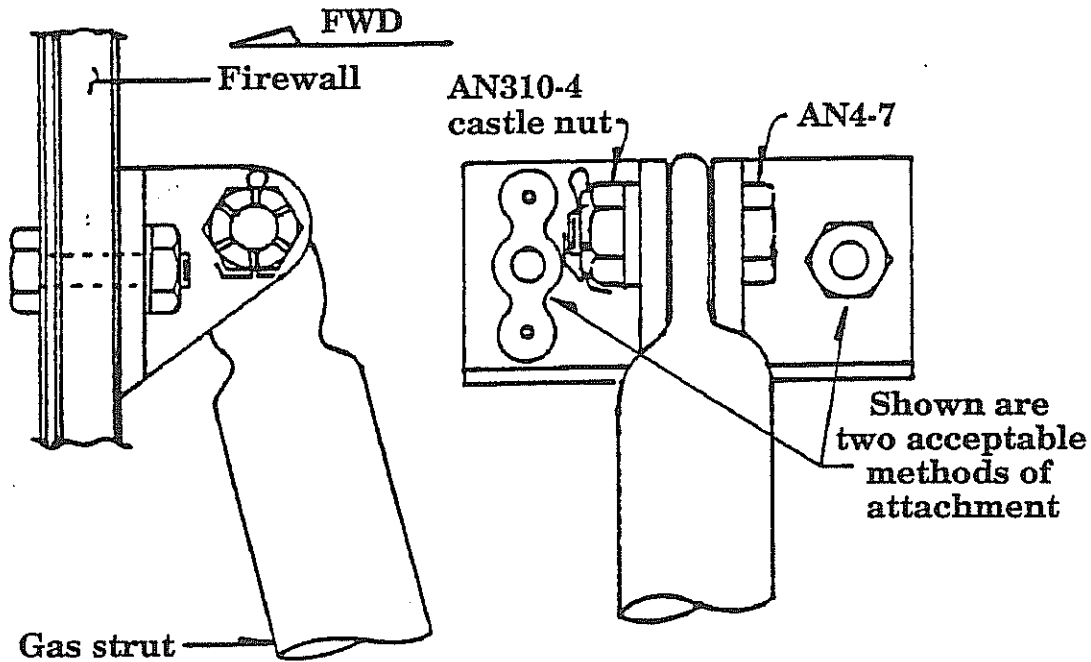

NOTE: The gas strut is quite stiff (about 100 lbs.) so you would have a difficult time trying to compress it the 3/8" in order to mount its end to the GM27 weldment. This is easily overcome. First loosen the micro switch and swing it downward (away) from the GM27 tab. Then remove the attach bolt where the lower arm of the drag link attaches to the nose gear strut. Now the drag linkage can be lowered to where the gas strut can be easily slid onto the attachment bolt. You can then easily push the drag link arm up (you'll have easy leverage now) and re-attach the 1/4" bolt through the nose gear strut.

NOTE: Once the nose gear retract cylinder is attached, you may have to remove it as well in order to allow the drag link assembly to be rotated down past its normal position when mounting the gas strut.

Gas strut attach bracket

Figure 5-38

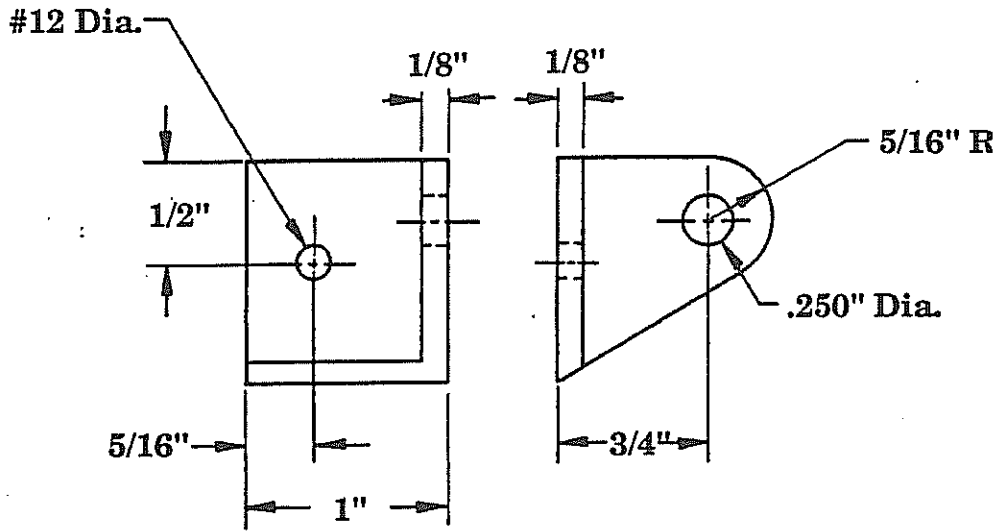

Gear Hydraulics

The hydraulic system is actually very simple and straight forward. Basically there is a cylinder attached to each gear; these cylinders will each have a high pressure line and a low pressure line attached to them. The power pack will have a high pressure port and a low pressure port. **The high pressure port is on the LEFT (as you face the pump), the low pressure port is on the RIGHT.**

HIGH PRESSURE (UP): 1200 PSI LEFT SIDE PORT
LOW PRESSURE (DN): 550 PSI RIGHT SIDE PORT

There is also a small pressure switch for high and low pressure sides. Be sure to not mix these switches up since they look the same. These switches will control the shut off of the pump motor. Hydraulic pressure alone will hold the gear up, the gear will self lock into the down position and hydraulic pressure will simply follow as a backup.

There is also one mechanical valve placed in the system which will connect the high pressure side to the low pressure side. This dump valve will allow the gear to free fall into the down and locked position when opened.

Power pack and pressure switch

Figure 5-39

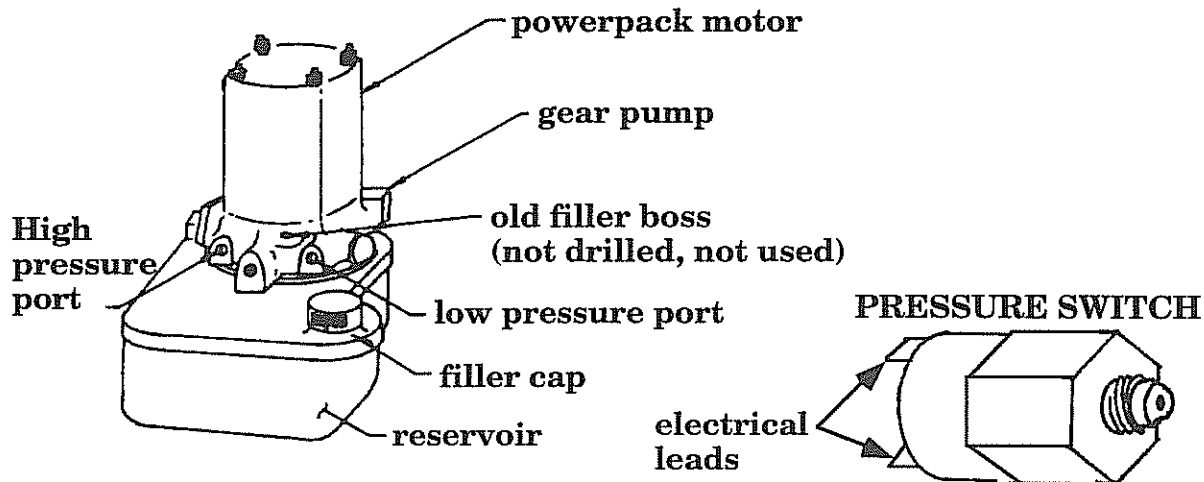

NOTE: The pressure switches will have two leads.

M. Nose gear hydraulic cylinder

1. From some 1" x 2" angle stock, cut the two cylinder attach brackets and mount to the top inside of the tunnel per figure 5-40.
2. To assure proper fit, assemble the cylinder with rod end bearing screwed on to the mid position on the threaded shaft of the cylinder.
3. Position the cylinder into the tunnel with the gear in the down position. The cylinder should be fit as far fwd as possible on the tunnel without actually contacting the contour of the tunnel itself. Check that the cylinder will attach to the link assembly with cylinder shaft fully extended. Then retract the nose gear and check that the cylinder is still in satisfactory alignment.
4. Mark the cylinder attach location and drill the four #12 holes. Attach the two aluminum brackets (2 bolts each) with the bolt side down (put the nuts on the top side of the tunnel). Otherwise you'd have trouble getting the bolts out from the inside once the header tank is installed.



NOSE GEAR HYDRAULIC CYLINDER ATTACH

Figure 5-40

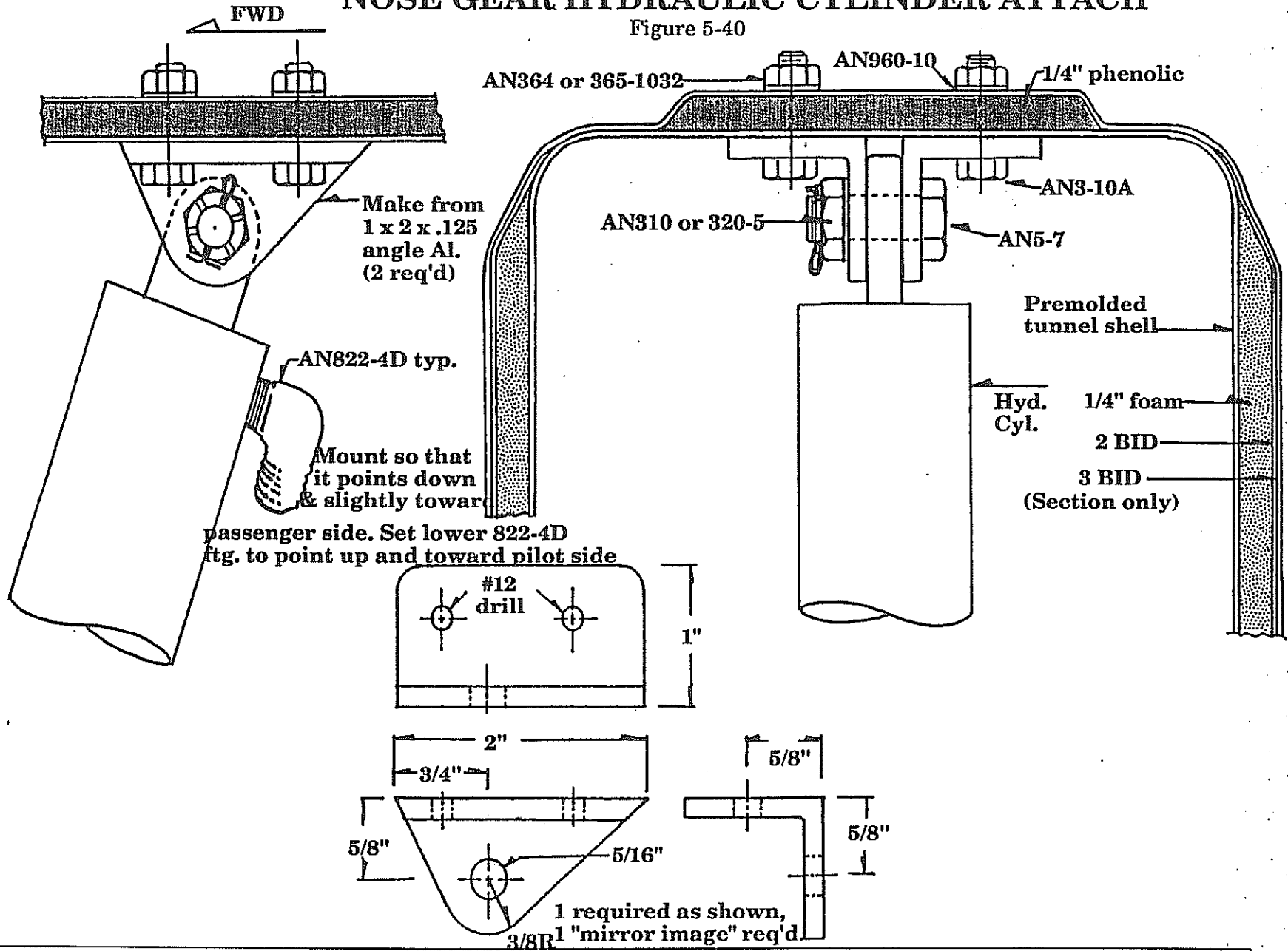

5. Insert the two 90° fittings into the cylinder body per figure 5-40. Use pipe thread sealer (Recoseal™ works well). Do NOT use teflon tape, as it can shred and get into the lines.
6. The cylinder will attach to its attachment brackets with the AN5-5 bolt shown in figure 5-40, and it must be cotter keyed.



- N. **Main gear hydraulic cylinder and attach point**
This attachment will secure the main gear cylinder to the airframe.

Main gear hydraulic cylinder attach point

Figure 5-41

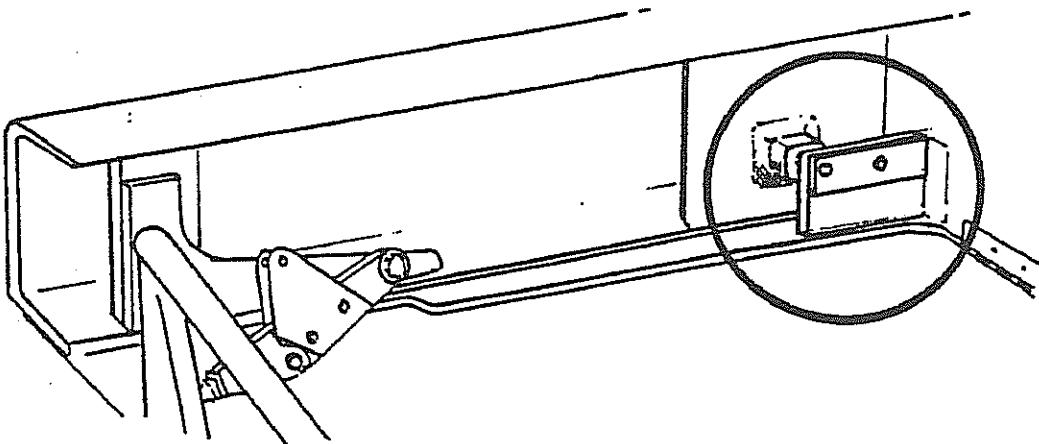

1. Locate and mark the attach bolt location for the cylinder per figure 5-42. Check that it does position through the phenolic insert earlier placed into the spar closeout web.
2. Cut a piece of 1/4" phenolic that will fit to the closeout rib surface. Also cut the .090 aluminum and phenolic spacer block per figure 5-42.
3. To establish proper fwd to aft position of the hyd. cylinder base (5/16" bolt), place either a 1/4" rod or the retract cylinder itself (this is best) through the pickup point on the overctr link and extend it inbd to the approximate attach point. Hold in position while cycling the gear up and down. Position the cylinder base so that there is no bond at any point during retract cycle. (Should be approx. parallel to main spar, see figure 5-43.)
4. Fit the 1/4" phenolic into position and apply BID per figure 5-42. Be sure to allow some added dimension for the inner BID plies (about .050"). Keep the aft side BID smooth since there will be a pc. of .090 aluminum later attached.
5. Fit and install the phenolic spacer block. It can be held in place with either a small clamp or by simply wedging a suitable block in position and lightly clamping across the whole assembly, see figure 5-42.
6. Build a small fillet out of floc and add the BID around this spacer block per figure 5-42.

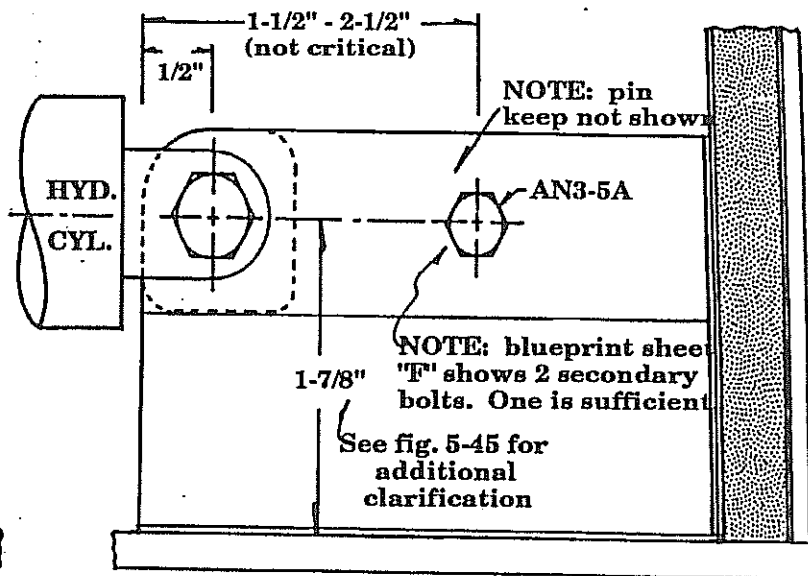
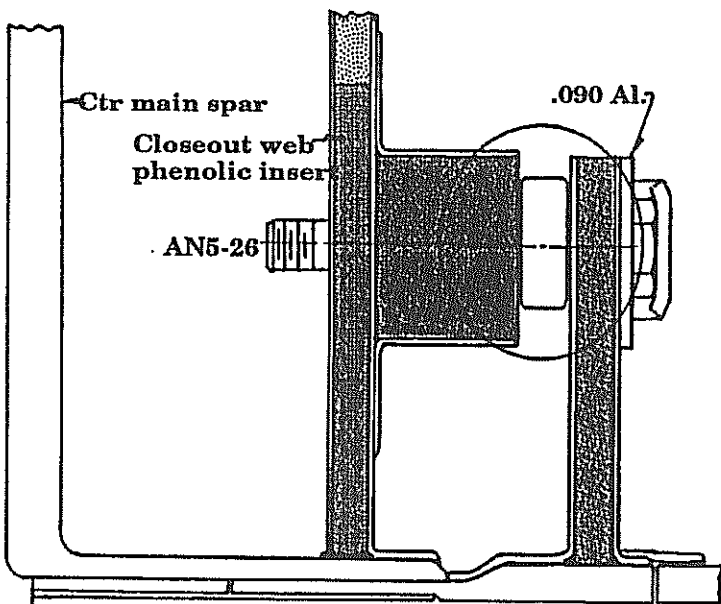
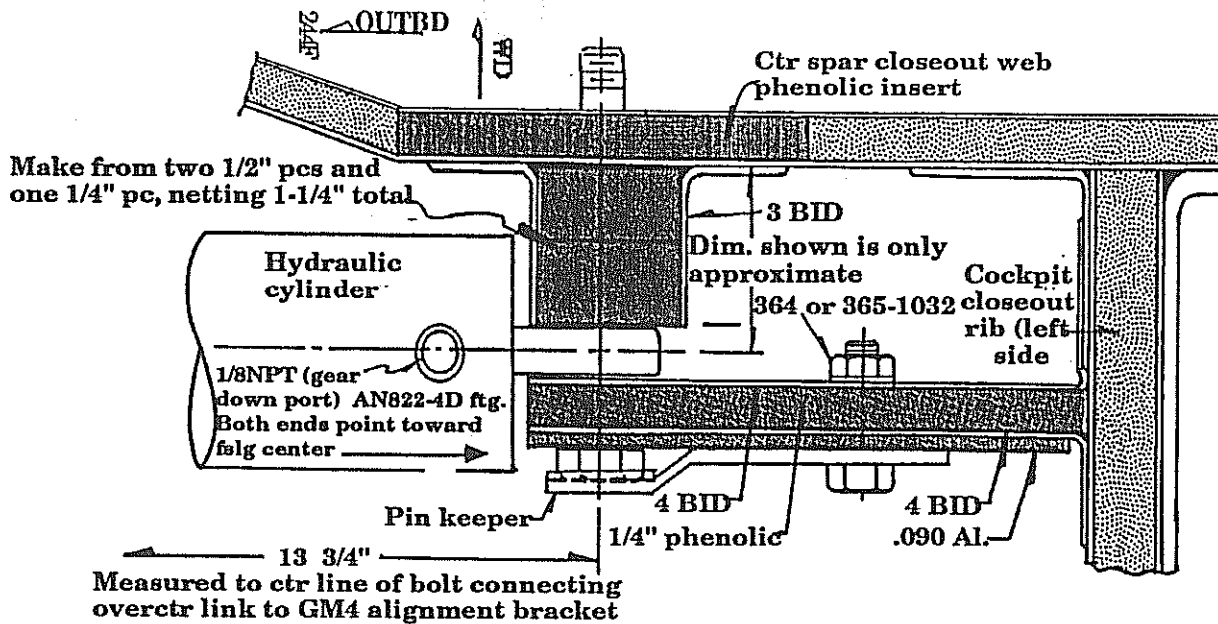

Hydraulic cylinder attach
Figure 5-42

7. Cut the aluminum plate from .090 aluminum. Bond this to the aft face of the 1/4" phenolic using structural adhesive.
8. Drill (#12 bit) for the secondary attach bolt (AN3-7A) per figure 5-42. The bolt is permanently attached and helps carry the cylinder loads. It can be used to help clamp the aluminum during the above step 7 cure.
9. After cure, check alignment and position of the cylinder, then drill the 1/4" through hole for the attach bolt. This bolt will attach all the way through the spar closeout web. This completes the attachment.
10. Install the hydraulic fts. into the cylinder and install the cylinder per figure 5-42.



O. **Main gear cylinder attach - pin keeper**

Refer to figure 5-42. The top illustration shows the AN5 bolt extending through the entire structure. The means to "keeping" this bolt (or pin as we will use it) in position is with a "keeper" plate over the top. The AN3-5A bolt will locate the keeper plate.

Follow the drawing below for fabrication of this keeper plate.

NOTE: As a point of safety, after drilling the 5/16" hole for the AN5 bolt, you should make a quick check that you've drilled through the entire closeout web (and no farther). This will be easy with a short piece of wire having a small hook bent onto the end. Slip the wire into the hole and locate the innermost surface of the closeout web. This should be easy using the hook on the end of the wire.

Verify that the bolt shaft does fully penetrate and extend the full distance by checking it against the measured wire length.

Pin keeper

Figure 5-43

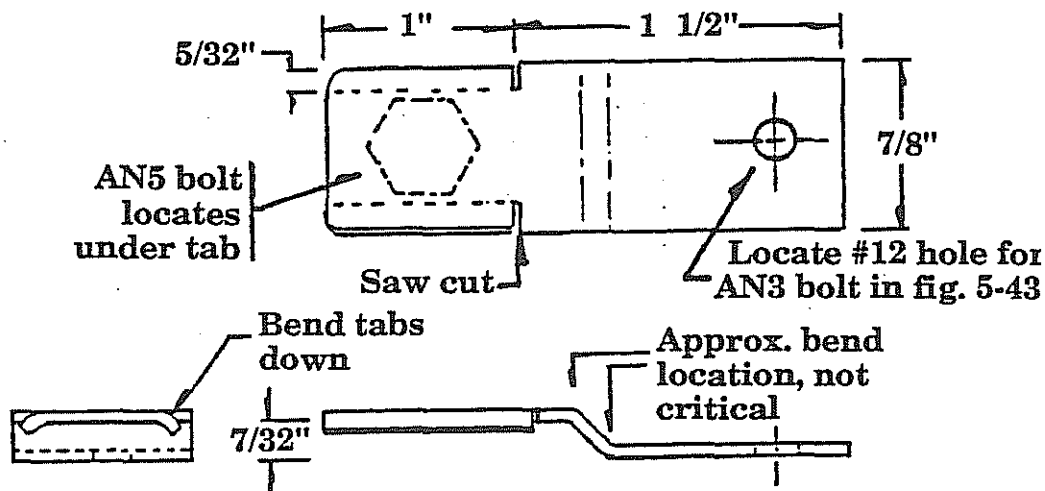

P. Main gear hydraulic cylinder attach point

When positioning for the main landing gear hydraulic cylinder attach point, it is best to use the actual cylinder itself as a guide. Check that there is the proper clearance between the cylinder shaft and the over ctr link assembly, see figure 5-44, below. There should be about 1/8" clearance.

If the cylinder is mounted too low, it will contact the over ctr link assembly, which is not acceptable and would have to be corrected by relocation of the cylinder attach point (rather messy). If the cylinder were mounted too high, it could interfere with the aileron push rods which will be running above it (equally messy and unacceptable). See blueprint "F" for additional clarification.

Main gear hydraulic cylinder attach point

Figure 5-44

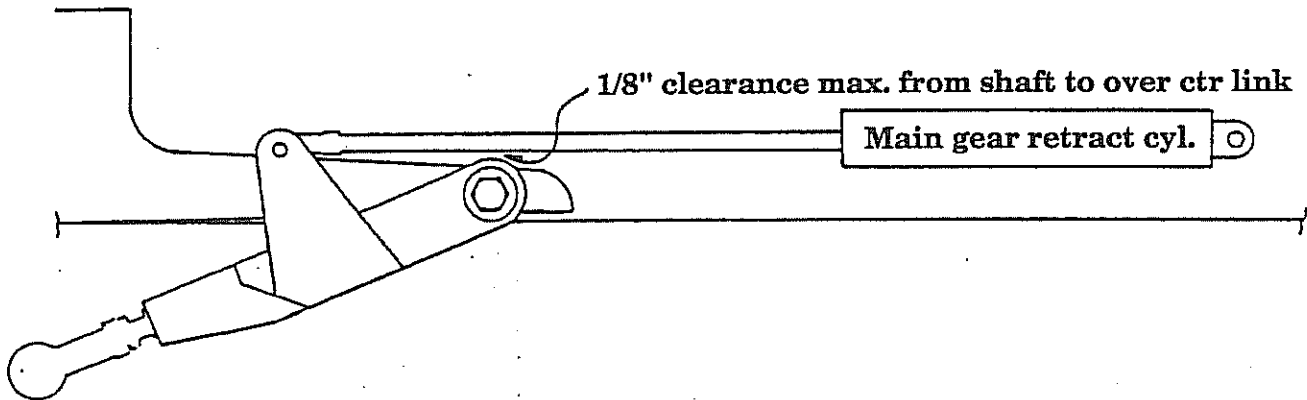

Locating hydraulic cylinder attach points

Figure 5-45

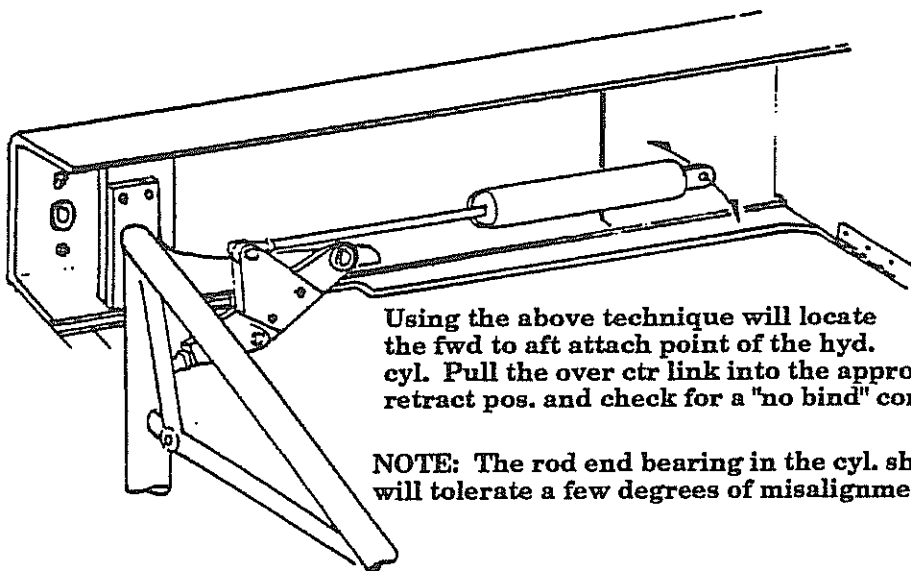

Using the above technique will locate the fwd to aft attach point of the hyd. cyl. Pull the over ctr link into the approx. retract pos. and check for a "no bind" condition.

NOTE: The rod end bearing in the cyl. shaft will tolerate a few degrees of misalignment.

Q. Hydraulic power pack installation

The power pack is a self contained unit comprising motor, gear driven pump and reservoir. The unit is generally mounted behind the baggage bulkhead. It can be attached to an aluminum plate which, when combined with a phenolic side plate, also attaches the two electric relays which activate the motor. This makes for a tidy installation.

1. Make an aluminum attach plate with phenolic side panel per figure 5-46.
2. Locate and insert three 1/4" phenolic pcs into the baggage bulkhead. Two must align with the two 3/8" motor attach bolt holes and a third is used to further anchor the aluminum plate.
Be sure that the pump adequately clears the top of the bulkhead and the cutout for the elevator push rods.
3. Install the pump and master relay to the aluminum panel. Install the two relays onto the 1/4" phenolic piece which serves as an electrical isolator.
4. The pump and relay wires can be attached prior to installation of the complete unit. You'll need to run three wires (#18) fwd: Gear up, gear down and motor transition light.

Aluminum mounting plate

Figure 5-46

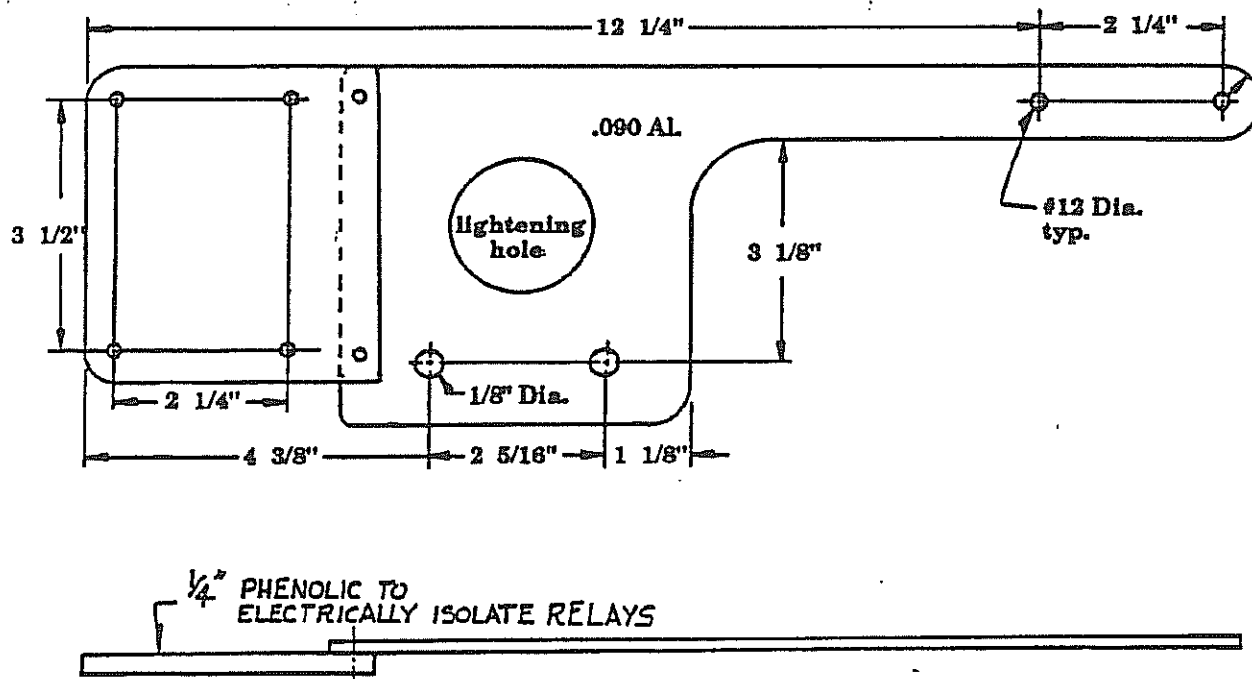

Hydraulic power pack installation

Figure 5-47

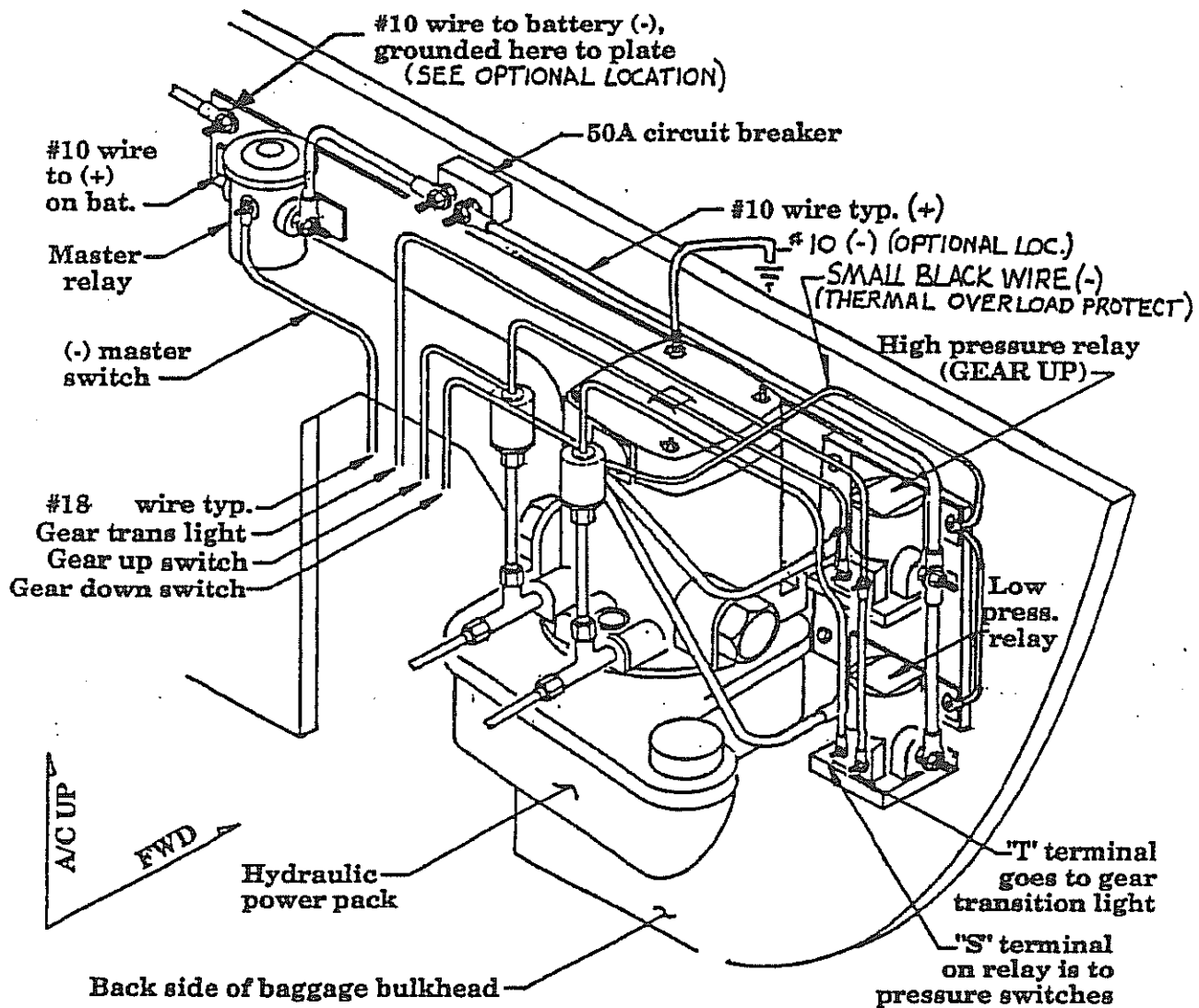

Gear electrical wiring reference

Figure 5-48

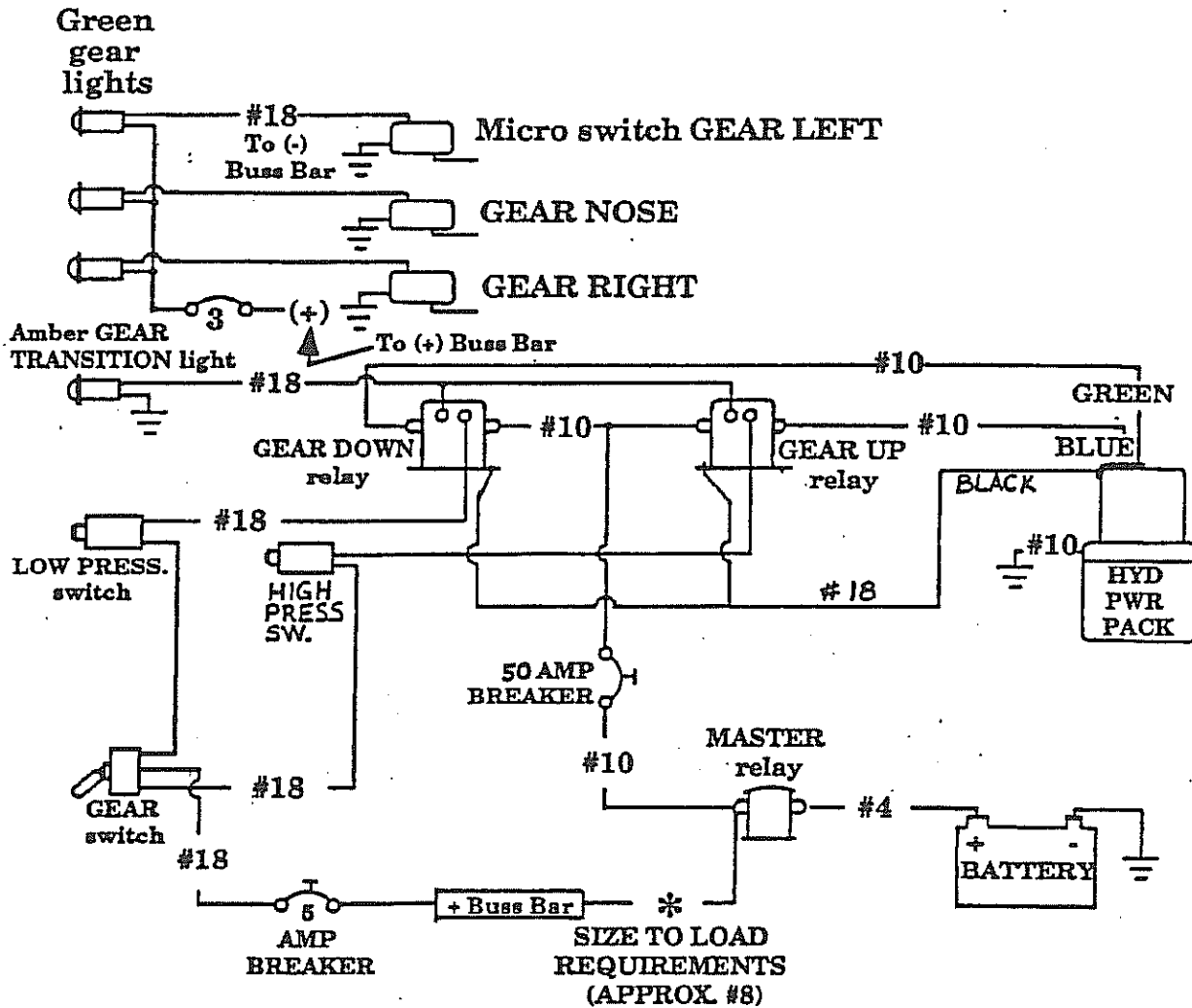

CHAPTER 6: CENTER STUB WINGS

REVISIONS

From time to time, revisions to this assembly manual may be deemed necessary. When such revisions are made, you should immediately replace all outdated pages with the revised pages. Discard the out dated pages. Note that on the lower right corner of each page is a "revision date". Initial printings will have the number "0" printed and the printing date. All subsequent revisions will have the revision number followed by the date of that revision. When such revisions are made, a "table of revisions" page will also be issued. This page (or pages) should be inserted in front of the opening page (this page) of each affected chapter. A new "table of revisions" page will accompany any revision made to a chapter.

Arrows

Most drawings will have arrows to show which direction the parts are facing, unless the drawing itself makes that very obvious. "A/C UP" refers to the direction that would be up if the part were installed in a plane sitting in the upright position. In most cases the part shown will be oriented in the same position as the part itself will be placed during that particular assembly step. However, time goes on and changes are made, so careful attention should be paid to the orientation arrows. That old cartoon of the guy agonizing over the plans for his canoe, built one end up, one end down, should not happen in real life. Especially to you.

CONTENTS

1. INTRODUCTION
2. DRAWING LIST
3. SPECIAL PARTS, TOOLS & SUPPLIES LIST
 - A. PARTS
 - B. TOOLS
 - C. MATERIALS & SUPPLIES
4. PROCEDURE
 - A. JIG PREPARATION
 - B. MAIN GEAR MIDDLE DOORS
 - C. NOSE GEAR DOOR

1. INTRODUCTION

The inboard wing sections (stub wings) extend from fslg fillet to the BL 50 position. The partial rib will be installed per figure 6-1. It can be installed at a later time if preferred. The stub wing skin should be installed permanently only after the outbd wing skin alignments have been checked. It is not necessary to have the outbd wing skins to perform this check. The stub wing skins can however be temporarily clecoed into position, thus if slight changes are required, they can be easily accommodated.

The final fit and attach will require the fslg to be inverted and levelled.

Stub wing
Figure 6-1

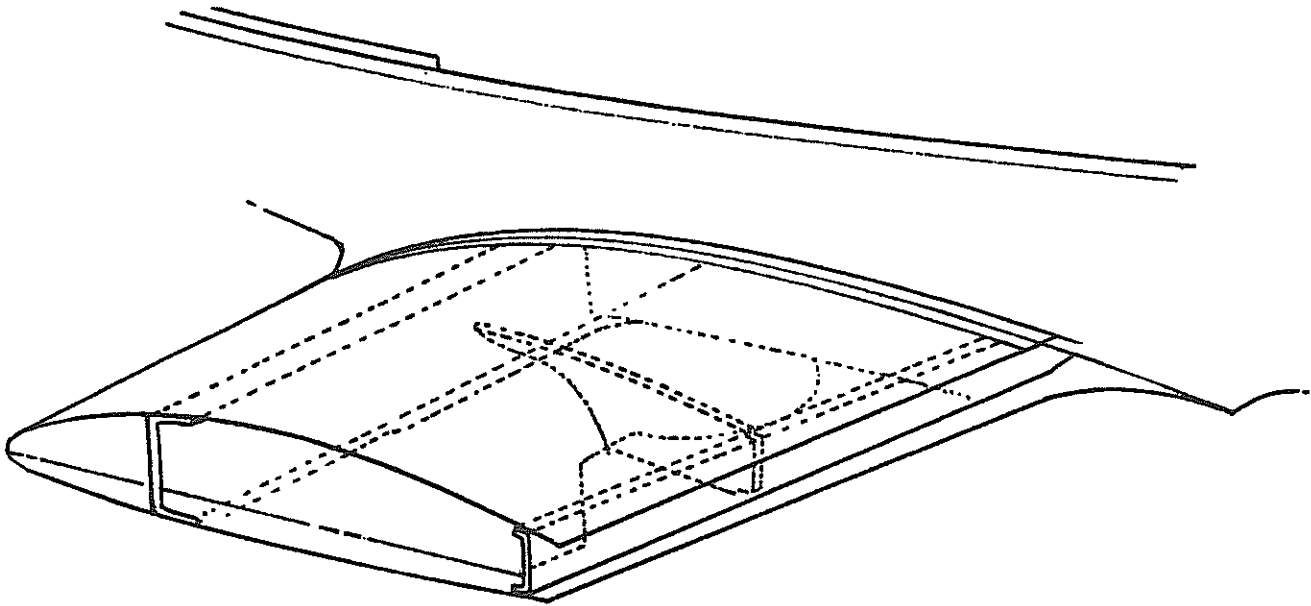

For purposes of section continuity, the stub wing section will end with the permanent bonding in position of the upper stub wing skin. It is recommended that the flap linkage be installed into the stub wing prior to the permanent bond. The installation can be accomplished later but it is a bit easier with the stub wing skin removed. See Chapter 10 section "E" page 10-24, titled "Flap bellcrank assembly into fslg and stub wing".

2. DRAWING LIST

6-1	page	6-2	Stub wing
6-2	page	6-7	Fitting partial ribs
6-3	page	6-9	Levelling BL 50 rib
6-4	page	6-10	Wing tip jig
6-5	page	6-11	BL 50 string line
6-6	page	6-12	BL 50 level reference
6-7	page	6-13	Clamping straight edge to trailing edge
6-8	page	6-14	Main gear middle doors
6-9	page	6-15	Removing core material for adequate clearance
6-10	page	6-16	Middle gear door
6-11	page	6-17	Middle gear door - mount bracket
6-12	page	6-19	Aligning attach point and gear door
6-13	page	6-22	Applying weight to establish preload
6-14	page	6-23	Location of hinge on gear door
6-15	page	6-24	Nose gear door cylinder installation
6-16	page	6-25	Nose gear door cylinder attach bracket
6-17	page	6-25	Nose gear door control horn

3. EQUIPMENT REQUIRED

A. Parts

- 1/2" foam
- pop rivets (about 3 doz.)
- 2 carriage bolts or similar (approx. 3/8" dia. x 1 3/4")



Lancair International Inc. Copyright © 1991, Redmond, OR 97756

6-4

Chapter 6

REV. 0/ 11-1-91

CENTER STUB WINGS



B. Tools

- BL 50 rib template
- BL 50 wing jig (fabricate out of 5/8" particle board or similar)
- Water level
- Cleco tool & clecoes



6-5

Chapter 6

REV. 0 / 11-1-91

CENTER STUB WINGS

C. Materials & supplies

- epoxy
- flux
- BID cloth
- structural adhesive



6-6

Chapter 6

REV. 0 / 11-1-91

CENTER STUB WINGS



4. PROCEDURE

A. Installing partial ribs

1. With the fslg upright, fit and install the partial ribs per figure 6-2, see blueprint "C". This rib requires 2 BID per side oriented $0^\circ - 90^\circ$. Use micro to bond into position and attach with 2 BID all around. It is advisable to leave the upper contoured section a little tall so that a good fit can be established against the upper stub wing skin. Spanwise location of this partial rib is not critical, the nearest inch is acceptable. This rib can also be installed after the stub wing skin is attached, it makes no difference.

Fitting partial ribs
Figure 6-2

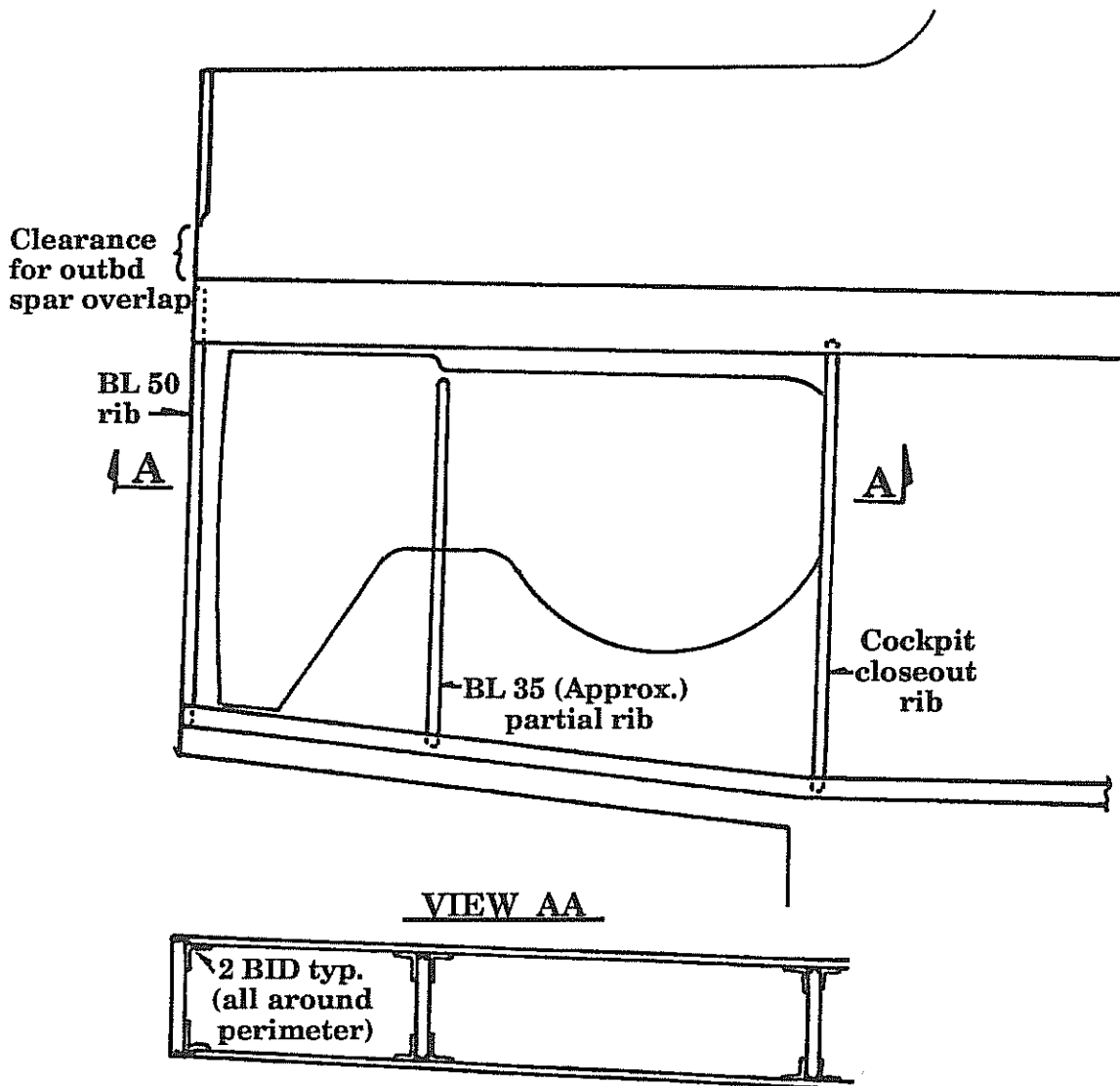

NOTE: It is important to check the fit of the gear doors during the installation of this partial rib. Often that lower portion of the belly pan stub wing which juts fwd in the middle will flex downward or upward. The partial rib will lock its position so check that it is correct by using the gear doors themselves as a fit checking tool.

2. With the BL 50 ribs already fitted and installed, theory would have it that all you would need to do is simply see that the stub wing skins fit snugly to these ribs. In theory, that's true but it is quite easy for a builder to be slightly off in either contour or incidence alignment of these ribs. So, the best method of accurately establishing the upper stub wing skin position is to use a wing contour jig.
3. Trim the stub wing skins so as to have no more than a 1" joggle where they will attach to the fslg fillets. Do not trim anything from the outbd end at this time.
4. Level the fslg in the inverted position.
5. Make a BL 50 upper surface wing jig per figure 6-4. You'll need two of them. If you can possibly make both outbd wings at the same time, then you will also need two similar type jigs for the wing tips. If space requires that you do only one outbd wing at a time, then you'll only need one tip jig.

Levelling BL 50 rib

Figure 6-3

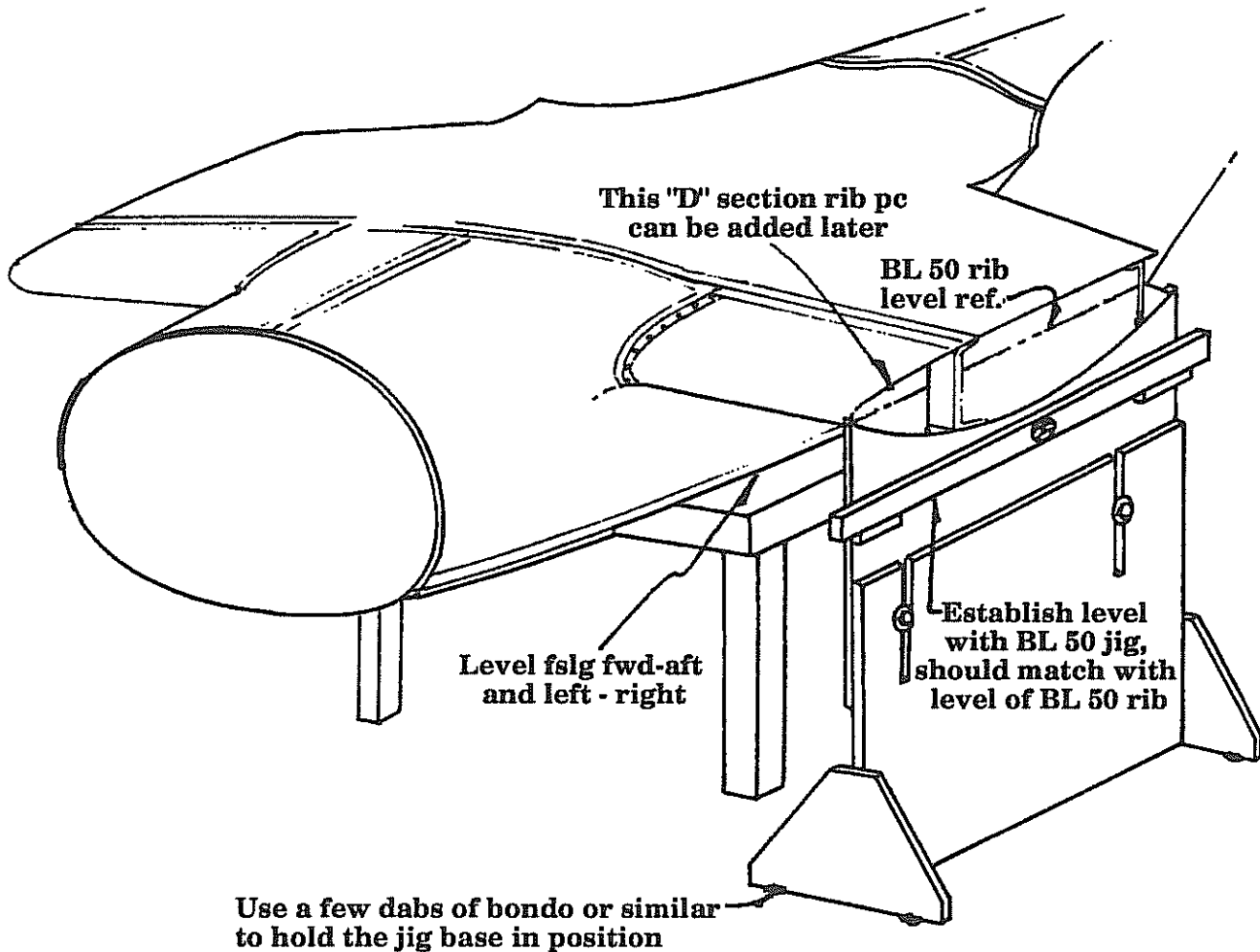

6. You have already fitted the outbd spars and wing tip patterns once when you were checking and establishing the proper fit for the bellypan. It is best to once again attach these outbd wing spars to accurately establish the best alignment of the inbd wing stub skins. If you have the full Lancair kit (vs. just the "A" kit), it will be best to assemble the outbd wings in conjunction with the stub wing skins. This is not, however, necessary.
7. Bolt up the outbd wing spars with a temporary wing tip rib attachment. You could also, at this point, use the wing tip jig instead of the tip rib itself. For the wing tip alignment, use the same 8" dimension from aft face of the outbd spar web to L.E.

8. Position the stub wing skin onto the fslg by first pressing it firmly into the L.E. joggle on the fslg fillet section where the two will interlock. Set one cleco there.

NOTE: Do not drill any cleco holes directly over any spar cap areas. Drilling holes through spar caps will destroy their structural integrity and could result in structural failure. Clearly mark these areas off.

Wing tip jig

Figure 6-4

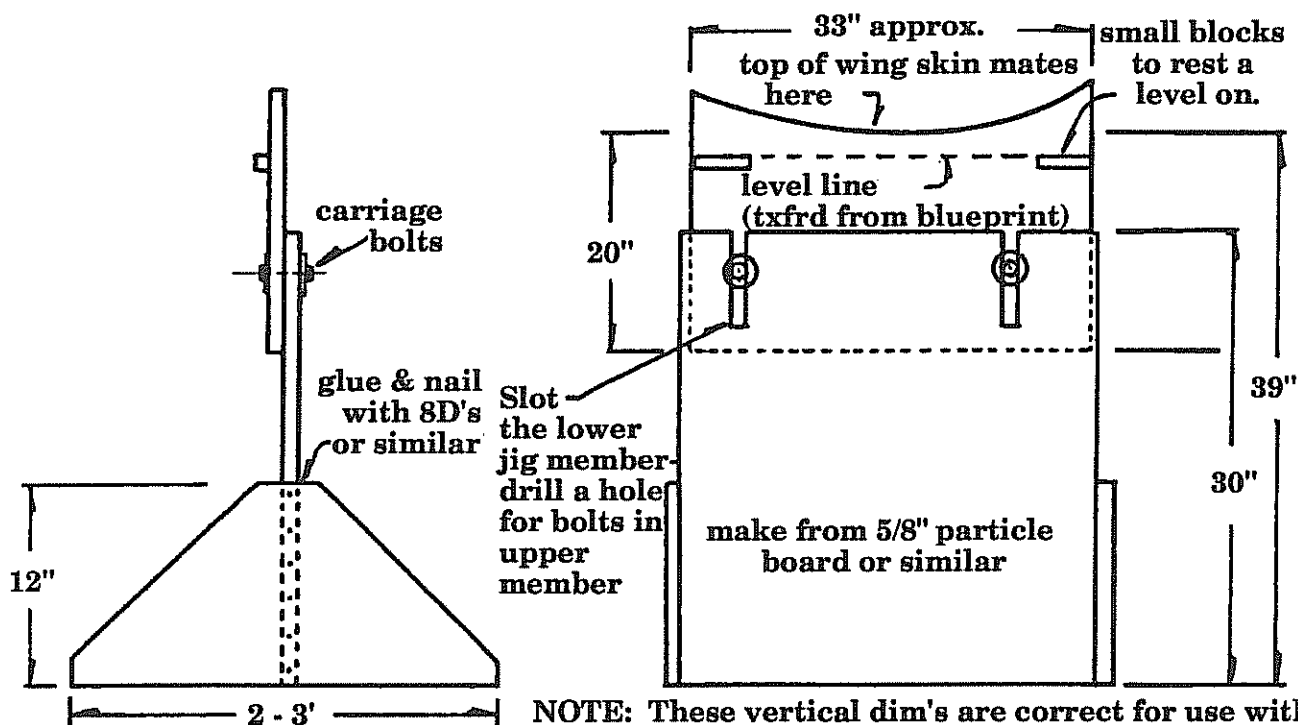

NOTE: These vertical dim's are correct for use with a 30" high bench (onto which the fslg would be placed inverted on longerons).

Cut 4.5" off bottom dims when building the wing tip jig (it will also be a little narrower)

9. Now, the stub wing skin can be adjusted off this cleco. Run a string line from inbd wing fillet to outbd wing tip. Swing the stub wing skin until it properly aligns with the string line at BL 50. This will determine the best possible L.E. alignment of your wing sections and generate a straight wing L.E. Mark the position and/or drill for the remaining clecoes along the fslg/stub wing interlock joggle. **DO NOT DRILL THROUGH FOR CLECOES OVER ANY OF THE SPAR CAPS!!**

The dimension at BL 50 from the spar web to L.E. is typically $9 \frac{3}{4} \pm \frac{1}{8}$ ". However, the above described method is basically fool proof.

10. Next, position and slide up the BL 50 wing jig. It should make a smooth contact along the surface of the wing. With the fslg level rechecked, check the level reference on the BL 50 jig, they should match up. If they do not, perhaps the BL 50 rib, positioned earlier, was not properly positioned. The jig is your best alignment source.
11. Next, check the trailing edge alignments from inbd upper wing skin to outbd wing tip. A straight line should be established. Since the inbd T.E. fillet is established and the wing tip is established, the only alignment corrections possible are at the BL 50 T.E.

It is best to use a long straight edge clamped from inbd fillet to wing tip, particularly when attaching the outbd upper wing skins. When only attaching the inbd stub wing skins, a short straight edge aligned to the string line is O.K.

NOTE: When checking with the string line, the inbd end of the string line should be held tightly against the surface of the wing and slightly outbd of the fslg joggle since that joggle is on a section of the stub wing which is still rolling down to meet the wing contour. Hold it outbd by approximately 1" - 2".

While the stub wing skin is in position, mark the BL 50 trim line. A nice straight line is primarily what you want to establish. When the stub wing skin is removed, trim to that line before attaching permanently.

BL 50 string line

Figure 6-5

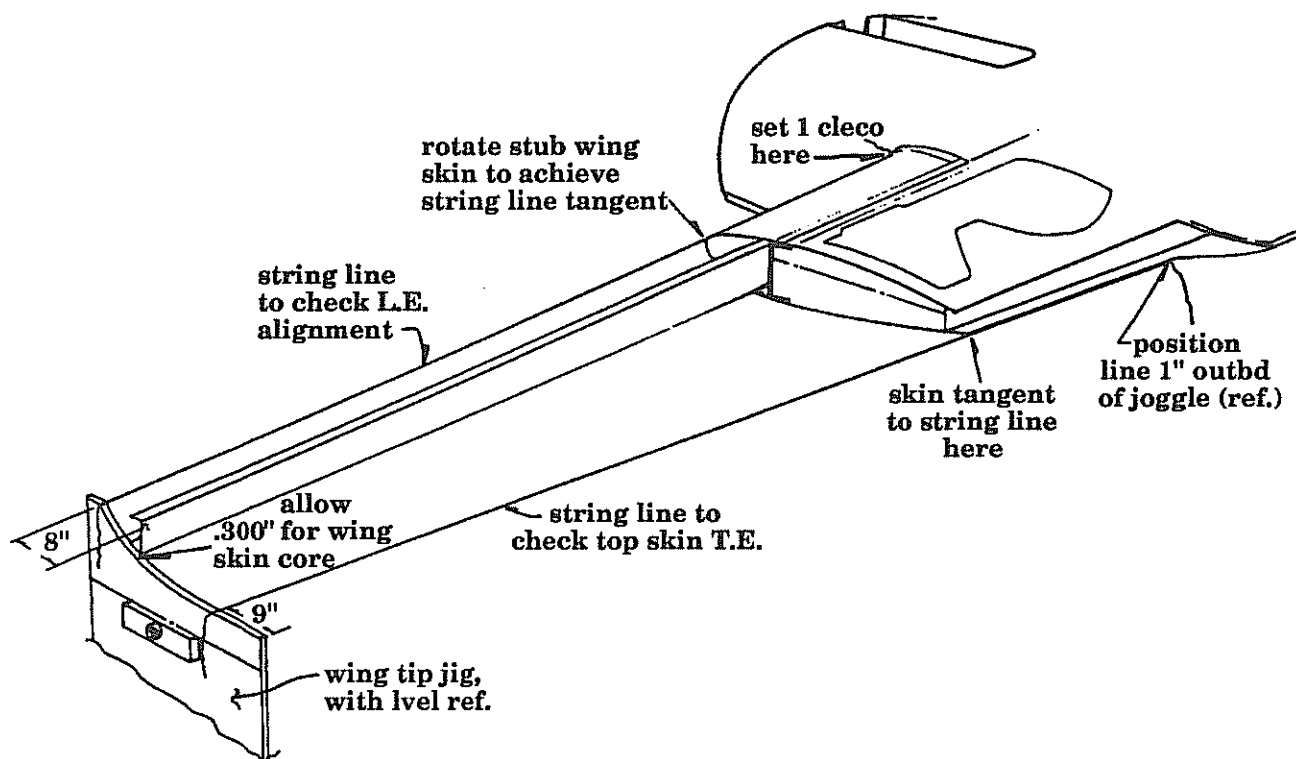

BL 50 level reference

Figure 6-6

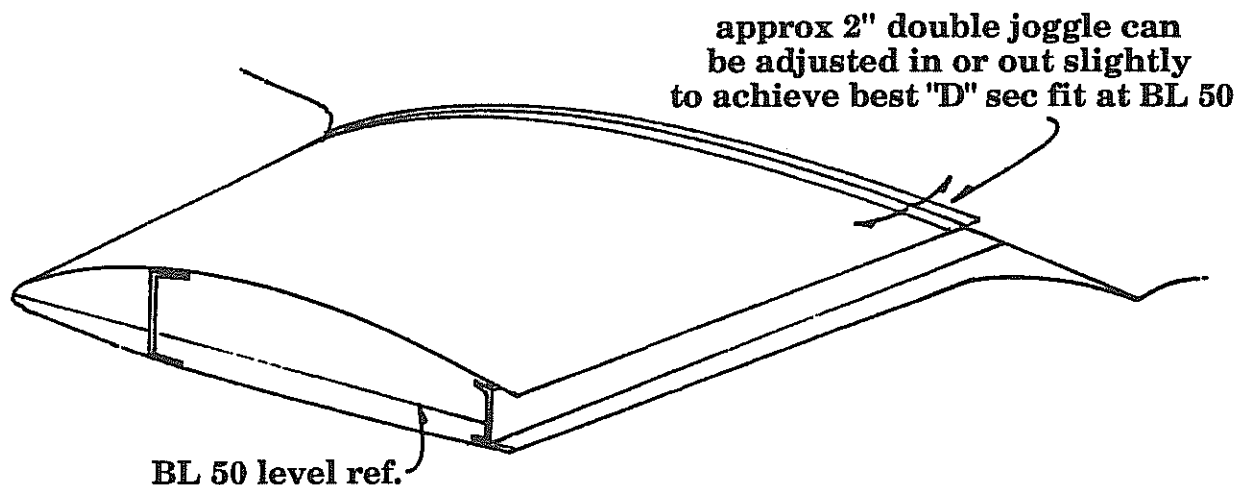

12. With all of the above position checks made, you're ready to bond the stub wing skins into permanent position. Prep the surfaces as usual (36-50 grit sanding with a good cleaning etc.) and spread a coat of structural adhesive onto the fslg fillet joggles - spread a coat onto both surfaces.
13. Often, a filler is required between the skin and the aft ctr spar cap - use micro for this filler. A filler is also often required between the fwd spar cap and wing skin, use flox for this filler. Use micro along the BL 50 rib/skin joint line. For the main spar filler, use plenty of flox so that you get a good squeeze out when clamping into position. Scrape off all excess. Also, place plastic tape over the outbd spar caps and along the ctr main spar web on the fwd face so if adhesive squeezes out in the "D" section, it won't get permanently stuck to anything.
14. Slip the skins into position and set with temporary pop rivets along the fslg joggle. Use light clamping pressure along the main spar bond lines. Use a straight edge to hold the T.E. in proper alignment and straight. Slide the BL 50 wing jig up into position and recheck for level alignment. Allow to cure.
15. After cure, add the BID tapes. These are typically 2 BID along all surface junctures except at the upper main spar cap line, use 3 BID there.

Wing Skin/Spar and Spar Fslg Attachment

Figure 6-6b

TYPICAL SPAR TO WING SKIN ATTACHMENT

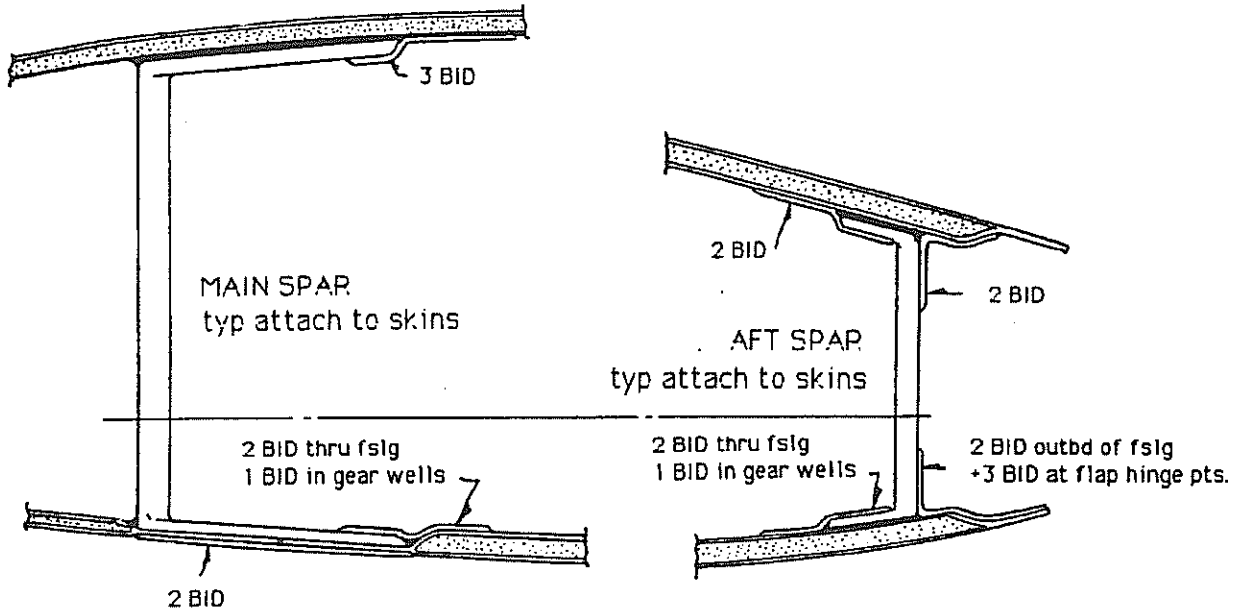

TYPICAL SPAR/FSLG BOTTOM PAD ATTACH

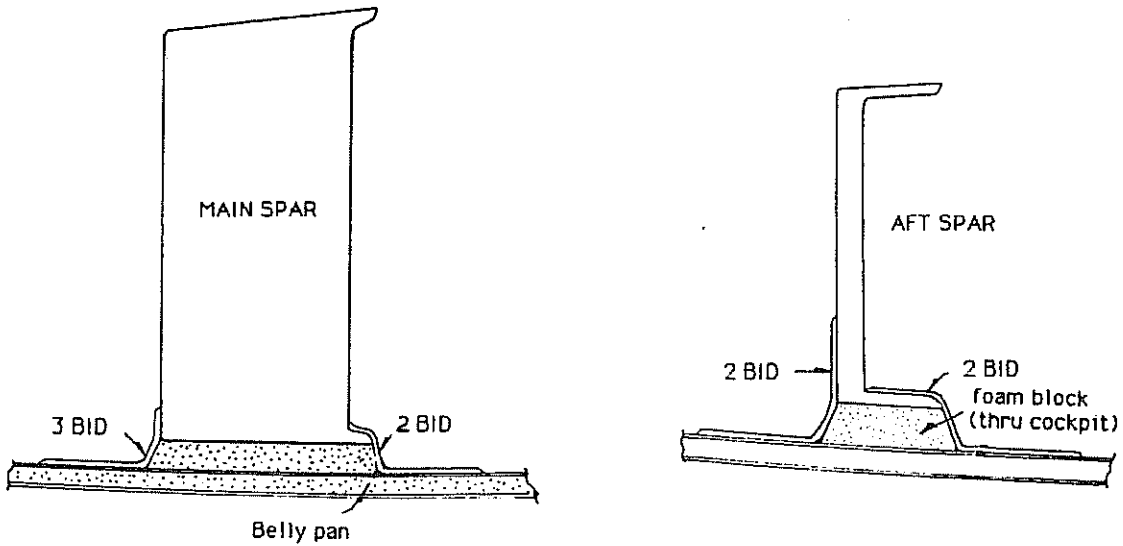

Clamping straight edge to trailing edge

Figure 6-7

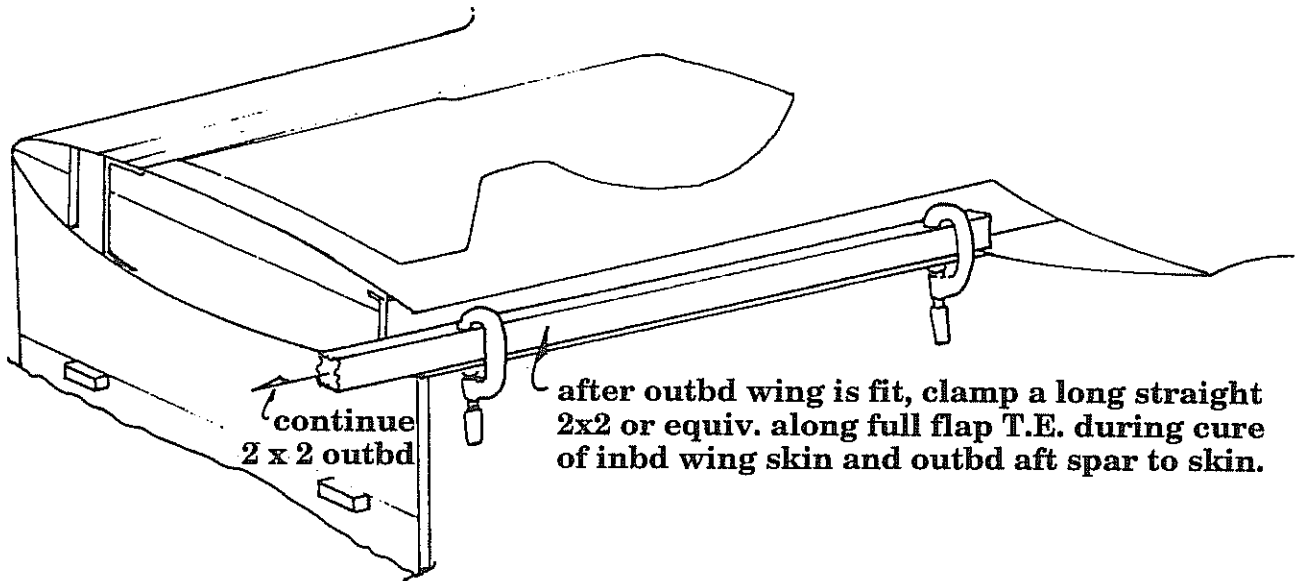

B. Main gear middle doors

With the fslg still in the inverted position, it is advantageous to complete the landing gear door installations.

Main gear middle doors

Figure 6-8

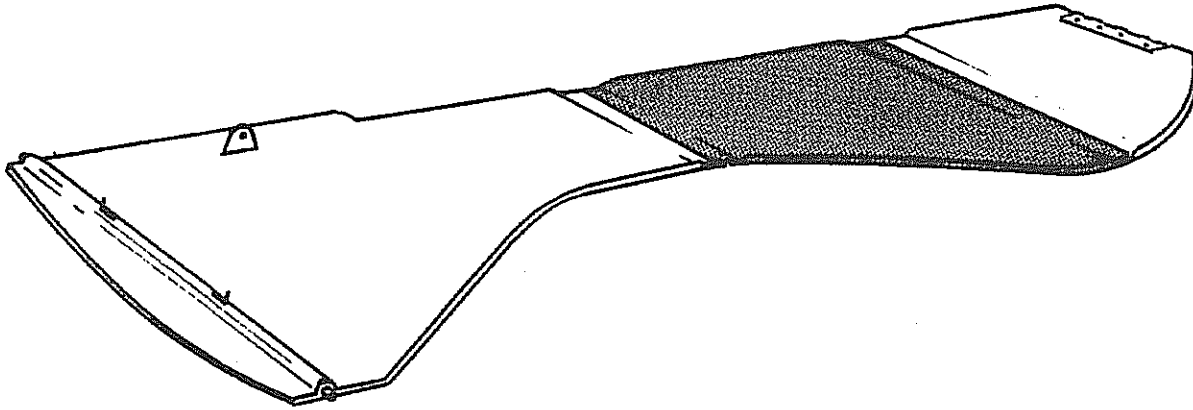

NOTE: it is best to not fit the middle gear door until you have established the desired main gear length which can vary somewhat by choice. See page 5-9, figure 5-3. Any variation in the length of the compression assembly will swing the gear leg and thus affect the gear door orientation on it.

1. With the main gear itself all installed, place it in the retract position and fit the middle door in its proper position (mating to the lower wing skin).

If there is any interference with the landing gear leg preventing a flush fit of the door, mark the interference area for adjustment.

The gear is quite close to the inner skin at this middle door location and sometimes requires the removal of the 1/4" core material in order to achieve a truly flush fit of the door to the lower wing skin. If this is the case, cut the inner skin in the proper area along the gear leg and scrape out all the core material. Add small 1 BID pieces to seal off the core and proceed with the installation.



Removing core material for adequate clearance

Figure 6-9

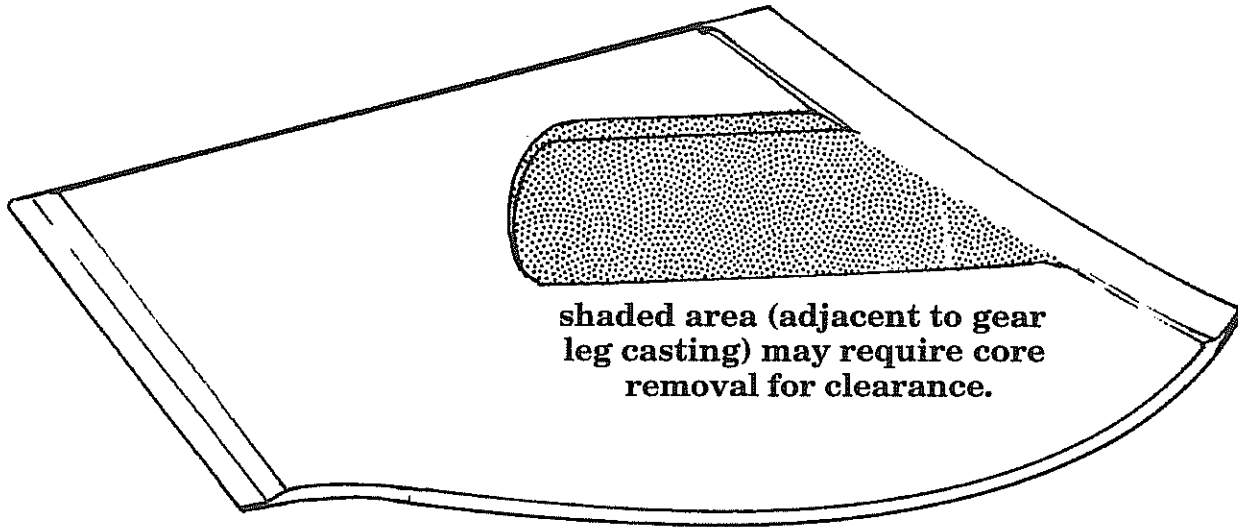

2. From some .090 aluminum, form an attachment bracket similar to that in figure 6-11. This will attach through the upper two landing gear axle bolt locations and extend outward to attach to what will be the lower portion of the middle gear door (if viewed while in the gear down position).
3. Attach this above bracket using the two axle bolts.



Middle gear door

Figure 6-10

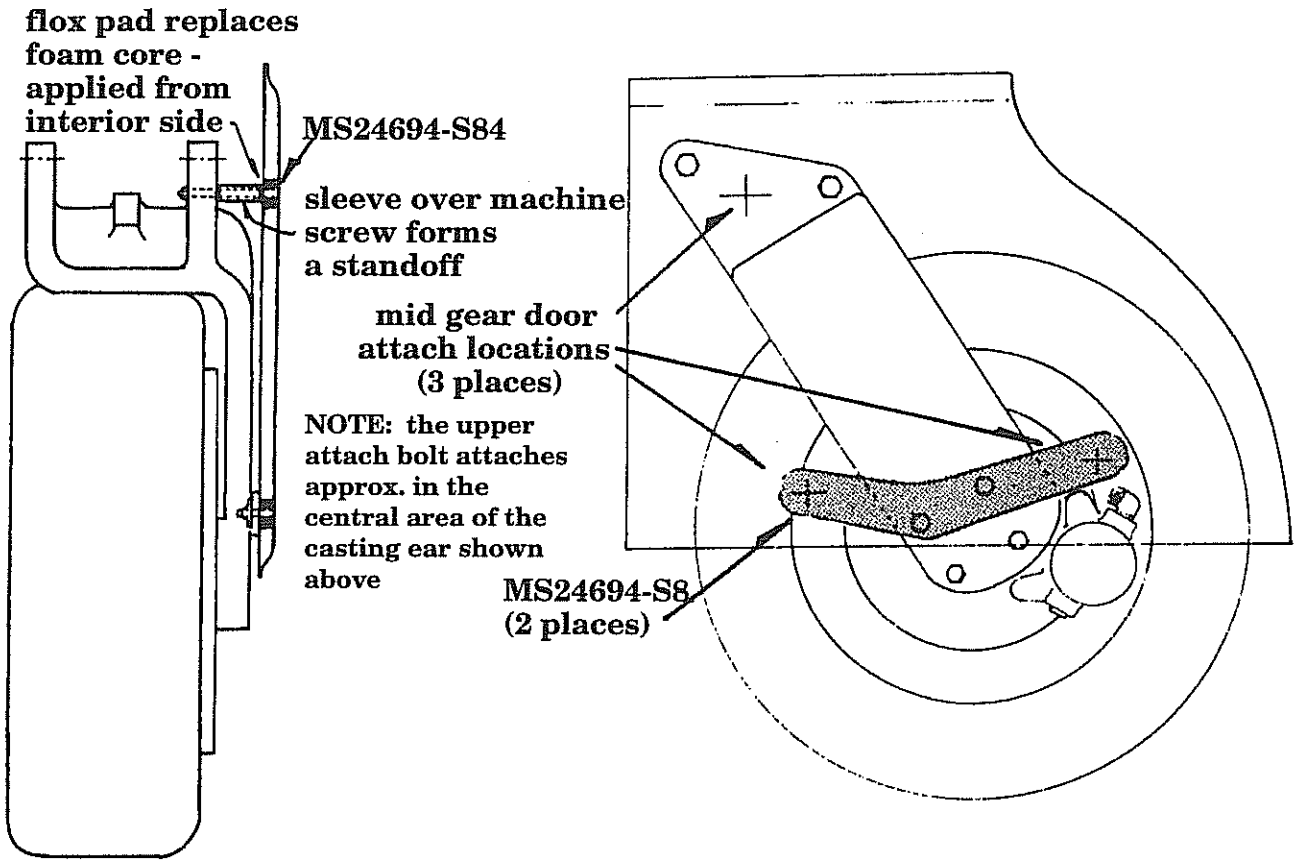

MIDDLE GEAR DOOR - MOUNT BRACKET

Figure 6-11

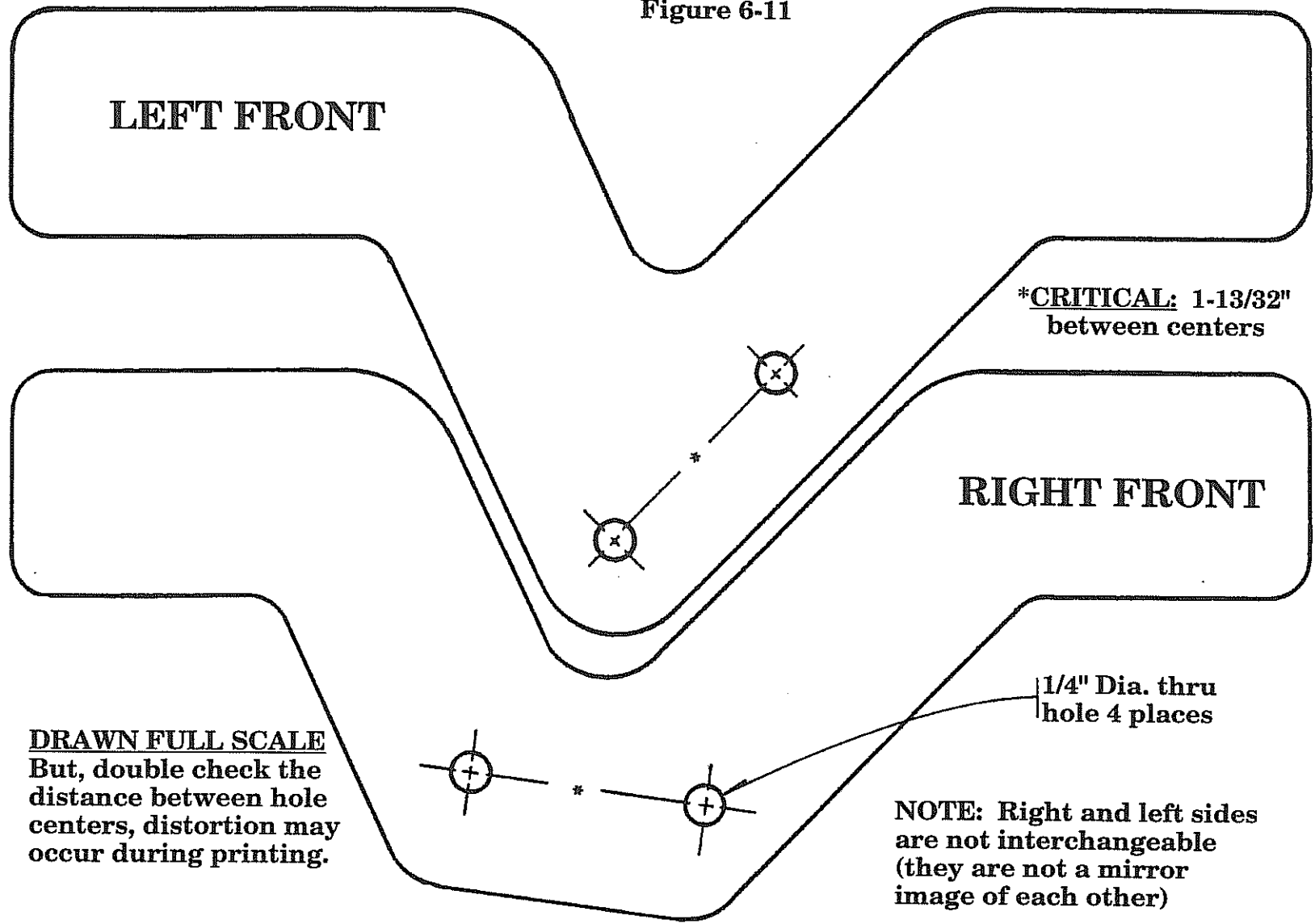

LEFT FRONT

RIGHT FRONT

***CRITICAL: 1-13/32"**
between centers

1/4" Dia. thru
hole 4 places

**NOTE: Right and left sides
are not interchangeable
(they are not a mirror
image of each other)**

DRAWN FULL SCALE
But, double check the
distance between hole
centers, distortion may
occur during printing.



4. With the gear in the retract position, fit the bracket such that there is a small gap at each end between it and the inside of the gear door itself. This may require some slight bending.
5. Sight from the edge to align the attachment hole location and mark this location on the gear door. Refer to step 9, below, for a good method of locating these holes properly.
6. Using a #19 drill bit, drill through the gear door and through the .090 aluminum bracket. Drill one hole at each end.
7. Remove the gear door and attach a nutplate (8-32 size or K1000-08) with two rivets each to the under side of the .090 aluminum bracket.
8. With the door still removed, locate the attach point of the upper bolt per figure 6-10 on the gear leg casting.
9. By laying a straight edge over the gear well and sighting directly down to align with the upper attach point marked on the casting, place a pencil mark on the outer wing skin thus allowing you to relocate the straight edge later. Doing this in two directions will then allow you to establish the same upper attach point on the gear door skin once it is positioned back over the gear (this is similar to finding your navigational position on a flight map by establishing two bearing lines and marking where they intersect one another). This method can be used to locate the other two attachment holes on the lower end with excellent results. Refer to figure 6-12.



Aligning attach point and gear door

Figure 6-12

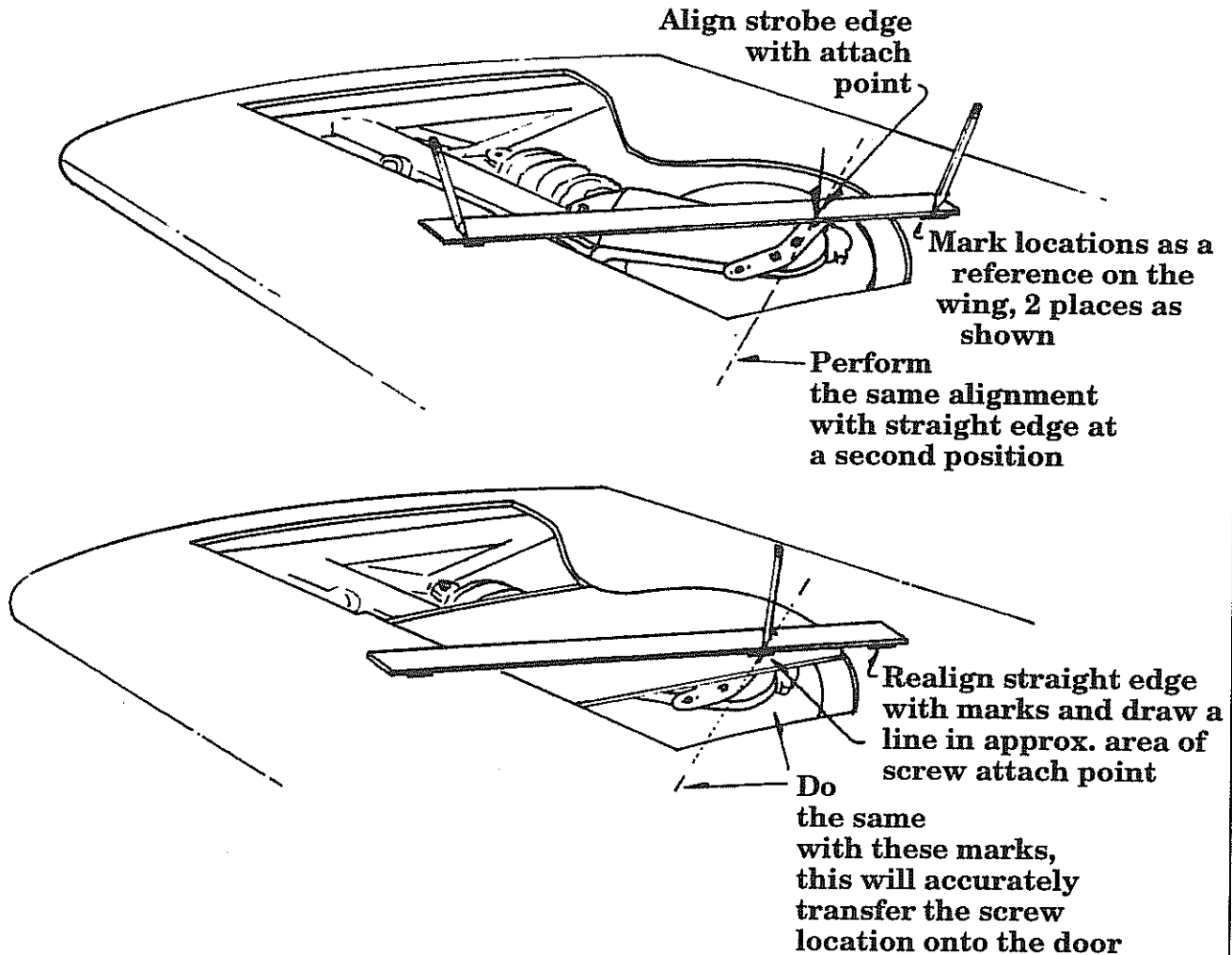

10. Drill through the gear door using a #12 bit and continue drilling through the casting.
11. This attach bolt used on the upper attachment will need to be staked off, establishing the proper position for the middle door. Use a small length of either the 3/8" x .085 steel tubing or the 3/8" x .058 aluminum tubing. You'll only need about 1.75" or less. See figure 6-10.



12. With all the attachment holes drilled into the middle gear door, grind out the foam core material just around the hole area (approx. 3/4" dia. around hole will be enough). Add (very wet) flox to fill this area. After cure, redrill the hole using the same #19 drill. Note that the flox should be added from the inside skin surface of the door, **NOT FROM THE OUTSIDE SURFACE**. The three door attachment holes will all need to be counter sunk (100° typical).
13. Mount the gear door and check for fit.
14. Install the outbd gear door push rod and adjust until it pulls the door down snugly. **DO NOT SET THIS TOO TIGHT JUST YET SINCE THE HYDRAULICS WILL TEND TO PULL THE GEAR (AND THUS THE DOOR) UP EVEN TIGHTER.**



C. Nose gear door

The nose gear door is a simple piece of composite (1/4" core + 2 BID per side). It will measure approximately 7" x 27 3/4". Additional BID will be added for stiffening.

1. From a piece of 1/4" foam cut to the proper shape and lay up 2 BID on what will become the exterior surface.
2. After cure, scarf back the interior edges by 1" and the area where the control horn will attach. See figure 6-14. Add 2 BID over this area with one additional BID along the edges. Add 2 BID over the control horn area bringing this areas ply schedule up to 4 BID on the inside. Once the hinge is fitted, additional BID will be required under the control horn area to bring it flush with the hinge surface (about 3 BID is required).
3. It is best to establish a slight curve into the door such that the aft end contacts the fslg first and thereby generating a preload into the door seal at the aft end. This curvature can be easily established with a high temperature post cure after assembly.
4. A piece of extruded aluminum hinge approx. 20-1/2" long will be fitted into the gear door. This will require reversing the hinge pieces and notching into the gear door, see figure 6-14. Mount to the door with MS24694-S5 machine screws and K1000-08 anchor nuts. Often, due to the tight clearances between wheel and gear door during retract, the ends of the machine screws will require filing down to within one thread of the anchor nut edge. This is only required along the areas where the wheel itself passes.
5. Make and install the control horn per figure 6-14, 6-15, 6-16 and 6-17. Note that a BID patch will be required under the control horn to bring the door surface flush to the hinge half so that the control horn has a smooth flat surface on which to attach. Mount the control horn using two MS24694-S5 machine screws. One will also mount through the hinge.
6. Drill #30 holes (every 1-1/2") for the structural pop rivets that will hold the door onto the fslg. Position the door onto the fslg and instant glue it into position temporarily; check for a good alignment to the fslg. When satisfied, open the door and drill through for the pop rivets. The door may now be attached.
7. To fair the door into the fslg, use micro around the door. Wrap plastic tape around the edges of the door to form a release.
8. To help achieve a good tight seal of the door, the previously described preload is desired. This can easily be established with a heat gun.



9. Using suitable weights, hold the door tight against the fslg at the aft end and fwd end.
10. Next slip about three or four stir sticks between the door and the fslg around the middle point.
11. From the inner side, run a heat gun back and forth along the edges of the door (not by the hinge section though) until it is too hot to hold your hand on. Maintain this temperature for about 5 minutes and allow to cool. This will place a warp into the door which will facilitate a tight seal at the aft end.

NOTE: it is possible to place too much of a warp into the door. To check, see if a 15 lb. weight will push the door shut when placed 5" out from the doors hinge line and perpendicular to the control horn attach position. If it will, then all is good, if it won't then a little preload should be taken out of the door with a similar heat application.

Applying weight to establish preload

Figure 6-13

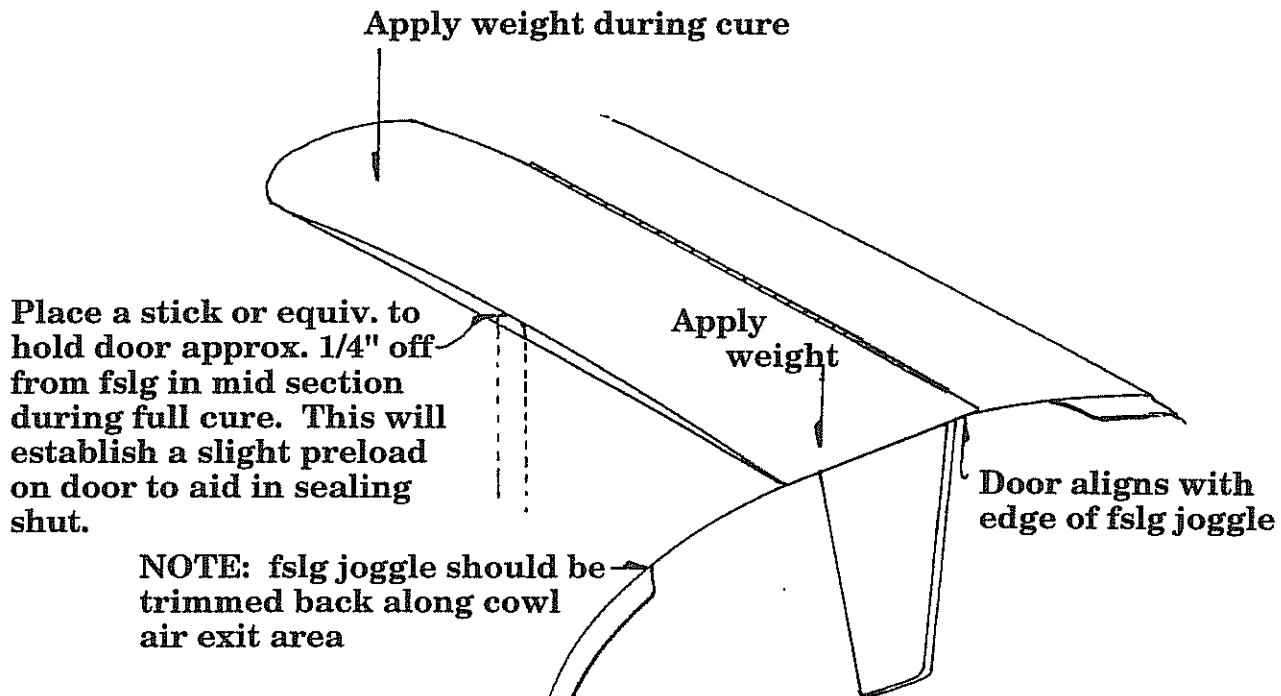

Location of hinge on gear door
Figure 6-14

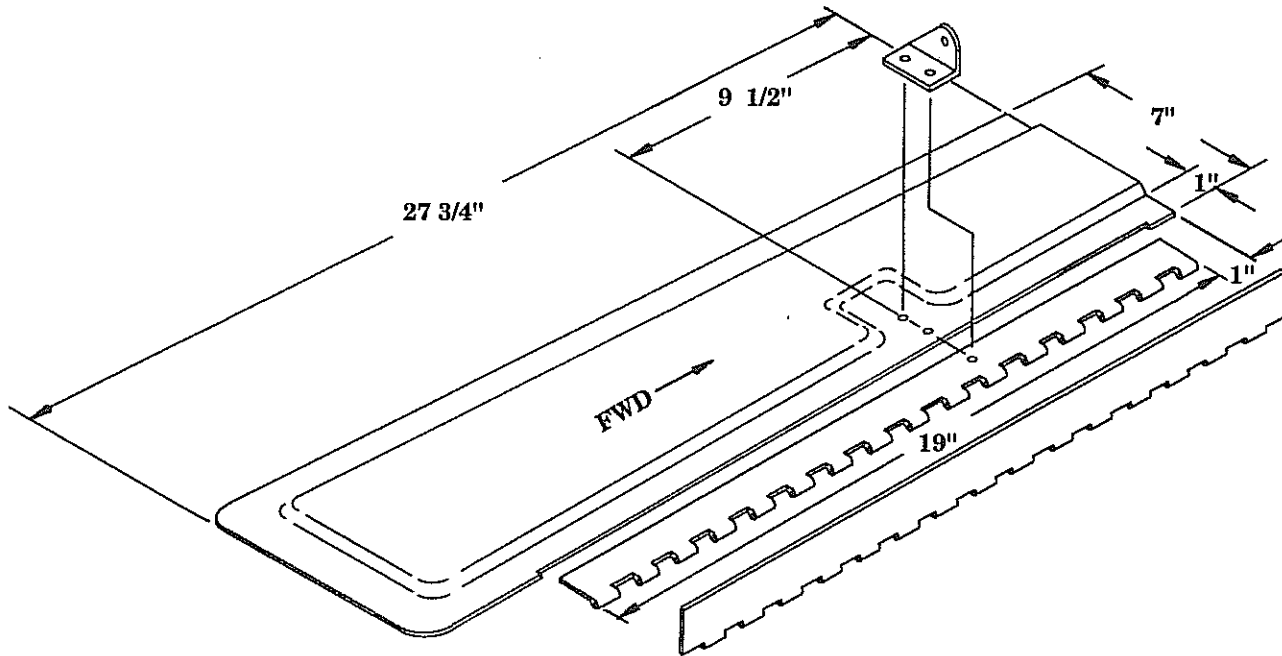

Nose gear door cylinder installation

Figure 6-15

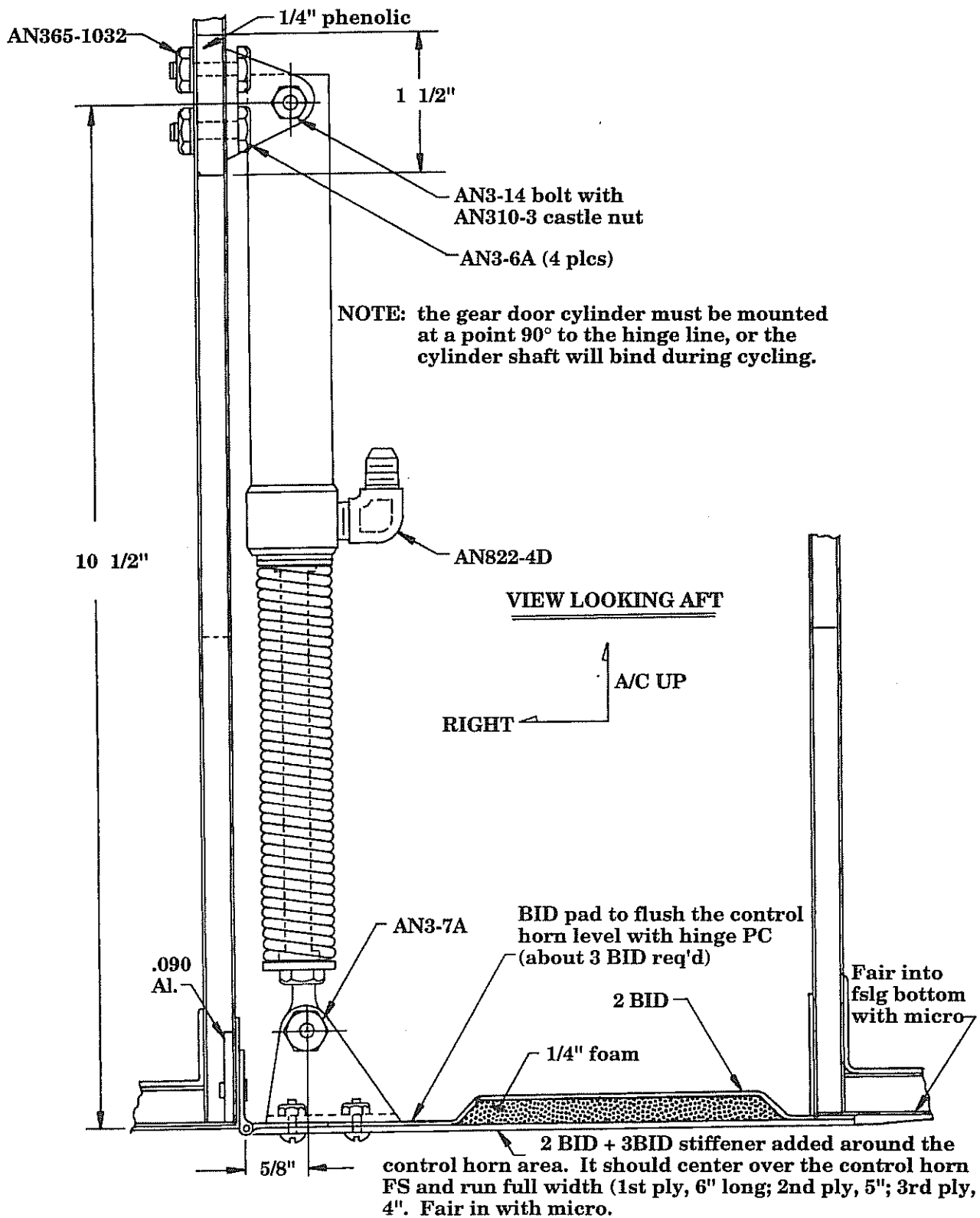

Nose gear door cylinder attach bracket

Figure 6-16

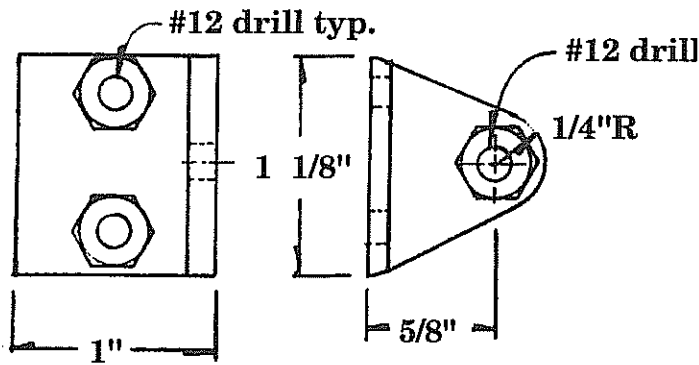

Nose gear door control horn

Figure 6-17

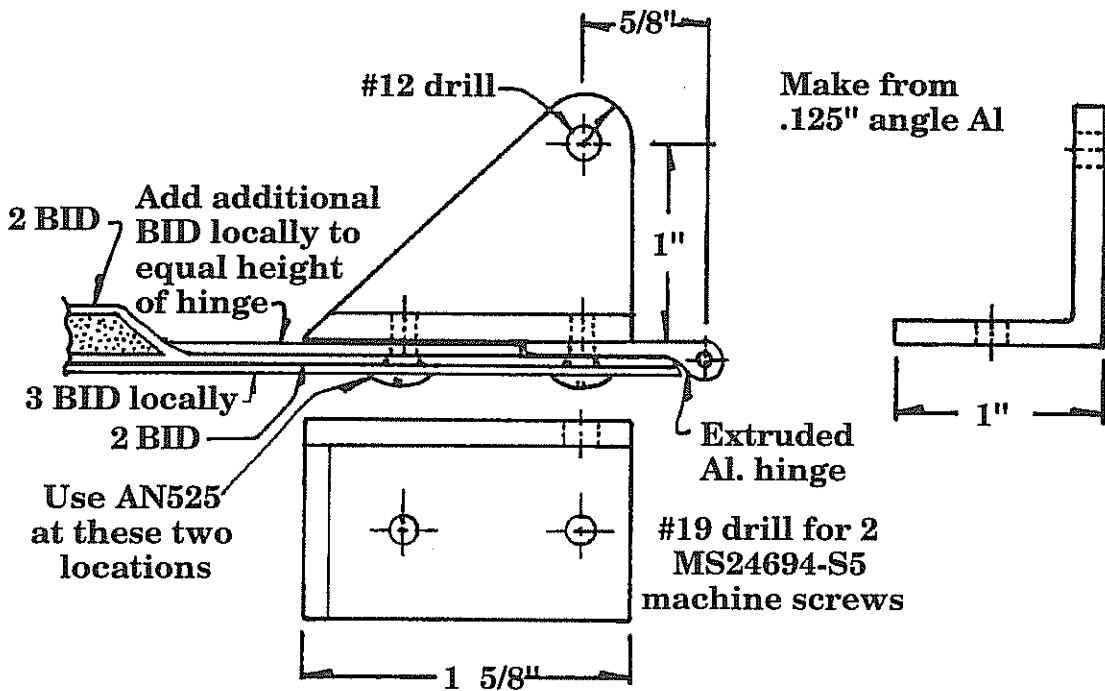

CHAPTER 7

REVISION LIST



The following list of revisions will allow you to update the Lancair 320/360 construction manual chapter listed above.

Under the "Action" column, "R&R" directs you to remove and replace the pages affect by the revision. "Add" directs you to insert the pages shown and "R" to remove the pages.

Page(s) affected	Current Rev.#	Action	Description
7-1 thru 7-12	None		
7-13	A2	R&R	Moved figure to 7-22, removed step B2.
7-14	A2	R&R	Moved B2 & B3 to previous page.
7-15 thru 7-17	None		
7-18	A2	R&R	Re-labeled elevator ribs.
7-19	None		
7-20	A2	R&R	Edited step C2 (#4).
7-21	None		
7-22	A2	R&R	Moved figure from page 7-13.
7-23 thru 7-32	None		
7-33	A2	R&R	Relabled elevator ribs, changed dia. vents
7-34	A2	R&R	Relabled elevator ribs.
7-35 & 7-36	None		
7-37	A2	R&R	Edited text in paragraph below figure
7-38 thru 7-44	None		
7-45	A2	R&R	Added text to figure.
7-46 & 7-47	None		
7-48	A2	R&R	Flipped hinge.
7-49 thru 7-58	None		
7-59	A2	R&R	Added text to step J4.
7-38 thru end	0	None	



CHAPTER 7

HORIZ. STAB AND ELEVATOR

REVISIONS

From time to time, revisions to this assembly manual may be deemed necessary. When such revisions are made, you should immediately replace all outdated pages with the revised pages. Discard the out dated pages. Note that on the lower right corner of each page is a "revision date". Initial printings will have the number "0" printed and the printing date. All subsequent revisions will have the revision number followed by the date of that revision. When such revisions are made, a "table of revisions" page will also be issued. This page (or pages) should be inserted in front of the opening page (this page) of each affected chapter. A new "table of revisions" page will accompany any revision made to a chapter.

Arrows

Most drawings will have arrows to show which direction the parts are facing, unless the drawing itself makes that very obvious. "A/C UP" refers to the direction that would be up if the part were installed in a plane sitting in the upright position. In most cases the part shown will be oriented in the same position as the part itself will be placed during that particular assembly step. However, time goes on and changes are made, so careful attention should be paid to the orientation arrows. That old cartoon of the guy agonizing over the plans for his canoe, built one end up, one end down, should not happen in real life. Especially to you.



7-1

Chapter 7	REV.	0/05-10-98
Horizontal Stab and Elevator		

CONTENTS

1. INTRODUCTION
2. SPECIAL TOOLS AND SUPPLIES LISTS
3. CONSTRUCTION PROCEDURE
 - A. H. STAB ASSEMBLY CRADLE
 - B. H. STAB HINGE BRACKETS
 - C. ELEVATOR HINGE INSTALLATION
 - D. TRIM MOTOR INSPECTION PANEL
 - E. COUNTERBALANCING THE ELEVATORS
 - F. CLOSING THE H. STAB AND ELEVATORS
 - G. MAC SERVO AND STANDARD TRIM TAB
 - H. ELEVATOR TRAVEL STOPS
 - I. HORIZONTAL STAB MOUNTING AND BULKHEAD
 - J. VERTICAL STABILIZER SPAR
 - K. HORIZONTAL STABILIZER FORWARD BULKHEAD
 - L. HORIZONTAL STABILIZER MIDDLE BULKHEAD
 - M. HORIZONTAL STABILIZER FINAL BOND TO FUSELAGE





1. INTRODUCTION

The horizontal stabilizer (H. Stab.) is comprised of two structural skins (top and bottom), and an internal structure consisting of spars and ribs. This is a symmetrical airfoil so top and bottom are the same. You'll notice that there is a 1" L.E. joggle that does make the two halves look different. The half that has the wrap around L.E. with joggle is the half that must be first laid into the assembly cradle that you'll be making and for the sake of discussion, we will call this half the bottom skin.

The H. Stab. is also tapered, which means that the thickness will vary. The thickest part is at the center line and the thinnest is at the tip. A straight line will exist from any relative % of chord at the root to the same % of chord at the tip. For example, the points along the 25% chord will form a straight line along the entire airfoil. With this fully symmetrical stabilizer, either the upper or the lower skin will be flat (spanwise) from tip to tip.

The elevator consists of a left and right half. The internal structure is completed except for the installation of the trim tab and the counterweights.



2. SPECIAL PARTS, TOOLS, AND SUPPLIES LISTS

A. PARTS

#	P/N	QTY	DESCRIPTION
1)	5-010025	1	Upper H. Stab. Skin
2)	5-010010	1	Lower H. Stab. Skin with Premolded Structure
3)	EL053-T	5	H. Stab. Hinges
(Not shown: (20) K1000-3 nutplates and (40) AN426A3-4, (20) AN3-6A bolts, and (20) AN960-10 washers used to secure the hinges to the H. Stab.)			
4)	5-020075	1	Upper Left Elevator Skin
5)	5-020085	1	Upper Right Elevator Skin
6)	5-020050	1	Lower Left Elevator Skin with Premolded Structure
7)	5-020060	1	Lower Right Elevator Structure with Premolded Structure
8)	EL-055-02	1	Elevator Weldment
Note: refer to the following figure for mounting hardware			
9)	EL-053-U	4	Elevator Hinges (Elevator)
(Not shown: (8) K1000-3 nutplates and (40) AN426A3-4 rivets, (8) AN3-5A bolts, and (20) AN960-10 washers used to secure hinges to elevator.			
10)	5-020096	2	Premolded Counterweights
11)	S4A	1	Trim Tab Servo
(Not shown: (5) MS24693-S28 screws, (5) K2000-06 nutplates, and (10) AN426A3-4 rivets to secure it)			
12)	5-020016	1	Trim Tab Cover
13)	5-002045	1	Upper Trim Tab Skin
14)	5-020035	1	Lower Trim Tab Skin
15)	MS20001	2	Trim Tab Hinge
(Not shown: Trim tab activator arm, (4) hard rivets to secure it.)			

Horizontal Stabilizer Breakdown

Fig. S 2-1.

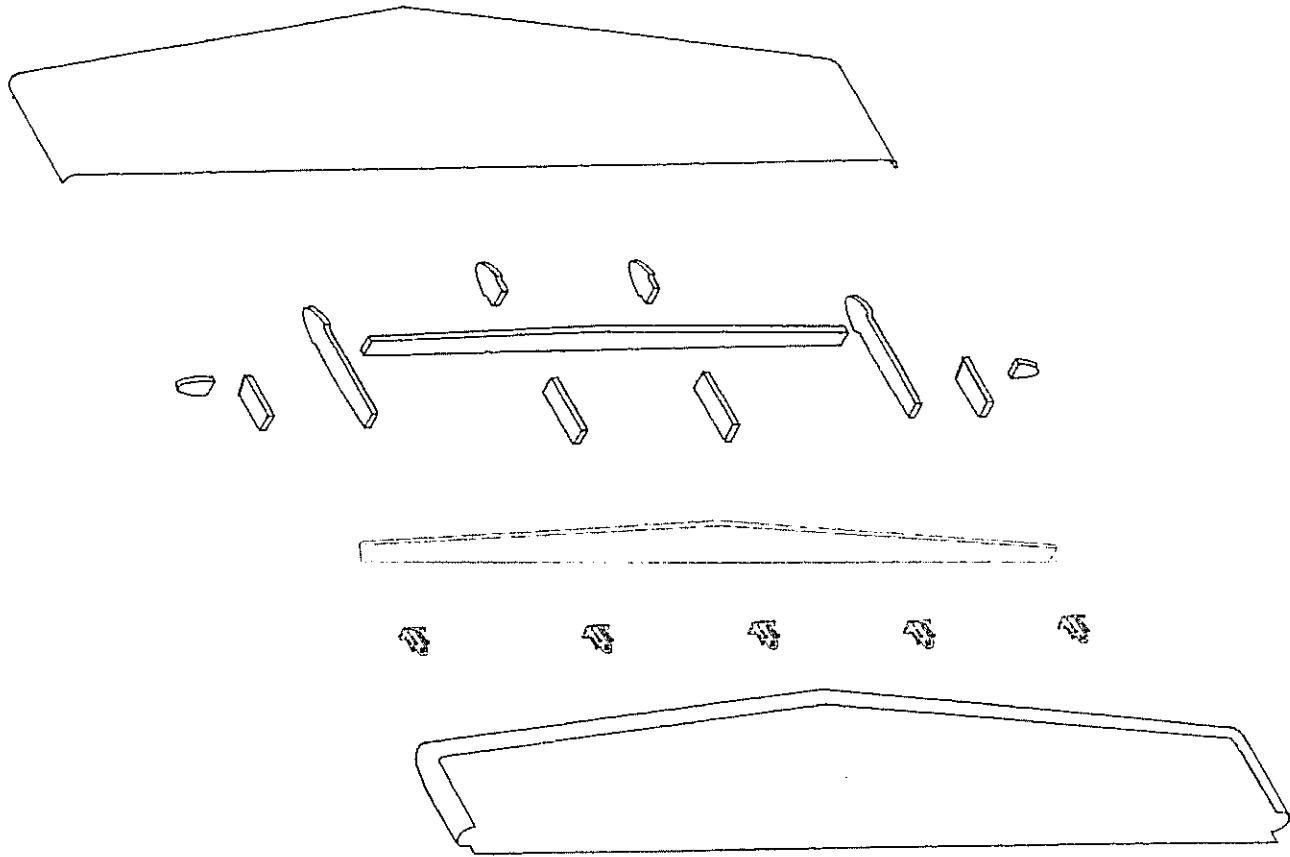

B. TOOLS

- 1 Rivet squeezer or bucking bar
- a/r Shot bags (10 lbs. - 25 lbs. assorted weights are great)
- 1 Sabre or band saw
- 1 Level, flat table top, approximately 11' long and 30-36" wide
- a/r nails or wood screws
- 1 hammer or screwdriver
- 1 6' level
- 1 Drill motor
- 1 Drill bit, 1/8"
- 1 Drill bit, #12
- 1 Drill bit, #40
- 1 100° countersink
- 1 Cleco tool and about a dozen Clecoes (a real handy tool for this project, but not mandatory).
- 1 Dremel tool with a ball grinder bit
- 1 Heat gun
- 1 Roller blade cutter (Looks like a Pizza cutter, but a pizza cutter WILL NOT WORK), available through Lancair.
- 1 set Bondo™ Plastic spreader set- available from auto parts stores, contains 3 spreaders of varying sizes.
- 1 3" wide roller for wetting out BID tapes. Metal ones are easiest to clean.



C. SUPPLIES

- 130 #6 x 3/8" pan head sheet metal screws
- 10 1" x 2" x 6' wood strips (straight) for cradle
- a/r Instant glue
- 5 pcs. of wood (about 3" x 3" x 1/2") to brace aft spar during bonding
- a/r Release tape (clear, thin packaging tape, 2" or 3" wide is good)
- a/r Artist's spray adhesive or similar
- a/r Wood glue
- a/r Bondo™
- 1 Plastic spreader (for the Bondo™)
- a/r Nails or wood screws for fabrication of cradles
- a/r Sandpaper, #40 grit
- 1 Red felt tip marking pen
- a/r MC (Methylene Chloride) cleaner
- a/r Hysol structural adhesive
- a/r Tongue depressors/ mixing sticks
- a/r Acetone (a one pint can from the hardware store should see you through the whole aircraft construction, if used sparingly)

- a/r Microballoons
- a/r Flox
- a/r Epoxy
- a/r Plastic sheet for preparing BID tapes (2 or 3 mil thick (maximum 3 mil)) painter's drop cloths work great.

- 1 Tape measure
- 1 pcs. 10-1/2" x 34" for BL0 cradle
- 2 pcs. 10-1/2" x 29-1/2" for BL 21 cradle
- 2 pcs. 10-1/2" x 24-1/2" for BL 46.75 cradle
- 6 pcs. 50" 1-1/2" x 2" x 1/8" (thick) 90° angle iron
- 2 pcs. 21" 1-1/2" x 2" x 1/8" (thick) 90° angle iron

3. CONSTRUCTION PROCEDURE

A. BUILDING THE H. STAB ASSEMBLY CRADLE

The assembly cradle is needed to insure that a "true" H. Stab. with no twists or warps is the result of your work. You'll make the simple airfoil section cradles that must be aligned with each other. Using a level, flat table top is ideal, but not essential. What is essential is that the chord line references on the airfoil cradles be properly aligned with each other and that good straight lines be established between these three airfoil section cradles.

H. Stab. Cradle Patterns

Fig. 7:A:1.

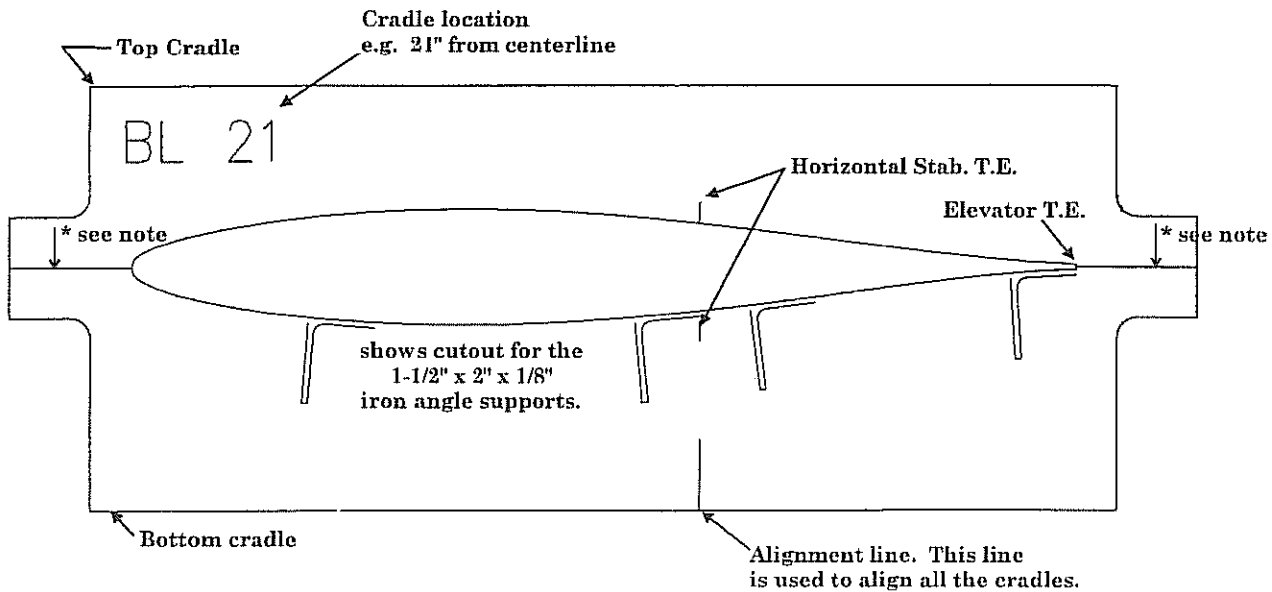

* Note: This tab should be in the same level (horizontal) plane for all cradles.



- A1. Locate the three patterns for the H. Stab airfoil sections- blueprint numbers 5-020101, 5-020111, and 5-020121. You'll be making two of the BL 21 and BL 46.75 cradles and one from the root pattern. Using spray adhesive or similar, glue them to the 1/2" thick particle board. You've been supplied with two copies of this blueprint so that one copy can always remain intact as a reference. At this time check the blueprints for scale:

Chord lengths

Station	Chord length	Tolerance
BL0	28.00	± 1/8"
BL21	23.55	± 1/8"
BL 46.75	18.00	± 1/8"

- A2. Cut the patterns out using a sabre or band saw. Cut just along the inside of the line and then sand up to it.

MK-II H. Stab. Table

Fig. 7:A:2.

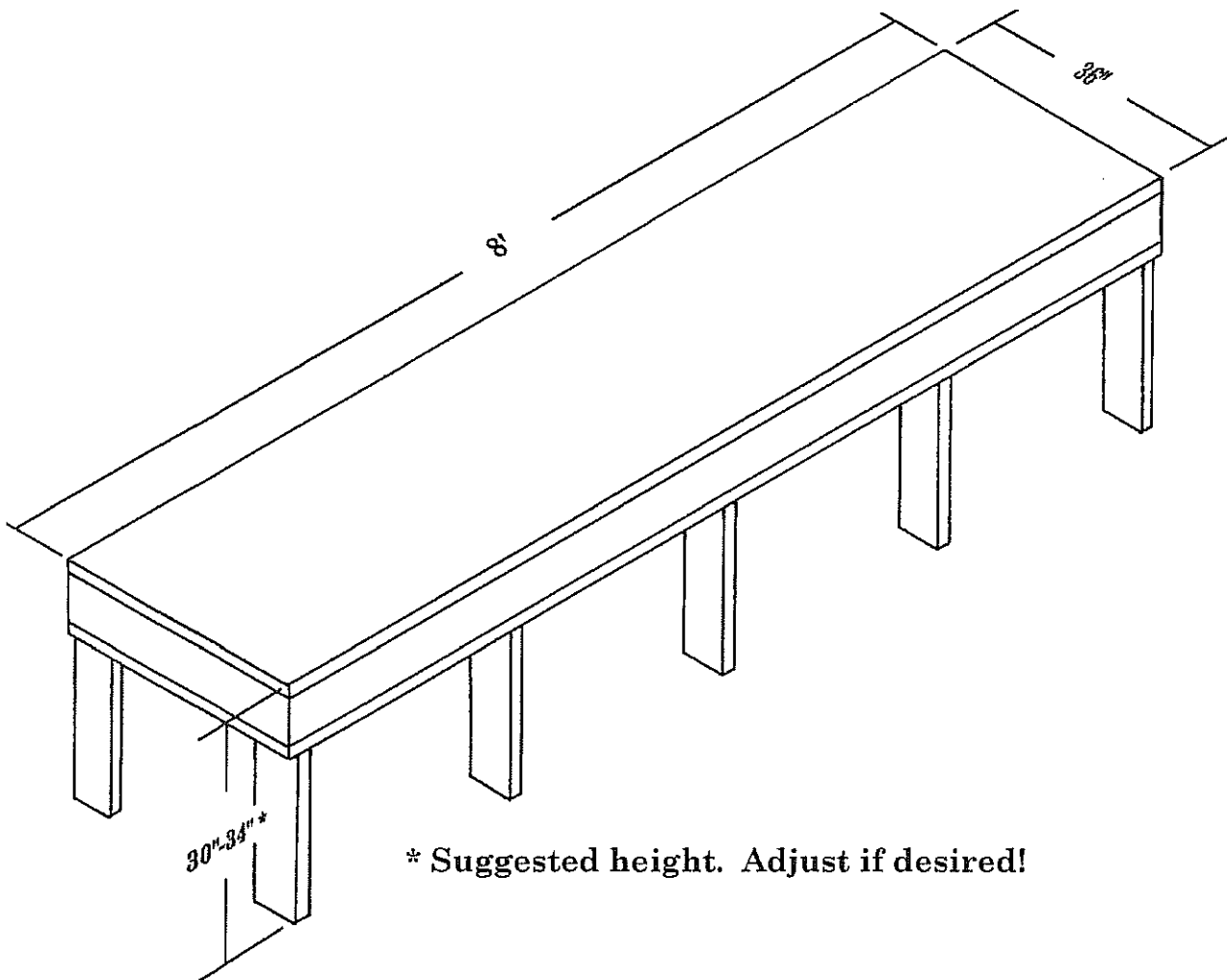

* Suggested height. Adjust if desired!



- A3. Construct a table for your jig. We suggest a box-frame structure as shown in the above figure.
- A4. Draw a straight line 14" from the aft end of the table. Draw perpendicular lines to this at BL 0, BL 21, and BL 46.75 (the cradles will be centered on these lines).

Installing the Support Braces

Fig. 7:A:3

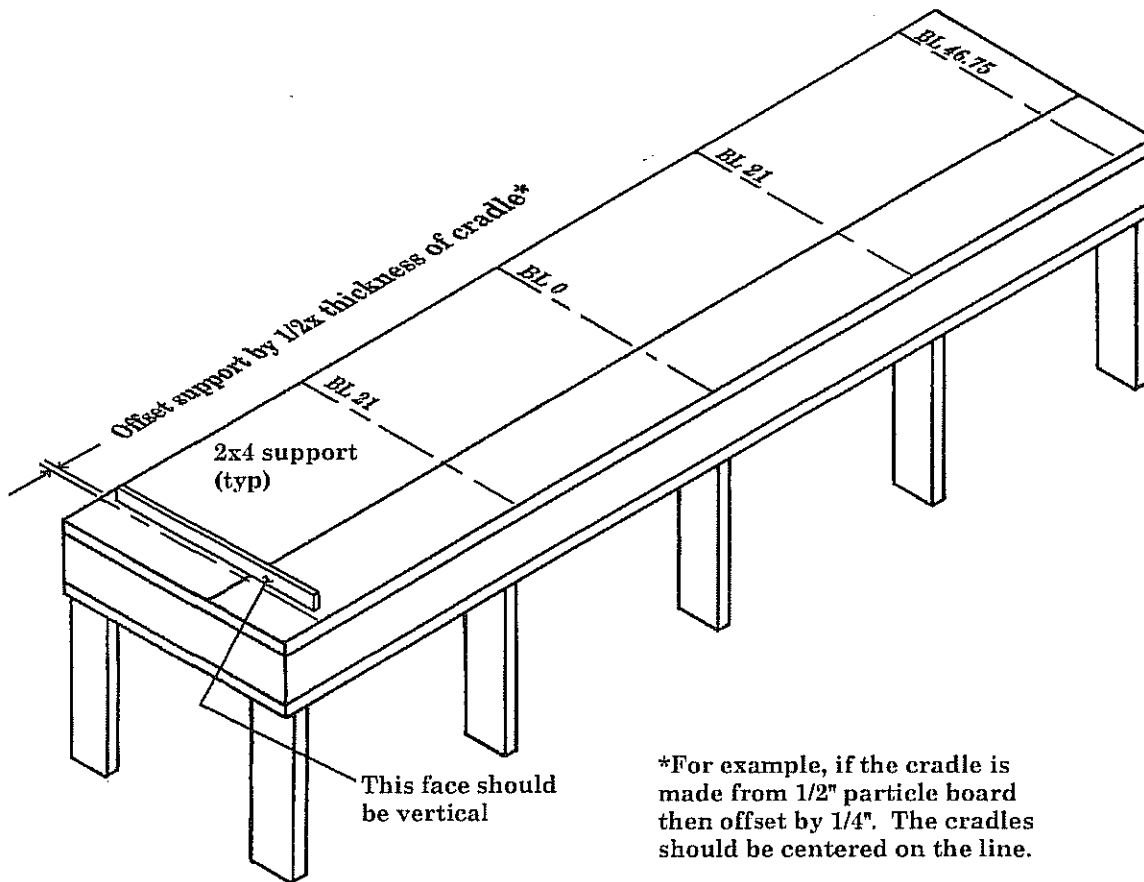

- A5. Install the cradle supports. Use 2 x 4's or equivalent. Screw to table.

Leveling the Cradles

Fig. 7:A:4.

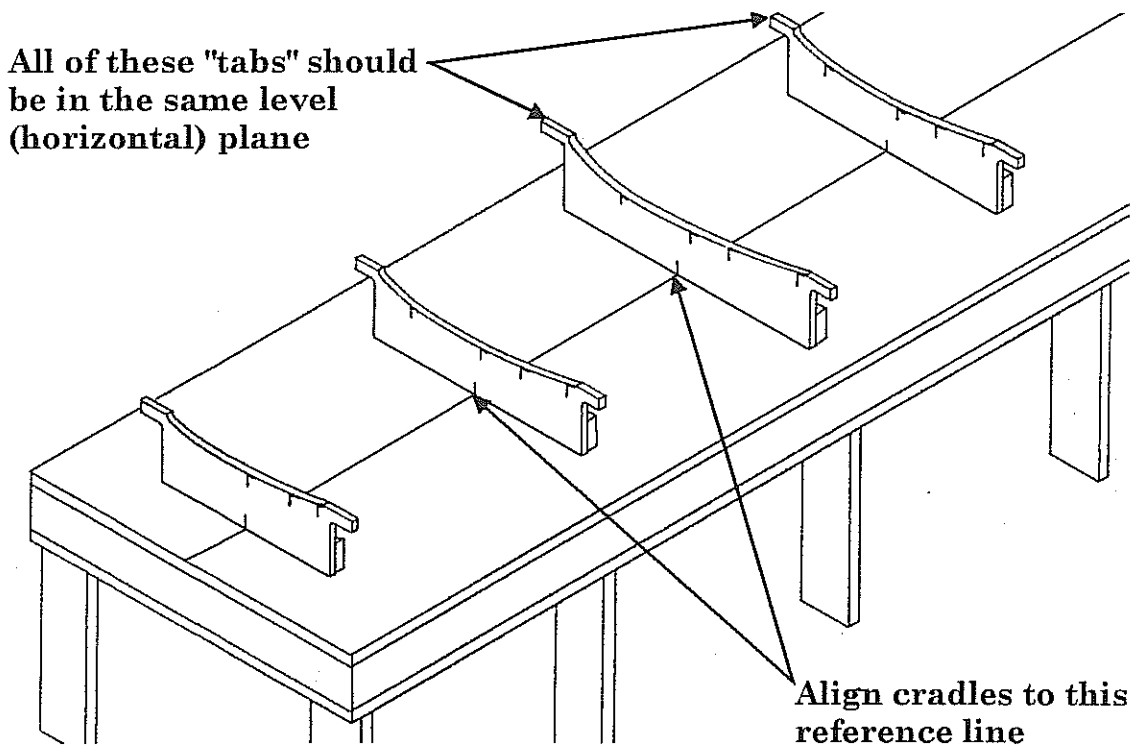

- A6. Install and align cradles. Following is the criteria for aligning cradles:
1. Align fore/aft by using the alignment mark on all the cradles.
 2. All cradles should be set heightwise by leveling the tabs to the same horizontal plane- see figure A1. We suggest using a water level for this step.
- Hint: Start by placing a shim underneath all the cradles- this allows you to bring cradles down as necessary to align.
- A7. Once level, secure all the cradles to the cradle supports with wood screws.

Installing the Angle Iron

Fig. 7:A:5.

Install the 1-1/2" x 2" x 1/8"
angle iron as shown

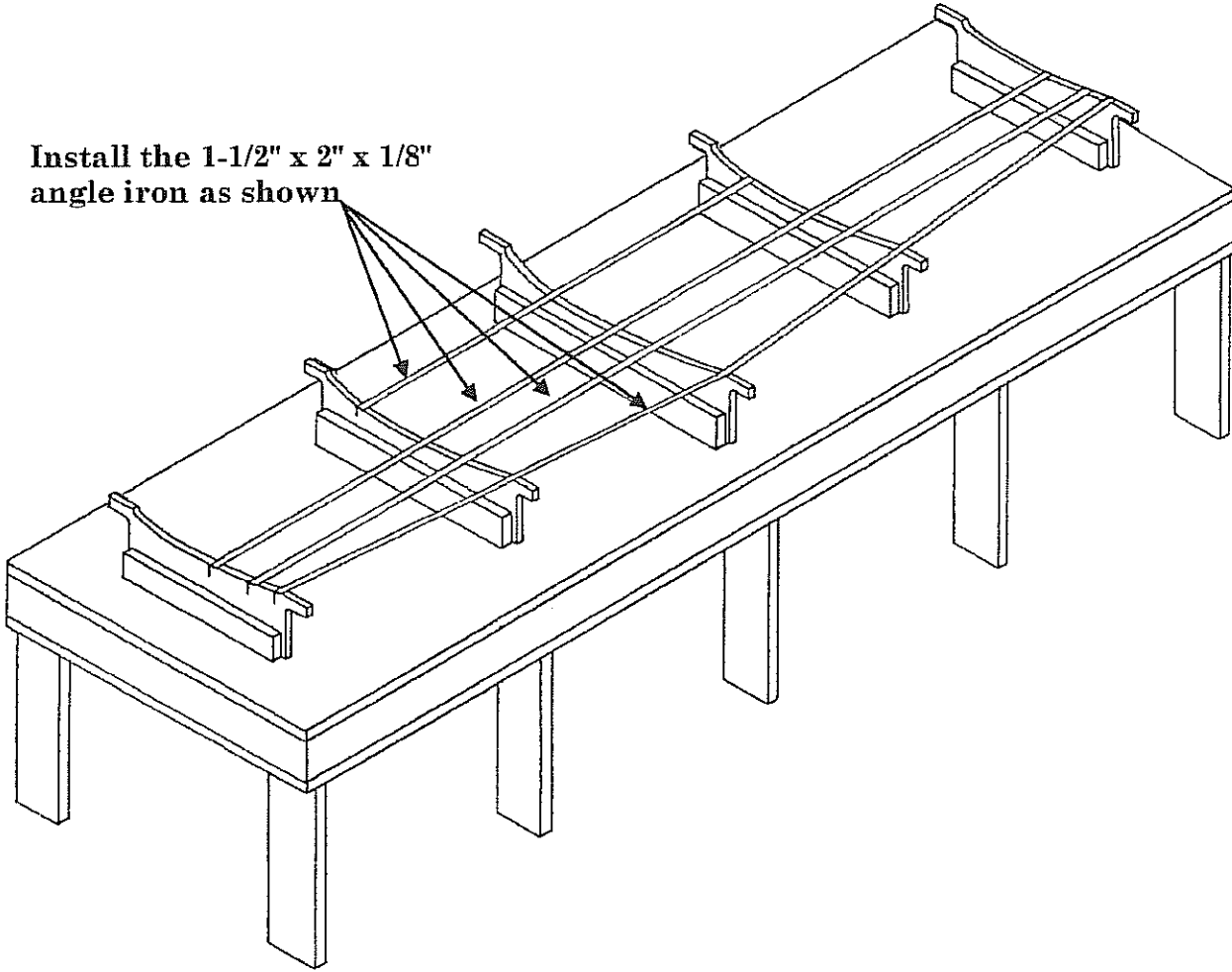



B. H. STAB. HINGE BRACKETS

With the cradle complete, you can now begin building the H. Stab. The first step is to position the H. Stab. in the cradle.

B1. Position the H. Stab. in the cradle.

In summary:

1. The H. Stab. should be centered.

2. The H. Stab. should be pushed forward and fit well in the cradles. Look underneath to check the fit. It is acceptable to use some weight in order to conform the H. Stab. to the cradle.

B2. This step has been eliminated.

B3. Now use Bondo or similar to temporarily secure the H. Stab to the cradles. Use 25lb. shot bags to help hold the stab down in the cradle and eliminate any warping.



7-13

Chapter 7	REV.	A2/04-1-99
Horizontal Stab and Elevator		

Horizontal Stabilizer Top View

Fig. 7:B:2.

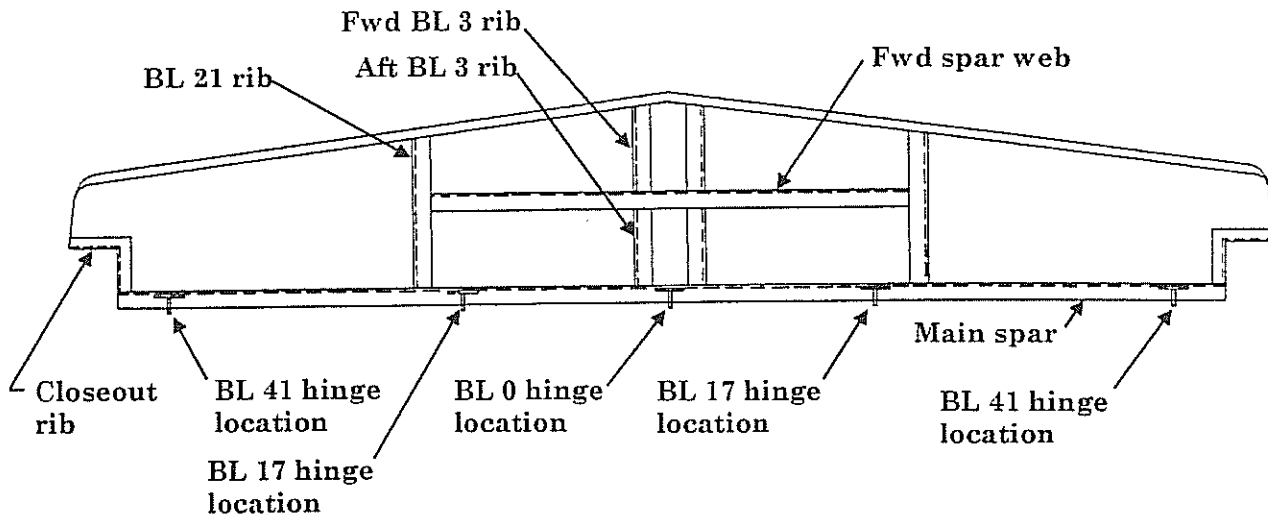

- B4. Remove all peelply from the inner surfaces of both upper and lower H. Stab. skins. Be sure all of it is removed (most of it probably already is).

WARNING: Structural bonds can NOT be made over peelply. Be sure to remove all peelply from bonding areas. Failure to do so will result in structural failure of the component.

Checking Hinge Alignment

Fig. 7:B:3.

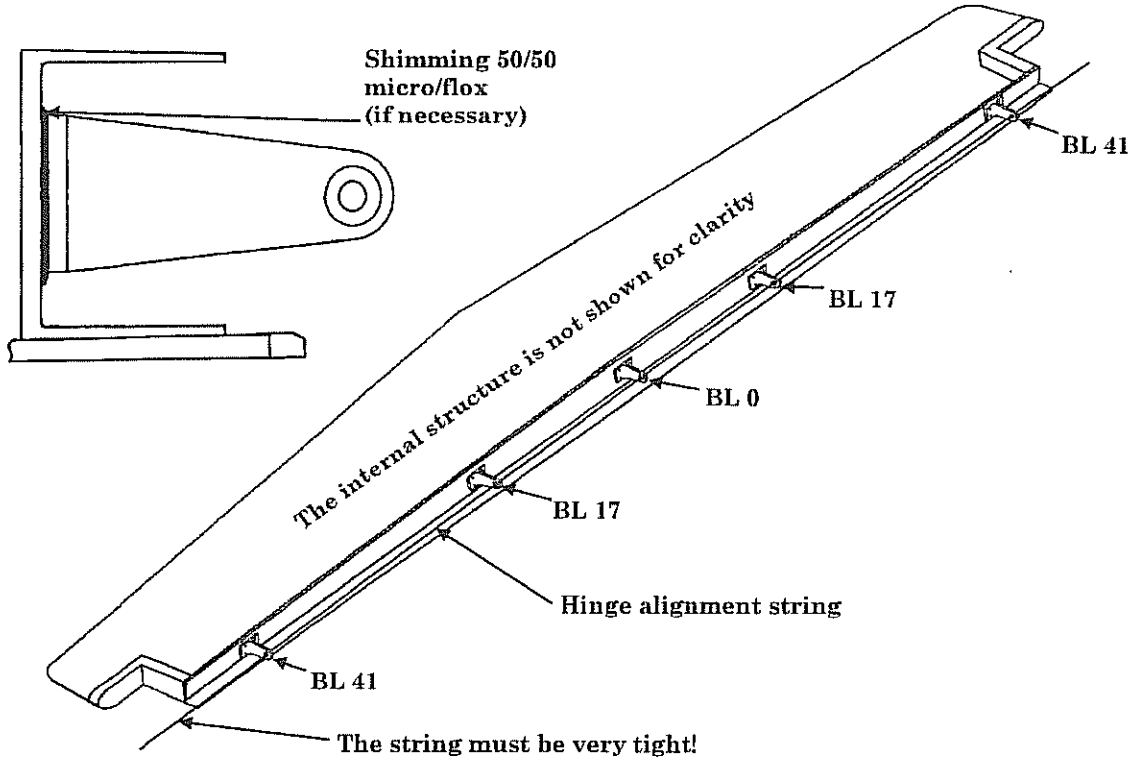

Holding String With Tongue Depressor

Fig. 7:B:4.

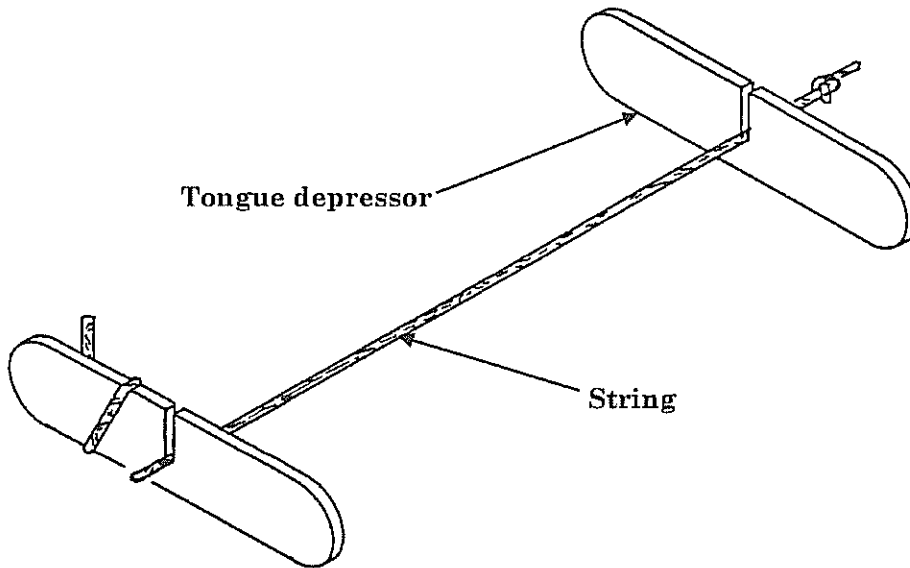



- B5. The hinges must all be centered between top and bottom aft stab skins. They can be clamped or super glued in place. Pull a string through the center of the bearings. The string should be centered on the outboard bearings and must be tight. Perhaps the easiest way to hold the string in place is to use a tongue depressor with a small slot cut into the side. Tie a knot in the end of the string and slide the string through the slot.

The best way of making small adjustments away from the web is to apply a layer of micro/flox (use about 50/50 micro and flox) between web and bracket (see Fig. 7:B:3.). Be sure to apply enough layers of release tape to the hinges to simulate the 3 BID that will be applied to the web after closeout. You'll have to allow this to cure before rechecking the alignments.

- B6. With the hinge brackets properly aligned, drill the pilot holes for the four attach bolts in each bracket. This is a 1/8" pilot hole. You can then use Clecoes to hold the brackets in position.

With the pilot holes drilled first (instead of just going for the final size hole right away), you will have one last opportunity to make any small adjustments in the bracket placements to assure bearing concentricity.

- B7. Now, when you are convinced that everything lines up, go ahead and drill for the attach bolts. Pull out only one Cleco at a time and drill for the bolt hole final size. Use a #12 drill bit and try to make the holes as straight as possible with the hand drill.

Provided that your bolt holes through the fiberglass spar web are nice and clean (not wobbled out), you can use them alone to align the anchor nuts.

If, however, your holes are a bit loose (but they really shouldn't be), you could simply leave the hinge brackets on the web and screw the anchor nuts on, then back drill for each anchor nut's two attach rivets using a #40 drill bit. This will assure a perfect alignment of the bolts and, most importantly, the hinge brackets. If you choose to use this approach, be very careful not to drill into the hinge brackets themselves. A very small drill "tip" divot in the back of the hinge bracket is, however, acceptable.

- B8. Install the nutplates for the hinges.
Method #1.

Method number one requires a bucking bar and a pneumatic rivet squeezer. With this method the rivets are secured directly to the spar. Using the existing 3/16" holes in the spar set the nutplate. Use the nutplate as a guide to drill the #40 holes for the rivets.



Installing the Nutplates, Method #1.

Fig. 7:B:5.

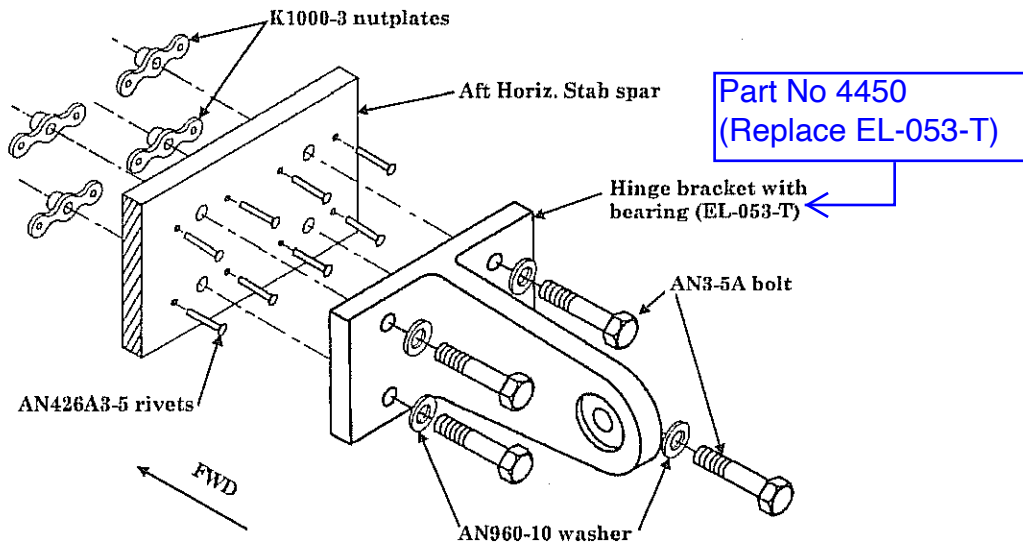

Method #2.

Method number two does not require any special tools other than a rivet squeezer. First lay up a six BID on a flat surface and let cure. Mount the nutplates on the 6 BID and bond the 6 BID in place.

Installing the Nutplates, Method #2.

Fig. 7:B:6.

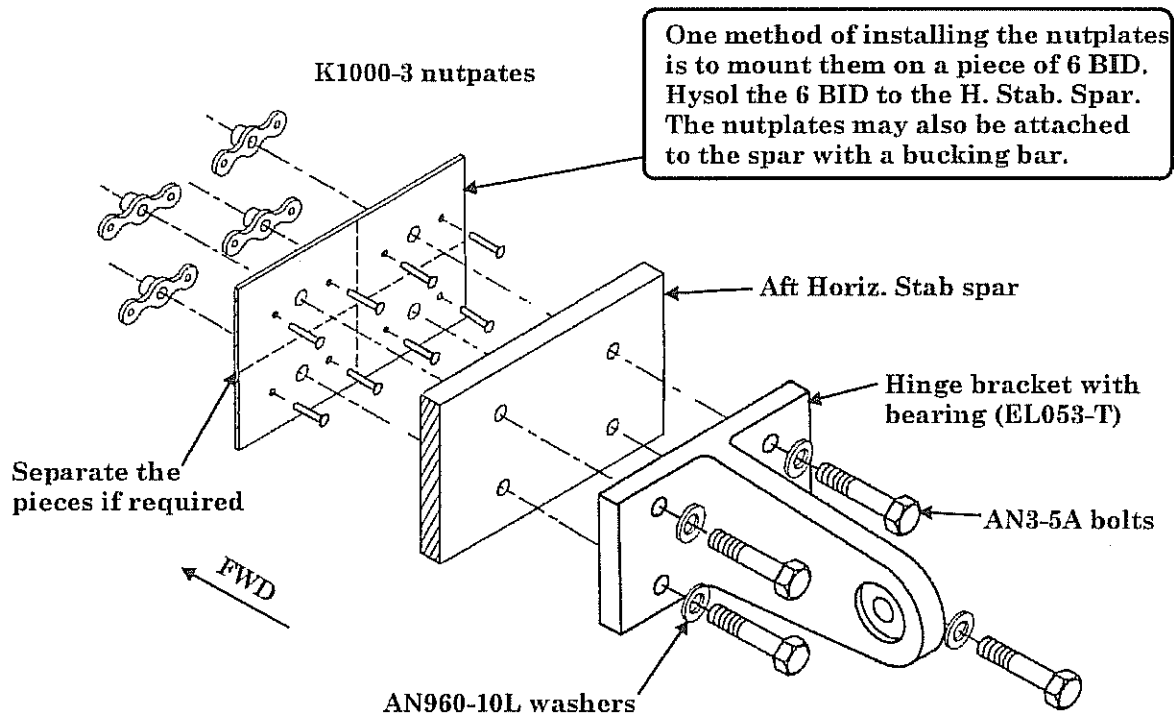

C. ELEVATOR HINGE INSTALLATION

The hinge halves that install into the H. Stab must be installed to set the elevators.
The elevator weldment should also be installed for this step.

Top View, Elevator/ Horizontal Stabilizer

Fig. 7:C:1.

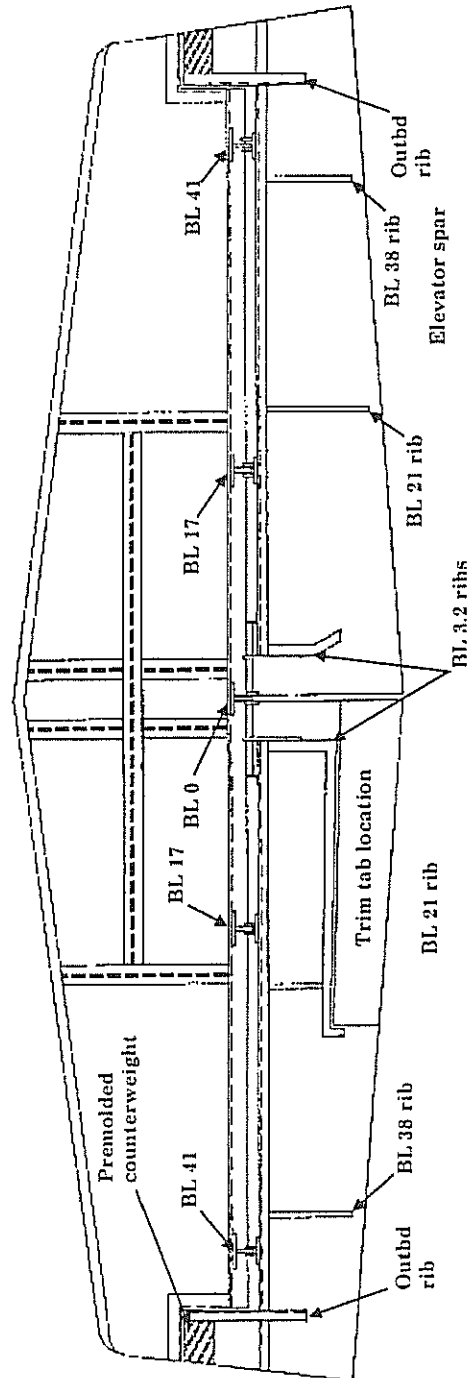

Elevator Hinge Weldment

Fig. 7:C:2.

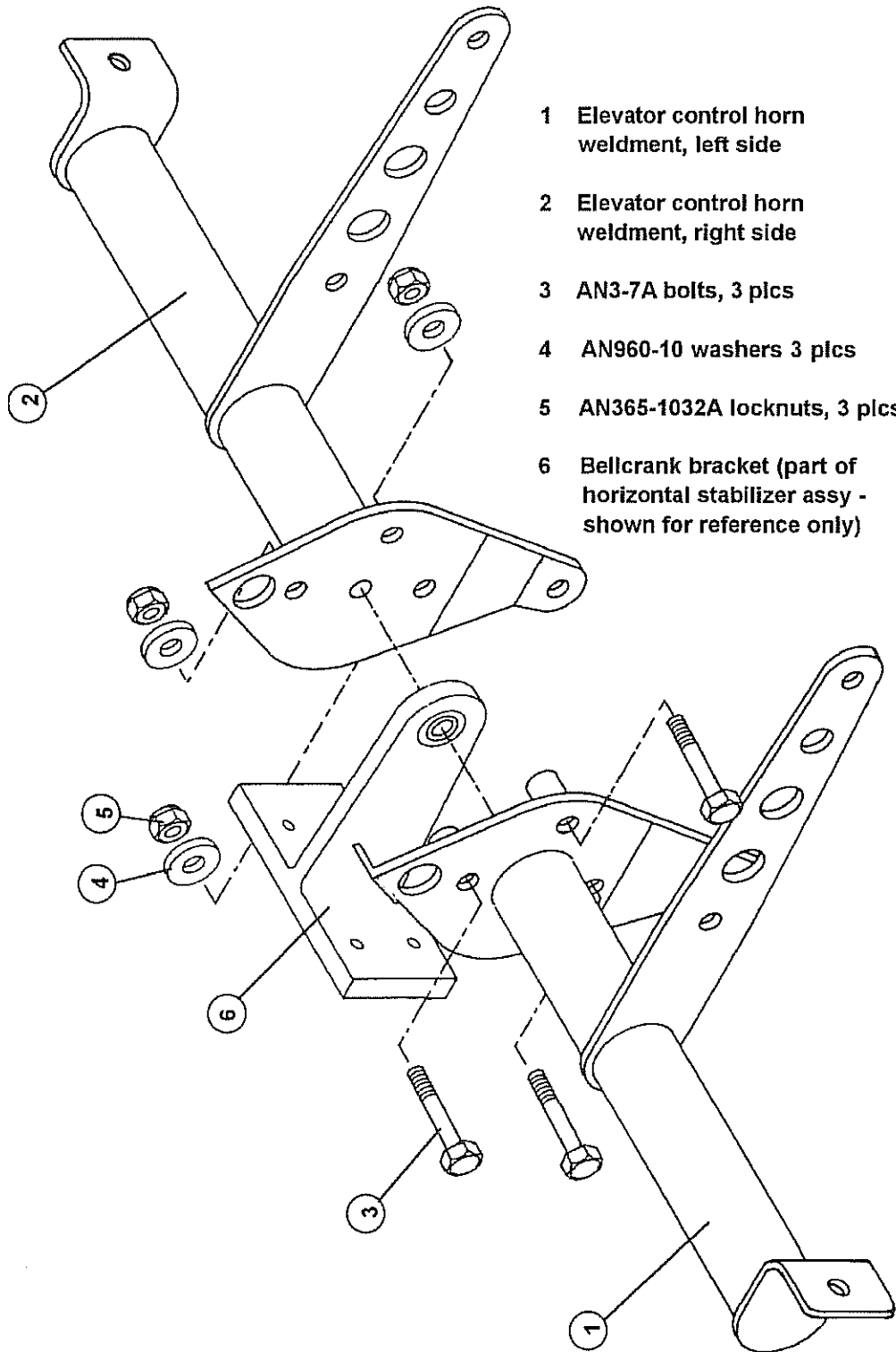

- 1 Elevator control horn weldment, left side
- 2 Elevator control horn weldment, right side
- 3 AN3-7A bolts, 3 pics
- 4 AN960-10 washers 3 pics
- 5 AN365-1032A locknuts, 3 pics
- 6 Bellcrank bracket (part of horizontal stabilizer assy - shown for reference only)

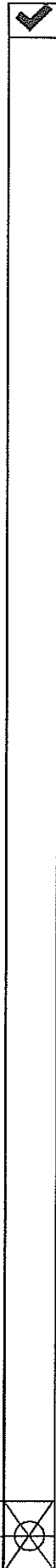

Center Elevator Hinge Weldment

Fig. 7:C:3.

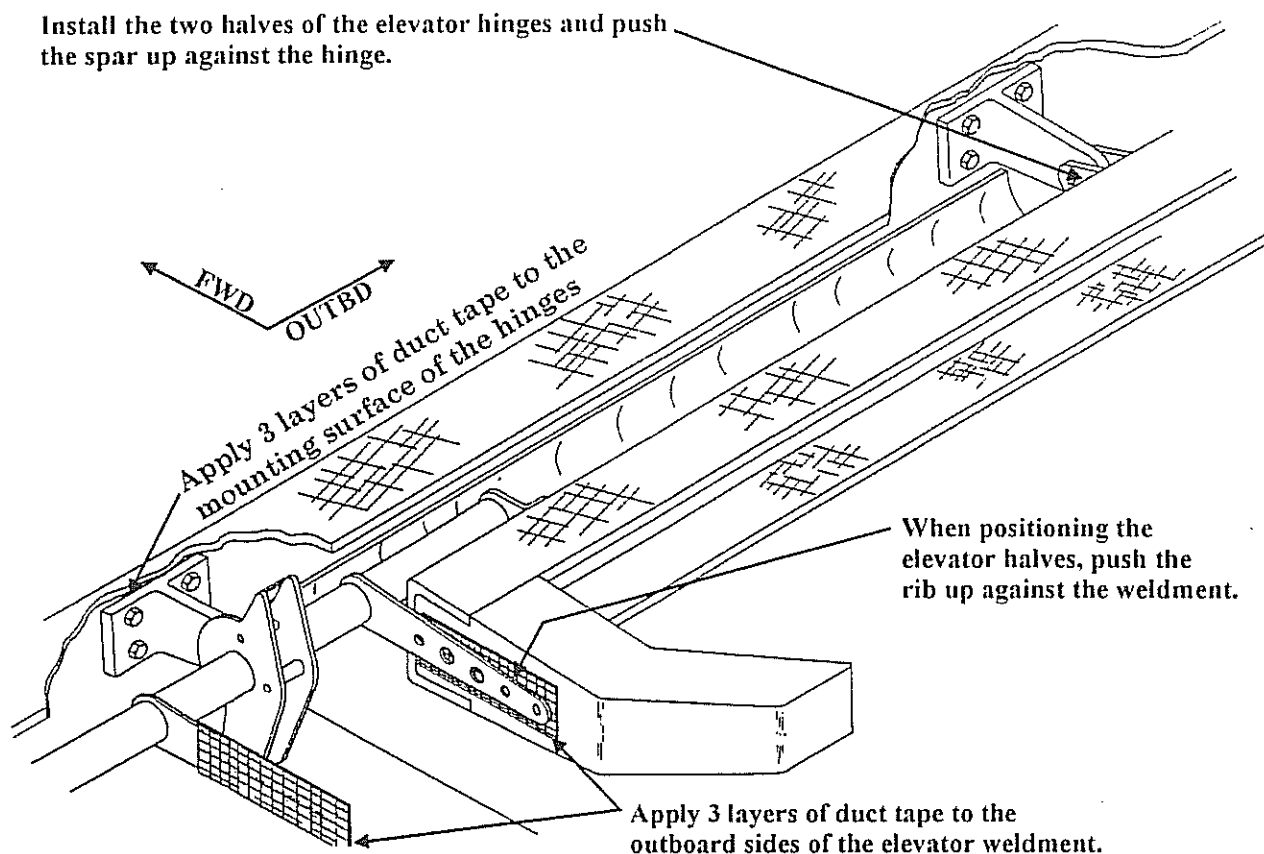

- C1. Install the center elevator hinge weldment. For this step, it is necessary to cut a slot in the center cradle to fit the weldment.
- C2. Position the elevators. In summary:
1. The inboard rib should be up against the weldment.
 2. Trim the outboard end of the H. Stab. main spar for elevator counterweight clearance.
 3. The spar should be forward up against the elevator hinges with 3 layers of duct tape under the horizontal at hinges. The duct tape simulates the three BID that will be applied after closeout.
 4. Trim the H. Stab. skin for elevator clearance along the horizontal trailing edge and in the counterweight area (Fig. 7:C:5 & 7:C:6). For now, just trim for clearance.
 5. The elevator should be weighted down into the cradle. Once aligned, temporarily secure the elevator hinges with superglue.
 6. Cut the holes for the hinges (Fig. 7:C:4).

Cutting Holes for Hinges in Elevator

Fig. 7:C:4

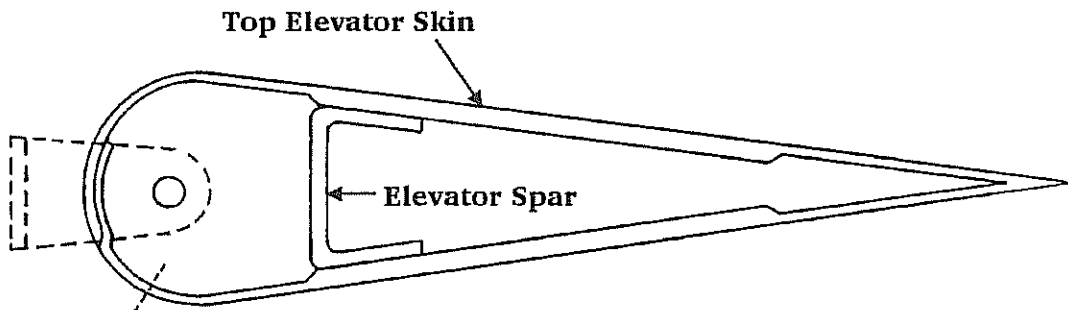

The opening is determined by elevator travel.
There should be 1/8" clearance between opening
and hinge at full travel

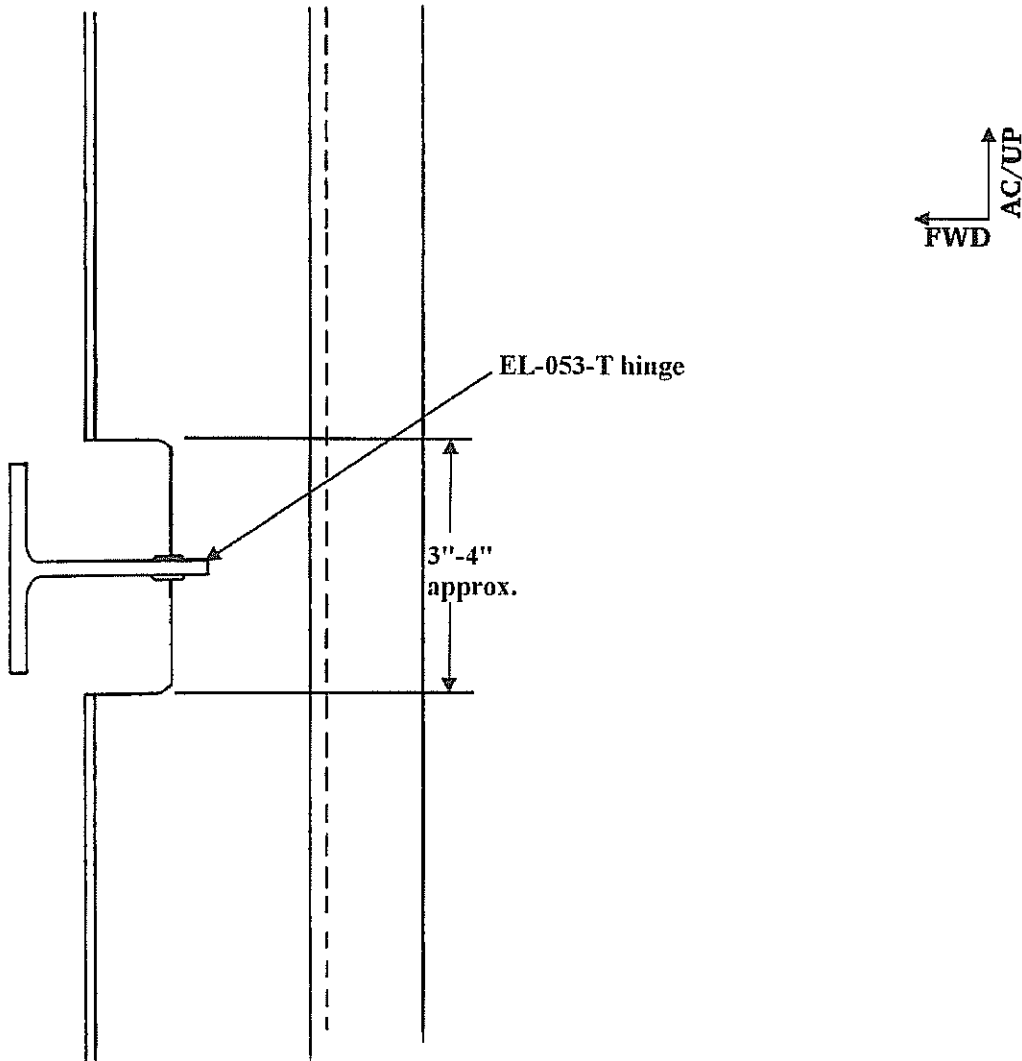

H. Stab./ Elevator Gap

Fig. 7:C:5.

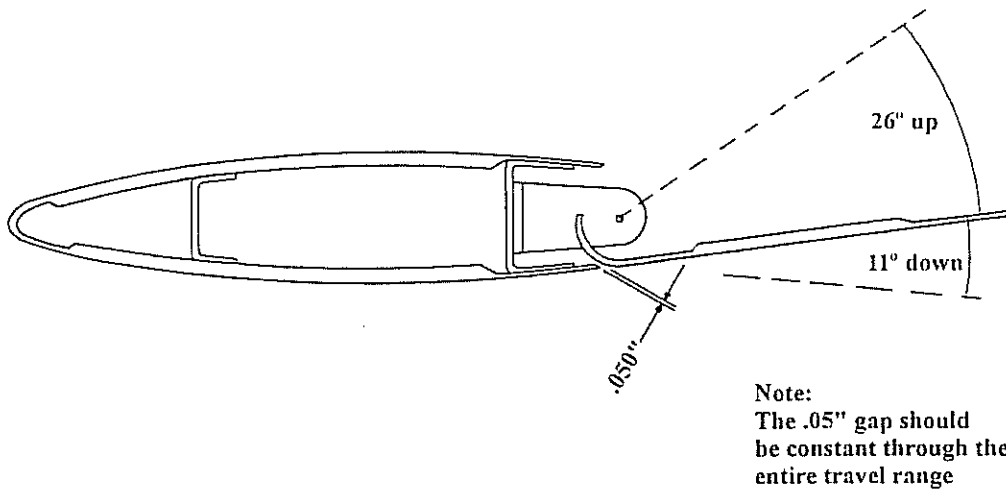

- C3. Recheck the H. Stab. elevator gap. Ideally there should be .05" between the H. Stab. and elevator as shown in Fig. 7:C:5. Most likely some body work will be required to get a constant gap through the entire travel range (this is normally done after the H. Stab. and elevators are closed). For now, simply trim the horizontal trailing edge so that it clears the front of the elevator and fine tune it later.

Trimming the H. Stab. T.E.

Fig. 7:C:5.a.

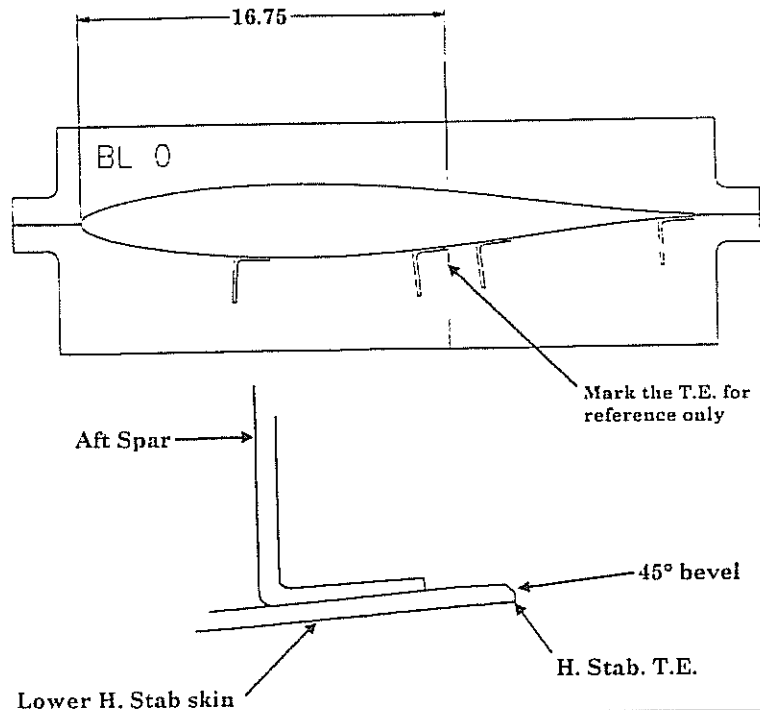

Drilling Holes for Elevator Hinges and Horizontal Stabilizer

Fig. 7.C:6.

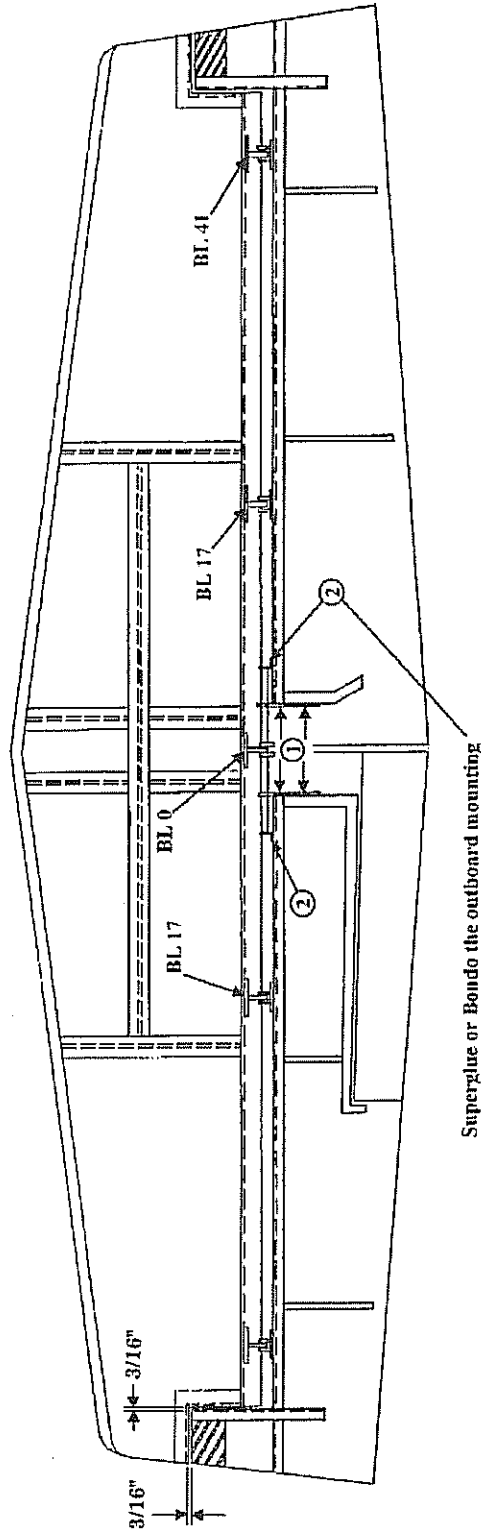

- C4. Remove the elevator. Drill the holes for the elevator hinges and the elevator weldment. The weldment should be centered heightwise on the inbd rib.

Installing the Elevator Hinges, Method #1

Fig. 7:C:7:a

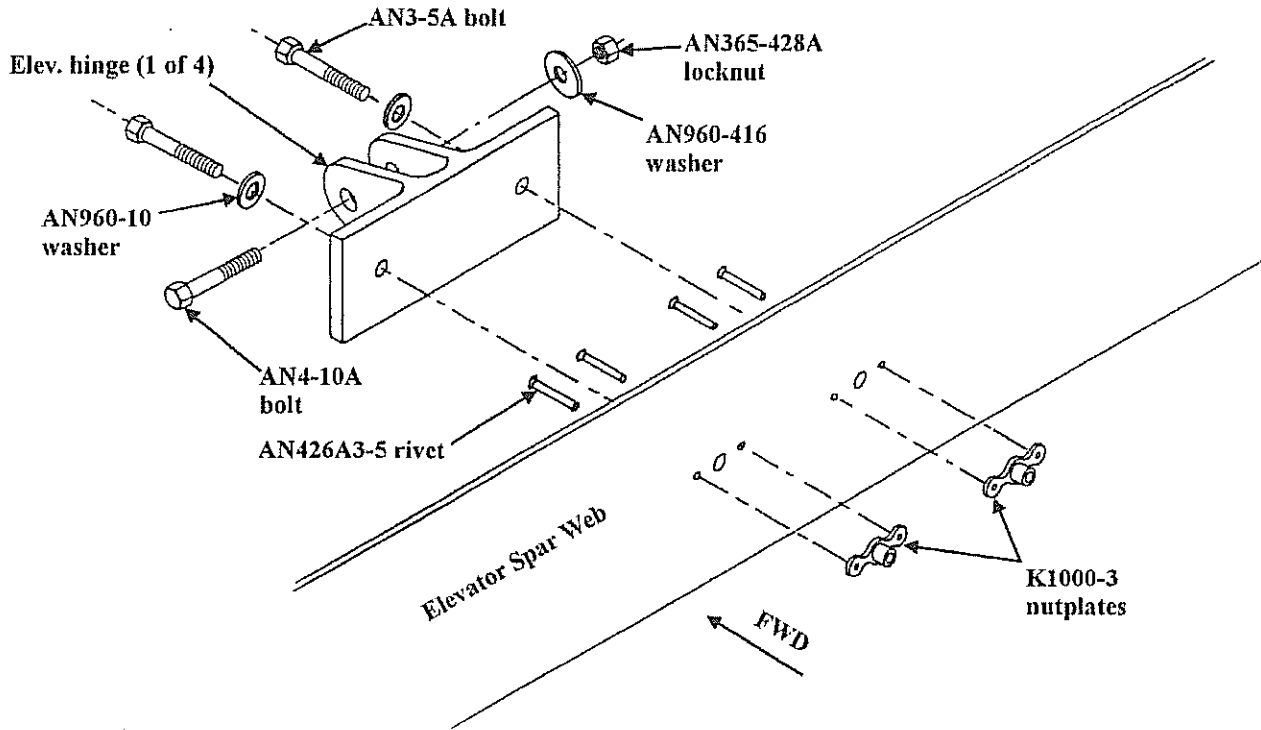

Installing the Elevator Hinges. Method #2.

Fig. 7:C:7.b.

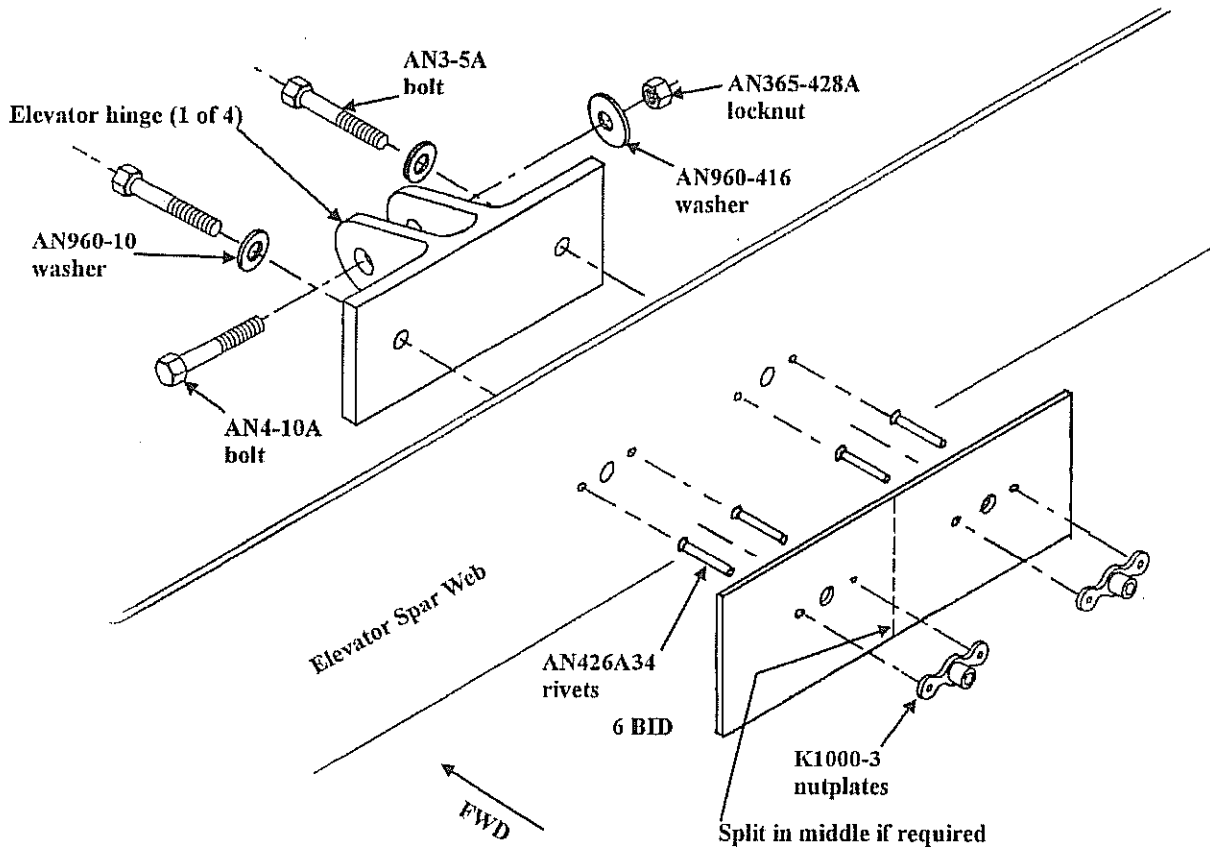

C5. Install the elevator hinges using either of the above methods.

Installing Nutplates for Elevator Weldment

Fig. 7:C:8.

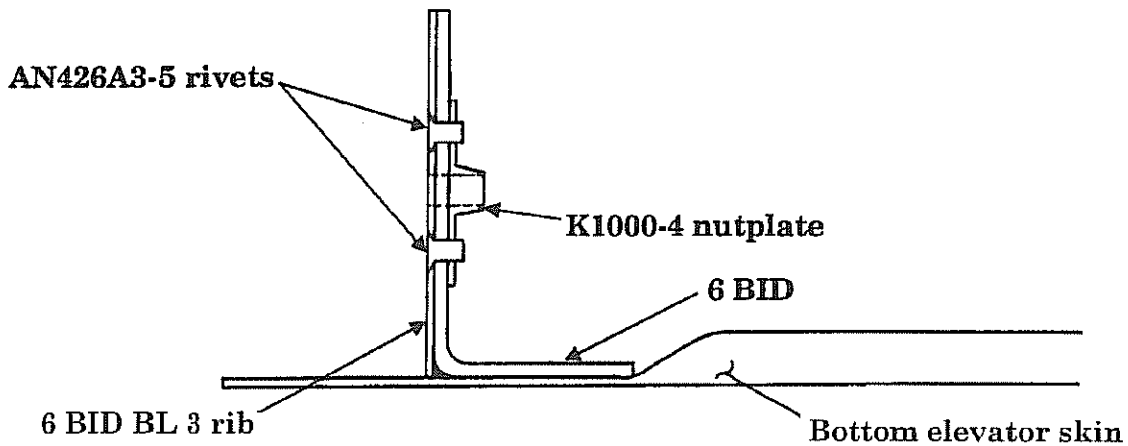
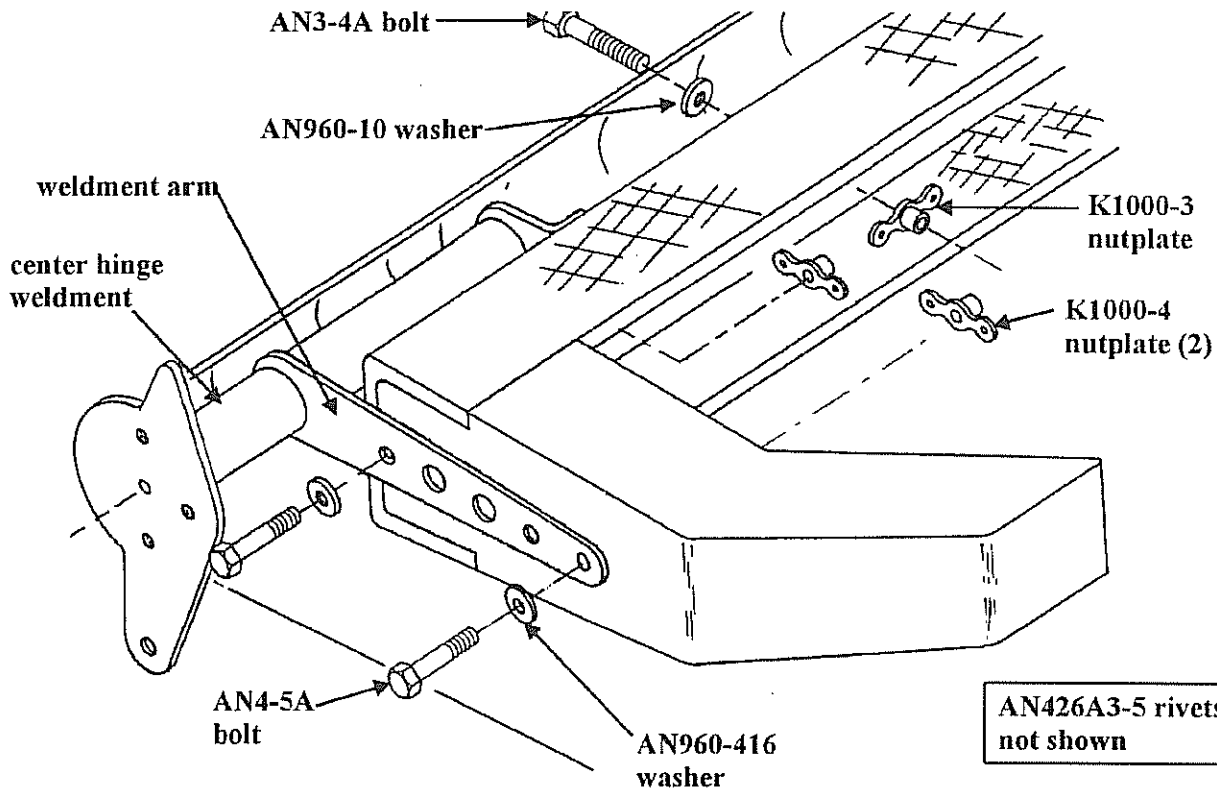

C6. Install the nutplates securing the elevator weldment.

D. TRIM MOTOR INSPECTION PANEL

The Lancair uses a MAC servo to adjust a standard trim tab on the elevator, thus providing pitch trim. There is a glass to glass area on the bottom elevator skin from which the inspection panel will be cut. For panels that are not glass to glass, core the area out and apply a glass 2 BID with an overlap of 1" onto the carbon. To find the proper angle of the inspection panel you will first mark the location of the trim tab.

- D1. Mark out the location of the trim tab on the bottom elevator skin from the dimensions given in Fig. 7:D:1.
- D2. Drill #40 reference holes at the corners of the trim tab. Don't cut the tab out yet, you will use the reference holes to cut the tab out after the elevator is closed.
- D3. Center your inspection panel at BL 9 at a right angle to the trim tab hinge line designated by the reference holes. The forward edge of the panel should be about 1" aft of the elevator spar. Mark the 4" x 4" outline of the inspection panel onto the inside of the bottom skin.
- D4. Do a segmented cut around the inspection panel. In other words, cut through the bottom skin on the panel outline, but leave 1/4" carbon at the corners uncut. The panel will stay in position while you lay up its mounting flange. A little bit of patience, a Dremel tool and their #426 fiberglass reinforced cut-off wheels (see your local hobby shop) will make a very nice, thin cut you can be proud of later.
- D5. Sand the area 1" around the panel with 40 grit to prepare it for the flange. Clean with MC.
- D6. Apply a 4" X 4" release to the inspection panel. Clear tape or packing tape will work well for a release here.

Trim Tab and Inspection Panel Locations

Fig. 7:D:1.

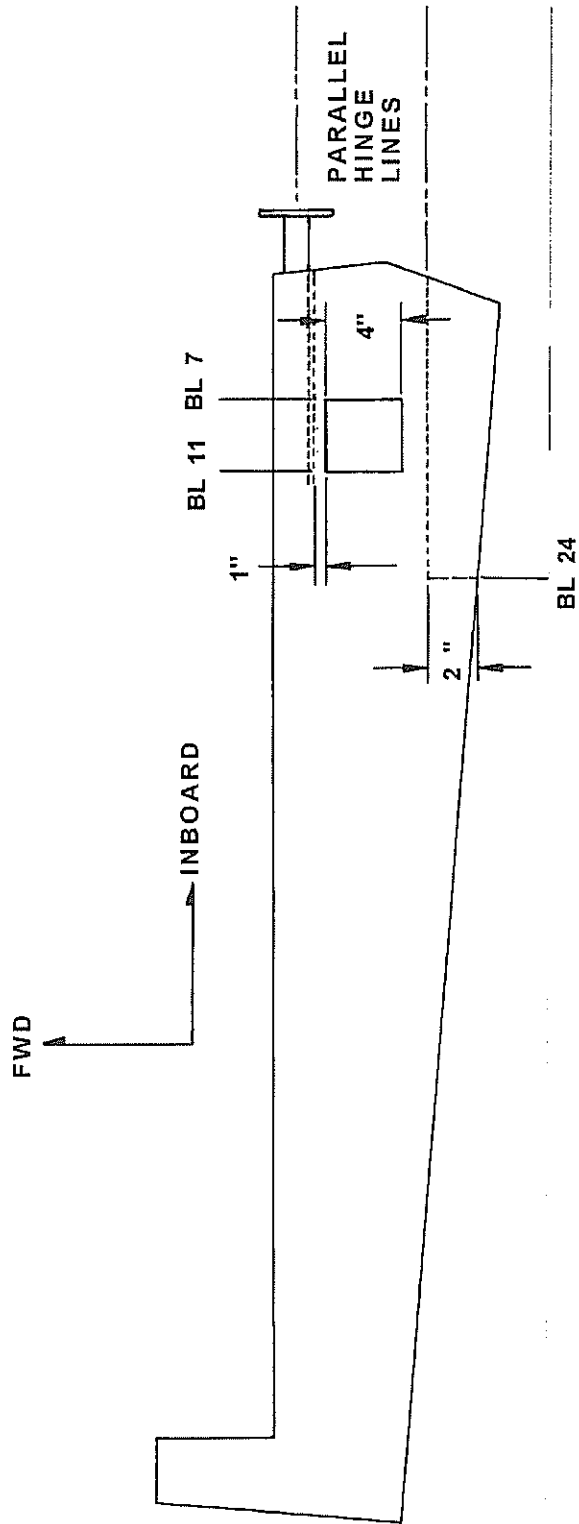

- D7. Apply a 4 BID, 1-1/2" wide flange around the inspection panel, centered on the segmented cut (see figure 7:D:2).

Inspection Panel Flange

Fig. 7:D:2.

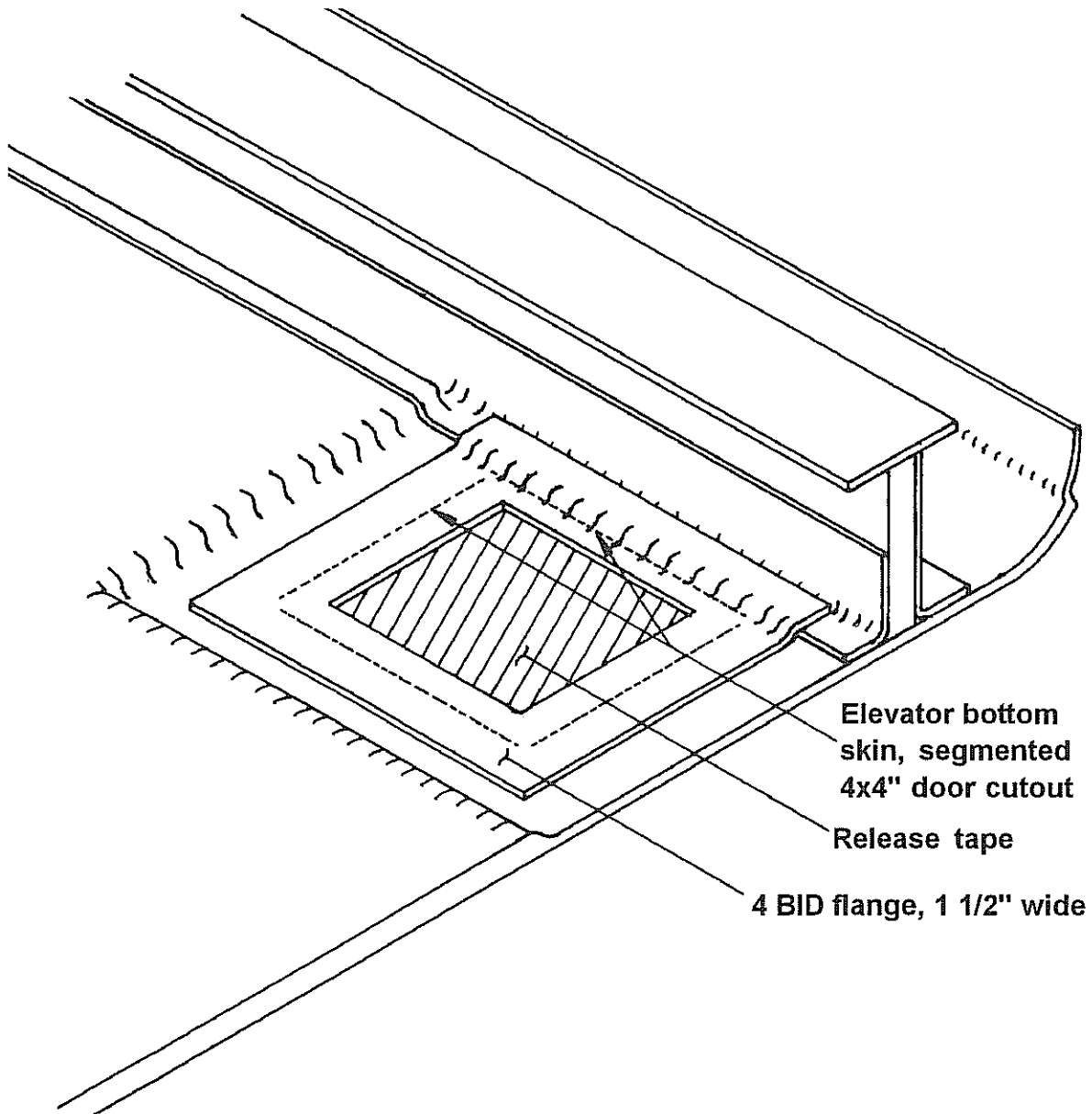

- D8. Temporarily close the elevators, using enough clecoes in strategic locations to keep the skins aligned.



- D9. Carefully finish the segmented cut of the servo inspection panel. Use a sharp mat knife or carefully cut with a Dremel rotary blade. The panel should pop off the flange.
- D10. Trim the inspection panel flange to 5/16".
- D11. Drill four #29 holes through the panel and the flange for the MS24693-S26 mounting screws. Countersink the panel to fit the screws.
- D12. Mount four K1000-06 nutplates to the flange using AN426A3-5 rivets.



7-30

Chapter 7	REV.	0/05-10-98
Horizontal Stab and Elevator		



E. COUNTERBALANCING THE ELEVATORS

Install the outboard rib

E1. Cut 2 ribs from 2 core 2 prepreg and bond in place at each end of the elevator (see figure 7:E:1). To do this you must core out the edge of the rib about 1/4" deep and fill it with micro/flox (see figure 7:F:1). Fit the rib against the inner counter balance closeout and up against the spar. Use 2" 2BID tapes to secure the front of the spar web to the rib.

E2. Pre-fit the top skin. This is done by applying 2 layers of duct tape to the skin and trimming the rib to clear it. Make sure the outboard rib fits well against the top skin with the duct tape in place. Again core out the edge of the rib and fill with microflox. Set the top skin in place and let cure. Remove the top skin and trim the squeeze out.

The elevators of the MKII are 100% mass balanced. Usually we prefer to close the elevators with plenty of weight and then drill the excess out after closing.

The elevators must move freely in order to balance them. You CAN NOT BALANCE an elevator that is not freely floating on the hinges.

IMPORTANT NOTICE: Balance the left and right elevator separately because they require different amounts of counterweight.

Before starting, the trim tab, servo, hinge, and all hardware must be temporarily installed or at least placed in their respective locations. The goal is to get as close as possible to the finished weight of the elevator.

E3. Drop the counterweights in place. Place the top skin in place. Note that what is still missing is the adhesive for closing, primer, and paint. Balance the elevator such that the L.E. of the counterweight arm hangs freely 1" to 1-1/2" below the 100% balanced position. This means that you will be adding weight as far forward as possible until the you have achieved the correct balance.

Installing the Counterweights

Fig. 7:E:1.

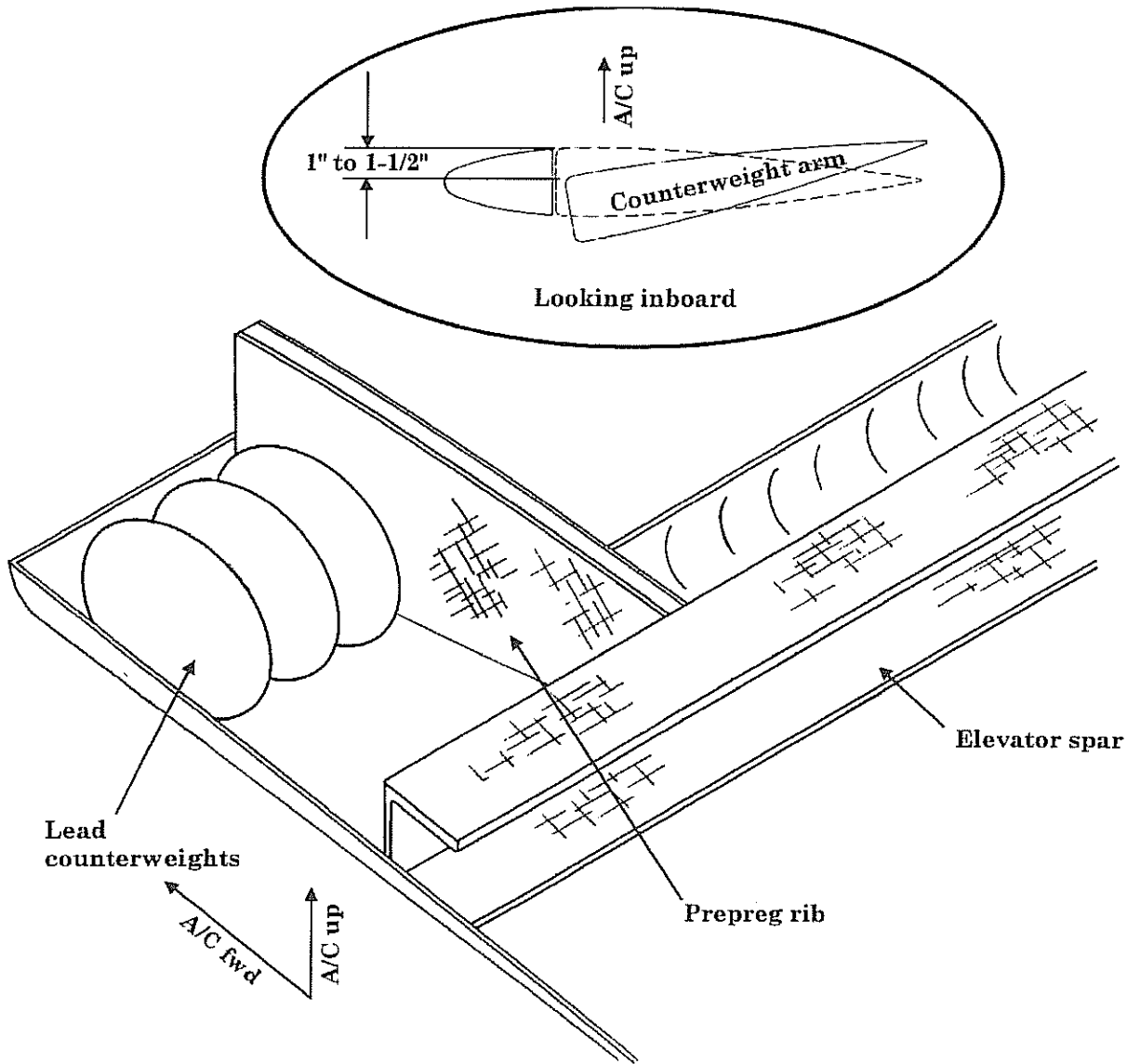

E4. When satisfied that you have sufficient counterweight, install the lead with epoxy/flox. Apply a 2 BID reinforcement to the aft side of the counterweight.

E5. When the elevators are closed and primed (ready to paint), check the balance again. Prior to paint, the counterweight should hang approx. 1" below the 100% balance position. If necessary, drill excess weight out. Fill the holes with micro and apply a 2 BID on top. Check the balancing again after paint and add or remove weight as necessary. Fill any drill holes with micro and touch up the areas.

F. CLOSING THE H. STAB AND ELEVATOR

F1. If holes are not already drilled, drill vent holes in ribs, webs, and the skin as shown in Fig. 7:F:1.

Horizontal Stabilizer and Elevator Vent Holes

Fig. 7:F:1.

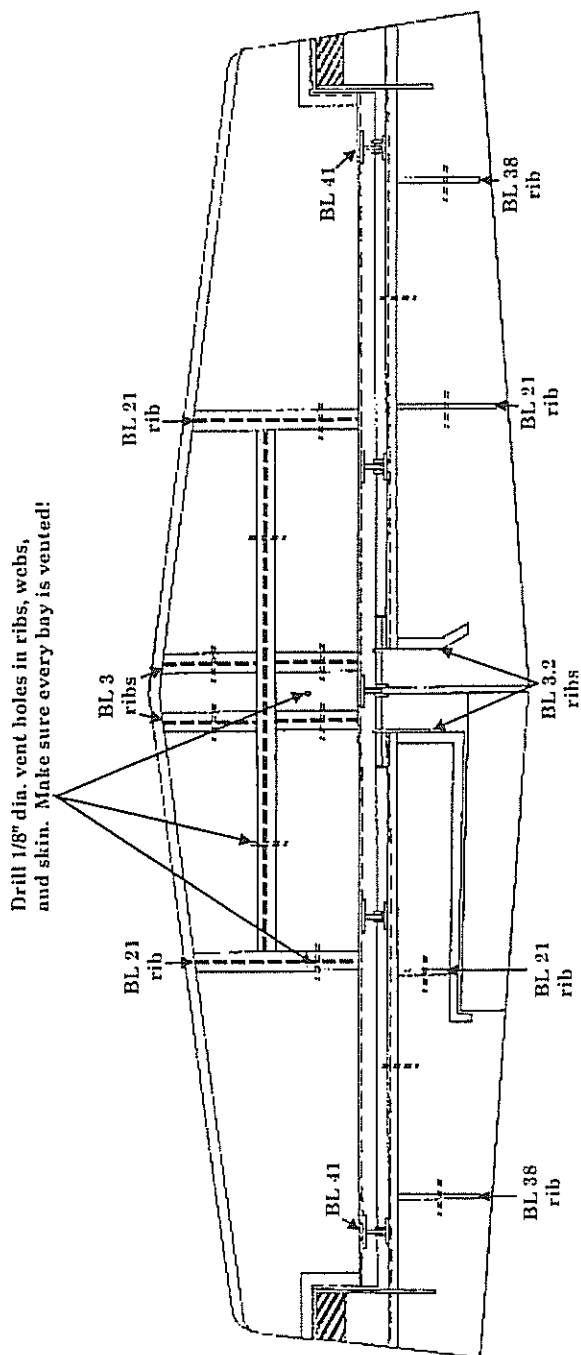



WARNING: ALL INTERNAL BAYS MUST BE VENTED. Failure to vent these bays could result in excessive internal pressure at high altitudes and cause structural damage that could result in component failure.

F2. Check the fit of the upper H. Stab. and elevator skins. A few things to look for:
 1. Place pieces of "play dough" every 6" on the spars, ribs, etc. Put the upper skins in place. Clamp the cradles in place and weight the skins down as if you were closing. If there are gaps between the top skin and the cradles, put a small wooden or prepreg shim in the area to hold the skin up in contact with the cradle. Look over the H. Stab. and elevators. There should be no visible bumps or irregularities, and it should fit the cradles well.

Remove the weights and cradles. The pieces of play dough should be .01 thick or flatter. If in excess of this, perform an epoxy flox release.

Epoxy/flox release:

The areas to be released must be sanded and cleaned with MC. The upper skin must be release-taped (duct tape, clear tape or equivalent) in these areas. First apply pure epoxy to the bonding areas with a brush and then the epoxy/flox mix. Lower the upper skin in place and clamp cradles in place. Weight down as if closing. Let cure.

When checking the fit, take note of the fit in each area. Practice the closing a couple of times before getting started. Get all the things you may need for closing- weights, clamps, straight edges, clecoes, etc. Decide what you will use to hold the leading edge joggles together during bonding (wood screws, clecoes, duct tape?).

F3. De-wax all the ribs, spars, and joggles using MC. Apply a generous amount with a clean rag or paper. Follow immediately with another clean, dry rag.

Preparing Surfaces for Bonding

Fig. 7:F:2.

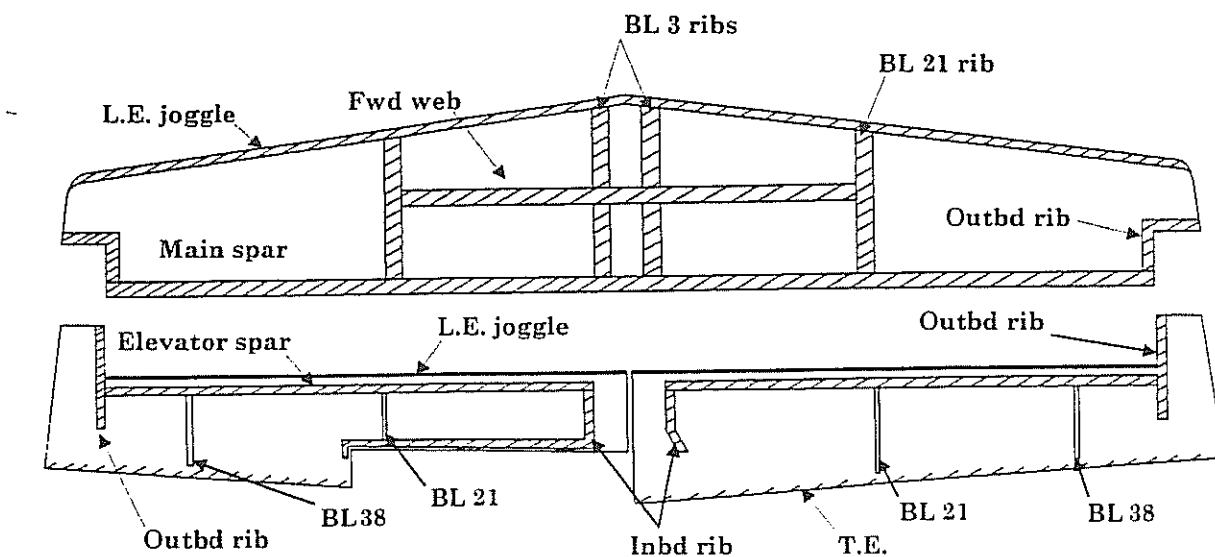

7-34

Chapter 7	REV.	A2/04-1-99
Horizontal Stab and Elevator		



Fitting the Upper Elevator Skin

Fig. 7:F:2:a

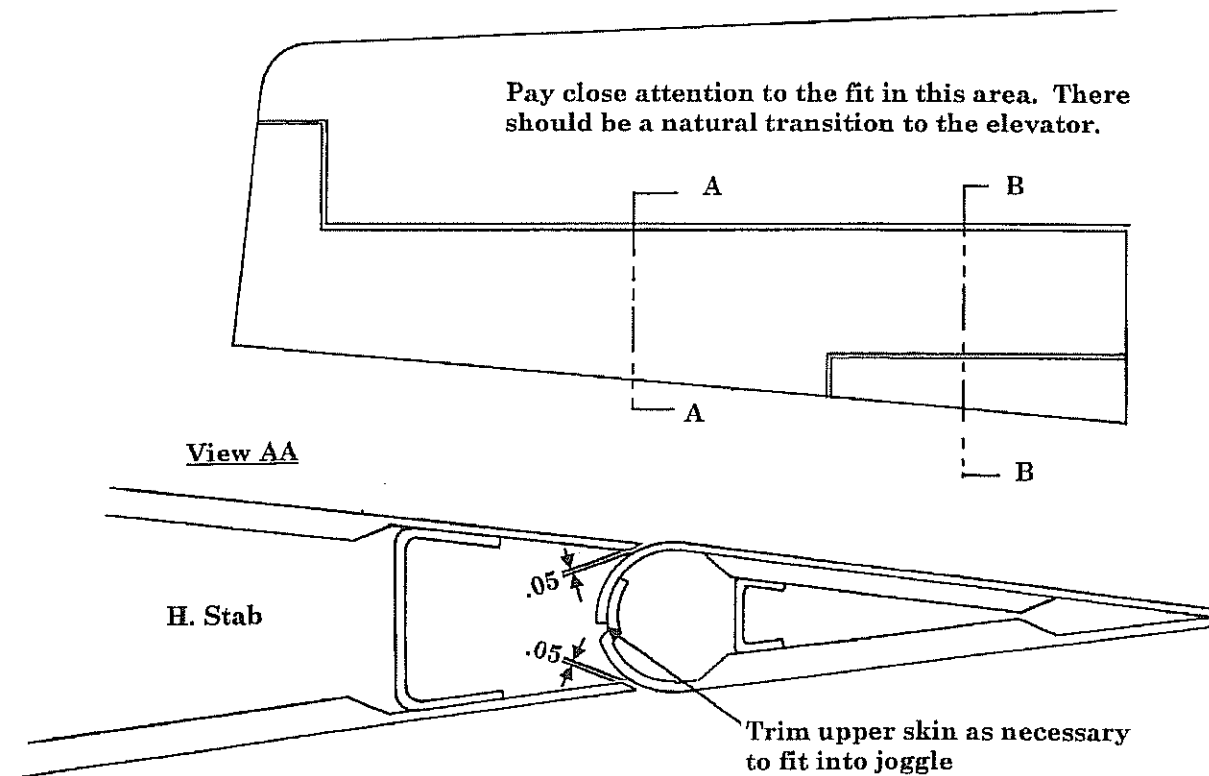

Note: The elevator is slightly thicker than the stabilizer

F4. Using 40 grit sandpaper, sand all bonding surfaces. Fig. 7:F:2 shows the bonding surfaces of lower H. Stab and lower elevator halves. Also sand the corresponding bonding surfaces of upper H. Stab. and elevator skins. Clean all bonding surfaces with MC.

Note: Before starting the closing process, the elevator and the H. Stab. must be positioned in the joggle. The weldment and hinges should be bolted in place (don't forget about the duct tape spacer on the weldment and the three layers of duct tape under the horizontal hinges).

Applying Adhesive to Bonding Surfaces of Elevator

Fig. 7:F:3.

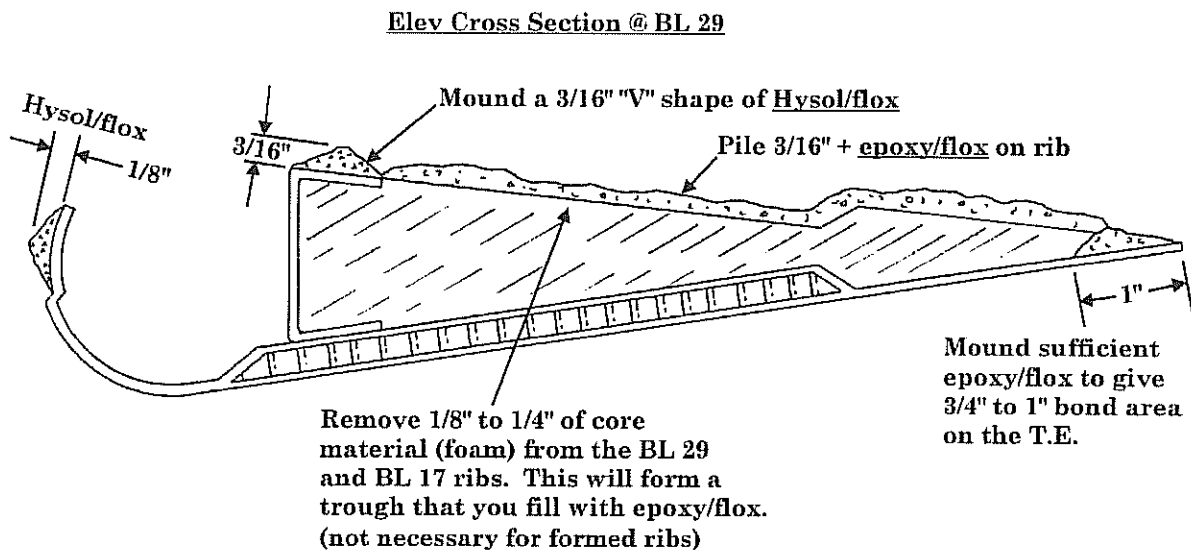

F5. Apply pure Hysol to the inboard and outboard ribs, the spars, the leading edge joggle and the parts of the counterweight arm that are to be bonded. Apply Hysol to the corresponding areas of the upper skin.

Apply Hysol or epoxy to the T.E. and the BL 29 and BL 17 ribs. Apply Hysol or epoxy to the corresponding areas of the upper skin.

Mix in flox with the Hysol and/or epoxy. Hysol: Mix in 1 tablespoon per 2 ounces of Hysol. Epoxy: Mix in enough flox to give it the consistency of peanut-butter (when you lift up a batch with the mixing stick, it shouldn't fall off!).

Apply the Hysol/flox and/or epoxy/flox mixes to their respective bonding areas of the lower skin and structure (see Fig. 7:F:3).

F6. When satisfied that all bonding surfaces have been sufficiently covered, carefully lay the upper skin in place and weight it for cure. Once clamped in place, you should see squeezeout along the T.E. and L.E., inboard rib, etc. Take a peek at whatever you can get to and assure yourself there is sufficient squeeze out.

NOTE: Once again you must use a straight edge to check that your skin is not bowed. You may have to shuffle your weights around to allow room for the straight edge check, but it's worth it. This is for all the marbles, so check and double check. Readjust weights if necessary.

Follow the same methods as you used on the elevators to close the H. Stab.

F7. When the Hysol has cured, sand the outboard joggles of each elevator. Clean with MC, and apply 2" wide 2 BID strips in the joggle.

LANCAIR MK-11FB

7-36

Chapter 7

REV.

0/05-10-98

Horizontal Stab and Elevator

F8. When the 2 BID has cured, sand it with 40 grit and smooth the outboard edges of the elevators with micro. Sand the micro to the same curvature as the horizontal stab.

F9. Remove the center hinge assembly and sand the inboard side of the BL 3.2 elevator ribs. Clean with MC and apply 2 BID, rolling onto the upper and lower elevator skins. Push some modeling clay, Silly Putty, etc. into the two mounting bolt holes on the inboard rib to prevent resin from clogging the threads. When the glass is in the green cure state you can trim around the bolt holes and remove the clay plugs. You can now remove the three layers of duct tape from the arms of the center hinges assembly that rested against the inboard elevator ribs. The surfaces that the weldment arms rest against should be absolutely flat (see Fig. 7:F:5).

Weldment Arm Mounting

Fig. 7:F:5.

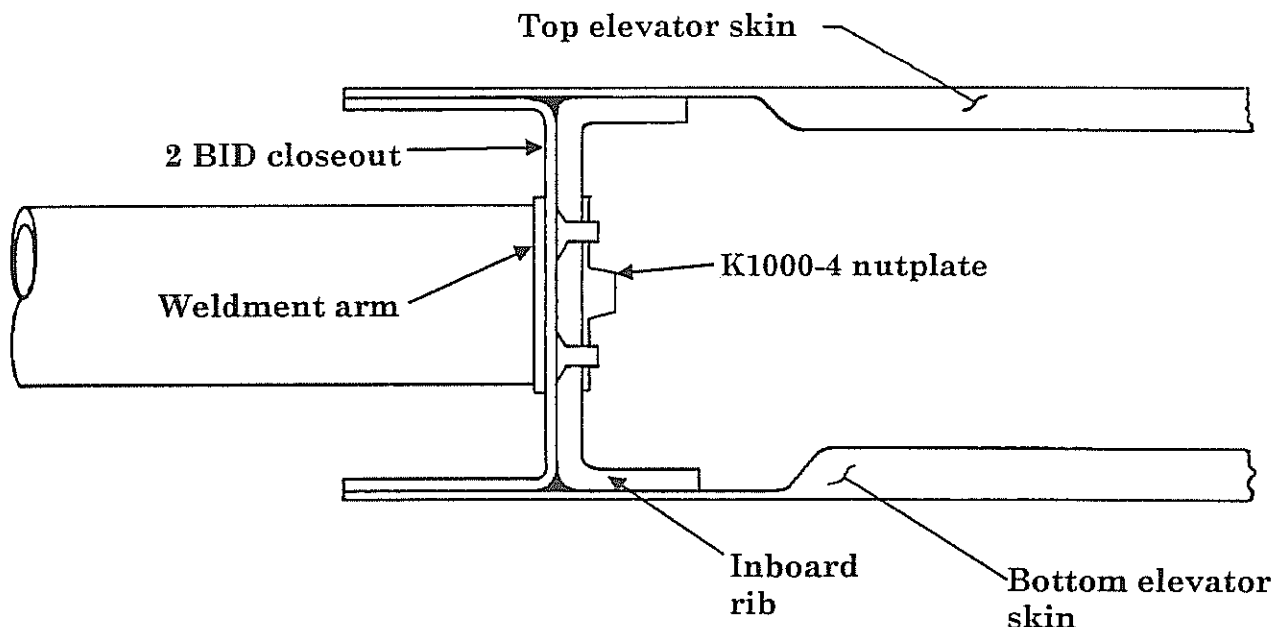

Remove the hinges from the H. Stab. and elevator. After cleaning and sanding, push modeling clay into the bolt holes like you did on the elevator and rib. Apply 3 BID to the rear face of the H. stab. spar making sure to roll it onto the upper and lower skins. Open the bolt holes, remove the clay plugs, and remove the duct tape from the hinges.

NOTE: To remove the bolts that secure the center hinge assembly to the elevator spars, you must grind an access hole in each elevator L.E. Make this hole just large enough on the bottom side so you can remove the bolts with a 3/8" socket.

F8. When the 2 BID has cured, sand it with 40 grit and smooth the outboard edges of the elevators with micro. Sand the micro to the same curvature as the horizontal stab.

F9. Remove the center hinge assembly and sand the inboard side of the BL 3.2 elevator ribs. Clean with MC and apply 2 BID, rolling onto the upper and lower elevator skins. Push some modeling clay, Silly Putty, etc. into the two mounting bolt holes on the inboard rib to prevent resin from clogging the threads. When the glass is in the green cure state you can trim around the bolt holes and remove the clay plugs. You can now remove the three layers of duct tape from the arms of the center hinges assembly that rested against the inboard elevator ribs. The surfaces that the weldment arms rest against should be absolutely flat (see Fig. 7:F:5).

Weldment Arm Mounting

Fig. 7:F:5.

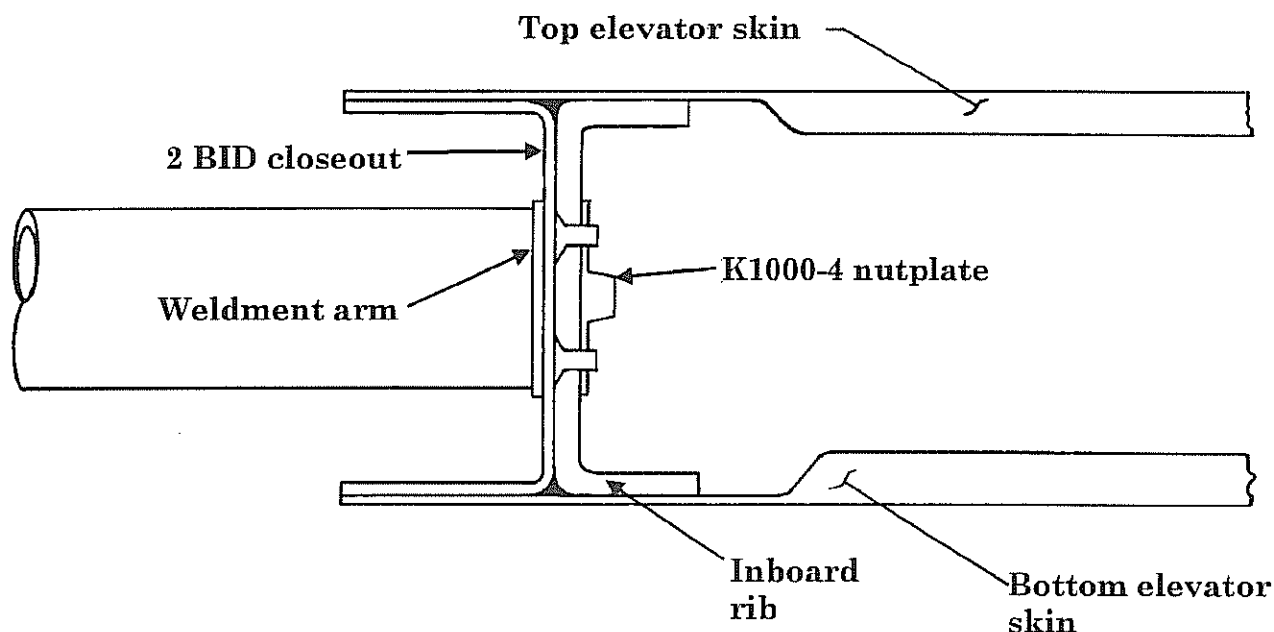

Remove the hinges from the H. Stab. and elevator. After cleaning and sanding, push modeling clay into the bolt holes like you did on the elevator and rib. Apply 1 BID to the forward face of the elevator spar and 3 BID to the rear face of the H. stab. spar making sure to roll it onto the upper and lower skins. Open the bolt holes, remove the clay plugs, and remove the duct tape from the hinges.

NOTE: To remove the bolts that secure the center hinge assembly to the elevator spars, you must grind an access hole in each elevator L.E. Make this hole just large enough on the bottom side so you can remove the bolts with a 3/8" socket.



F10. Close out the edges of the horizontal stab in the counterweight area with 2 BID, 2 ply per side fiberglass prepreg. Keep about a 0.050" gap between horizontal stab and counterweight, and be sure that gap doesn't close or open up when the elevator is moved up and down. The H. Stab. BL 45 rib is probably very close to being flush in the counterweight area. If it isn't you can either flush out this face with micro or bond in a piece of Clark foam with 1 BID over it. Or you can use a piece of 1/4" prepreg with inside skin and core trimmed to slip into cavity.

Flushing out face

Fig. 7:F:6

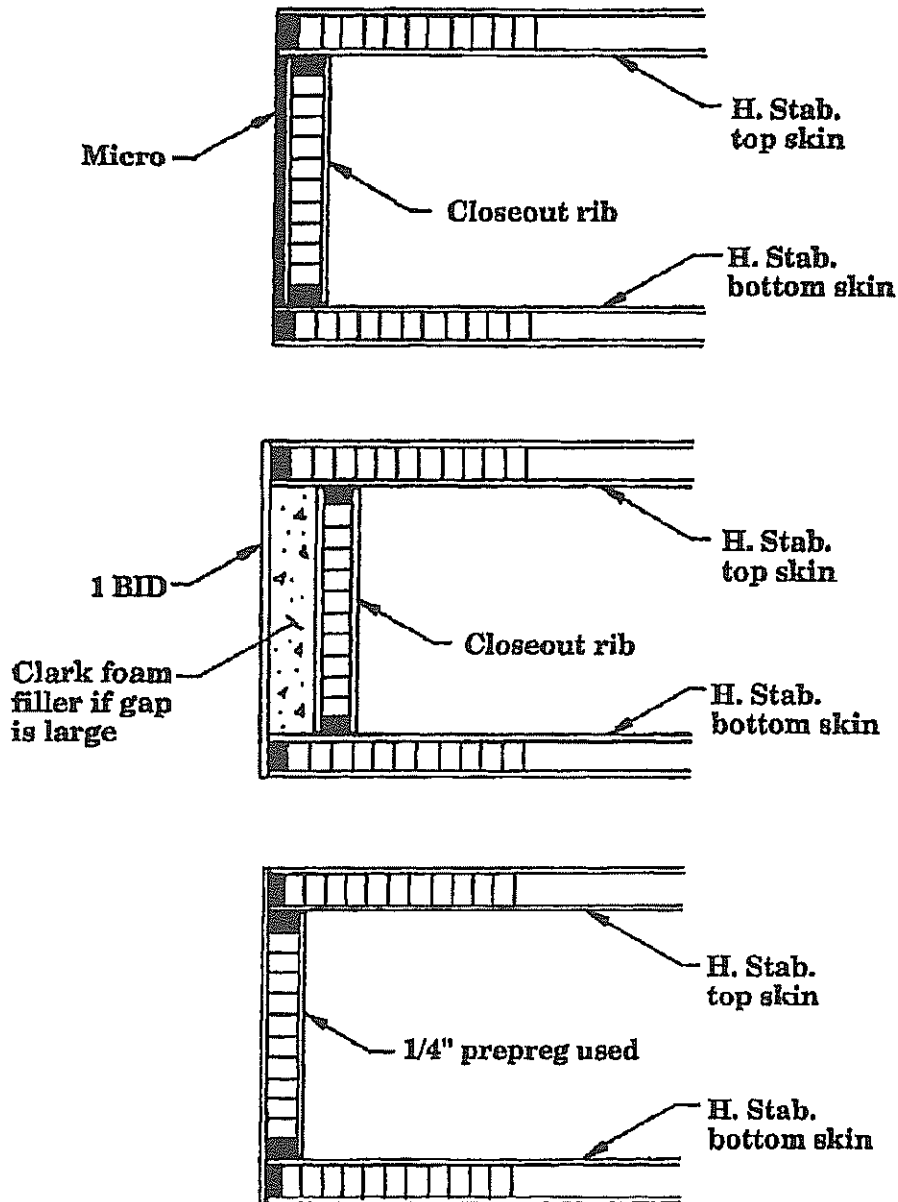

Closing of Horizontal Stabilizer

Fig. 7:F:7

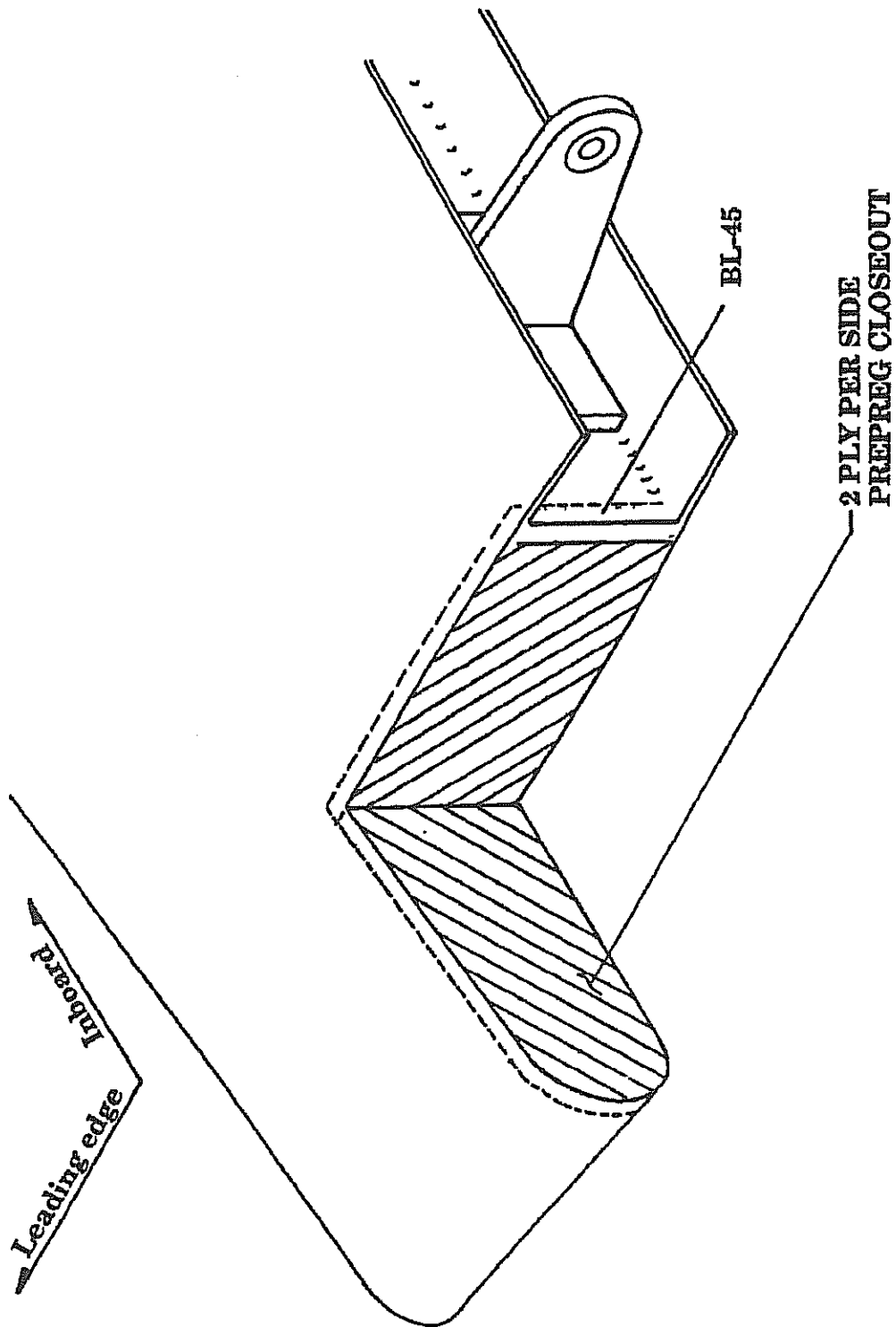

F11. Use micro to smooth out the inboard and forward faces of the counterweight arm, again making sure the gap doesn't close up when the elevator is moved. Sand a 3/8" radius along the forward top and bottom edges of the counterweight arm to lessen the drag when the elevator is trimmed out of neutral.

NOTE: If you are concerned about icing around the control surface gaps you can open up the gaps to a 1/4" and round out the counterweight arms more. This will give you a little more time to get out of the icing conditions. As a reminder, this A/C is not approved for flight in known icing conditions.

Opening Up the Control Surface Gaps

Fig. 7:F:8



Open gaps to 1/4" minimum

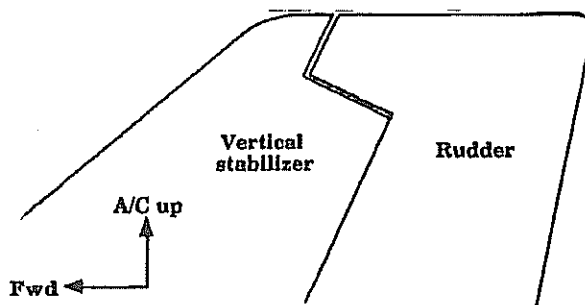

F12. To remove and install the hinge bolts, you will have to notch the bottom leading edge of the elevator. Remove just enough carbon so you can get to the bolts with needle-nose pliers. As you will soon discover, installing the elevator is not all fun and games, especially when it's mounted on the fuselage and you have to hold the elevator while aligning and bolting the hinges, upside down. A wonderful tool to simplify this procedure is made from a long AN3 bolt with the threads cut off. See Fig. 7:F:6. Use the tool to align the elevator hinge half with the horizontal stab hinge half that has the 1/4" bearing pressed into it. Insert the proper AN4 bolt into the other side of the elevator hinge half, wiggle it slightly, and push the alignment tool out with the bolt. Easy!

Hinge Alignment Tool

Fig. 7:F:9.

HEAT THE BOLT
WITH A PROPANE
TORCH TO BEND.

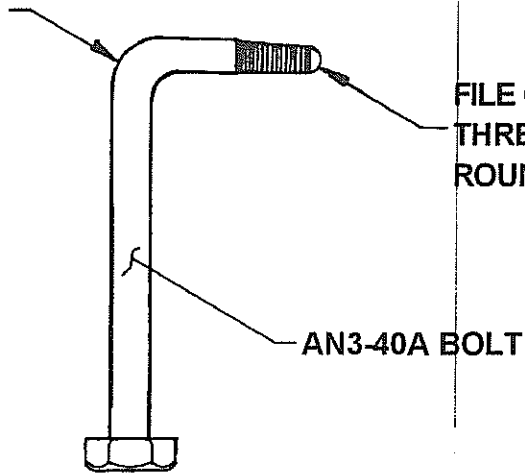

FILE OR GRIND THE
THREADS SMOOTH.
ROUND THE END.

AN3-40A BOLT



G. MAC SERVO STANDARD TRIM TAB INSTALLATION

- G1. Cut a 3" X 3-1/2" piece of 1/8" thick phenolic to be used as a servo mount.
- G2. Center the servo on the phenolic. Use the servo as a guide to drill two #29 mounting holes in the phenolic for the two rear screws.
- G3. Countersink the holes on the underside of the phenolic to accept MS24693-S28 screws. Trim the screw heads flat on one side so that when they are potted into the phenolic they won't turn.

Trimming Screw Heads

Fig. 7:G:1

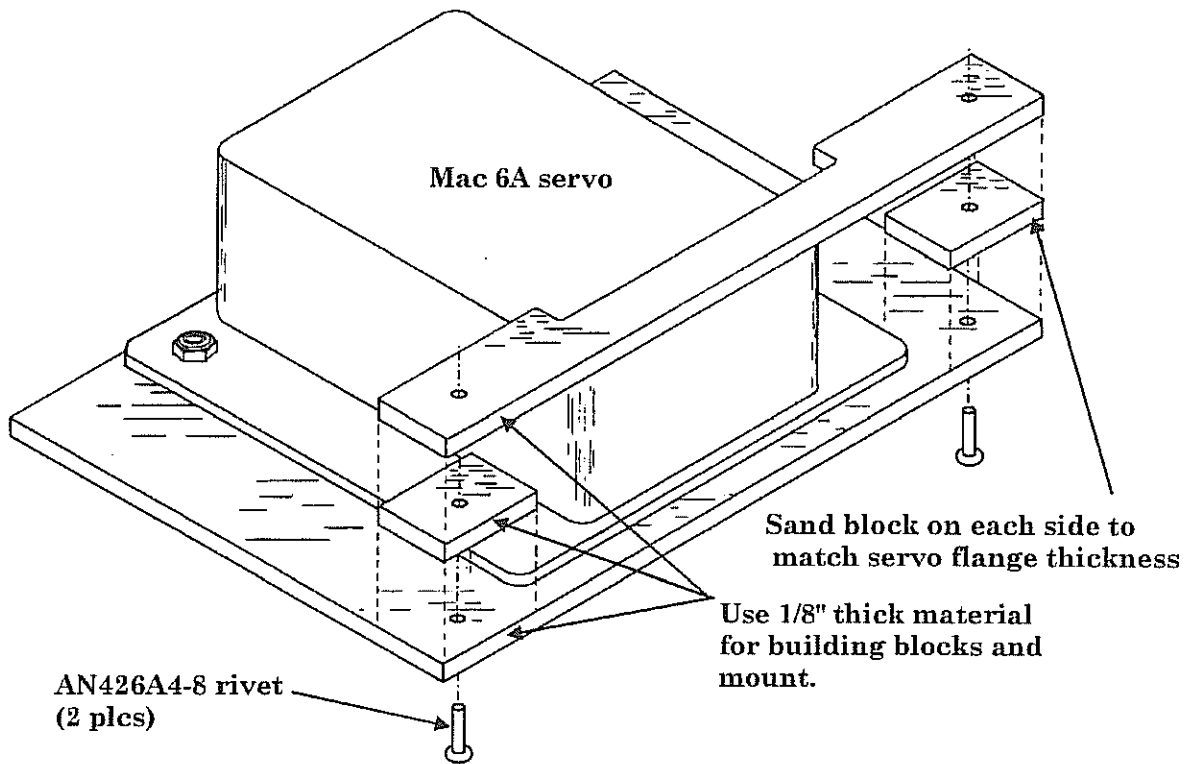

- G4. Using epoxy/flox or Hysol, pot the screws into the phenolic. Use the trim servo to align the screws (now referred to as studs) while the epoxy/flox cures. Wipe off excess epoxy/flox before setting the servo into position to avoid bonding the servo permanently and let cure. Make the blocks and the flange out of 1/8" phenolic. Sand both the phenolic parts and servo mount. Release tape the servo and bond the blocks in place with Hysol. Drill an 1/8" hole through each block set and install AN426A4-8 rivets. Be sure to insert the rivet up through the bottom of the servo mount.



- G5. Sand the flat face of the phenolic and the top skin bonding area with 40 grit and clean with MC.
- G6. Using Hysol, bond the phenolic servo mount to the inside of the top elevator skin. Position the mount so that the servo is aligned with the inspection panel and the trim tab hinge line and is as far forward as possible.
- G7. Drill holes in the bottom elevator skin as guides and saw out the trim tab from the elevator. A hand held hack saw blade works well for cutting through top and bottom skin at one time. Notice that your hingeline cut in the top elevator skin should be parallel to the hinge line of the elevator.



Cutting Out Trim Tab

Fig. 7:G:2.

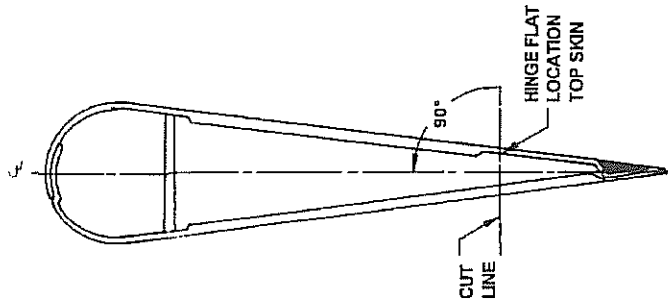

RIB
AT INBD
LOCATION

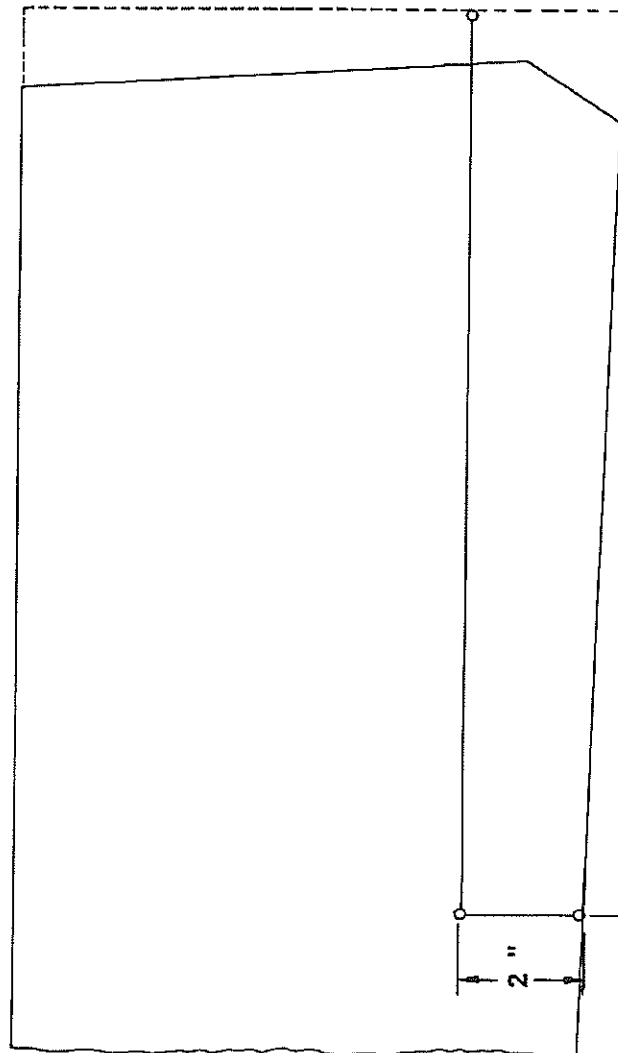

TRIM INBD
RIB TO FIT

BL 24

- G8. Cut a 20" piece of MS2001-5 hinge.
- G9. Sand the edges you have just cut straight. Fit the hinge to the trim tab and the elevator so the T.E. of the tab is in line with the T.E. of the elevator. You will have to sand the L.E. of the trim tab and the elevator (only in the trim tab area!) to allow the tab to achieve full "up" travel. Don't get confused here, "up" trim tab movement will force the elevator down, thus trimming the aircraft nose down (see fig. 7:F:8).

Hinging the Trim Tab

Figure 7:G:3.

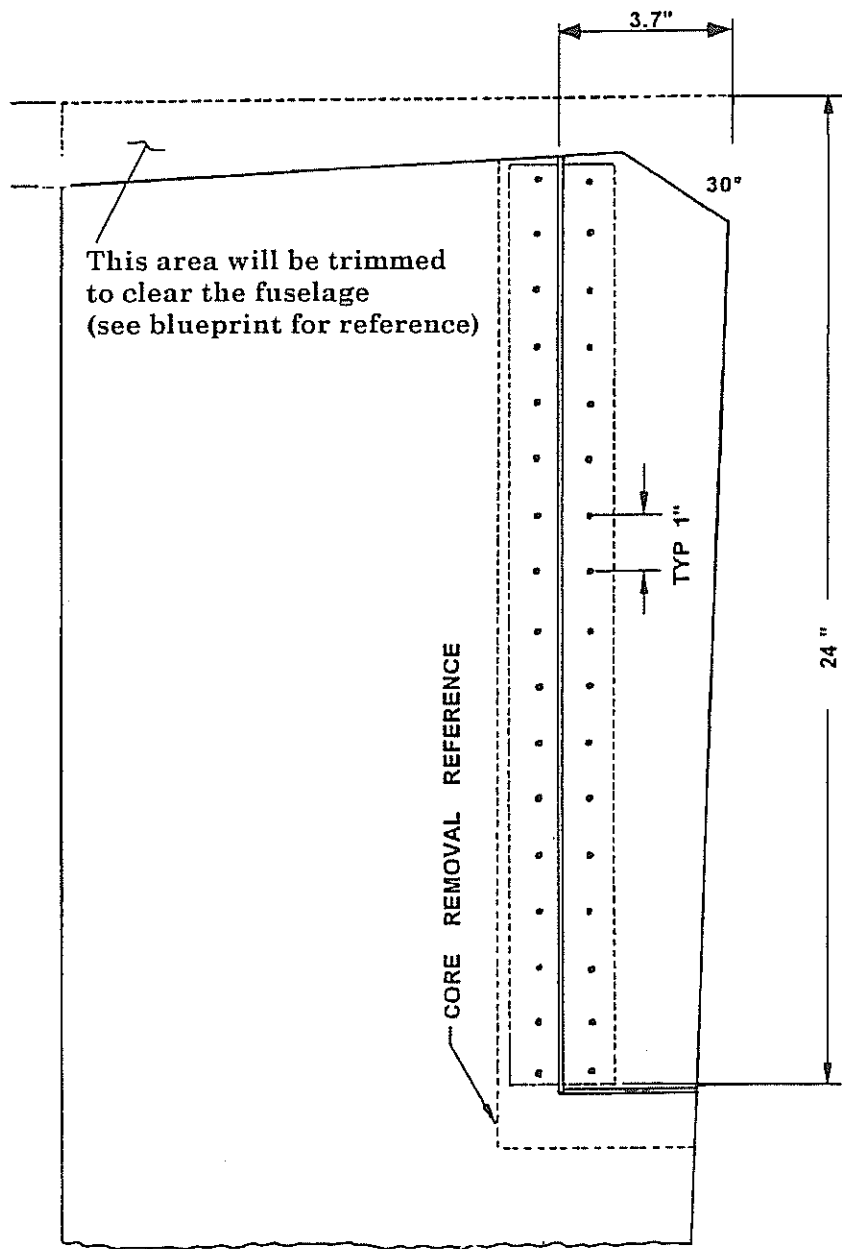



- G10. You can test your hinge placement by temporarily bonding the hinge in place with instant glue. You can then swing the tab up, not down just yet, and see how much top skin you should bevel or remove. The BL 3.2 elevator rib must be trimmed away from the hinge area. Cut this rib back just far enough so the hinge can be mounted on a flat area.

- G11. By now you have noticed that the forward edges of the trim tab tend to bow in. The rear edges of the elevator in the tab area will tend to do the same thing. This is because the skins are unsupported. Cut thin spars out of 1/4" thick, 2 PPS prepreg for the trim tab and the elevator to support the skins in these areas. Secure the spars in position with flox/micro and wrap 1 BID around the spar and onto the hinge areas and skins as shown in Figure 7:G:4:a. This BID is not shown in later figures for clarity purposes (see Fig 7:G:4:b).

Adding 1 BID
Fig. 7:G:4.a.

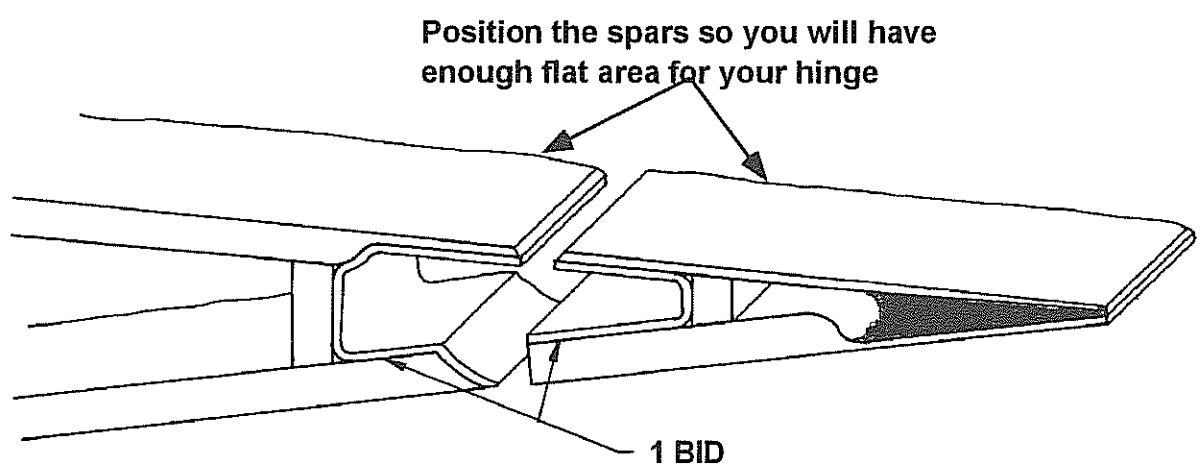

Support Spars

Fig. 7:G:4:b.

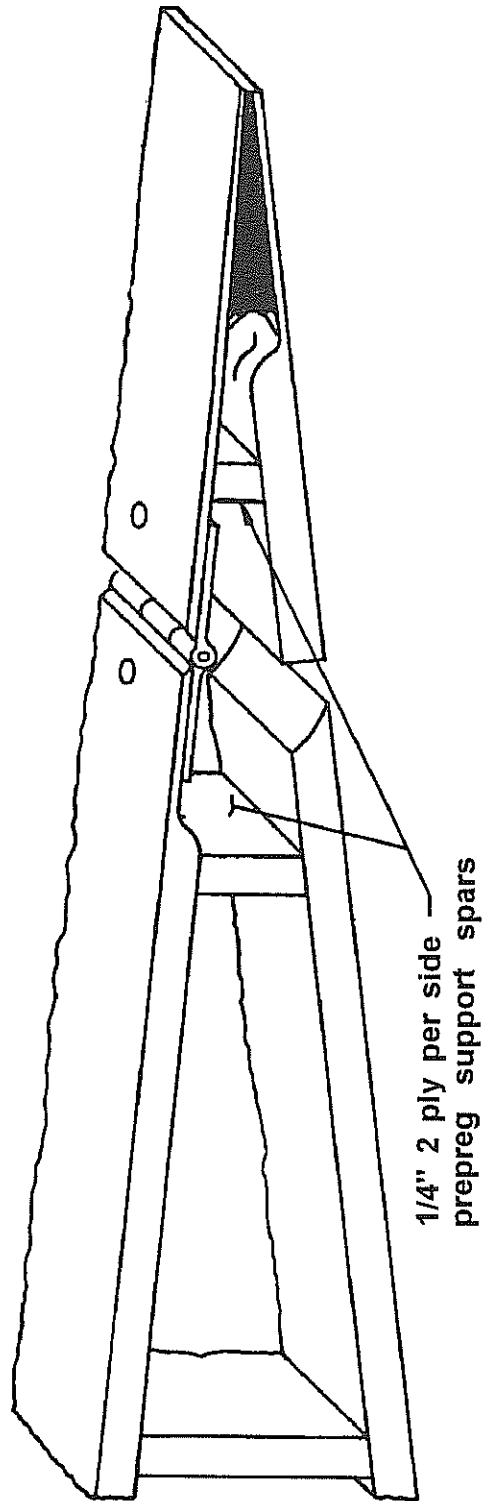



- G12. When satisfied with the hinge location, drill #40 holes spaced 1" apart and countersink for AN426A3-5 rivets on the trim tab. Drill six #20 holes and countersink for #8 screws on the elevator side. Mount nutplates on the hinge and mount the tab on the elevator. Secure the hinge halves to the trim tab with the rivets. Don't drill any holes in the hinge arm area yet (pre-align servo and hinge arm location).
- G13. Trim enough of the bottom trim tab skin and the elevator skin so the tab can be moved to the full down position.
- G14. Align the hinge arm with the servo actuator arm. Locate the hinge arm on the trim tab hinge as shown in Fig. 7:G:5:b. notice that you must slot the edge on the bottom skin for the hinge arm clearance.

Trim Tab Hinge Arm

Figure 7:G:5:a.

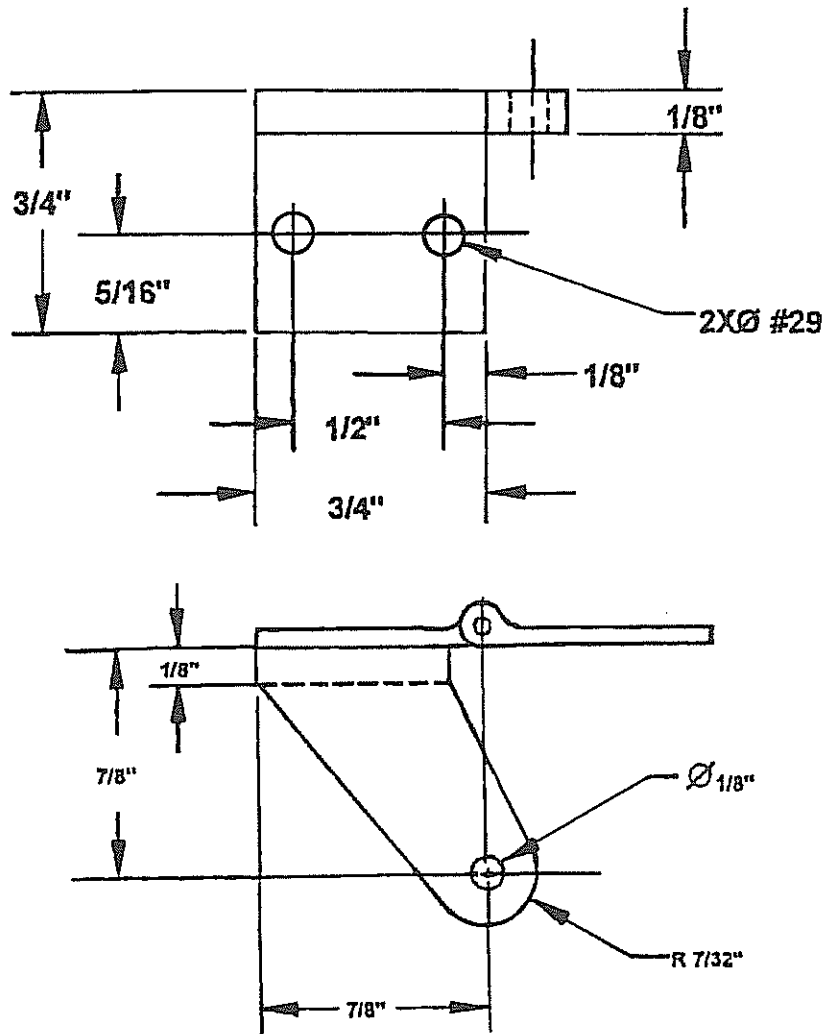

Trim Tab Hinge Arm

Fig 7:G:5:b.

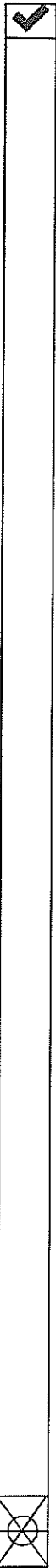
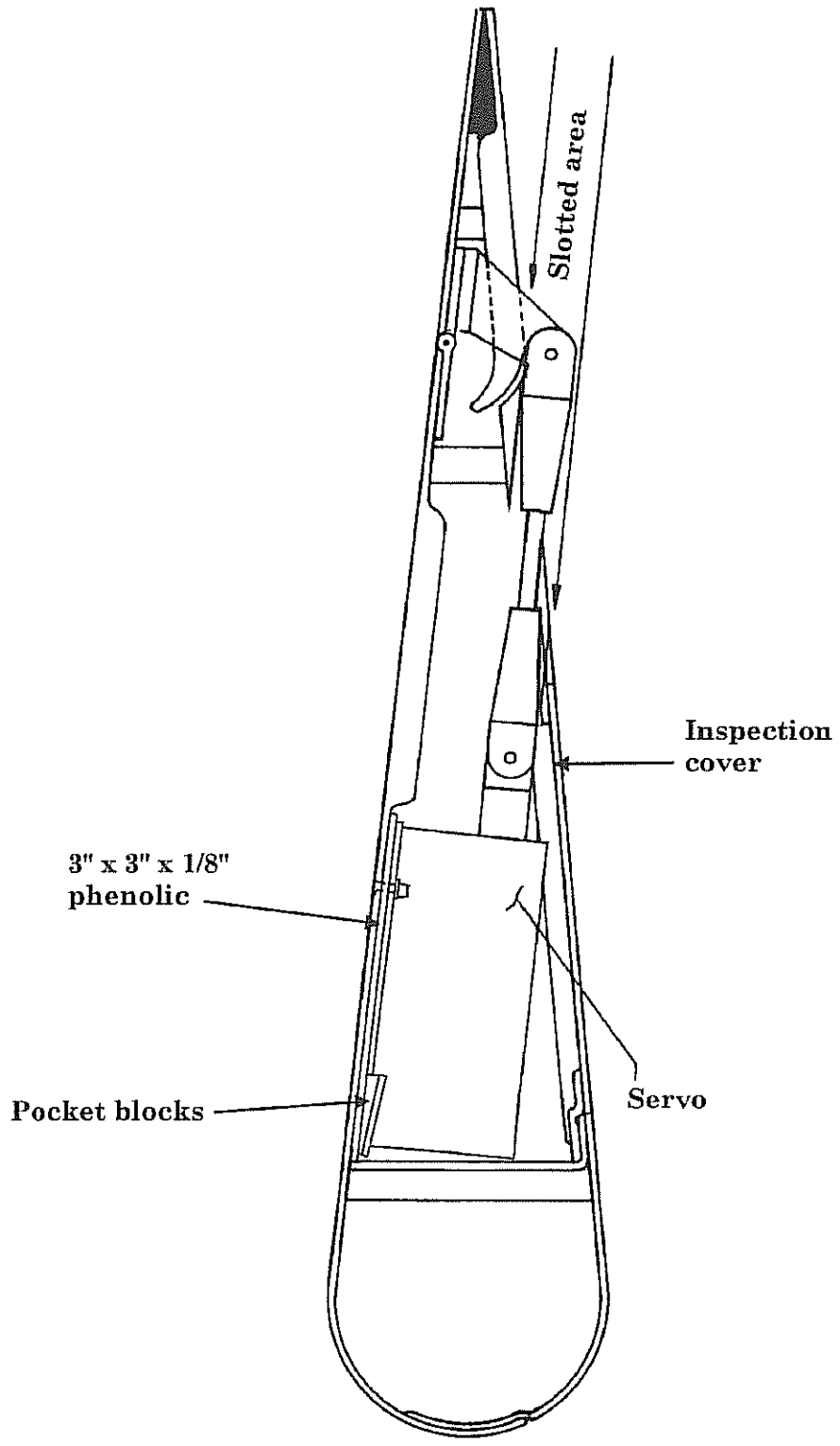



- G15. Mount the hinge arm to the trim tab hinge using MS24693-S26 screws. Use M21042-06 lock nuts.
 - G16. Slot the bottom elevator skin for the trim tab actuator rod. Using a Dremel tool, slowly expand the slot so the rod and clevis will clear at both extremes of travel. Don't worry about notching the skin support spar, that is OK.
 - G17. You can test the servo and check for proper tab deflection by using a nine volt battery to run the servo. To reverse the direction of servo travel, simply reverse the white power leads on the battery. The servo will shut itself off at extremes of travel. The tab should extend approximately 25°-30° up and down.
- Note: If an anti-servo tab is to be used, additional travel ranges will be required, up to approximately 45° in both directions.
- G18. Drill a small hole through the elevator spar to route the wires for the servo. Keep the servo wires close to the center of the hinge to avoid excessive bending and wear on the wires.
 - G19. Now you have to bond in and form a foam block to fill the ugly gap on the underside of the trim tab.
 - G20. Using micro, bond a 1/2" x 20" x 1-1/4" piece of Clark foam to the L.E. surface of the bottom trim tab skin leaving a gap for the hinge arm.
 - G21. Shape the foam so when the tab is moved to its extreme travel, the gap stays constant. This will be a contour lined that scribes a radius off the hinge pin axis (see fig. 7:G:6:a and b).

Shape of the Foam

Fig. 7:G:6:a

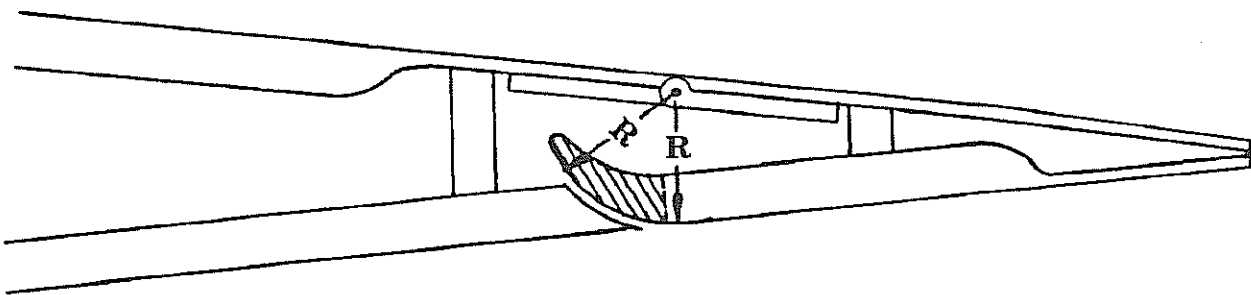

Trim Tab L.E. Shape

Fig. 7:G:6:b

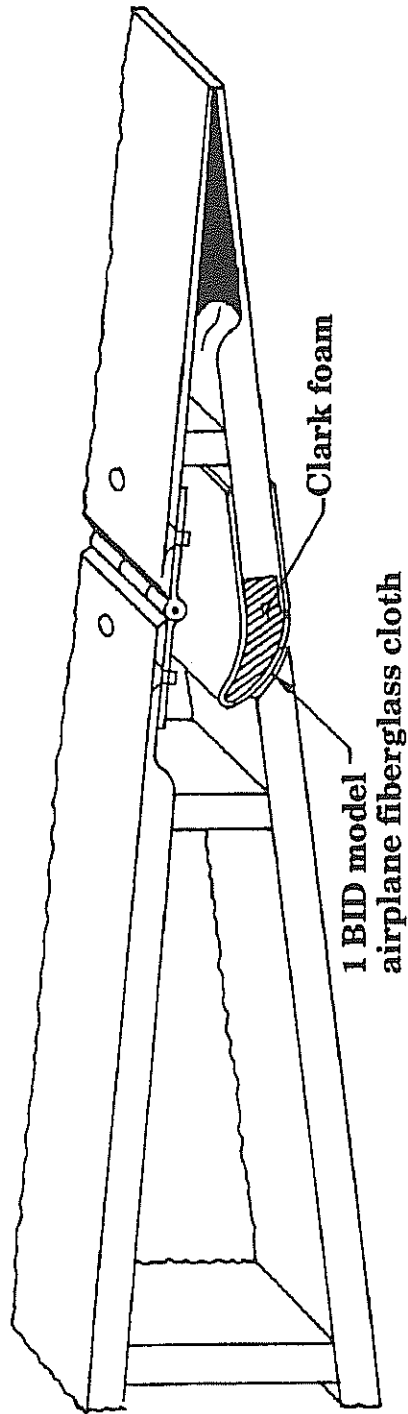



- G22. When satisfied with the trim tab elevator gap, apply 1 BID to the curved surface, overlapping the bottom tab skin by 1/2". Light model airplane fiberglass cloth works well for this application.
- G23. Sand the excess Clark foam from the inside of the tab. Lay 1 BID onto the inside surface of the bottom tab skin, wrapping it around the foam L.E. and onto the outside surface previously glassed.
- G24. Finish the trim tab by smoothing the curved foam area with micro. If you wish, you could block off the outboard edge of the trim tab with Clark foam and sand it flush so it won't bind at travel extremes.
- G25. Lay up one bid over the pop rivets on the trim tab and then body work the area for a smooth surface.



H. ELEVATOR TRAVEL STOPS

To provide positive stops for the elevator, you must form an E-glass bracket into which a threaded bolt will lock.

- H1. Raise the elevator to its full up travel limit of 26° . A Smart Level or dial type protractor is handy to check control throws, or you can use the Blueprint pattern gauge. Lock the elevator in this position with a piece of scrap wood and a blob of Bondo or instant glue.

NOTE: You will have to notch the trailing edge of the Horizontal. Stab. to attain full elevator travel. Do not notch any more than is necessary to get the proper deflection.

Travel Range

Fig. 7:H:1.

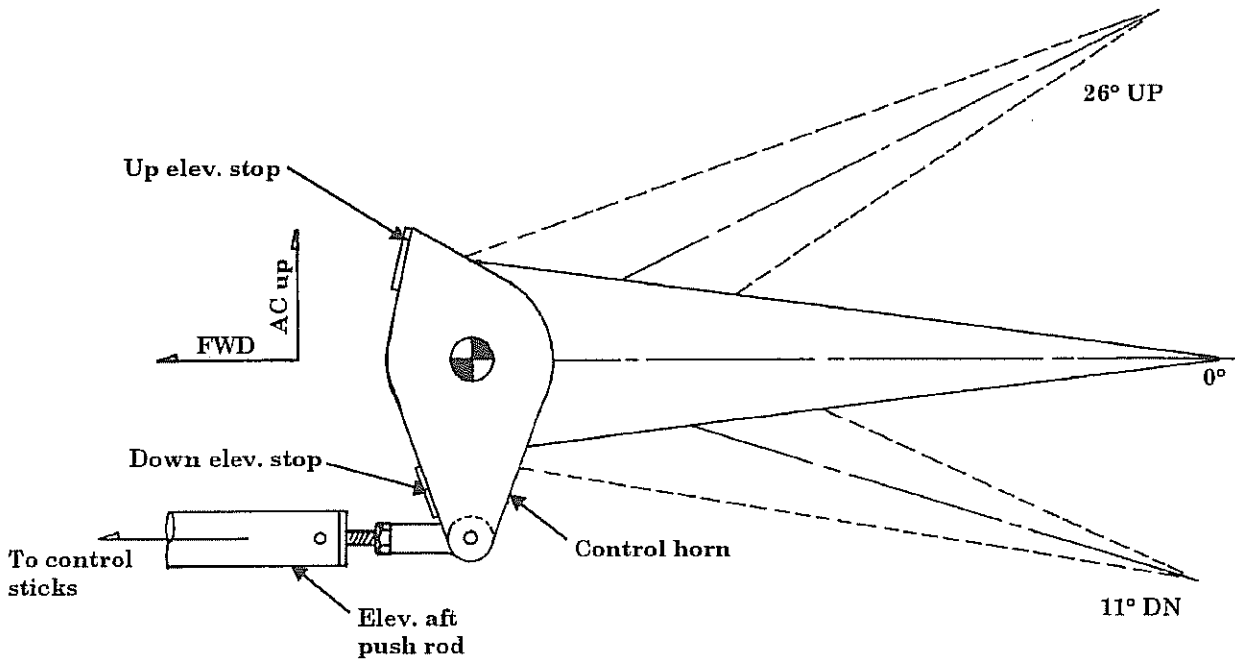

1. Cut a 1/4" x 3" x 2" piece of phenolic. Sand both sides of the phenolic thoroughly with 40 grit sandpaper. Also sand the bonding surface of the H. Stab.
2. Install the phenolic with Hysol™ or epoxy flox. At the same time, form a fillet around all sides of the phenolic for the 4 BID. Clean all bonding surfaces with MC.
3. Install a 4 BID to secure the phenolic.
4. Set the travel by grinding a notch in the phenolic.

Phenolic Travel Stop

Fig. 7:H.2.

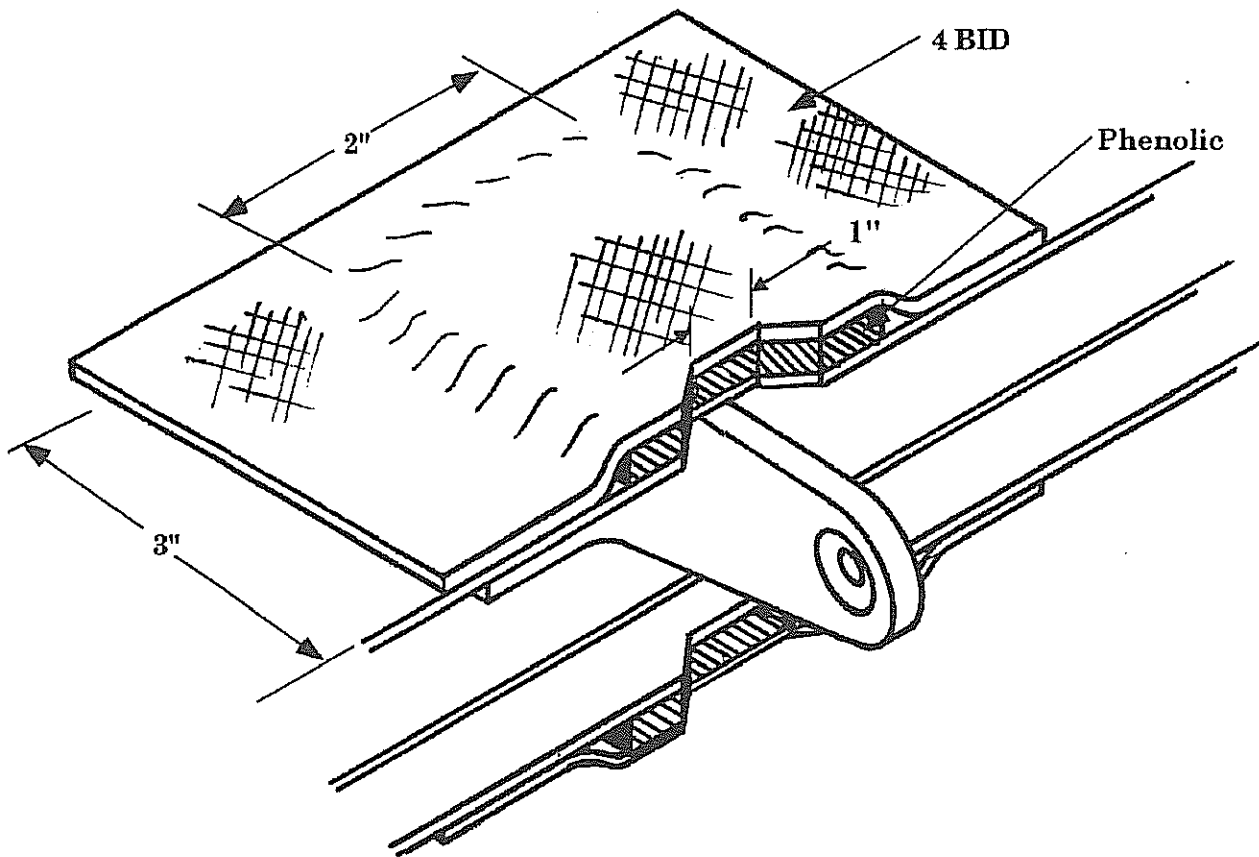



I. HORIZONTAL STABILIZER MOUNTING & BULKHEAD, VERTICAL STABILIZER SPAR

NOTE: You may prefer to move on to the wing assembly and come back to this chapter balance. In this manner, with the vertical tail not yet on the fslg, it is easier to position the fslg upside down.

Before mounting the horizontal stab, the fillets will require structurally stiffening. Also, the vertical stab stern post must be installed so that the high density foam block can be glassed into position (It would be inaccessible after the H. Stab. was installed).

I1. Level the fslg in the upright position. It must be level both spanwise and fwd to aft.

I2. Note that the fslg sides at the aft end where the V. Stab. spar or stern post installs should measure 2-3/8" to 2-1/2" at the lower portion of the fslg (measured 2" up from the base), see Fig. 7:I:1. It is necessary to establish this dimension early by simply cutting a block of wood and clamping in position to achieve and hold this dimension.

I3. Prior to mounting the H. Stab., the fillets will require stiffening.

NOTE: Before continuing, check to verify and establish that the fillets are properly aligned so as to position the H. Stab. correctly. Blueprint "G" has the H. Stab. alignment template, however we have found that a simple water level check is actually a better method.

The fillets are very flexible and require trimming in a scalloped manner so as to align with the stabilizer properly.

CORRECT HORIZONTAL STABILIZER INCIDENCE IS (-1/2° TO -1°)
This is perhaps most easily achieved by using water level differences between L.E. chord line and T.E. chord line.

I3.1 Locate the L.E. chord line as closely as possible at the most inboard location possible (i.e., against fuselage side). This will produce a chord length of 16.4" at approximately BL-4 (which is as close to centerline as you can get to measure).

I3.2. Draw a straight line aft that is parallel to the fslg centerline.

I3.3 Locate the T.E. chord line as closely as possible. This is a symmetrical airfoil section so simply locate a point that is vertically in the middle of the H. Stab. T.E. chord thickness.

I3.4 Now you can simply use a water level against the side of the fslg to set the incidence. You won't need the pattern cut out on the blueprint.

I3.5 The correct incidence range is when the L.E. of the chord line is 5/32" to 5/16" below the T.E. chord line as measured at a baseline point where the fslg fillets end.



Simply establish this relationship and the incidence will also be established.
 NOTE: On early MKII kits, the fillets will require trimming in a scalloped shape to accommodate the additional curvature of the H. Stab. Any other adjustments can be made up with the pad shape itself.

Use weights as required to hold the H. Stab. in proper alignment. Don't get too involved with this alignment yet, simply take it far enough to know that the proper alignment is attainable. That's good enough for now.

- I4. Cover the lower side of the H. Stab., over the joggled area, with plastic tape.
- I5. Construct a temporary dam on each side of the fsfg using any suitable material (cardboard, etc.) and cover with plastic tape as a release. Contour the top edge of the cardboard to fit against the H. Stab's lower surface so it is fairly snug.

Horizontal Stabilizer Fillet Pads

Fig. 7:I:2.

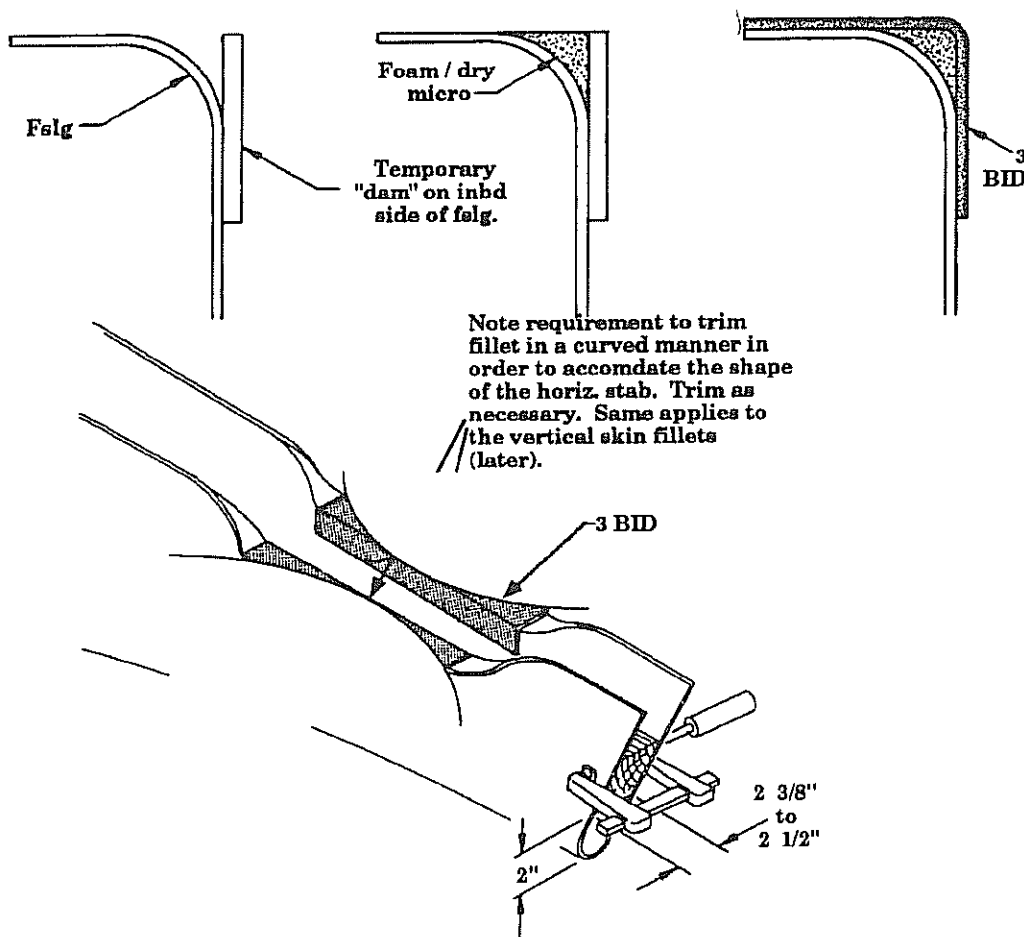

Horizontal Stabilizer to Fuselage Section

Fig. 7:I:3.

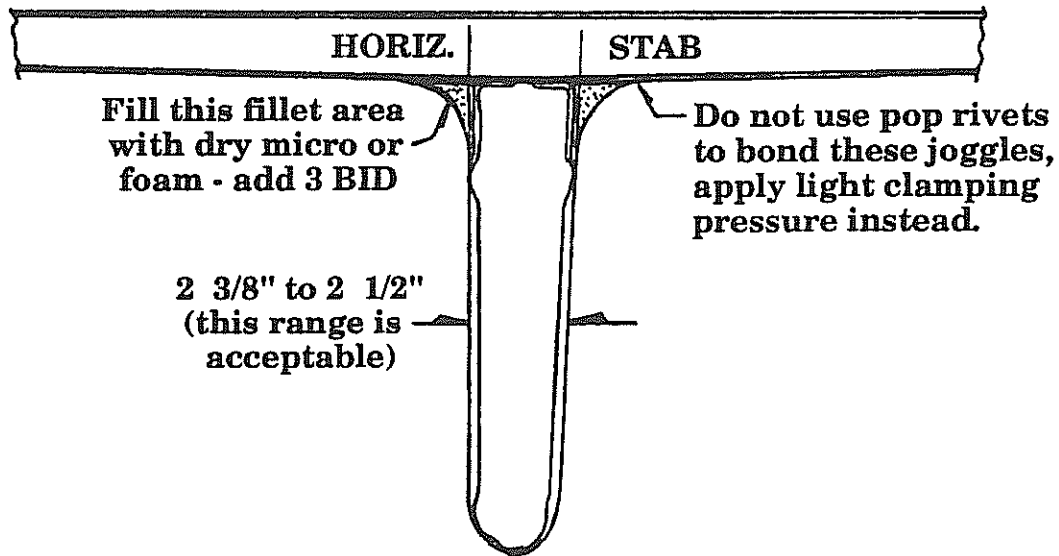

- I6. Position the cardboard and fill in the resulting triangular area with dry micro. The cardboard can be taped in place. Now place the H. Stab. on top of this and establish the proper incidence and span wise level of the stabilizer. Use weights to hold it in place until the micro cures.

In this manner, you will form the micro to the proper contour to later accept the Stab. After cure, recheck the H. Stab. alignment and adjust if necessary by sanding or filing on the micro pads. Note that these pads will receive a 3 BID overlay but that will not alter the alignment.

- I7. When the alignment is verified as correct, add the 3 BID (see Fig. 7:I:1). Overlap 1-1/2" onto the fslg interior sides.

J. VERTICAL STABILIZER SPAR

J1. Per Fig. 7:J:1, construct the V. Stab. spar (or stern post). It requires 2 BID per side initially with an inner (fwd side) 2 BID attached plus one additional BID (or 3 BID total) from the base up to 22". The aft side will attach with 3 BID. Note that the stern post is 28° as in Fig. 7:J:1. In the figure the fwd to aft position of the stern post is illustrated. Note that it is relatively tolerant of position. Adequate clearances must be maintained between elevator, elevator control horn and stern post.

J2. Flox the V. Stab. spar (stern post) into position having checked for square condition. To do this:

- a. Check again that the fslg is level in both directions.
- b. Drop a plumb bob down to the floor from the center line at the firewall and the center line of the fslg at the lower tail area.
- c. Draw a straight line or snap a chalk line on the floor between the two points and extend that line aft a couple of feet.
- d. From the top center tip of the V. Stab. spar, drop a plumb bob and align it with the line on the floor which is the fslg center line. This will assure that the spar is truly vertical.

Bond and clamp the V. Stab. spar to the vertical sides of the fslg at this time.

NOTE: After you have bonded the V. Stab. spar into position, place two straight edges along the side of the fslg and clamp in position while the floc cures. This will assure that the side areas there will come out straight. Otherwise a slight bow could result and the rudder would not fair in smoothly.



Vertical Stabilizer Spar

Fig. 7:J:1.

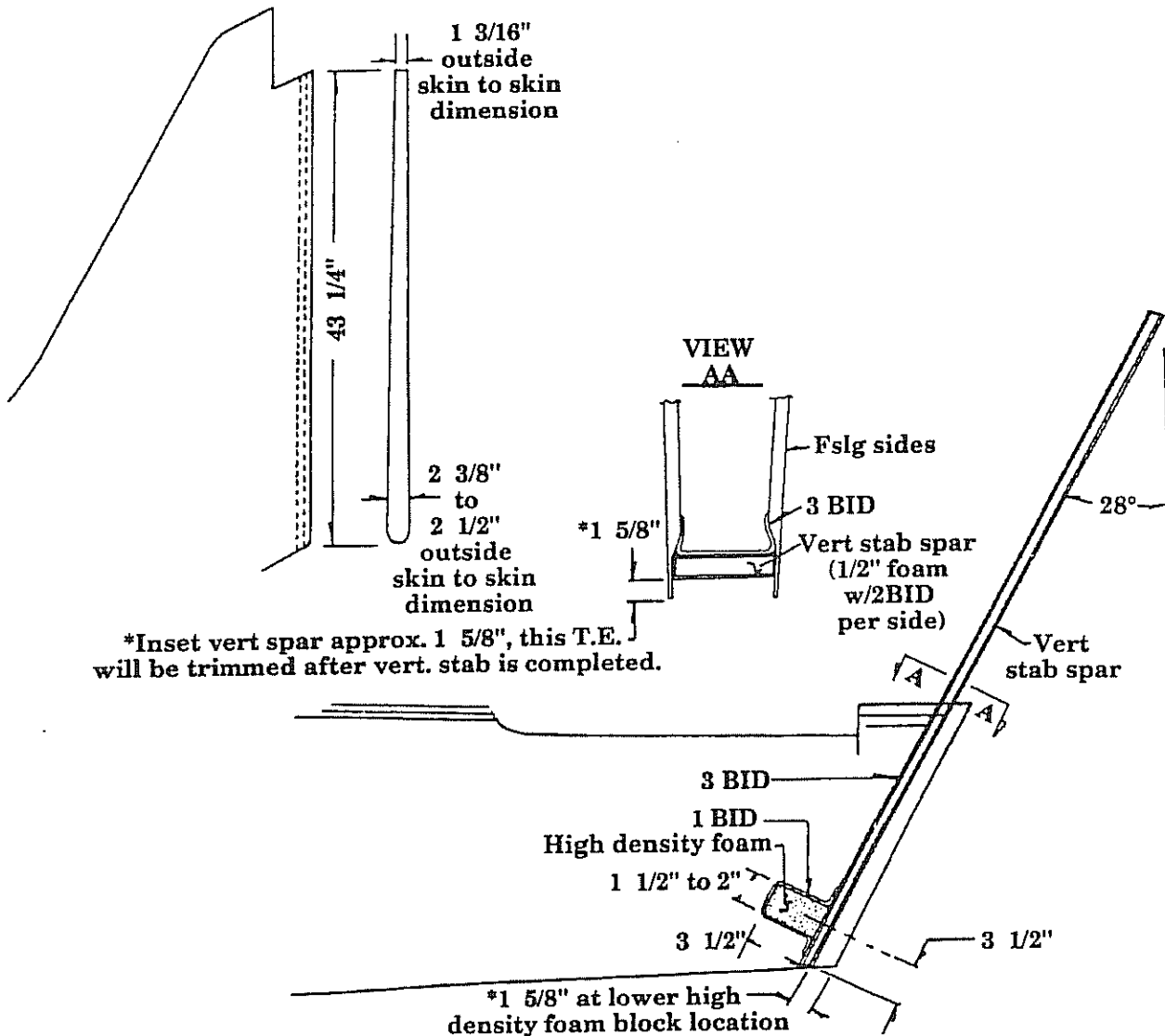

- J3. Add 3 BID along the inner junctures of the fslg to the V. Stab. Spar. Do NOT add the outer (aft side) 3 BID yet, they will be added when the whole vertical fin is attached.
- J4. Add the high density foam block which will accept the lower rudder pivot assembly (see Fig. 7:J:1). This block should fit snug against each fslg side skin. Add 1 BID around it which will also roll up onto the fslg sides approx. 1". On the outside of the fslg, mark the location of the high density foam for later reference. Prefit the rudder to help locate the position of the foam blocks.

K. HORIZONTAL STABILIZER FORWARD BULKHEAD

This bulkhead should be traced from blueprint "C". It will be positioned at the fwd leading edge of the H. Stab. It will also extend up into the vertical fin sides but don't be concerned with that aspect yet. It is best to leave a little extra "trim stock" above the H. Stab. for now.

- K1. This bulkhead will be 1/2" core with 2 BID per side (or 3/8" x 2 BID per side prepreg). The fwd bulkhead will incorporate a 30° aft "lean" and bump up to the fwd edge of the H. Stab.
- K2. Make the ctr cutout for the elevator pushrod and make a glass to glass seam around the circumference.

NOTE: Before bonding this bulkhead into position, it is advisable to install the rudder cable guide tubing (ref. blueprint "H"). For now, drill through the small fillets on the fslg sides and insert the tubing through to the exterior. It should run snug to the fslg as it exits at the fairings. On the inside, extend the tubing fwd past the bulkhead position on a line that aims toward the baggage bulkhead bottom ctr position. Use hot or instant glue to hold the tubing (3/16" Nylo-flo) against the fslg sides temporarily. Place 1 BID over to bond into permanent position. Now the two upcoming bulkheads can be installed over this rudder guide tubing.

- K3. Bond the bulkhead into position with epoxy/flox and add 2 BID (2" wide) around the perimeter on both fwd and aft faces.

Horizontal Stabilizer Bulkheads

Fig. 7:K:1.

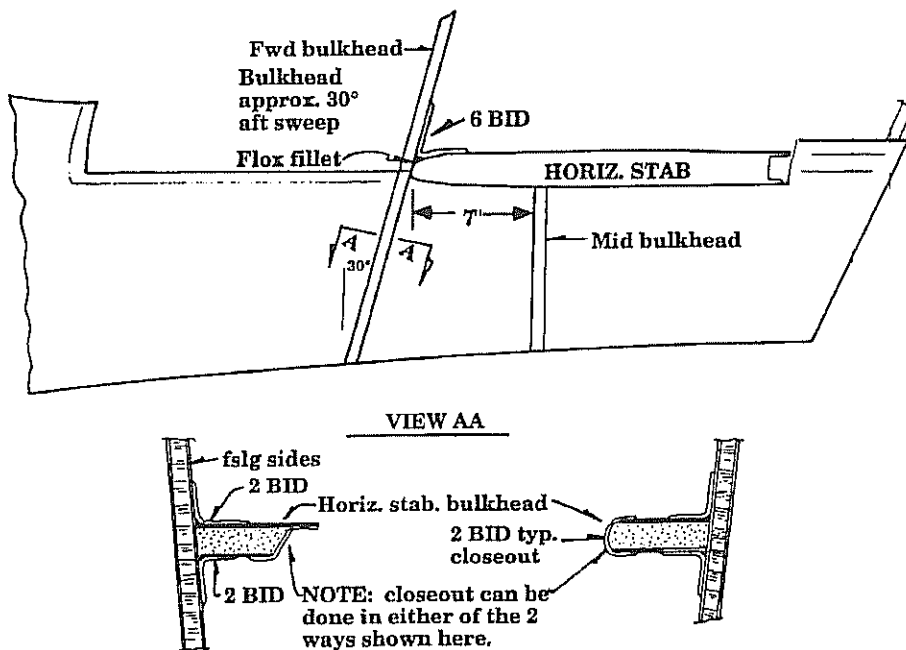



- L. **HORIZONTAL STABILIZER MID BULKHEAD**
This bulkhead will position at approximately the 25% of chord position under the H. Stab. It will, in a like manner, be constructed as the fwd bulkhead has been, i.e., 1/2" core plus 2 BID per side or 3/8" core plus 2 prepreg BID per side.
- L1. From Blueprint "C", trace out and construct this bulkhead.
- L2. Make the ctr cutout for the elevator pushrod and make a glass to glass seam along the circumference.
- L3. Locate the position (7" aft of the H. Stab. L.E. position measured at BL-0) and fit into the fslg.
- L4. Bond in position with 2 BID on fwd and aft faces.
- L5. Grind the upper edge down to mate with the lower surface of the H. Stab.
- L6. Drill 1/8" drain hole just behind the aft face through the fslg bottom ctr.
- L7. The fwd face of this bulkhead is an ideal location for a tail tie down. If you're going to add that, now is the time- or at least before you attach the H. Stab. See the wing tie down installation in Chapter 9 for a suitable approach to this tiedown.



M. HORIZONTAL STABILIZER FINAL BOND TO FUSELAGE

- M1. Position the H. Stab. on the built up fillets and recheck the alignments (see Fig. 7:M:1).
- Check for spanwise centering on fslg ctr line.
 - Check for spanwise level. Use either a long carpenter's level on the upper T.E. or use a water level at respective locations at the tips.
 - Check for proper sweep. Measure from tip to BL-50 main spar tips.
 - Check for proper incidence using the template on blueprint "G". If a correction is required, use flox to shim as necessary.

NOTE: The template will establish an incidence of $(-1/2^\circ)$.

Horizontal Stabilizer Alignment to Fuselage

Fig. 7:M:1.

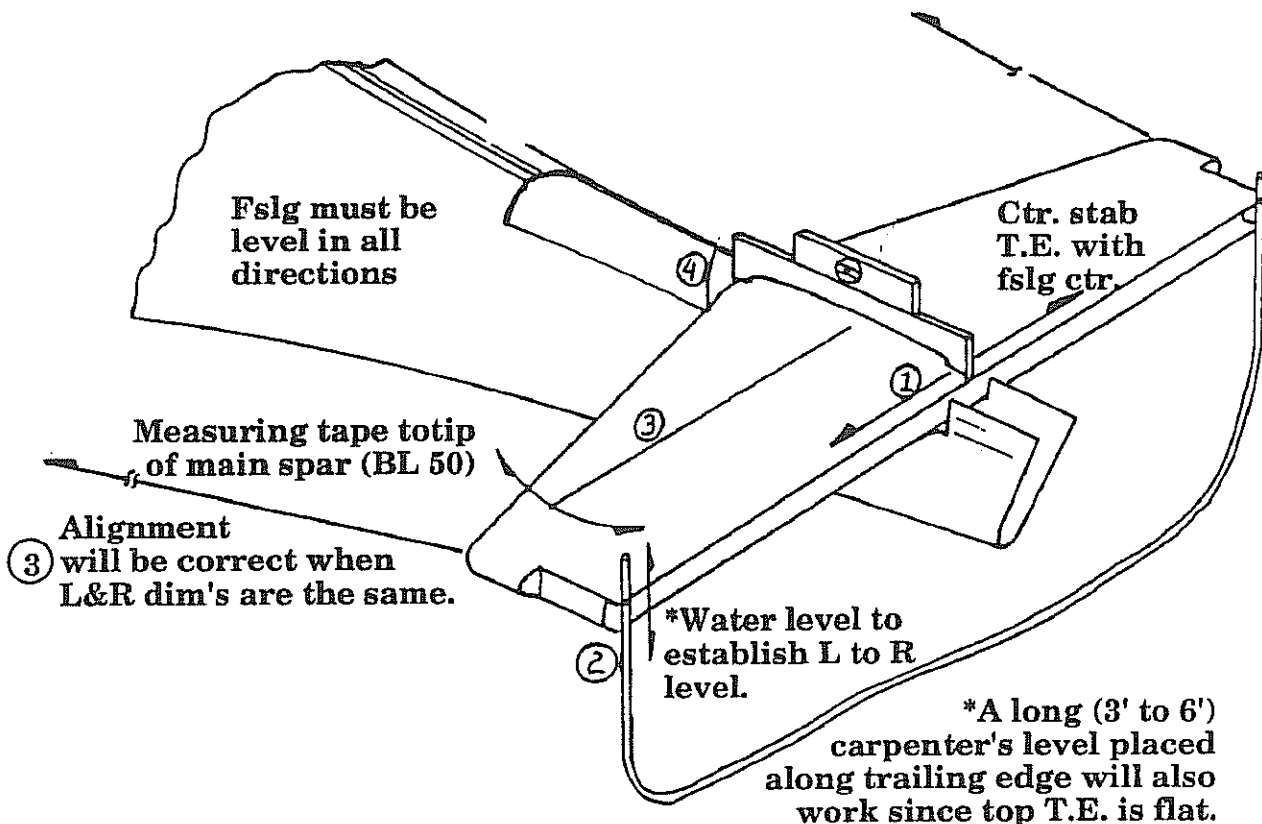

- M2. Bond the H. Stab. down into the fillet pads using structural adhesive with 10-20% flox added. Use weights to apply pressure during cure. You can also attach with one cleco at each aft side and one cleco at each fwd side (Do not use pop rivets at the fwd side).

- M3. After cure, add 2 BID to the under side where the joggles are and also on the interior side between the fwd and mid bulkheads. This bulkhead can easily be reached from the fwd side.
- M4. Add the 6 BID layup at the L. E. top of the H. Stab. where it meets the fwd bulkhead (see fig. 7:M:2).

Horizontal Stabilizer/Forward Bulkhead Joined
Fig. 7:M:2.

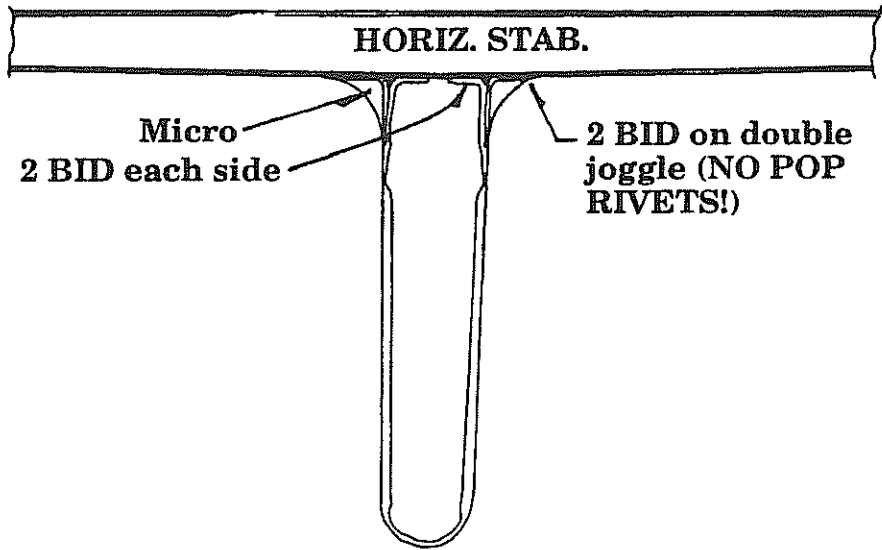

✓

⊗

CHAPTER 8: VERTICAL STABILIZER AND RUDDER

REVISIONS

From time to time, revisions to this assembly manual may be deemed necessary. When such revisions are made, you should immediately replace all outdated pages with the revised pages. Discard the out dated pages. Note that on the lower right corner of each page is a "revision date". Initial printings will have the number "0" printed and the printing date. All subsequent revisions will have the revision number followed by the date of that revision. When such revisions are made, a "table of revisions" page will also be issued. This page (or pages) should be inserted in front of the opening page (this page) of each affected chapter. A new "table of revisions" page will accompany any revision made to a chapter.

Arrows

Most drawings will have arrows to show which direction the parts are facing, unless the drawing itself makes that very obvious. "A/C UP" refers to the direction that would be up if the part were installed in a plane sitting in the upright position. In most cases the part shown will be oriented in the same position as the part itself will be placed during that particular assembly step. However, time goes on and changes are made, so careful attention should be paid to the orientation arrows. That old cartoon of the guy agonizing over the plans for his canoe, built one end up, one end down, should not happen in real life. Especially to you.

CONTENTS

1. INTRODUCTION
2. DRAWING LIST
3. SPECIAL PARTS, TOOLS & SUPPLIES LIST
 - A. PARTS
 - B. TOOLS
 - C. MATERIALS & SUPPLIES
4. PROCEDURE
 - A. RUDDER ASSEMBLY
 - B. RUDDER COUNTER BALANCE WEIGHTS
 - C. VERTICAL STAB ASSEMBLY
 - D. RUDDER PIVOT ASSEMBLY
 - E. SETTING THE PIVOT PIECES ONTO THE VERTICAL STABILIZER
 - F. SETTING THE RUDDER PIVOT PIECES INTO THE RUDDER
 - G. RUDDER TRAVEL STOPS
 - H. SECURING RUDDER

1. INTRODUCTION

Covering the assembly of the vertical portions of the tail, this chapter is relatively brief and simple to get through. The rudder will be built and counter balanced, and the vertical stabilizer will be constructed and attached to the aircraft.

NOTE: If you are planning on installing any antennas such as Loran, etc., that will be mounted within the tail, now is the time to get those parts together.

Vertical stabilizer and rudder

Figure 8-1

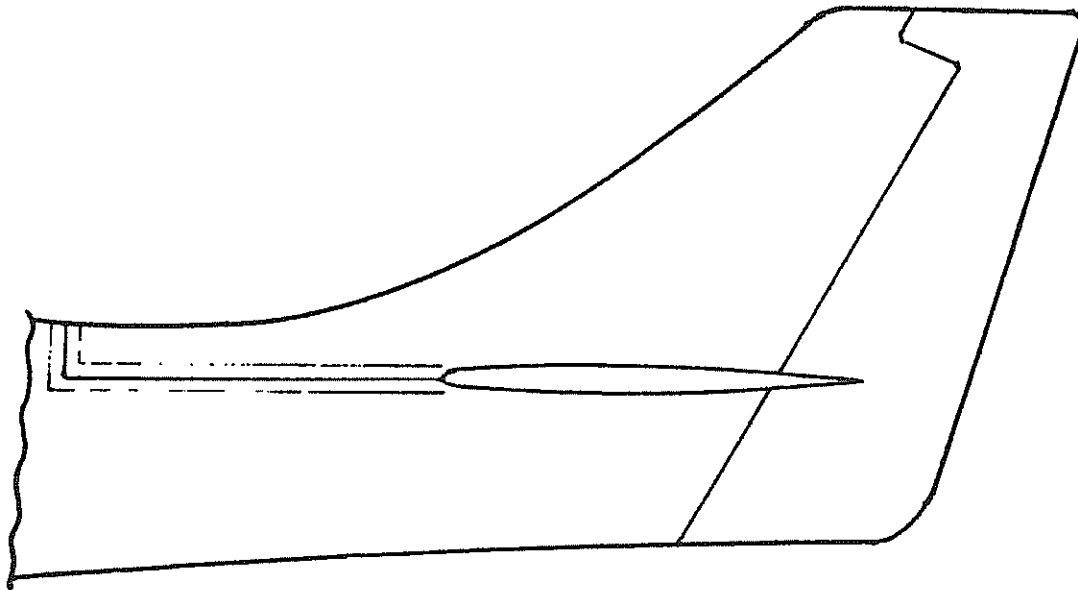

2. DRAWING LIST

8-1	page	8-2	Vertical stabilizer and rudder
8-2		8-7	Rudder side view
8-3		8-11	Attaching additional counter balance weights to rudder
8-4		8-12	Vertical stabilizer
8-5		8-13	Establishing plumb condition of the vert. stab. spar
8-6		8-15	Attaching vertical stab and H. stab
8-7		8-16	Vertical stab / rudder
8-8		8-17	Vertical stab attach
8-9		8-19	Closing vertical stabilizer
8-10		8-20	Elevator travel limits
8-11		8-21	Fitting in rudder
8-12		8-22	Rudder pivot pieces
8-13		8-23	Typical rudder pivot assembly
8-14		8-24	Rudder pivot pins
8-15		8-26	Spacing the lower pivot pc using shims
8-16		8-28	Rudder pivot cross sections
8-17		8-31	Lower rudder pivot / control horn
8-18		8-32	Upper rudder pivot
8-19		8-33	Establishing rudder travel
8-20		8-35	Safety wiring rudder pivot bolt retention tube



3. EQUIPMENT REQUIRED - SPECIAL PARTS, TOOLS & SUPPLIES

A. Parts

- Rudder pivot hardware
- Left rudder skin
- Right rudder skin
- Left vertical stabilizer skin
- Right vertical stabilizer skin



8-4

Chapter 8	REV. 0 / 11-1-91
VERTICAL STABILIZER AND RUDDER	



B. Tools

- rib and spar templates from blueprints
- Band saw or sabre saw
- Rivet squeezer or equiv.
- Transfer punches or equiv.
- Dremel™ type rotary grinder
- Drill motor
- Drill bits:
 - 3/8"
- Plumb bob
- Carpenter's level
- C-clamps (3" is sufficient)
- Communications antenna (optional)
- Tail navigational light (optional)



C. Materials & supplies

- epoxy
- flox
- BID cloth
- micro
- 1/4" foam
- 1/2" foam
- 1" thick high density foam
- structural adhesive
- pop rivets (approx. 40)



4. PROCEDURE
 A. Rudder assembly

1. Select either side of the rudder and locate the rib positions per figure 8-2.

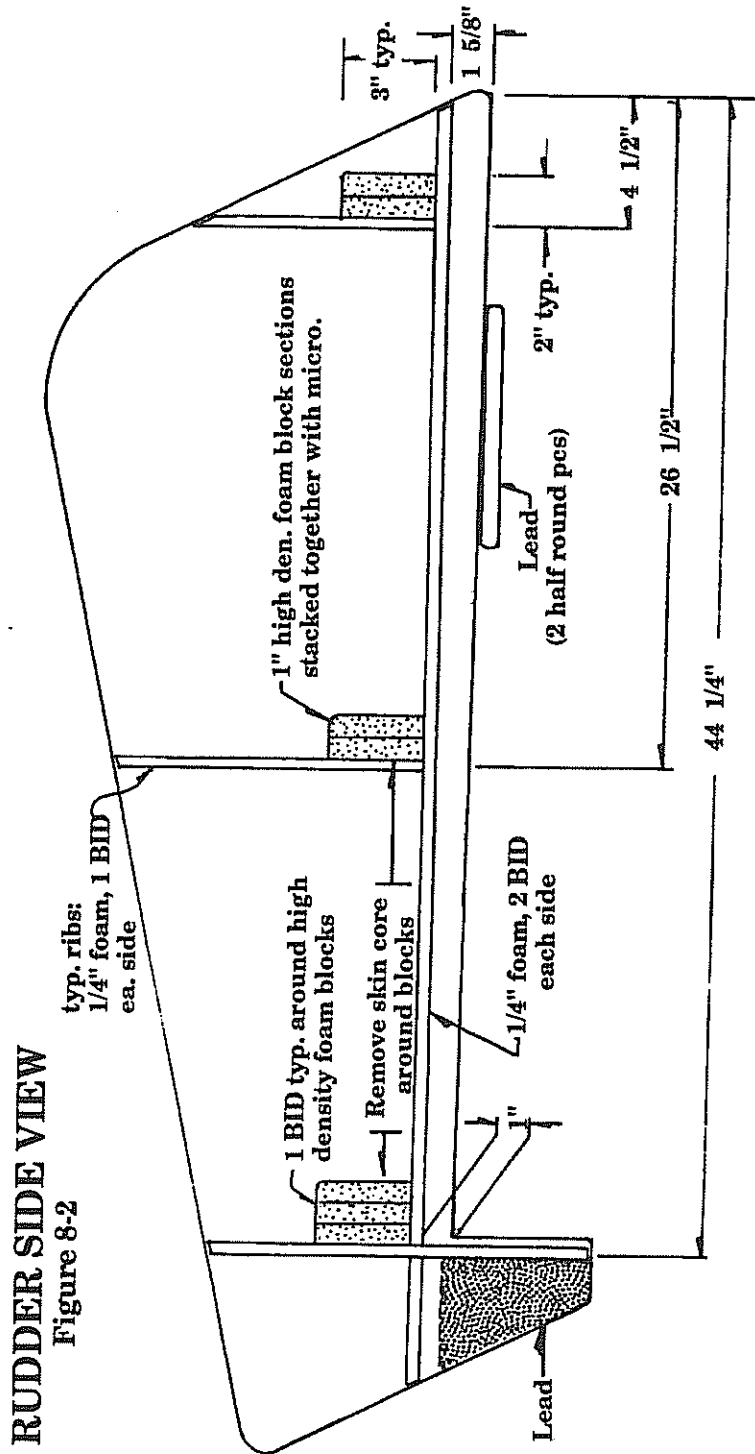

RUDDER SIDE VIEW
 Figure 8-2



NOTE: It is best to NOT remove the "flash" from around the sides of the rudder halves yet. They will help to align the halves and provide a slight bondable edge to hold the pcs prior to applying the bonding tapes to the exterior joggles (similar to the approach used for the horizontal stab). Also, there are two acceptable methods for fabricating the internal ribs. They can be cut from either 1/4" foam with 1 BID per side or from the 1 ply prepreg honeycomb sheet. The other method may prove lighter and possibly easier; with this method you simply cut the ribs from 1/4" foam and lay up a single BID per side which both attaches to the skin and forms the 1 BID side of the rib.

2. First cut and fit the rudder spar. This requires 2 BID per side.
3. Micro the spar into position. See figure 8-2.
4. Cut the ribs out based on your chosen method (see above note).
5. Sand the ribs to achieve a good alignment to the skin.
6. Use micro to attach the ribs to the first rudder skin. Allow to cure.
7. Now sand the other edge of the spar and ribs to achieve a good fit to the close out skin.
8. Fit the lower high density foam block into the rudder per figure 8-2. This block will fit ONTO the foam core of the rudder halves.

NOTE: It is important that you position the lower foam block correctly so as to align properly with the block already established in the lower fslg tail section. The centerline of the rudder block should be 1/4" above the centerline of the fslg block for best fit.

9. Fit the middle and upper foam blocks per figure 8-2. These blocks must fit INTO the foam cores of the rudder halves. This is to allow sufficient room for the rudder pivot pcs to be potted later.
10. Use micro to pot the high density blocks into position.
11. Add 1 BID around these blocks, contact 1" onto the rudder skins. Do not add more fiberglass thinking it will be stronger. The added weight will make it difficult to balance.



12. After the above cures, sand down to a good fit against the remaining rudder half. Note that the remaining rudder half will require the core removal where the two upper high density foam blocks are installed. Be sure that there are no "voids" around the high density foam blocks where they contact the skins.

NOTE: Be sure to mark the locations of all three high density foam blocks on the outside of the rudder for later reference.



8-9

Chapter 8

REV. 0 / 11-1-91

VERTICAL STABILIZER AND RUDDER



B. Rudder counter balance weights

1. Into the upper fwd area of the rudder (the part that swings through the vert. stab.), four (4) pounds of lead must be added. It is important to keep the lead as far forward as is possible to achieve the most advantageous balance effect. Using the half round lead bars, cut them to nest tightly into the area of the rudder halves. The core material termination will vary slightly from part to part but generally, there is sufficient room to tightly nest these pcs without removing core material.
2. When you have the lead fitted into position, remove and "POT" it in permanently with micro. Use a slightly wetter micro mixture than normal so that it can run down between pcs and pot everything in securely. Allow to cure.
3. You're now ready to permanently bond the rudder halves together. Use epoxy/flox in a manner similar to that used for the horizontal stab. As usual, be sure that all surfaces are cleaned well prior to bonding.

When bonding the L.E., use a little epoxy/flox along the edge and onto the "flange" material that was left on, this will provide a means of holding the alignment until the BID tapes are added. Be sure to clamp a straight edge (or flat table top) to hold the T.E. alignment during cure.

4. When the part has cured, trim off the "flash" material and add the 2 BID around the L.E. where the joggles are.
5. Additional counter balance weights are required on the L.E. of the rudder between the middle pivot and the lower pivot positions. These two half round lead bars can not be added until the vertical stab is completed so that a clearance check can be made.
6. When the vertical stab is completed and all pivot hardware is fitted, fit two half round lead bars (full length) to the L.E. of the rudder between the lower two pivot positions. Locate their centers 1/8" right of the rudder centerline (i.e., 1/8" towards the passenger side when installed). This is to ensure clearance for the full 30°s right rudder. The left rudder only requires 25°s.

Use hot glue or instant glue to quickly attach these pcs and make a fit check through full rotations. When the fit is established as o.k., place a micro fillet between lead and rudder and lay 2 BID over these lead pcs thus attaching them to the L.E. of the rudder. Contact the rudder with at least 3/4" of BID each side.



Attaching additional counter balance weights to rudder

Figure 8-3

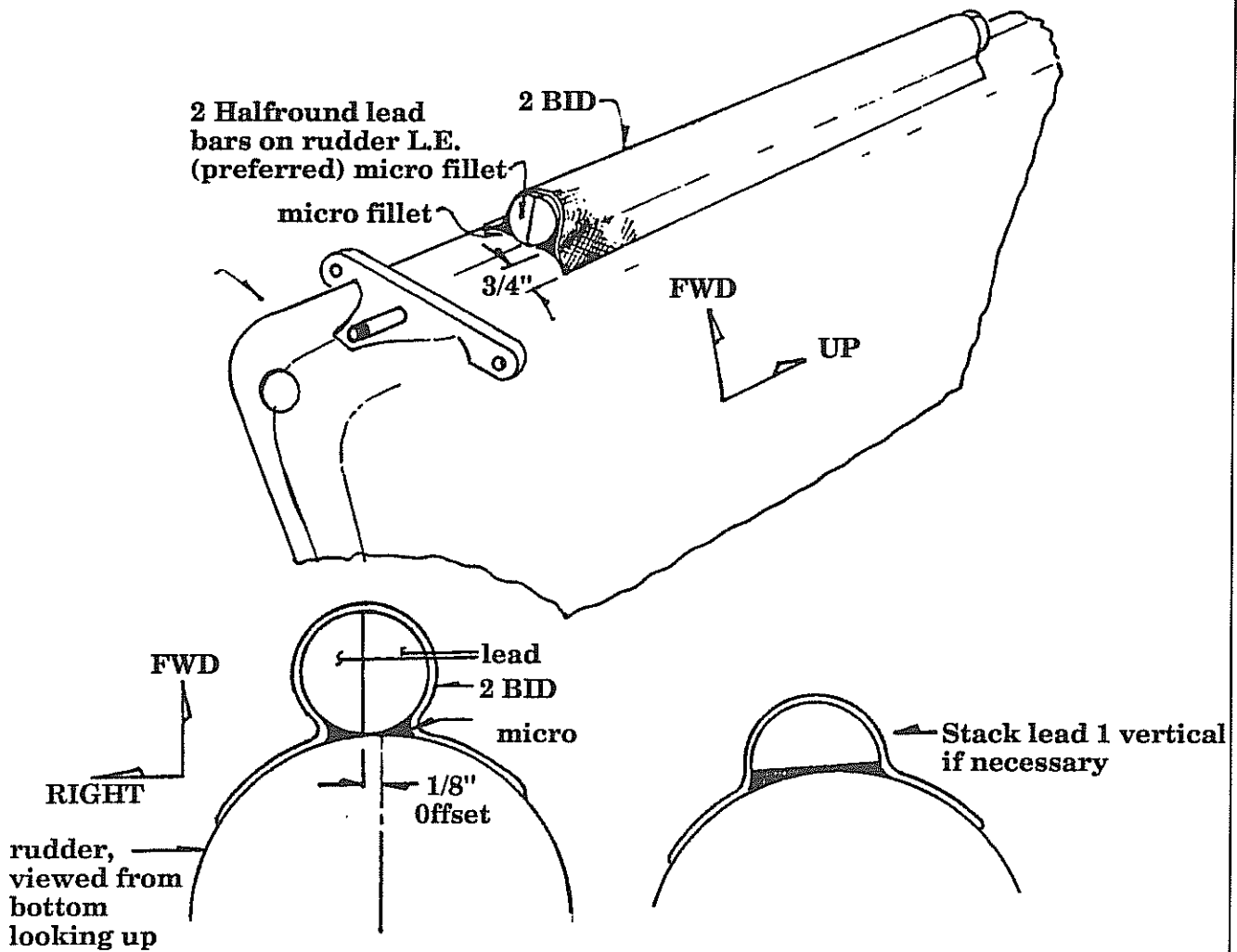

NOTE: If your particular installation is tight, you may not be able to position the lower two lead half-rounds as shown. It is acceptable to install singular half-rounds and stack the two along the fwd rudder L.E. skin line.

C. Vertical stab assembly

This assembly is straight forward and quite simple. If you are intending to carry a loran antenna, the L.E. of the vertical fin is the best location. Also, a comm antenna can be installed into the vertical fin.

Vertical stabilizer

Figure 8-4

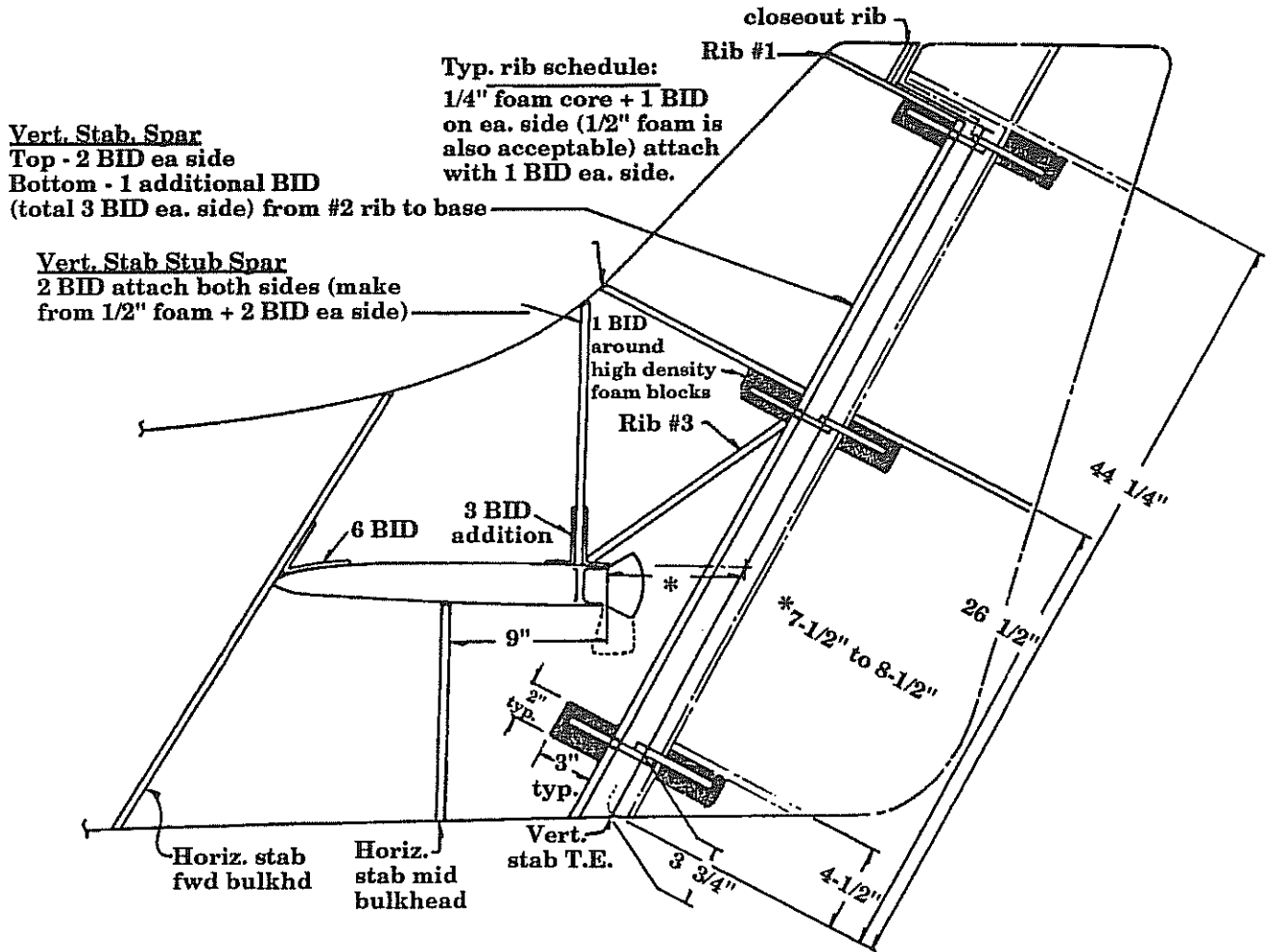

1. Level the fslg in both directions. Fslg should be upright.
2. Trim and fit one of the vertical fin sides to the fslg. The joggles will fairly well dictate position. Don't worry about the T.E. at this time, it will be trimmed to a straight line later.

3. For the initial fit, set one or two clecoes at the fwd edge of the vert stab skin and one at the T.E. You can also set one through the T.E. area of the H. stab skin and one at the L.E. of the H. stab upper skin.

NOTE: Prior to bonding the vert stab skin (next step) check to verify and reestablish the "plumb" condition of the vert stab spar.

Establishing plumb condition of the vert stab spar

Figure 8-5

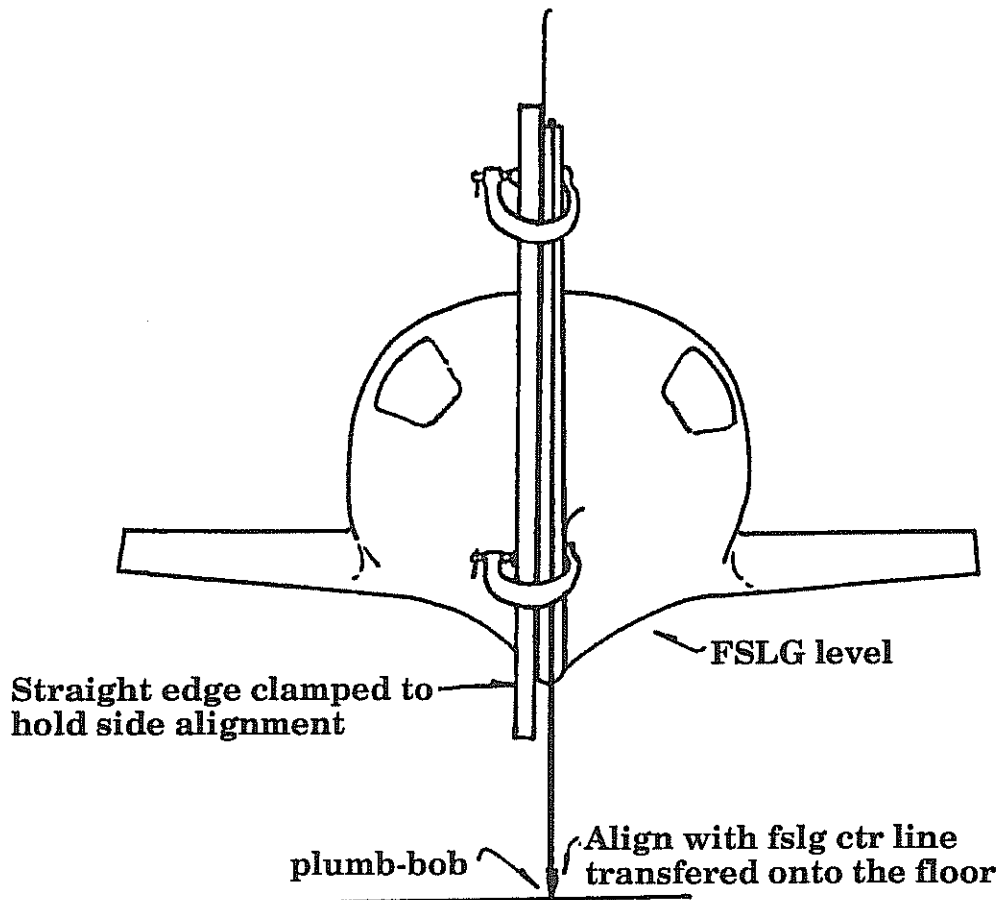

4. With the vertical stab "plumb" condition reestablished, the skin can be drilled for all attaching pop-rivets along the joggle. Fit the fwd H. stab bulkhead to mate with the vertical stab skin.

5. Clean all surfaces and bond in position. Use structural adhesive along the joggles and epoxy/flox along the vert stab spar and H. stab bulkhead. Clamp in position and allow to cure.

NOTE: During cure, place a long straight edge from base of fslg up to top of vert stab skin. Clamp with C-clamps, spring clamps or equiv. thus assuring a straight line along this surface.

NOTE: Do not set pop rivets into the H. stab since the drilling out process would allow them to drop down into the stab. Use clamps, weights or clecos.

6. After cure, remove the clamps and add 2 BID along the inside or fwd face of the vert stab spar to skin juncture. Contact 1-1/2" onto the skin and run full width of the spar.
7. Add one additional BID to the lower 27" of the spar to skin juncture, see figure 8-4.
8. Add 1 BID along the juncture of the vert stab and the H. stab. This is in the rolling fillet area and will thus require a generous micro fillet. Keep the micro dry.
9. From blueprint "C", cut out the pattern for the vert stab ribs (3) and the stab spar.

NOTE: If you are intending to add any antennas, now is the last time available.

10. Fit the stub spar into position and attach with micro. Add the 2 BID attach full height and 3 BID additional to the lower 6". Contact 1-1/2" onto the top of the H. stab.
11. Fit the three rib sections and attach with micro. Add the 2 BID tapes to all sides. Allow to cure. Also fit the two remaining high density foam blocks. They must be in alignment with the blocks in the rudder. Position the rudder as closely as possible and mark the location. Ideally, the center line of the rudder blocks will be 1/4" higher than that of the blocks in the vert stab. But, there are adequate margins to allow for some position error.



Attaching vert stab and H. stab

Figure 8-6

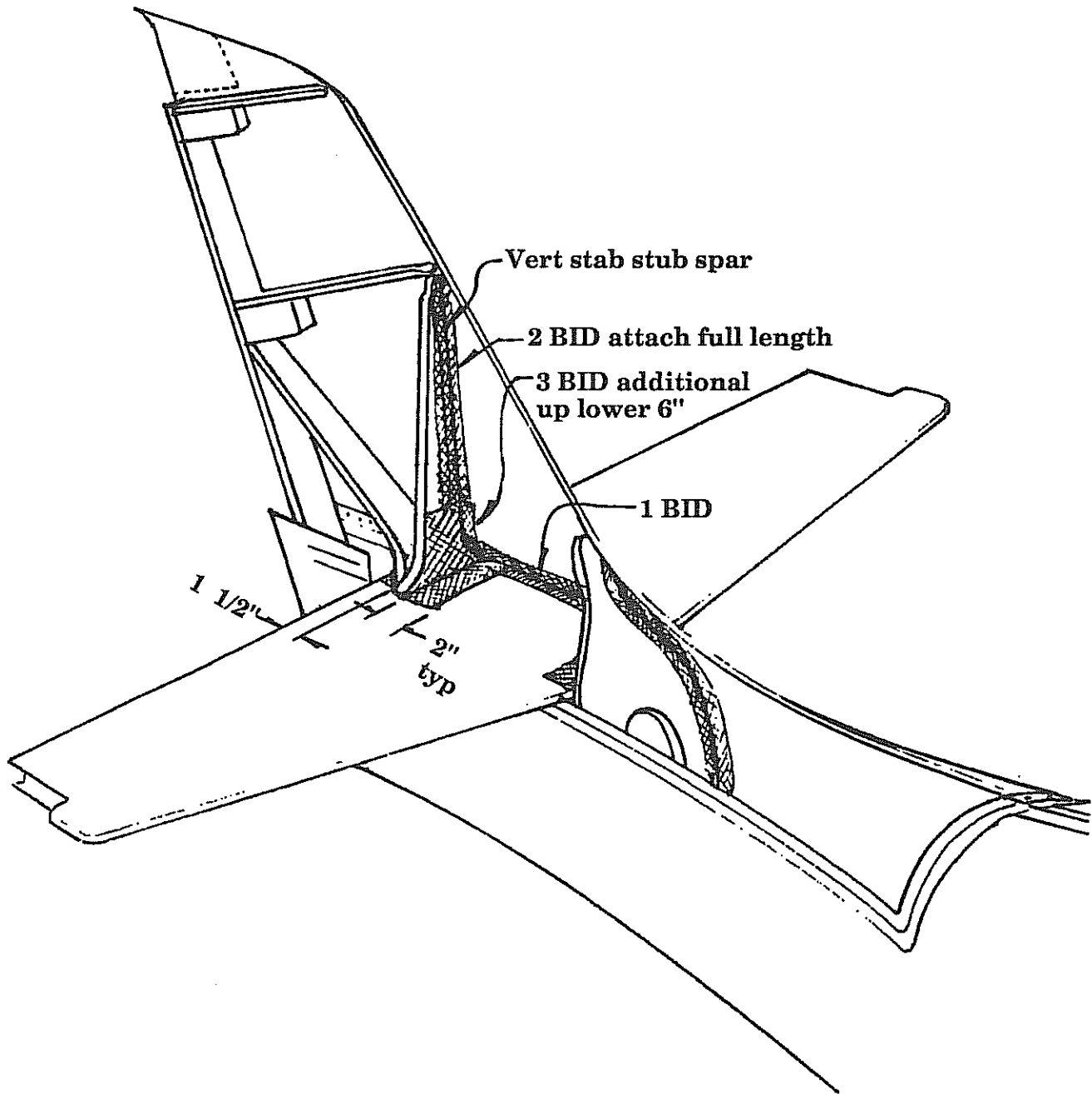

Vertical stab / rudder
 cross sectional view, looking down from top
 figure 8-7

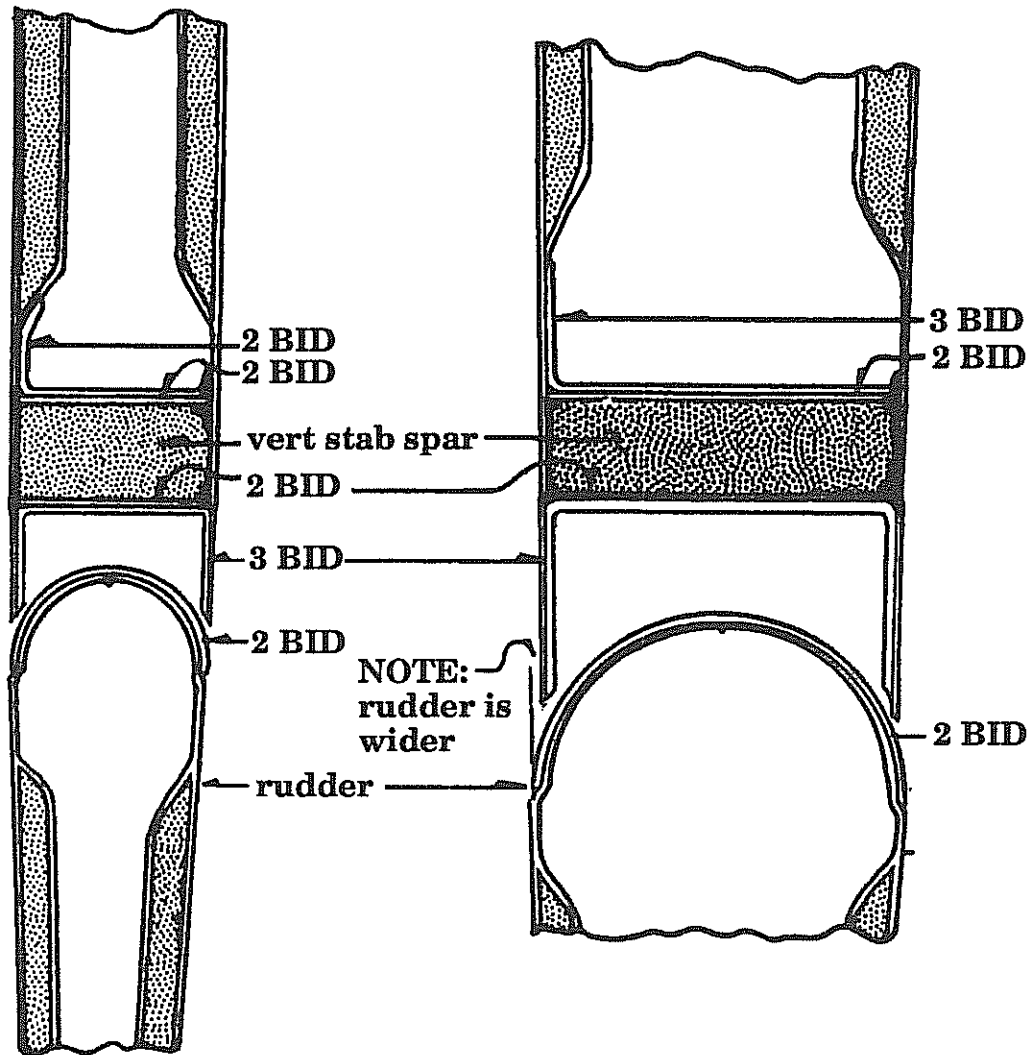

12. Now you're ready to fit the remaining stab skin. Position it in a similar manner as with the first side. Sand the ribs as required to get a good fit. You can check fit by setting a couple of clecoes and cracking it open just enough to see inside thus noting any conflicts of fit.

13. Mark all the rib, spar and foam block locations as a reference onto the remaining stab skin. Remove the skin and place wide strips of plastic tape over the areas where the ribs, spars and foam blocks will eventually bond. Allow plenty of over run with the plastic tape so that if the flox spreads, it won't get prematurely stuck to the stab.
14. Prep the ribs, spars and foam blocks for acceptance of the epoxy/flox mixture by grooving into the edges. You want to get 1/8" contact onto the INNER faces of the rib and spar skins.
15. Now add a generous amount of epoxy/flox to the edges of the ribs, spars and foam blocks to be mated.

Vertical stab attach

Figure 8-8

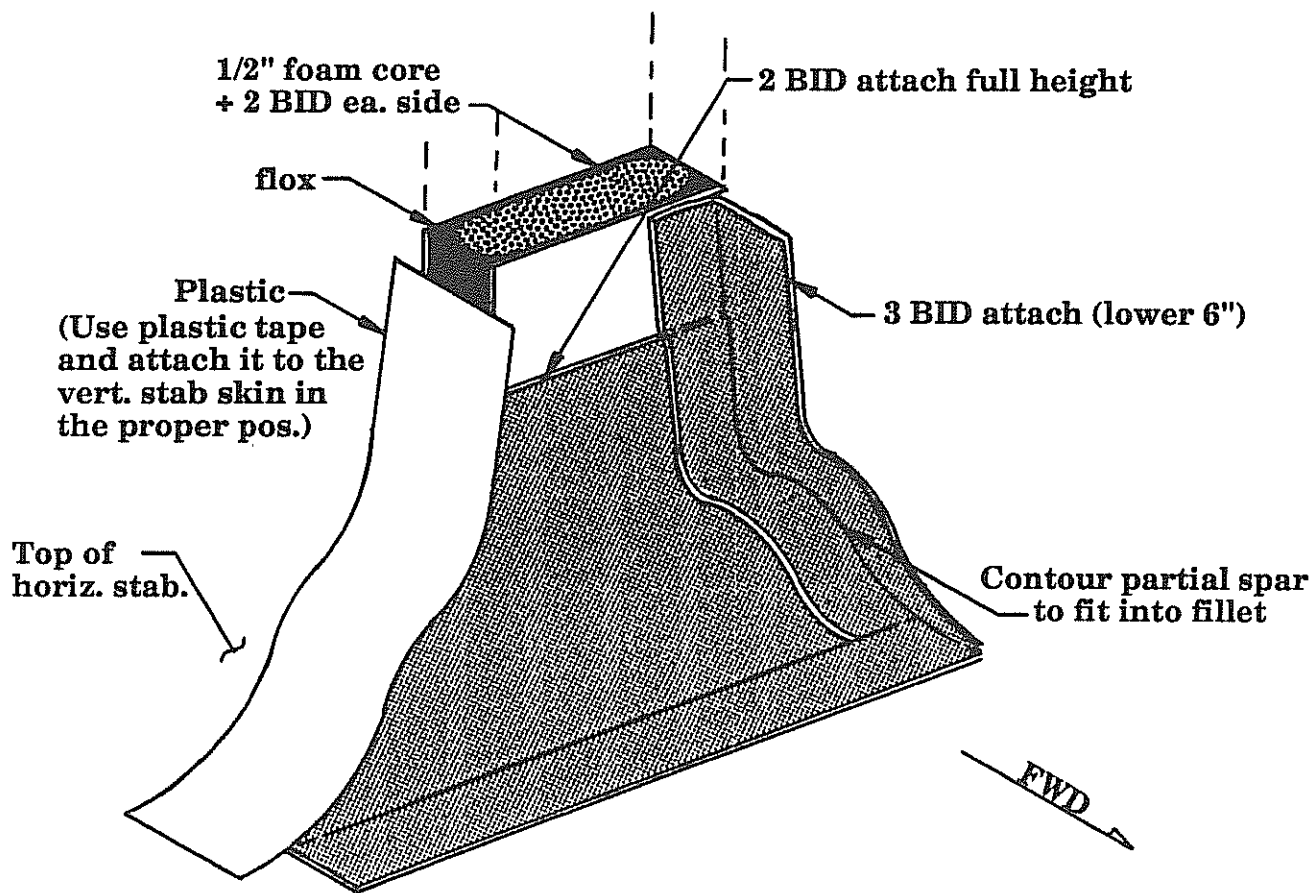

16. Reposition the remaining vert stab skin and clamp lightly into final position. You should get a good squeeze out of flox along all the bonding surfaces. This excess can be trimmed off later when the skin is removed. The plastic tape will prevent the epoxy/flox from bonding to the skin and after removal of the skin, a perfect mating surface will be the result.

NOTE: During cure, check that the vert stab is "true". That is to mean that it should be aligned straight with the centerline of the fslg. There is no built in offset so if you detect an offset, it should be clamped in such a manner as to remove it.

It is easiest to check this alignment by running a string line from top T.E. of the vert stab to a point straight up from the firewall centerline. Then sight down this line and check the left to right alignment of the vert stab itself. If a twist is seen, it can be taken out with clamping action.

17. After the epoxy/flox on the ribs and spars has set up, the skin can be removed and all excess epoxy/flox can be trimmed off. If it is fully cured, use a heat gun to soften it and then trim with a sharp matt knife. If there are any areas where contact was not made, then they can be filled in. If they are shallow areas, just add additional adhesive with a little flox filler to those areas. If they are deep (over 3/32") then you should build them up using the fit-and-release method prior to permanently bonding the skin on.
18. Mark the locations of the high density foam blocks onto the outside of the vert stab skin.
19. When the fit is right, prepare the surfaces for bonding and spread a smooth coating of structural adhesive to all surfaces being bonded. Adhesive must be spread on both the vert stab skin and to the ribs, spars and foam blocks and to the joggles.
20. Position the vert stab skin in final bonding position. Set all pop rivets along the joggles and clamp along the T.E. using a long straight edge to achieve a straight line between fslg and vert stab skin, clamp and allow to cure.
21. The L.E. of the vert stab should be held in position with duct tape or equiv. Add into the joggle three or four small sections (about 2" long) of 1 BID layups between the duct tape strips. This will thereby hold the L.E. in proper alignment after the duct tape and clamps have been removed.

NOTE: Recheck for a true vertical of the stab and proper alignment. Allow to cure fully.

22. Now add 2 BID along the entire L.E. joggle. Run these BID over the 1 BID pcs used in step 21, it will be easy to blend in the .010" ridge.

LANCAIR® 320FB

8-18

Chapter 8

REV.

0 / 11-1-91

VERTICAL STABILIZER AND RUDDER

23. Next add the 3 BID all the way up the T.E. channel formed by the vert stab skins and the vert stab spar (or stern post). See figure 8-9.
24. Add the 2 BID tapes to all joggles around the vert stab. Don't forget the short joggle along the fslg to stab line behind the H. stab.
25. Except for closing out the upper vert stab area where the rudder intersects, the vert stab is complete.

Closing the vertical stabilizer

Figure 8-9

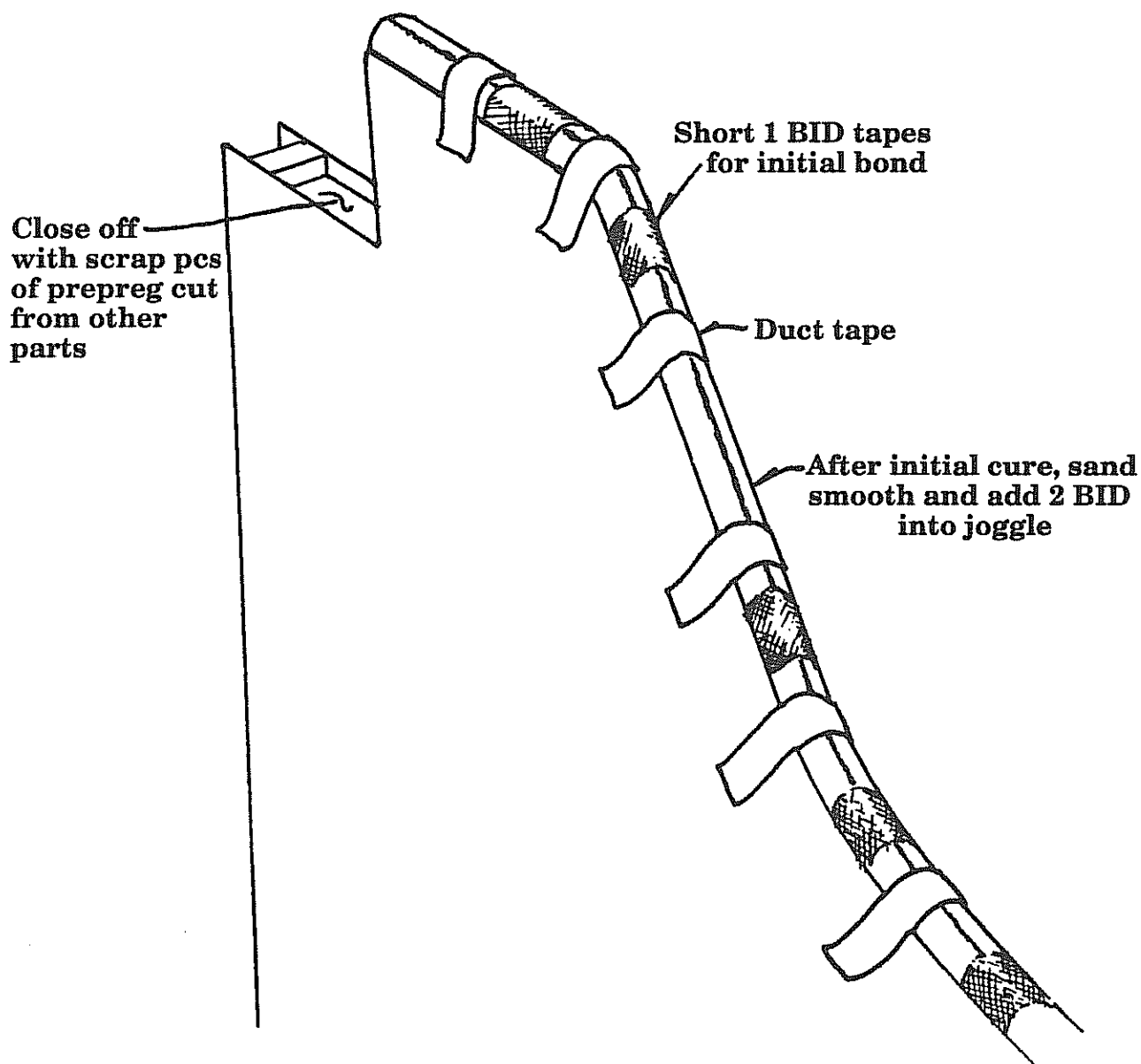

ELEVATOR TRAVEL LIMITS
27° UP TRAVEL, 13° DOWN TRAVEL
Figure 8-10

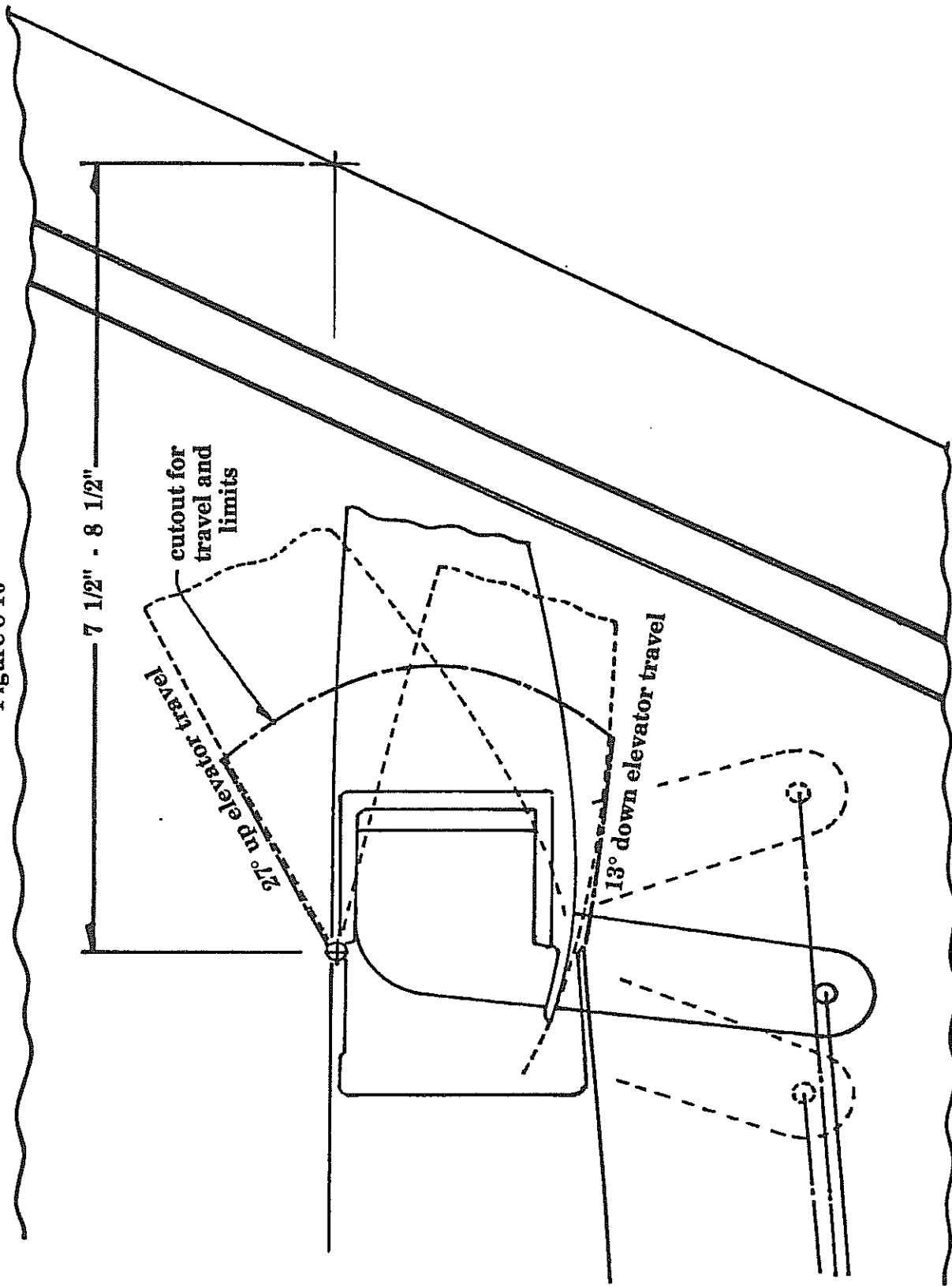

D. Rudder pivot assembly

Prior to setting the pivot pcs, the rudder must first be final fitted to the vertical stabilizer. This is fairly quick and easy to do.

1. Assuming that you have not yet made any cuts into the vertical stab to receive the fwd counter balance portion of the rudder, hold the rudder against the side of the vert stab and mark the lower trim line. Also mark the fwd trim line onto the vert stab. Set the base of the rudder to the best faired in position attainable and make any minor fairing adjustments to the top side with micro. The rudder will nest into the channel of the vert stab. Ideally, the rudder will be slightly wider than the vert stab to maintain attached airflow during flight.
2. The upper portion of the vert stab will require a closeout where it has been trimmed to accept the rudder counter balance. This final closeout and "fit" should be made after the pivot assembly is completed so that actual positions are finalized. At that time, micro is generally used to fill to a uniform clearance gap of about 1/16". Swing the rudder through full travel to check clearances.

Fairing in rudder

Figure 8-11

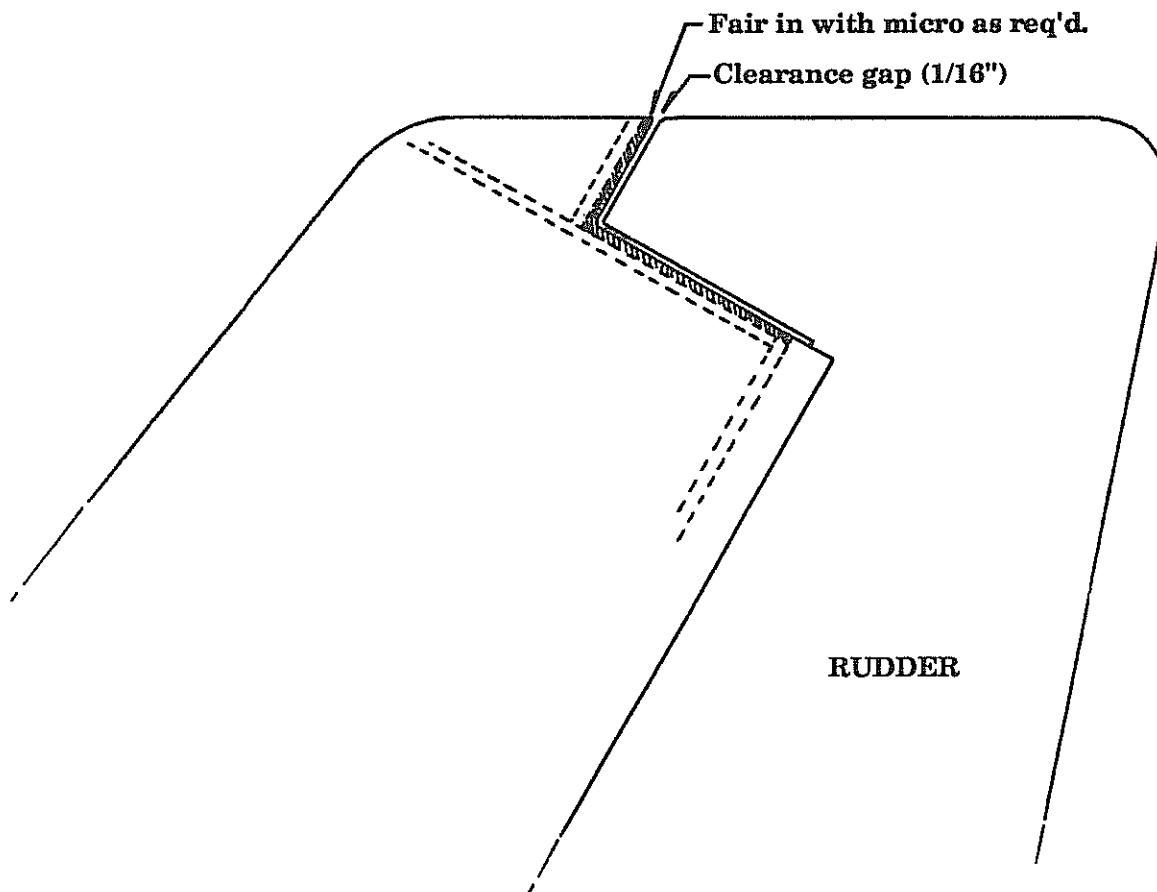

- E. Setting the pivot pieces into the vertical stabilizer**
1. Select the six rudder pivot pcs. The one with the "T" will fit to the lower rudder and receive the rudder cables. The ones with the 1/4" hole in the end will receive the AN4-12A bolt. This is a press fit, add a little epoxy or loctite during the press. You should first saw the bolt threads off, see figure 8-12.

The three remaining pieces will have the 5/16" holes and receive the small bushing (FB46-2) which are also press fit. These pieces will mount into the vertical fin with the shoulder of the bushing facing up.

Rudder pivot pieces
Figure 8-12

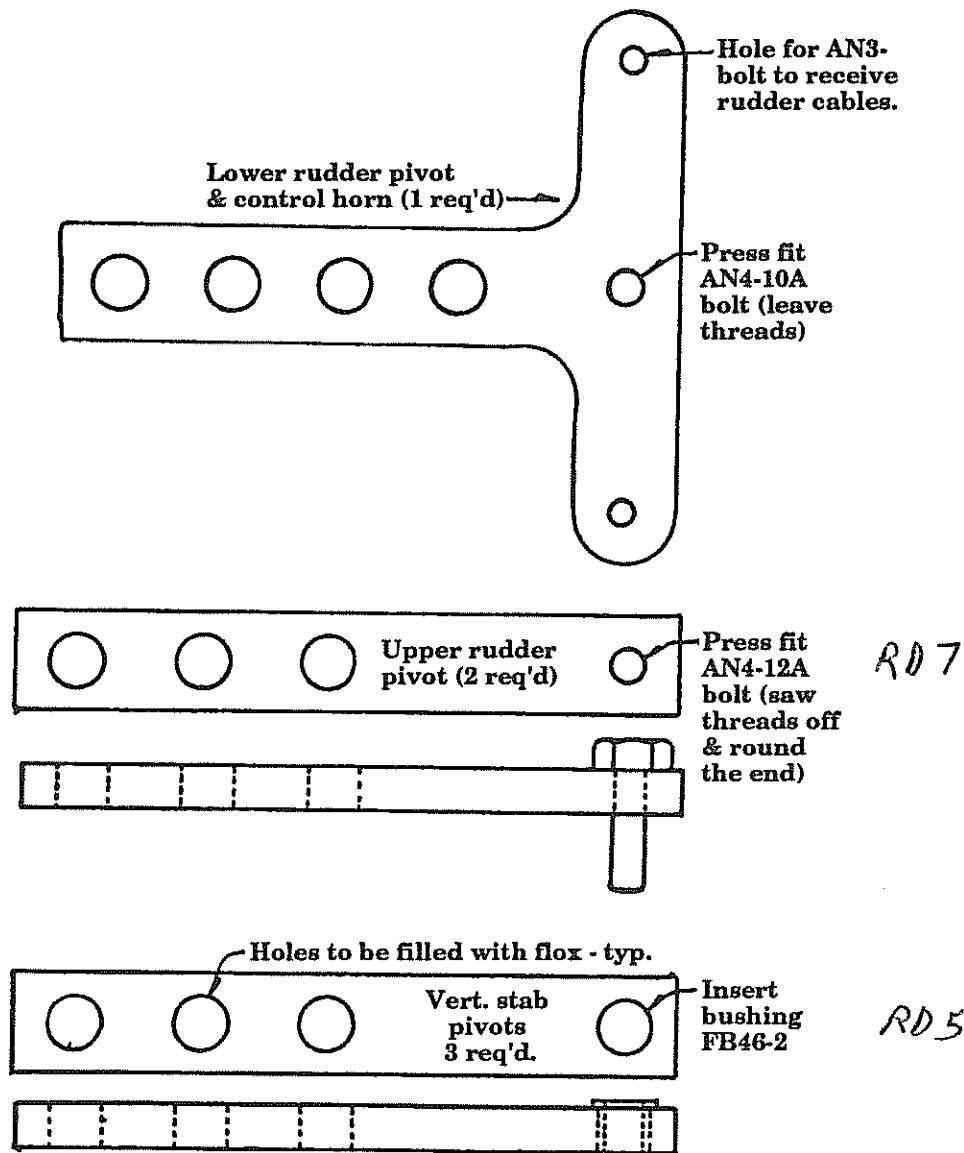

Typical rudder pivot assembly

Figure 8-13

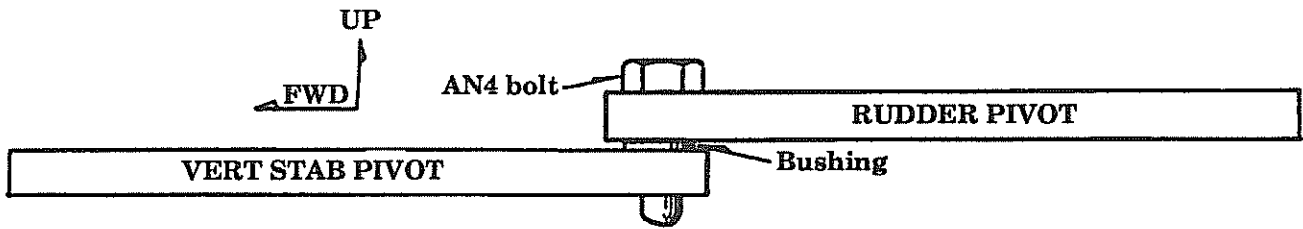

2. First locate the proper vertical positions of the vertical fin pivots on the side of the stab. This is why you marked the high density foam positions on the exterior of the vertical fin. These pivot pieces will be potted into the high density foam blocks. If you forgot to mark the block locations, place a bright light behind the fin. With room lights out it is just possible to see the locations through the skins.

The ideal position of the lower pivot assembly is per figure 8-4. You need not be exactly in the center of the high density foam block, any place within them will be sufficient.

3. Using a medium length drill bit (about 1/4"-3/8" dia. is o.k.), drill through the center (spanwise) of the vert stab spar and on onto the high density foam block. The drill bit can be moved side to side so as to enlarge the hole to accept the aluminum pivot shaft.

WARNING: Do not drill completely through the high density foam block.

The angle of the drill bit into the high density foam block must be such that the pivot shaft will fit perpendicular to the vert stab spar. This is required for pivot pin alignment between all three pivot centers.

The hole should be made a little larger than that of the aluminum pivot pcs. A loose fit is actually what you want. Epoxy/flox will be used during the final potting in process and this mixture should be fully around the aluminum pieces.

4. Drill for all three pivot pins. These pivot pins will be spanwise centered across the vertical stab spar and must be extended out beyond the aft face of the vert stab spar per figure 8-14. This distance aft is important for the proper alignment of the rudder L.E.

Rudder pivot pins

Figure 8-14

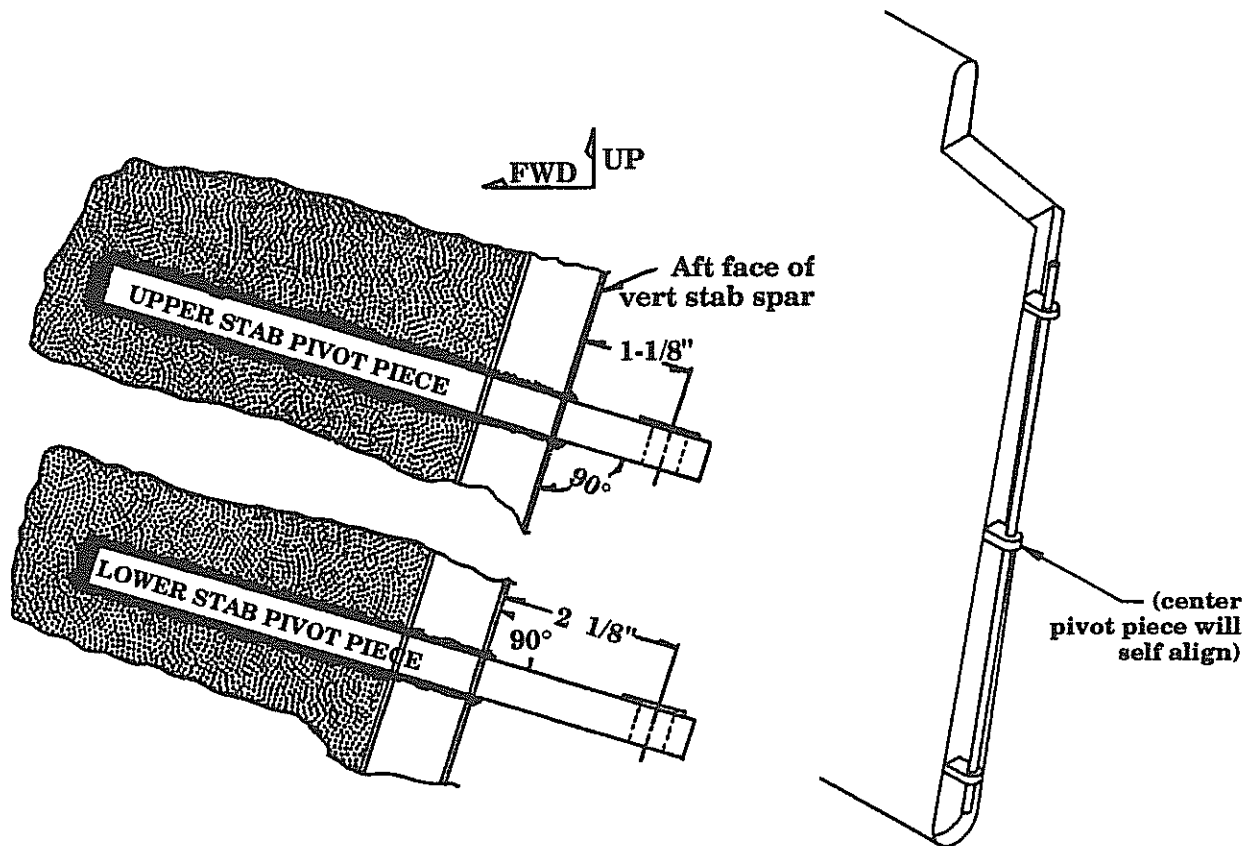

With the upper and lower pivot pieces potted in and centered left and right in the vert stab spar, run a long 1/4" rod through all three pivot bushings to assure concentricity of all pivot axes.

Use tape and wood shims to hold the pivot centers at the required distance aft of the vert stab spar web.

5. Obviously, all three pin centers must be concentric with each other for smooth rudder rotation. It is very easy to achieve this concentricity.

6. From your local hardware store, pick up some 1/4" steel rod. These pcs are usually stocked in 3' pcs which requires that you use two (the second pc can be cut down).

Also, from your Lancair kit, select a pc of the 3/8" x .083 aluminum tubing. This tubing is generally used for the outbd gear door hinge assembly but it works well to align the two pcs of 1/4" steel rod by sliding over them thus making a good alignment of the two.

If your gear doors are already assembled, there should be a short pc of the thick wall tubing remaining as scrap.

7. The 1/4" steel rod will slip through the three bronze bushings in the vert stab pivot pcs. See figure 8-14. Set the dimensions aft from the spar web at the top and bottom locations and the middle position will self align by virtue of the 1/4" steel rod. Use tape, and small shims (wood) to hold position when the final potting is performed.
8. Run a quick fit check with the full assembly of three pivot pcs and the 1/4" rod. The best method is to string the whole assembly onto the rod and then insert into the vert stab spar holes. Check that there is sufficient clearance room to nest all pcs into proper position. When it all fits in, remove and bond in permanently.

NOTE: The following can be done alone but you may wish to have an extra hand.

9. Mix up a good size batch of epoxy/flox, keep it a little on the wet side but not runny.
10. Pack the slots in the vert stab spar with this mixture. Use a mixing stick that is sanded down to a more narrow width - about the width of the slot so you can slip the mixing stick into the slot.
11. The slots must be well packed with epoxy/flox so that a good squeeze out of flox occurs when the pivot pcs are pushed in. Excess flox can simply be wiped away.
12. The aluminum pivot pcs should be lightly sanded and cleaned with acetone immediately before final assembly. Spread epoxy/flox into the large through holes of the pcs and get a good wet coat over the entire surface of the pcs that will be potted in.
13. With the slots now well packed with epoxy/flox and the aluminum pcs properly prepared (step 12), position and push all three pivot pcs into the slots thereby squeezing out excess flox. Scrape the excess off as it comes out to prevent it from dropping onto the lower assembly parts and making a big mess.

WARNING: YOU MUST GET A GOOD SQUEEZE OUT OF EPOXY/FLOX MIXTURE THUS ASSURING THAT THERE ARE NO AIR VOIDS ON THE CAVITY BEING FILLED AROUND THE HINGE PIECES. MAJOR AIR VOIDS COULD RESULT IN FAILURE OF HINGE RETENTION.

14. With the pcs not potted in, set the proper dimensions aft of the spar web. Also make sure that the whole assembly is spanwise centered. Secure position and allow to cure.

Spacing the lower pivot pc using shims

Figure 8-15

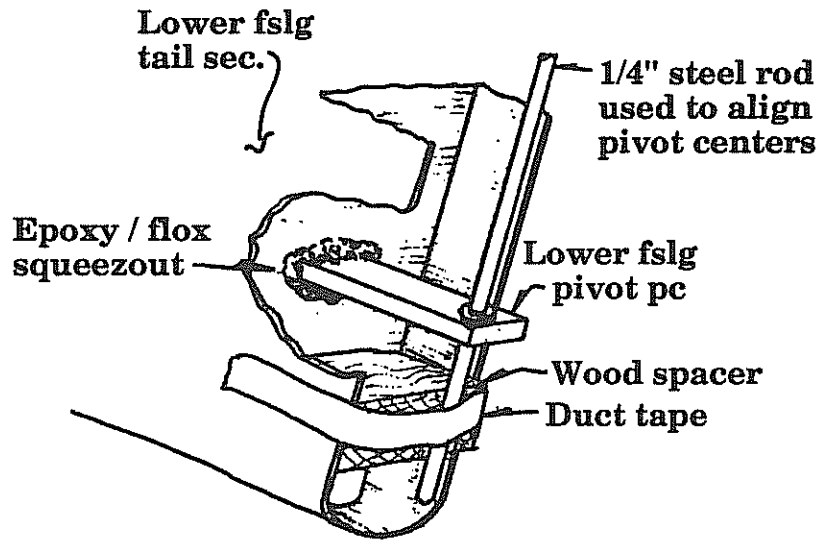

F. Setting the rudder pivot pieces into the rudder

With the vert stab pivot pcs now installed, the rudder pivot pcs can easily be fitted using the vert stab as an alignment jig.

1. Locate the correct position of the three pivot pcs by positioning the rudder and marking the relative locations for the pivots onto the skin of the rudder.
2. Note that the rudder pivots will install such as to be above the vert stab pivots by approximately 1/4" (It's actually 1/4" + the height of the bushing shoulder which is 3/64").
3. Mark the locations at rudder centerline where the pivot pcs will fit and in a similar manner is used on the vert stab, drill through the rudder L.E., through the rudder spar and into the high density foam blocks.

NOTE: The ideal location for the pivot pin centers is at the center of the front radius on the rudder. This radius dimension changes since the rudder is wider at the base than at the top thus the distance in from the L.E. will vary with each of the three pivot locations.

This is not extremely critical but if the locations of the hinge pin centers are off too much, the gap clearance between the vertical fin and rudder will change as the rudder rotates. However, pivot locations off as much as 1/8"-3/16" do not seem to cause much loss of fit.



Rudder pivot cross sections

Cross section at lower pivot location
Viewed from above looking down

Figure 8-16

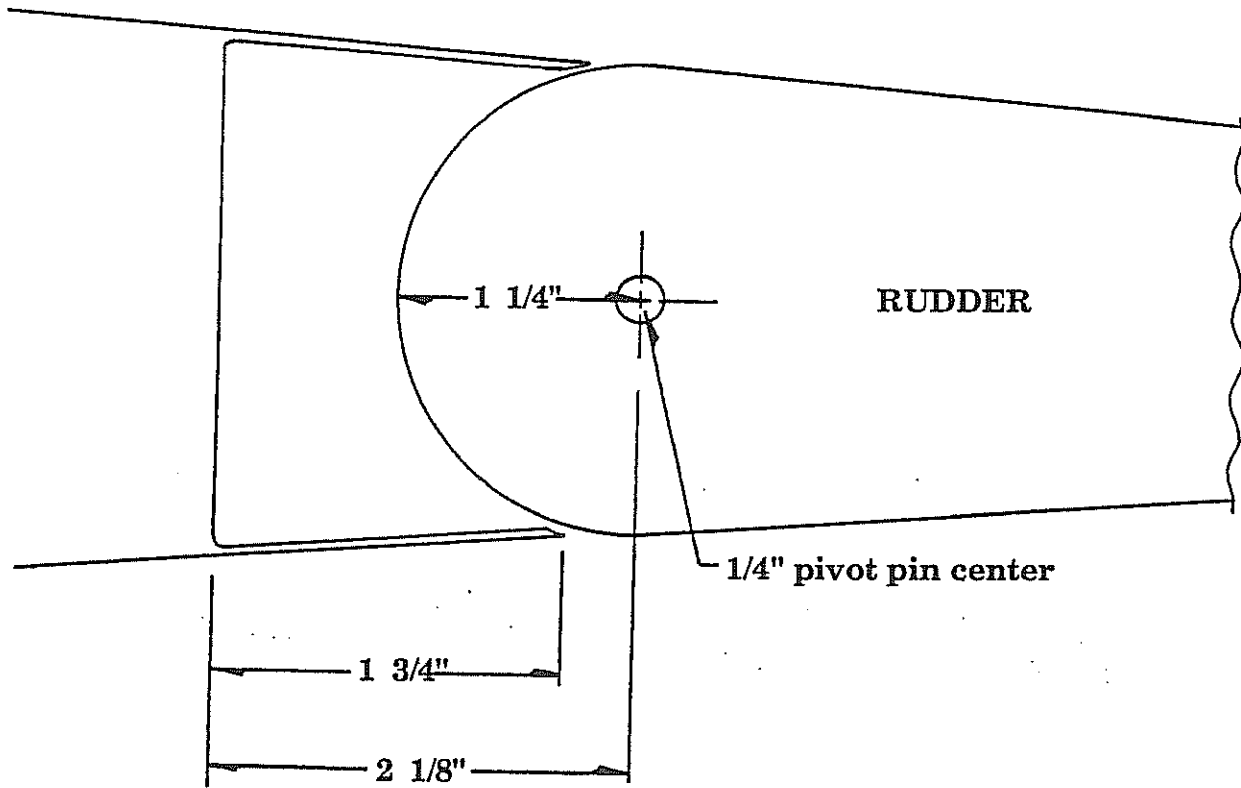

Cross section at upper pivot location

Viewed from above looking down

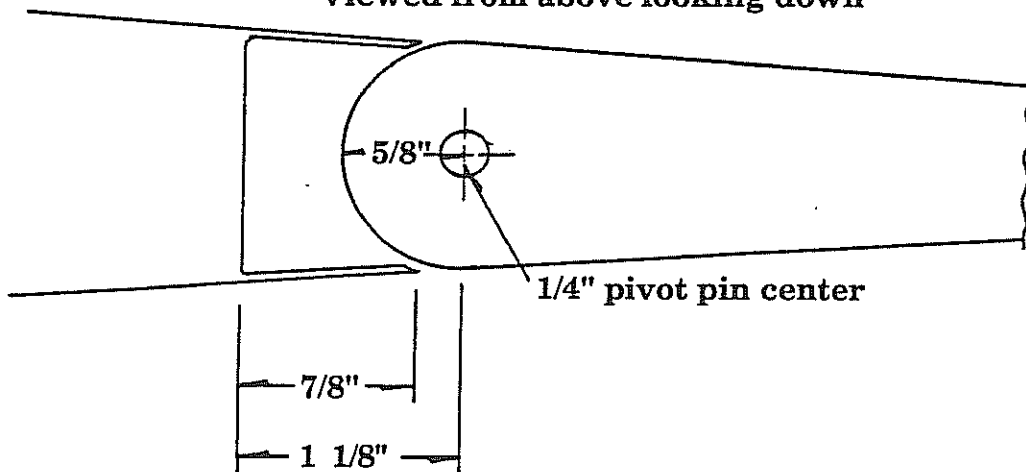



4. With the slots cut into the rudder, slip the rudder into position on the vert stab to check clearances once more. It's best to make one dry run with the rudder pivot pcs just to be sure. To do this, slip the three rudder pivots onto their respective positions. Slip the rudder onto the three extending pivot pcs and see that the rudder can be "nested" fwd into it's proper position.

5. The lower pivot pc with the control horn ears will require substantial clearancing into the rudder to achieve a fit. It will also require a slot into the vert stab to allow insertion and travel range. This slot must be sized carefully since it will provide the control limit stops. The final sizing can be done later so for now make the slots only large enough to allow the control horn to be installed with just a little lateral rotation permitted. Use a Dremel type rotary tool and flat file to notch into the vert stab and a rotary tool to cut into the rudder as required.

6. **IMPORTANT:** It is also very important that the rudder L.E. have vertical slots long and wide enough to allow the rudder to be removed after its' pivot pcs are cured in place. You must make certain that sufficient room exists to allow removal (upward) of the rudder. This requires that the 1/4" pivot pins in the rudder pcs can be lifted out of the vert stab. And that requires clearance in the rudder L.E. to allow the vert stab pcs to slide down far enough to allow the 1/4" pins in the rudder to be removed.

Check this a couple of times in a "dry run" condition until you're sure the rudder will be able to be raised up far enough to free the 1/4" pins. See figure 8-17 and 8-18.

7. These above slots in the rudder L.E. must also allow full, unrestricted movement of the rudder from left to right. That clearance however can be easily adjusted after cure and it is in fact best to wait until after cure to make this left/right travel adjustment.

8. The upper rudder pivot pc will generally require trimming down some what in order to fit into the rudder. The middle pivot, to a lesser degree, will require the same. Use a band saw or sabre saw to take only as much as required off in order to achieve the proper fit.



9. **NOTE:** An easy method of determining how far the rudder should be pushed into the vertical fin channel is as follows:

Standing to the side of the vertical fin, measure the distance from pivot centers to the T.E. of the fin (measured along a perpendicular line to the vertical stab). Now nest the rudder into approximate position and run a pencil along the edge of the vert fin T.E. thus placing a mark on the rudder at that point. When you remove the rudder you can then easily calculate the location of the pivot pin centers from the reference line you just placed on the side of the rudder. If it is close to the ideal location within the rudder then you'll know that rotation of the rudder will maintain a reasonably consistent gap clearance. If you're off a lot, then some slight adjustment fwd or aft with the rudder may be possible to improve the fit.

10. With the above fit checks made, you're about ready to bond the rudder pivots into permanent position. This is performed very similar to that on the vert stab with one additional fit check.

11. Fill the slots in the rudder with epoxy/flox and prep the aluminum pcs as you did with the vert stab aluminum pivot pcs.

12. In order to verify that you're going to get a good squeeze out of flox, you'll have to push the pcs into their respective slots with the rudder off so that you can view the squeeze out. Note the squeeze out and remove the pc once again. If the squeeze out was adequate, simply replace the same amount of flox into the slot and you're ready for the final bond knowing that the squeeze out is going to be sufficient (since you won't be too able to view it during the mating cure period). If squeeze out was insufficient, add more flox and recheck by again inserting the aluminum pc into the slot and noting a good consistent squeeze out.

13. When the correct amount of flox is attained, slip the aluminum pcs onto the vert stab such that they all face straight back. Now push the rudder into position, secure in place and allow to cure. If you place mixing sticks into the gap between vert stab and rudder, the gap will be established and nicely sized to about .050" clearance. Plenty of duct tape wrapped around the rudder to vert fin will hold it during cure. Be sure there is clearance at the bottom also.

NOTE: You should also be careful to not get too much flox packed into the receiving slots since too much could result in excess epoxy/flox filling in around the pivot points and effectively locking the rudder into place. This would then require a lot of careful grinding in order to release the rudder and damage could thus result as well.



Lower rudder pivot / control horn

Figure 8-17

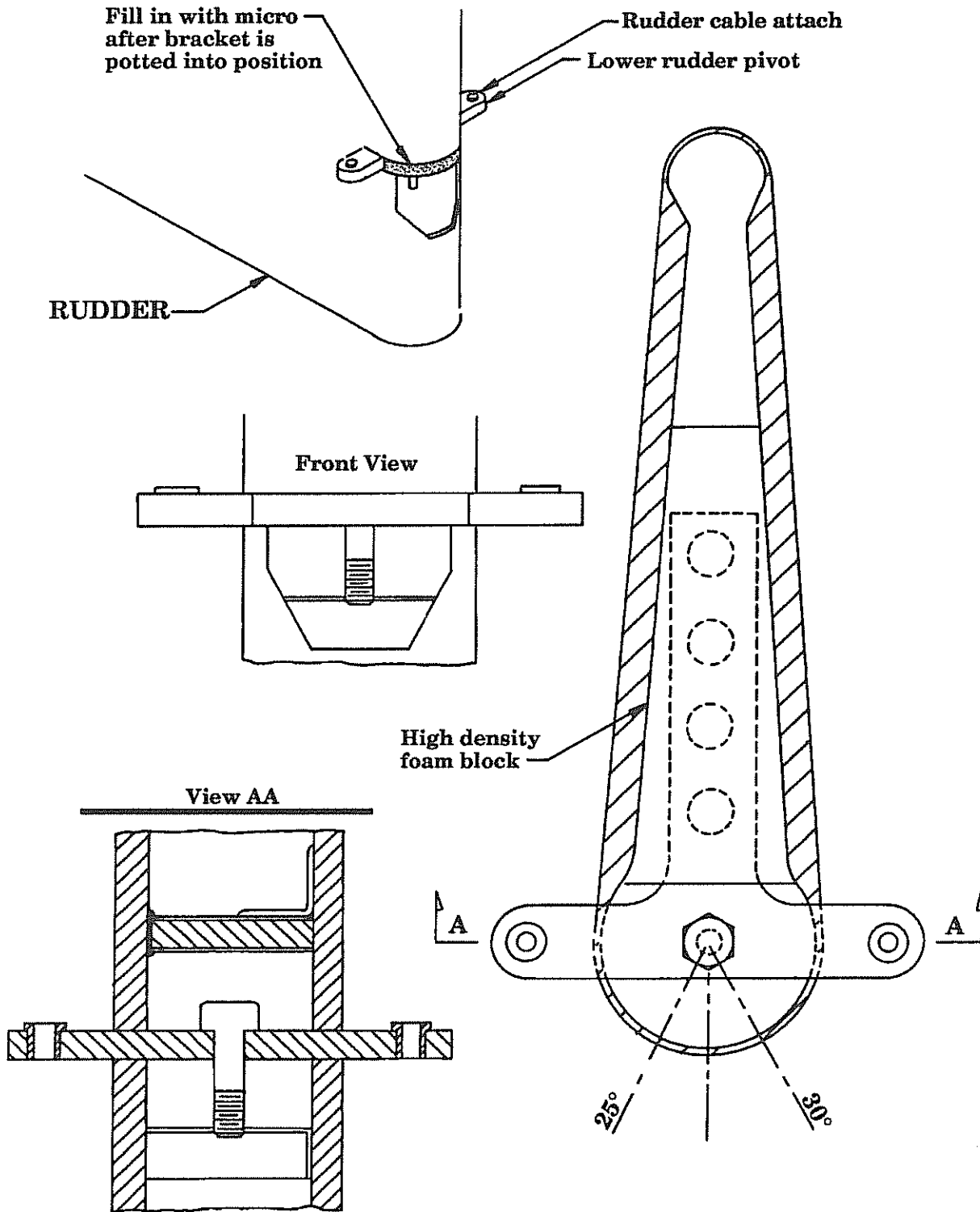

Upper rudder pivot

Figure 8-18

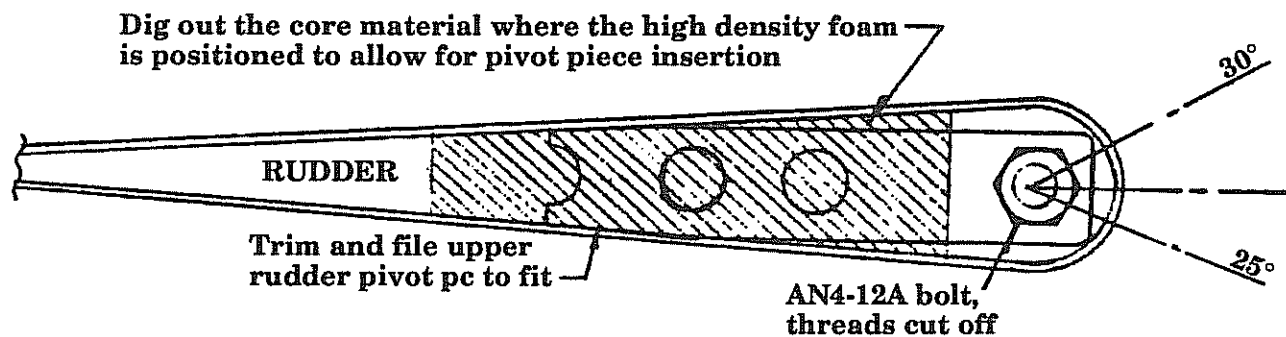

Rudder travel: 30° RIGHT, 25° LEFT

14. With the rudder now cured, remove it from the vert fin by gently rotating and pulling upward (remember now, you did make those slots deep enough - right?)
15. Check for adequate squeeze out of flox and remove any large amounts of excess with a rotary tool and 1/8" ball end cutter.

WARNING: BE CAREFUL NOT TO HIT THE ALUMINUM PCS WITH THE CUTTER. If it looks close, leave that glob of flox, don't risk hitting the aluminum with the cutter. **STRESS CRACKS COULD RESULT OVER TIME, RESULTING IN FAILURE OF THE HINGE PIECE.**

G. Rudder Travel Stops

Positive rudder control limit stops must be established. We use the fslg to form these stops. See figure 8-19.

1. This will be a back and forth fit check. With the rudder on, you'll note that the fslg (at the lower pivot/control horn assembly) will require slotting to allow full rudder travel. This slot must be carefully cut to allow maximum travel and nothing more. This will then generate the travel limit stops for the rudder. Use a rotary tool and/or small flat file to neatly cut the slots in each side of the fslg. Fslg contact at the stop must be across the full face of the rudder control horn. A flox pad can be added if necessary.

Establishing Rudder Travel

Figure 8-19

30° Right Rudder, 25° Left Rudder

To check and establish the rudder travel limits, find a section on the rudder where the chord is 9-1.2" and use it simply as a reference point (the top of the rudder just below the counterbalance section is adequate). At this point, standing behind the rudder, you'll have 30°s right rudder when you achieve a 5" dimension as shown below. 25°s left rudder will be established when you achieve a 4-1/8" dimension

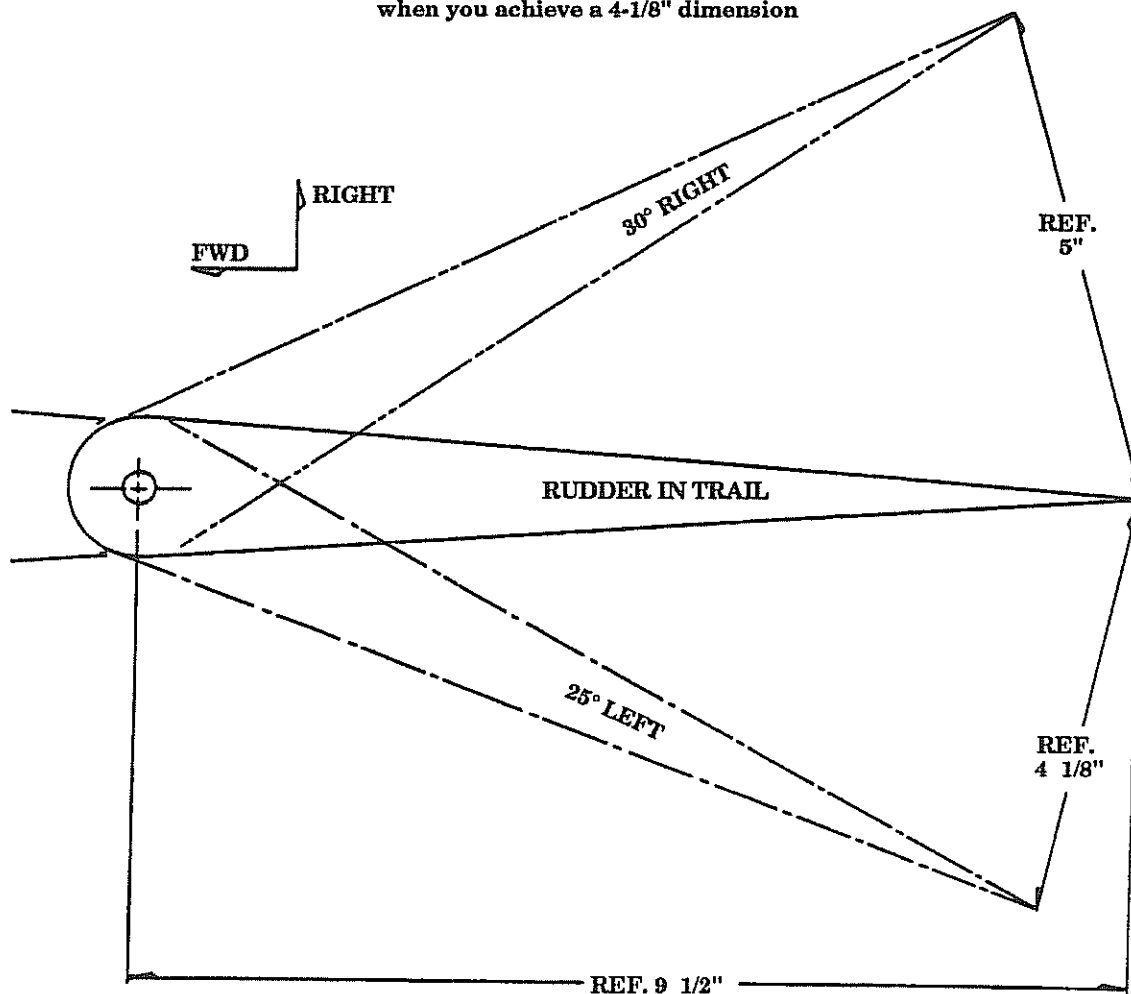

H. Securing Rudder

The lower rudder pivot bolt AN4) will also be used to permanently secure the rudder onto the vert fin.

1. Into the bottom of the rudder, cut a circular hole approximately 5/8" diameter. This hole must be located so as to align and be concentric with the pivot axis of the rudder.
2. Install the rudder onto the vert fin.
3. Form a piece of 3/8" x .085 x 5" aluminum tubing (thick wall 3/8" tubing), drill and tap a 1/4-28 threaded hole in one end. Use a #7 drill bit and 1/4-28 hand tap. Tap about 3/4" of threads into the tubing on one end.
4. Now insert the tubing and thread it onto the lower pivot bolt which has the threads remaining. It should be only snug, not torqued down.
5. With the tube threaded on, mark the line of the rudder bottom onto the tubing. Remove the tubing and cut it to the reference line thus making it flush when it is screwed back on.
6. Next make a slot across the tube end that is opposite to the threaded end. This slot should be sized to accept a standard screwdriver.
7. Next drill a hole through the same end, perpendicular to the slot, this will be for attaching safety wire. Use a 1/16" drill bit or about a #40. Also, drill a small hole into the rudder adjacent to the hole. Leave at least a 3/16" shoulder between it and the 5/8" access hole.
8. Now, simply snug up the threaded tube and safety wire it to the rudder thus locking the rudder in position. This safety wire check should be part of every preflight.

NOTE: Be sure that you can easily make a preflight check of the safety wire to insure its integrity.

Safety wiring rudder pivot bolt retention tube

Figure 8-20

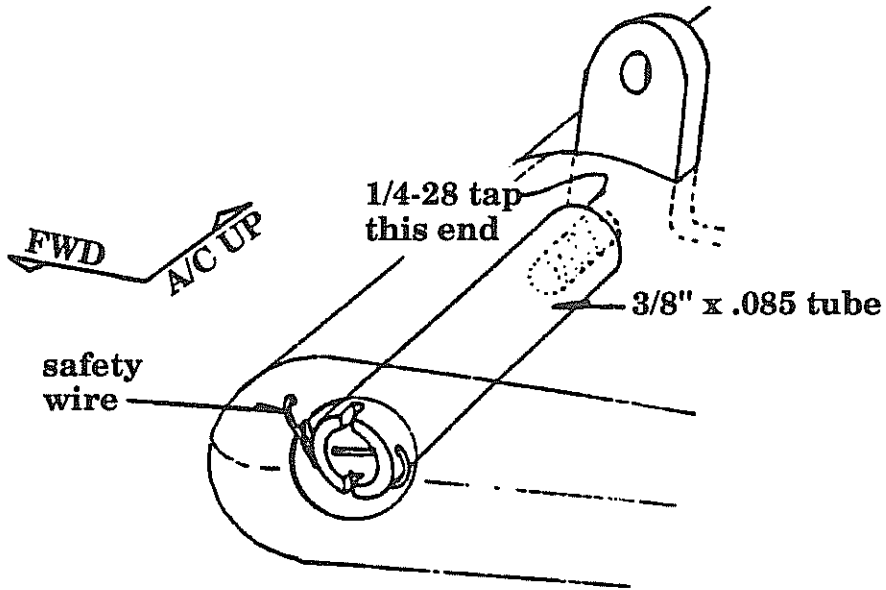

CHAPTER 9 REVISION LIST



The following list of revisions will allow you to update the Lancair 320/360 construction manual chapter listed above.

Under the "Action" column, "R&R" directs you to remove and replace the pages affect by the revision. "Add" directs you to insert the pages shown and "R" to remove the pages.

Page(s) affected	Current Rev.#	Action	Description
9-1 thru 9-8	0	None	Modified figure and text
9-9	6	R&R	
9-10 thru 9-58	0	None	



CHAPTER 9: OUTBOARD WING SECTIONS

REVISIONS

From time to time, revisions to this assembly manual may be deemed necessary. When such revisions are made, you should immediately replace all outdated pages with the revised pages. Discard the out dated pages. Note that on the lower right corner of each page is a "revision date". Initial printings will have the number "0" printed and the printing date. All subsequent revisions will have the revision number followed by the date of that revision. When such revisions are made, a "table of revisions" page will also be issued. This page (or pages) should be inserted in front of the opening page (this page) of each affected chapter. A new "table of revisions" page will accompany any revision made to a chapter.

Arrows

Most drawings will have arrows to show which direction the parts are facing, unless the drawing itself makes that very obvious. "A/C UP" refers to the direction that would be up if the part were installed in a plane sitting in the upright position. In most cases the part shown will be oriented in the same position as the part itself will be placed during that particular assembly step. However, time goes on and changes are made, so careful attention should be paid to the orientation arrows. That old cartoon of the guy agonizing over the plans for his canoe, built one end up, one end down, should not happen in real life. Especially to you.

CONTENTS

1. INTRODUCTION
2. DRAWING LIST
3. SPECIAL PARTS, TOOLS & SUPPLIES LIST
 - A. PARTS
 - B. TOOLS
 - C. MATERIALS & SUPPLIES
4. PROCEDURE
 - A. ATTACHING OUTBOARD WINGS TO FSLG
 - B. BL 105.5 RIB MODIFICATION
 - C. AILERON BELLCRANK ASSEMBLY
 - D. BL 50 RIB MODIFICATION
 - E. FUEL PICKUP LINE
 - F. FUEL TANK PICK UP LINE SCREEN FILTER
 - G. VENT LINE INSTALLATION
 - H. FUEL TANK BAFFLES
 - I. FUEL FILLER CAP INSTALLATION
 - J. AFT SPAR ATTACH BOLT COVERING
 - K. LOWER OUTBD WING SKIN INSTALLATION
 - L. WING TIE DOWN POINTS (OPTIONAL PIECES)
 - M. FUEL TANK SUMP DRAIN INSTALLATION
 - N. AILERON INSPECTION PANEL
 - O. FUEL TANK SEALER INSTALLATION
 - P. FINAL CLOSEOUT OF LOWER WING SKIN ASSEMBLY
 - Q. FLAP HINGE POSITIONS ON LOWER OUTBD WING SKIN
 - R. WING TIP INSTALLATION
 - S. WING TIP LIGHTING
 - T. TAIL LIGHT INSTALLATION
 - U. WIRING THE LIGHTING SYSTEM

LANCAIR® 320FB

9-1

Chapter 9

REV.

0 / 11-1-91

OUTBOARD WING SECTIONS

1. **INTRODUCTION**

This section will describe the final assembly of the Lancair wings. It will require the fslg to be securely positioned inverted and levelled both fwd and aft and left and right. If you have room, set up to build both outbd wing sections at the same time. This is not necessary, but will save time.

One important aspect to remember when completing your wings: it is obviously important to build them as accurately as possible, but to an even greater extent, it is most important to build the left one exactly like the right one (or vice-versa).



2. DRAWING LIST

Drawing	Page	Title
9-1	9-8	Leveling Wing & Fuselage
9-2	9-9	Outbd Wing
9-3	9-10	Tip Rib Placement
9-4	9-12	Outbd Aft Spar Attachment
9-5	9-13	Aileron Hinge Mounting
9-6	9-14	Outbd Aft Spar Hard Point
9-7	9-15	Typical Control Hinge Installation
9-8	9-17	Aileron Bellcrank Assembly
9-9	9-19	Aileron Bellcrank Attach Bracket
9-10	9-21	Aileron Bellcrank Installation
9-11	9-22	Aileron Bellcrank Assembly
9-12	9-23	Slotting the BL-74 Rib
9-13	9-28	Fuel Tank Pickup Line Installation
9-14	9-29	Vent Line Installation
9-15	9-31	Wing Fuel Tank
9-16	9-33	Fuel Filler Cap Installation
9-17	9-34	Fuel Tank / Aft Spar Bolt Cover
9-18	9-36	Trimming Ribs
9-19	9-38	Rib Caps
9-20	9-40	Wing Tie Down Installation
9-21	9-42	Fuel Tank Sump Drain Installation
9-22	9-43	Aileron Bellcrank Inspection Access Panel
9-23	9-48	Flap hinge installation
9-24	9-49	Wing tip installation
9-25	9-51	Type 2- wing tip lighting
9-26	9-53	Wing tip lens
9-27	9-54	Wing tip position lights
9-28	9-55	Wing tip strobe light
9-29	9-56	Wing tip light installation
9-30	9-57	Tail light installation

3. EQUIPMENT REQUIRED - SPECIAL PARTS, TOOLS & SUPPLIES

A. Parts

Fuselage as completed to this point

Left wing skin and spar assembly

Right wing skin and spar assembly



9-4

Chapter 9

REV. 0 / 11-1-91

OUTBOARD WING SECTIONS



B. Tools

- water level
- assorted wrenches
- metal shears (for trimming fiberglass - can use Dremel cutter or??)
- tape measure
- Dremel™ type rotary grinder
- drill motor
- drill bits:
 - 1/4"
 - #12
- vise with padded jaw
- 8' or 10' straight edge
- flaring tool
- hole saw, 2-1/2" diameter
- C-clamps (about 8)



C. Materials & supplies

- epoxy
- flox
- BID cloth
- micro
- 1/4" foam
- 1/2" foam
- 1" thick high density foam
- structural adhesive
- pop rivets (approx. 40)



9-6

Chapter 9

REV. 0 / 11-1-91

OUTBOARD WING SECTIONS





4. PROCEDURE

A. Outboard wing sections

This section will describe the final assembly of the Lancair wings. It will require the fslg to be securely positioned inverted and levelled both fwd and aft and left and right. If you have room, set up to build both outbd wing sections at the same time. This is not necessary, but will save you time and help make them more alike.

One important aspect to remember when completing your wings: it is obviously important to build them as accurately as possible, but to an even greater extent, it is most important to build the left one exactly like the right one (or vice-versa).

1. Secure the fslg on a bench in the inverted position, similar to that performed for the belly pan installation. You can use the BL 50 reference lines to level everything fore-aft & left-right.
2. Attach the outbd wings.
3. With a water level, check the level condition, measured at each wing tip L.E., and from wing tip to wing tip. If there's a difference, shim the fslg (at the longerons) to make the tips level with each other. At this point in the assembly, you're most concerned with the wings matching up and if the fslg is a shim thickness off, that's OK. What is now more important is setting up to establish identical outbd wing washout and that requires the above level condition be established regarding wing dihedral, as measured on the tip L.E.
4. Construct the wing tip rib fixture per blueprint "E" and figure 9-1. Make two of them if you are going to be working on both wings at the same time. The purpose of this fixture is to support and maintain the wing in the proper position while you perform the next few weeks of work, so build it accordingly. The wing tip rib pattern is drawn to exterior dimension, so you can use it to trace the pattern onto the fixture.
5. Place the fixture in position under the wing(s), and adjust it so that it is supporting the wing, and everything is still level.
6. Secure the fixture to the floor, using Bondo or similar, so that it will not slide or move if bumped over the next several days of work.
7. The outboard upper wing skins may have to be trimmed down to align at BL 50 This will require a back and forth fit and trim. To allow for flexing, a 3/32" gap must be maintained all around the BL 50 butt line. Take care to establish this as a smooth, straight butt line with that 3/32" gap.



8. Make sure everything is still level, and that the top skins are meeting properly. When you are satisfied that all is correct, hold the aft spar plate in place (see fig. 9-4) and note that it will require a very slight bend to align properly with the inbd and outbd sections.

LEVELING WING & FUSELAGE

Figure 9-1

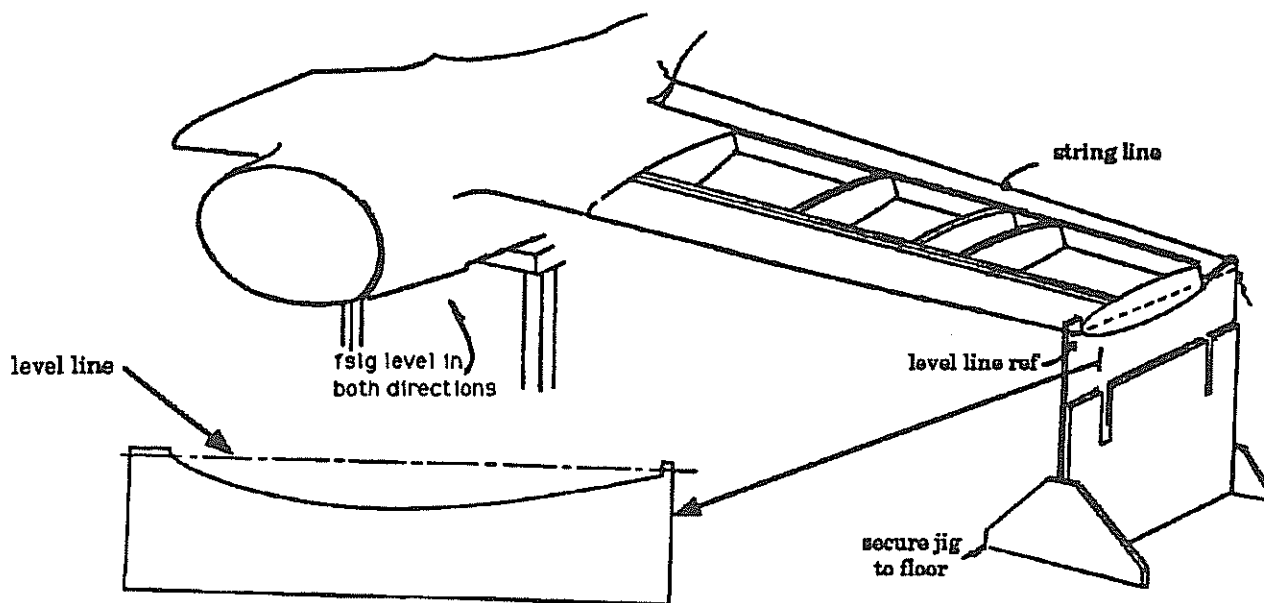

9. Using a vise with the jaws padded so that you won't gouge or scratch the surface, bend the spar bar slightly to match the angle of the aft spars. If you get any scratches or gouges, file them smooth and finish with 220-320 grit sandpaper.
10. Drill and attach the aft spar attach plate to the inbd section by drilling two 1/4" holes through it. Be sure to check for clearance from gear strut. Be sure that your bolts locate fully in the aluminum block that is in the ctr aft spar. This block is 5" long, see figure 9-4.

OUTBOARD WING

FIGURE 9-2

VIEWED FROM BOTTOM, SHOWING UPPER WING SKIN IN POSITION WITH UPPER WING SKIN AILERON AND FLAP DIMENSIONS

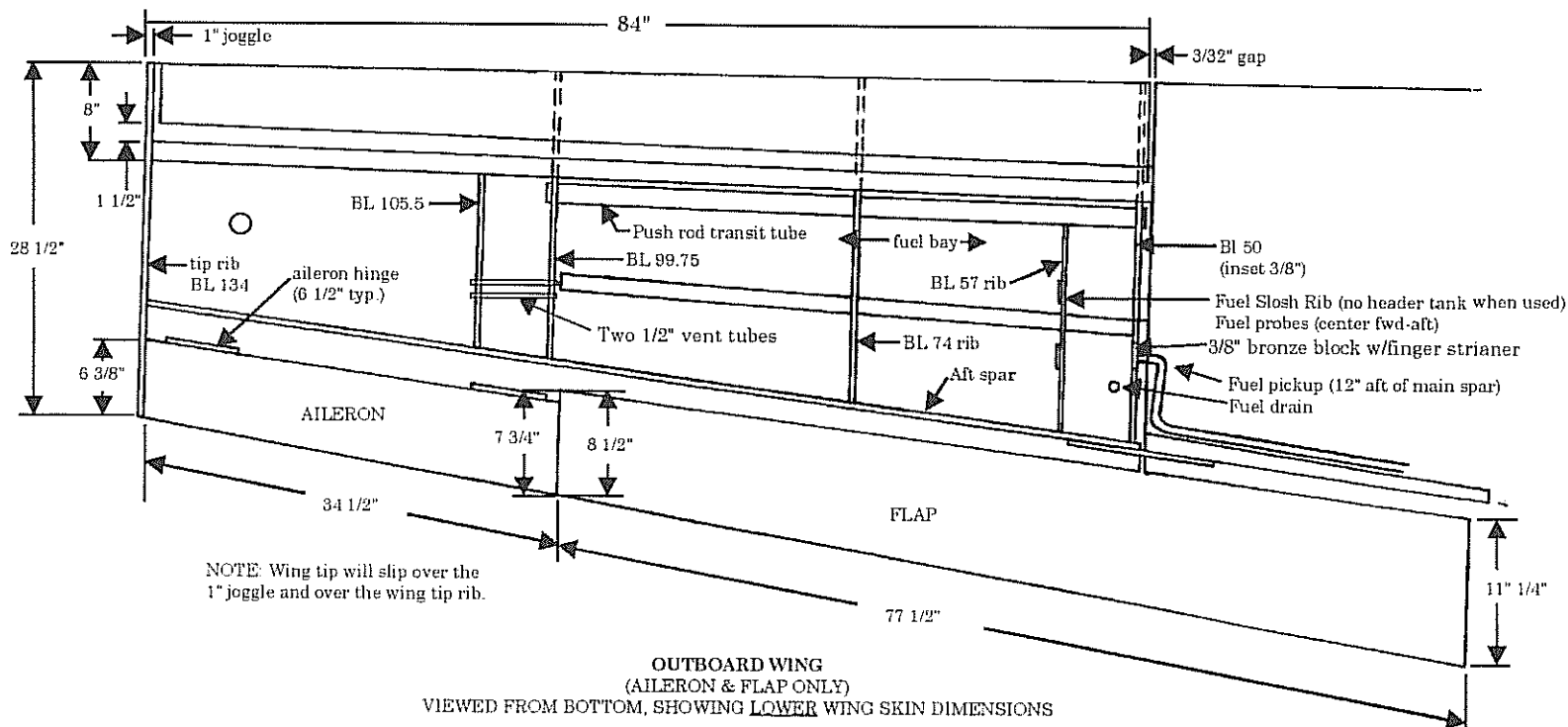

OUTBOARD WING
(AILERON & FLAP ONLY)
VIEWED FROM BOTTOM, SHOWING LOWER WING SKIN DIMENSIONS

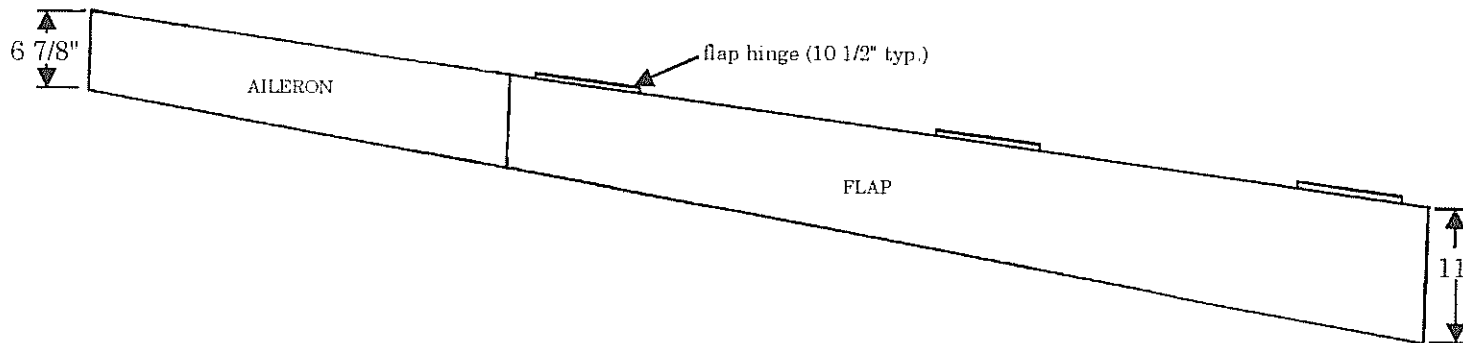

WING DIMENSION ALLOWABLES:

Wingspan: $\pm 1"$

Span variations from left to right are actually quite forgiving, but, excess variation could produce a rolling moment. A dimension measured from center line to the wing tip (at the main spar location) is very easy to establish to within $\pm 3/8"$ or so. When measuring along the trailing edge of the wing, dimensional variations can swing a little wider due to wing tip rib angle. This is more tolerable of variation.

Measure from the outbd edge of the aileron to the inbd edge of the flap. This dimension should be $\pm 1"$. Any variations can be split dimensionally between the aileron and flap however the aileron should not be made less than $34-1/2"$ long as shown in figure 9-2.

Setting wing tip / aileron buttline position

See figure 9-3. Adjustment is very easy since the tip rib can essentially "float" inbd or outbd under the wing skins and thus it's location does not have to define the outbd edge of the aileron. The angle of the tip rib to the main spar is not critical thus the trailing edge of the tip rib may be inbd or outbd without adversely affecting the wing layout.

The outbd edge of the aileron is shown in figure 9-2 as being against the tip rib, **THIS IS NOT REQUIRED**. The tip rib may actually be outbd of the aileron edge and thus the wing tip panels (upper and lower) would simply extend over the rib to define the edge of the aileron. This could actually have a positive effect by providing an accessible joint surface onto which a 1 BID tape could be applied.

You will also note that the tip rib is generally positioned at a slight angle beyond "square" to the main spar, (off perpendicular by $3-4^\circ$'s), this is normal.

Tip rib placement

Figure 9-3

Example: If the wing tip rib were to be skewed outward at the trailing edge, the fit could still be easily made since the wing tips establish the aileron edge

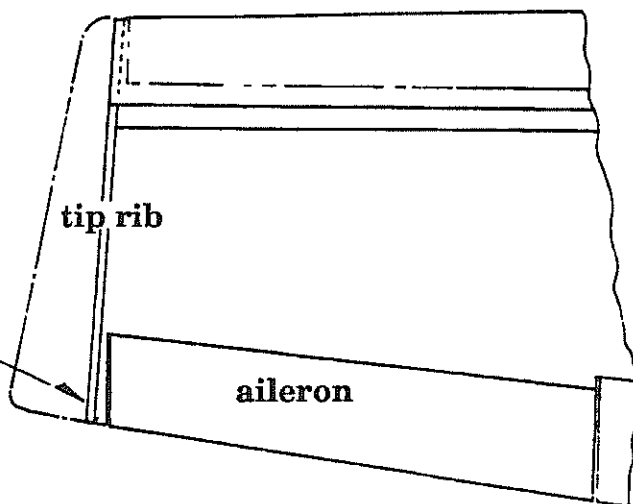

Additional wing tolerances:

See figure 9-2:

- Wing tip chord: $\pm 1/4$ ".
- Total dimension of aileron and flaps along T.E. 112" - 113".
- Aileron span: 34.5" minimum
- Aileron chord: +0", -5/16" (the +0" is because adequate clearances must be provided for aileron counterbalance weights and flap rolled L.E.'s.)
- Rib BL stations: BL 74 rib: ± 1 "
BL 99.5 rib: +1/2", -1" (+ equates to farther outbd)
BL 105.5 rib: +1", -0".



11. Mark out and drill for the two outbd 1/4" attach bolts. Note that these bolts must be far enough outbd to clear the rib near BL 50 and give you enough room for the bolt head (or nut) and still be placed inside the area of the phenolic hard point (refer to figure 9-4).

The preferred method is with the bolt placed such that they enter from the aft with nuts fwd. Thus, if ever necessary, you'll be able to remove them without puncturing the fuel tank. See figure 9-17 for nut cover plate recommendation in fuel tank area.

OUTBD AFT SPAR ATTACHMENT
FIGURE 9-4

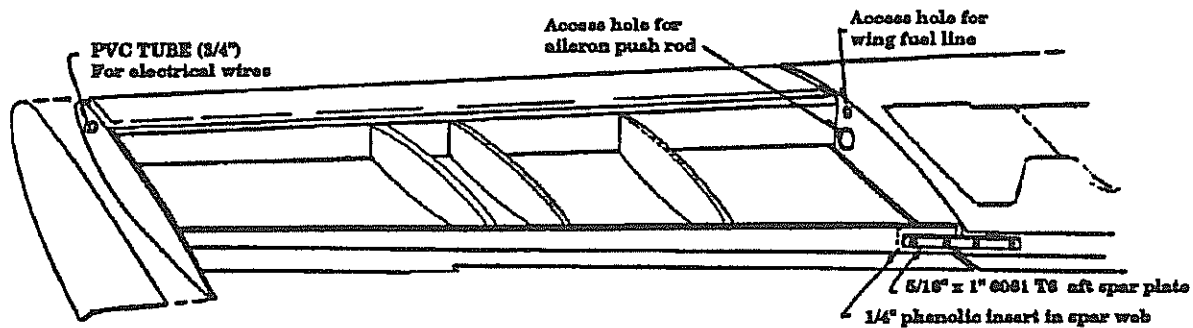

OUTBD AFT SPAR ATTACHMENT
MID-WEB, CUT-THROUGH VIEW, LOOKING DOWN ON LEFT WING

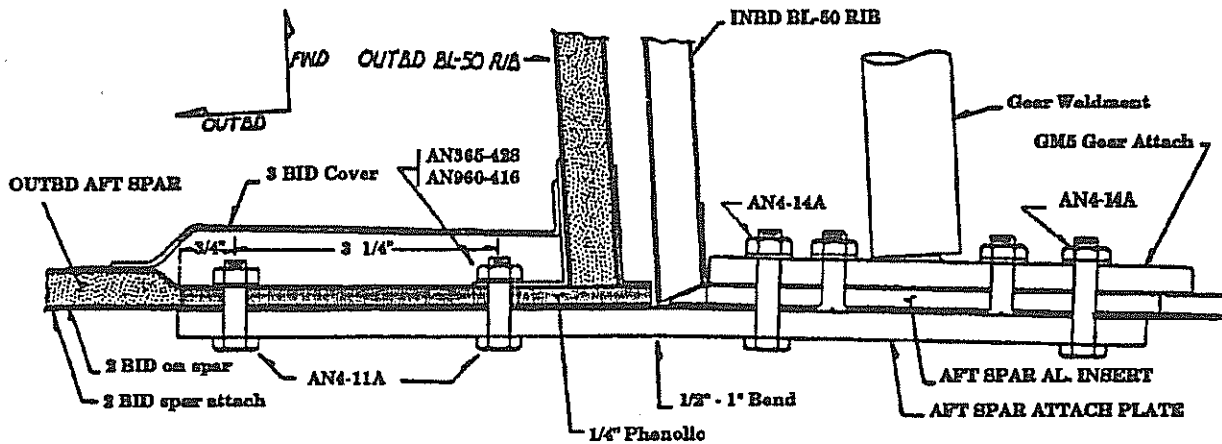

12. Per figure 9-2, mark out the trim lines on the upper wing skin for the aileron and flap. The line for the aileron will be a hinge line, the line for the flap will not since the flap hinges from the bottom skin. The flap line can be adjusted as the flap is installed. The aileron hinge line should be set accurately at this time.

There are already 2 BID applied to the full span between aft spar web and upper skin.

Note: Before starting this layup, have a straight edge handy long enough to go from the fslg to the wing tip.

13. At the locations of the two aileron hinge sections, six (6) additional BID must be applied (making a total layup of 8 BID at these locations - 2 are already done for you). These additional 6 BID must also run from skin T.E. fwd and lap onto the spar web to at least 50% of the web height (see figure 9-5). At these aileron hinge locations, the skin must be notched to nest the hinge pin sections and generate a narrow gap between aileron and wing skin, see figure 9-7. This notch should be done after all BID have been applied and have fully cured. With the trim line marked (using the string at wing T.E. as a measuring reference), trim and add the 6 BID at the aileron positions.
14. Place plastic over the wet BID (it is also a tidy idea to use peel-ply over the wet BID before adding the plastic). Now clamp the skin T.E.'s all the way from fslg to tip. You will be clamping onto the wet BID (that's why the plastic is used). This should give you a nice straight surface later for your hinges, and look good, too. Use care not to rub or shift the wet BID when clamping on the straight edges. Allow to cure.

AILERON HINGE MOUNTING

Figure 9-5

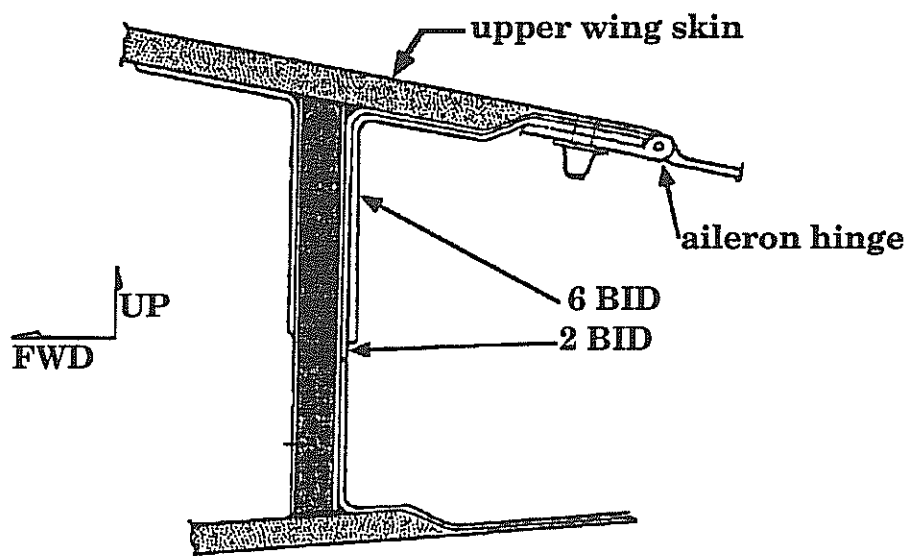

15. After cure, remove the clamps, plastic and peel-ply. Trim the layup bid to the previous trim lines. Use a heat gun to facilitate the trimming.
16. Cut the notches for the aileron hinges. See figure 9-7 for the best notch to fit the hinge sections. If this is done carefully, a very small gap between aileron and skin will result which is not only aerodynamically good but also looks good.

OUTBOARD AFT SPAR HARD POINT

Figure 9-6

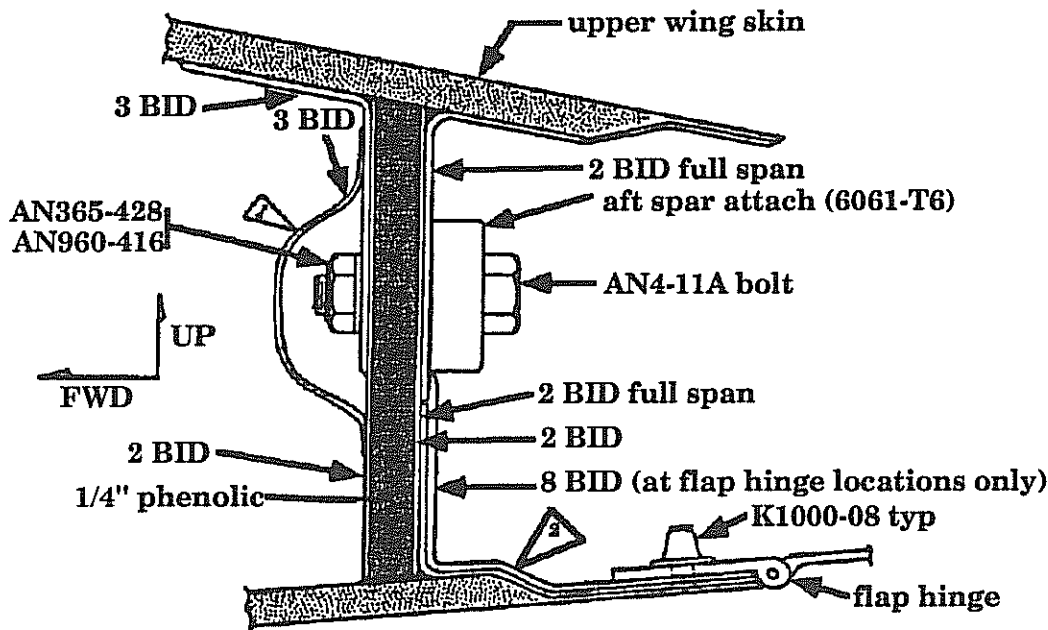

- 1 This 3 BID layup is to form a small cover over the two aft spar attach bolts. These bolts will extend into the fuel bay and must be sealed off to prevent fuel leakage. Extend this cover inward to the BL 50 rib. If removal is ever required, a small hole can then be made through the BL 50 rib to access these nuts without cutting into the fuel tank.
- 2 When locating hinge section positions on the wing skin, verify that the hinge section will sit FLAT on the skin (i.e., the skin core material must end before the hinge plate starts). If the hinge plate were to ride up onto the core, then the hinge plate would not be flat to the skin line and would be unacceptable. If core material does project into the hinge section positions, cut it back and close out the area with 2 BID.

TYPICAL CONTROL HINGE INSTALLATION

Figure 9-7

Elevator sections.....6.5" per section,	2 sections per side,	4 total required
Aileron sections.....6.5" per section,	2 sections per side,	4 total required
Flap sections.....10.5" per section,	3 sections perside,	6 total required

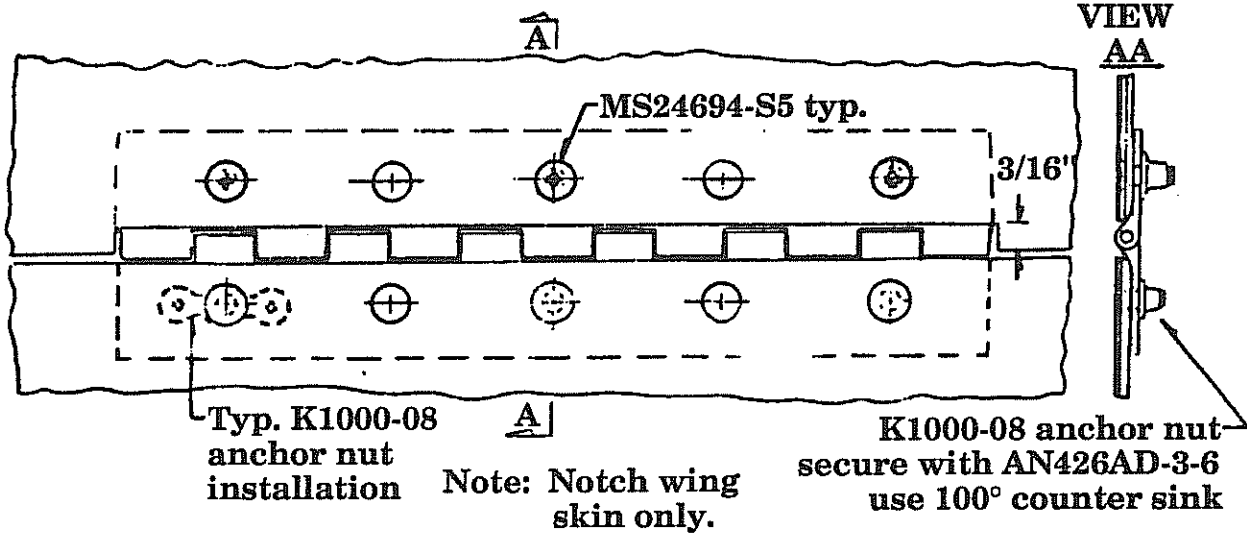

B. BL 105.5 Rib Modification

1. A phenolic hard point must be inserted which will provide the attachment for the aileron bellcrank brackets. See figure 9-8. Remove the 2 BID covering the core on the outboard side of the rib. The phenolic must be inserted from the outbd face of the rib to provide a flat surface on the inbd face for the bellcrank brackets to mate.
2. Remove the core material from the area where the phenolic hard point will be inserted.
3. Prepare the remaining inbd 2 bid by sanding, removing all core material.
4. Using epoxy with 50/50 micro-flox, bond the phenolic hard point into place.
5. Cover the outboard side with 2 BID.



AILERON BELLCRANK ASSEMBLY

Figure 9-8

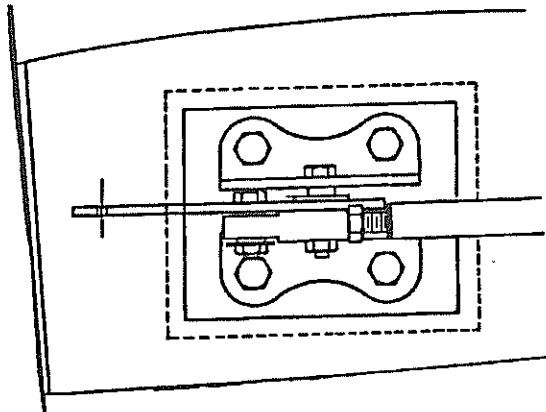
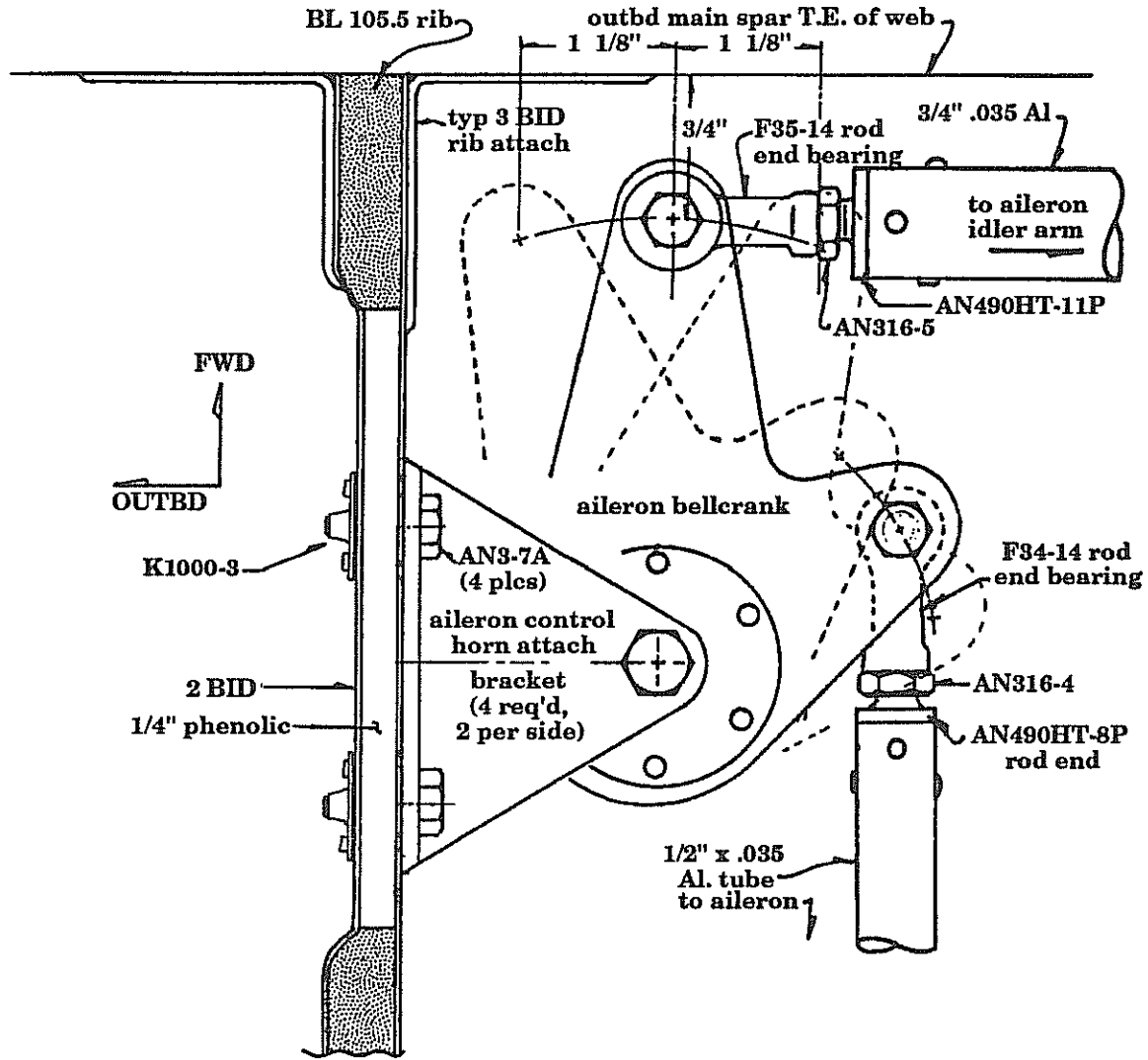

C. Aileron Bellcrank Assembly

The aileron bellcranks will attach to the BL 105.5 rib, onto the hard points you installed earlier.

1. Material for these bellcranks is supplied. It is a piece of .125" aluminum with two 3/4" holes already punched into it which will accept the BC4 bearings. The outline of the bellcranks are also indicated along with the to #12 holes which must be drilled to attach the push rods.
2. Trim the pieces to shape. The shape is not particularly critical, just be sure to use a file to get a smooth final edge with no saw cuts or nicks remaining.
3. It is a good idea to clamp the two bellcranks together when the two #12 holes are drilled. This will assure that the hole centers are the same distance from the rotational center of the bearing position.
4. Attach the BC4 bellcrank bearings using a minimum of six (6) AN470AD-4-6 rivets. Be sure that the bearings sit flat on the surface of the bellcrank. The bearing should be mounted such that it is on the bottom when installed.
5. Next cut out four (4) bellcrank attachment brackets. They are cut from standard pieces in the kit - 1" x 2" x .125" angle aluminum. See figure 9-9.



AILERON BELLCRANK ATTACH BRACKET

Figure 9-9

4 required, all identical.
Make from 1" x 2" x .125"
angle, 6061-T6

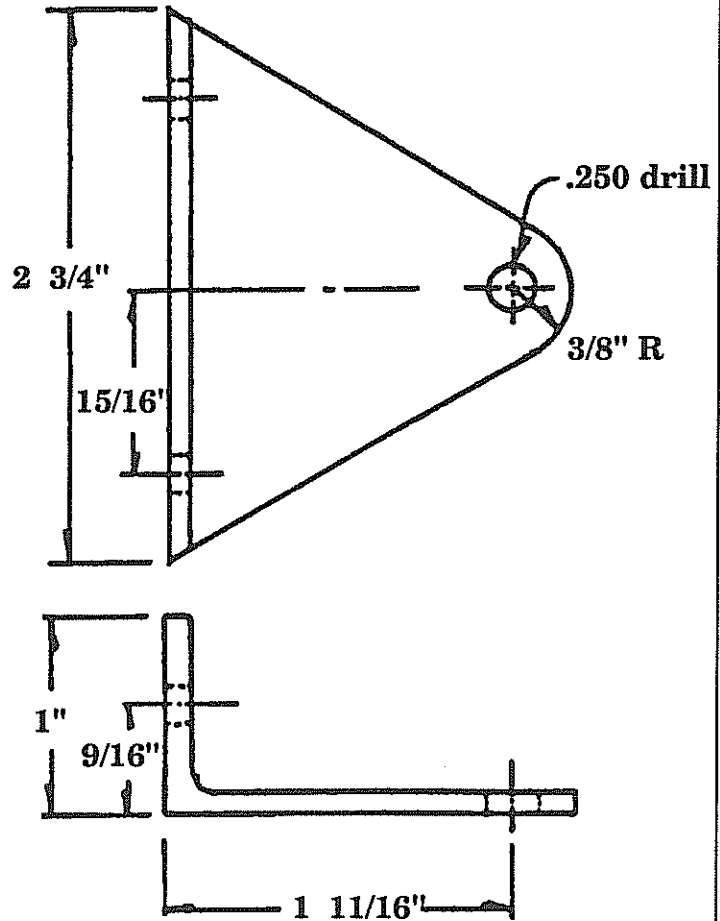
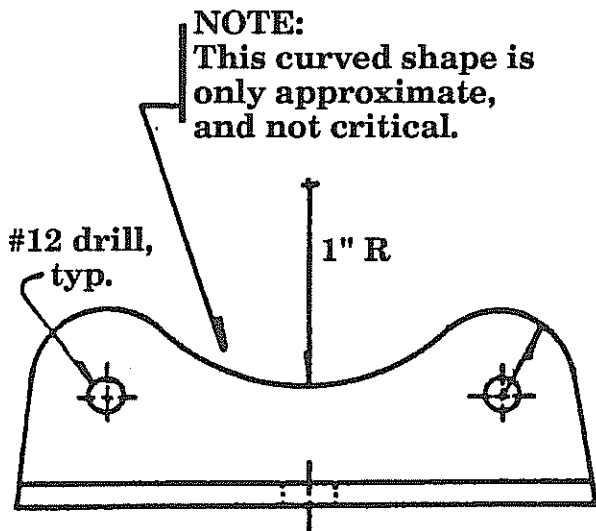

6. Assemble bellcrank with upper and lower attach bracket using the AN4-12A bolt. This should be bolted up tight with the AN365-428 stop nut.

The aileron push rod must transit through the fuel tank area. To do so, your kit is supplied with a thin wall aluminum tube of 1-3/4" diameter. This tube will be installed so as to provide an access through the wing fuel tanks for the aileron push rod. The tube installation must be accurately located to allow full travel of the push rod **WITHOUT ANY INTERFERENCE**.

7. Clamp the aileron bellcrank assembly into position using one or two C-clamps over the BL 105.5 rib section, referring to figure 9-8 and 9-10. The bellcrank should fit about 3/4" aft of the main spar web and vertically at the mid-chord height location.

8. Run the string line from aileron bellcrank to aileron idler arm in the stub wing. This will simulate the aileron push rod center line. This will also require cutting some small holes in the intervening ribs. The push rod's span wise travel is 1-1/8" each way from center, or 2-1/4" overall. Most of the travel of the push rod will be in the inbd-outbd direction but there is some travel in the fwd-aft direction due to the rotation of the outbd bellcrank, and some vertical movement at the inbd end due to rotation of the idler arm in stub wing attachment.

NOTE: When you go to install the tube, you will either have to remove the wing or, what is probably easier, cut a slot in the BL 74 rib down to where the tube will mount, so that you can put the tube through the slot (refer to figure 9-12). Then you can get it into the hole you need in the BL 99.5 rib, and then back into the hole you need in the BL 50 rib. If this is your choice, then you will later have to fill in the slot and replace the 2 BID per side on the rib.

NOTE ALSO: You can also connect the actual aileron push rod instead of using the string. The push rod should be mounted to the top side of the bellcrank so its bearing will (when the aircraft is upright) lay on the bellcrank rather than hang below it (refer to figure 9-11). Again, it might be easier to do this with the slotted BL-74 rib.

Note that the bellcrank assembly is mounted at about a 3° angle on the rib (see figure 9-8). This is to eliminate any interference as it moves through its arc. Be sure before you mount it permanently that you can swing it throughout its entire range of travel without any interference. It can be mounted underneath the bellcrank if necessary, but on top is the method of choice.



AILERON BELLCRANK INSTALLATION

Figure 9-10

Mark the positions of the rib sections. Measure the distance fwd/aft and vertically to the string line indicator. This will provide a good means of determining the position of the transit tube center. If additional clearance is required for push rod operation, the bellcrank itself can be shifted slightly to accommodate.

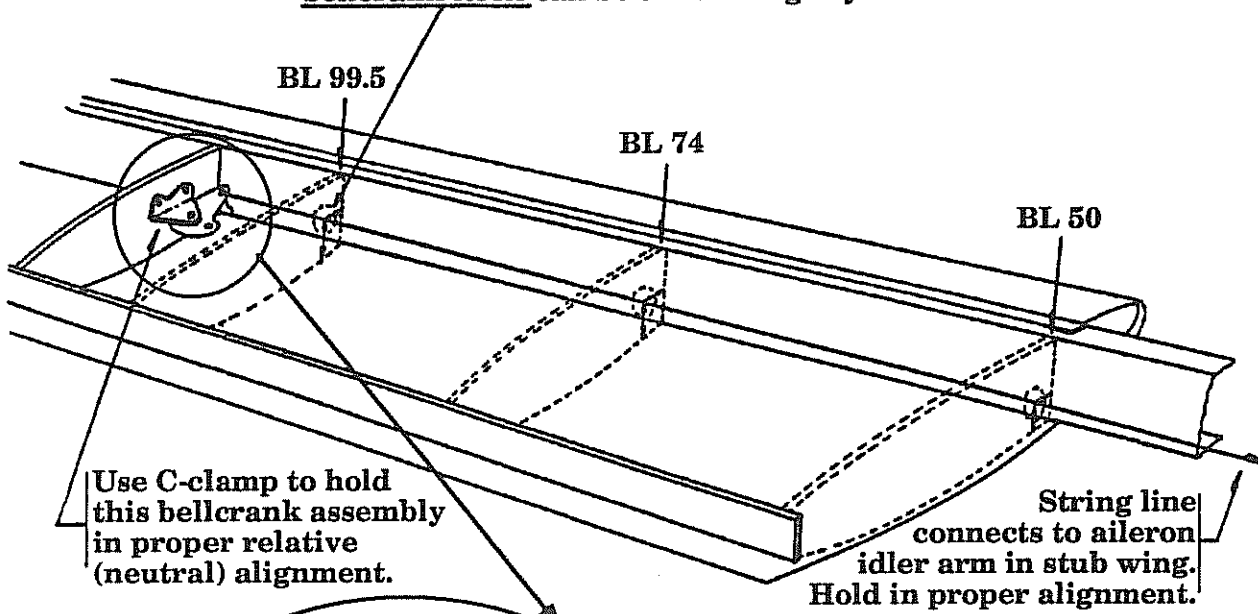

Use C-clamp to hold this bellcrank assembly in proper relative (neutral) alignment.

String line connects to aileron idler arm in stub wing. Hold in proper alignment.

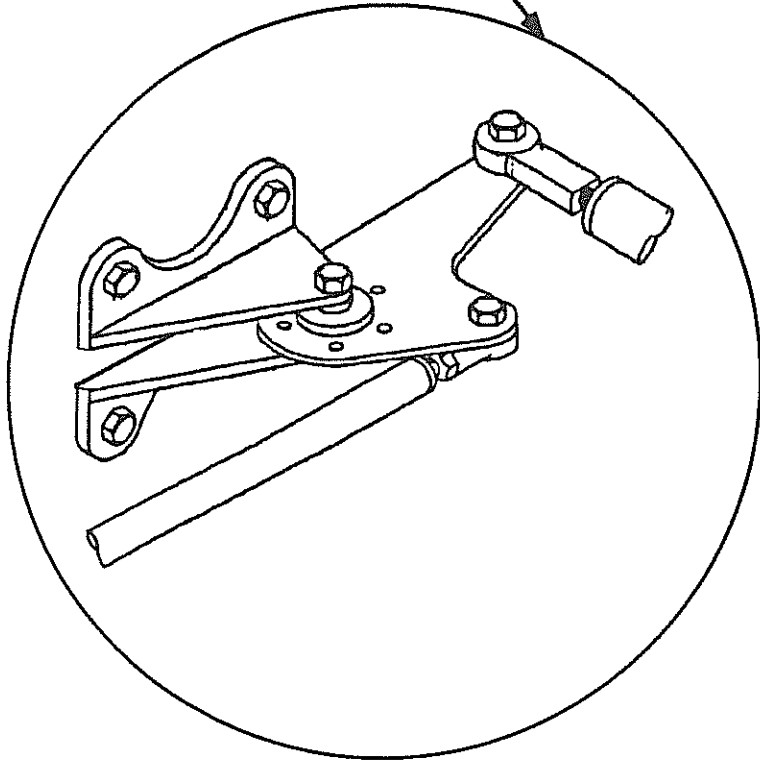

AILERON BELLCRANK ASSEMBLY

Figure 9-11

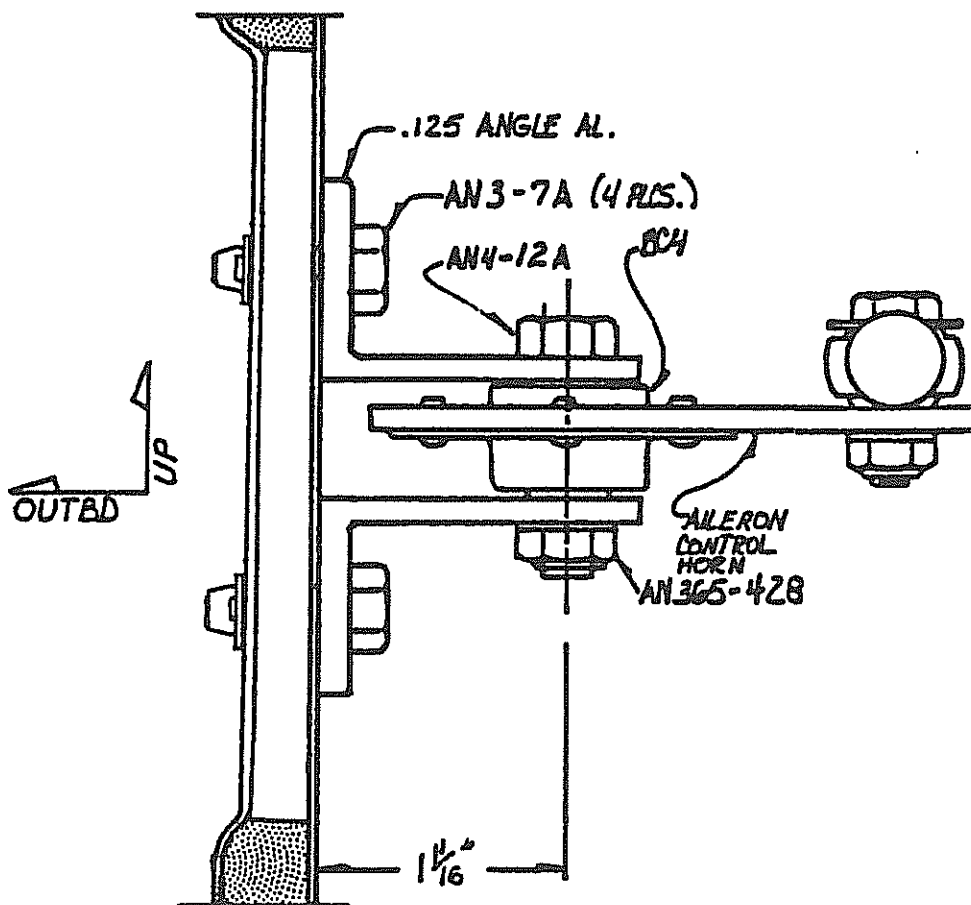

9. If your choice is to cut the slot in the BL-74 rib, do so carefully, and keep the piece you cut out. Using a keyhole saw or coping saw, cut the slot in the BL-74 rib (this will be easier to do if you drill the hole per step 11 first).
10. From the 1-3/4" aluminum tubing provided in the kit, cut to length the transit tube.

NOTE: The transit tube should extend 1/4" - 3/8" beyond the external faces of the fuel tank ribs at each end. This is to provide a surface on each end to make a mechanical bond (BID tapes) of tube to rib on the outside of the tank.

11. Locate the position for the transit tube, and cut the holes into the ribs. You can use a 1-3/4" hole saw to cut the circular holes. If the transit tube requires slight position adjustments for clearance purposes, do so and use micro to fill around the tube as required to seal off the core material.

12. At this point it is best to actually have the push rod to use for a final check. The transit tube and rib assembly will require a preassembly (with push rod slipped into tube) prior to inserting down into the wing. Slip the push rod into the tube and then put the whole assembly into the wing. Connect the push rod temporarily to the bellcrank and idler arm. Check for full rotation per figure 9-8.
If the transit tube must be adjusted, then refit and recheck until clearance is maintained throughout full travel. With full, unrestricted travel achieved, the assembly can be permanently bonded.
13. If you chose to slot the BL-74 rib, now is the time to replace the piece you removed. Using a flat-blade screwdriver or similar, scrape about 3/16" of the core material from the perimeter of the slot, and do the same to the piece you removed.
14. Using epoxy/micro, fill the 3/16" channel in the rib and the piece you removed and, using a little extra micro, re-install the piece in place. A piece of duct tape over each side should hold it nicely until it cures.
15. After it has cured, put 2 BID over both sides of the rib slot, covering the entire piece you removed and extending at least 1 " onto the rib. Let cure.
16. Use micro to pot around the transit tube where it goes through the three ribs.
17. Add 2 BID around the rib to tube junctures. This will require a little patience, as you need to wrap small pieces of glass around the forward side of the tube, since there is very little clearance from the main spar web.

SLOTTING THE BL-74 RIB

Figure 9-12

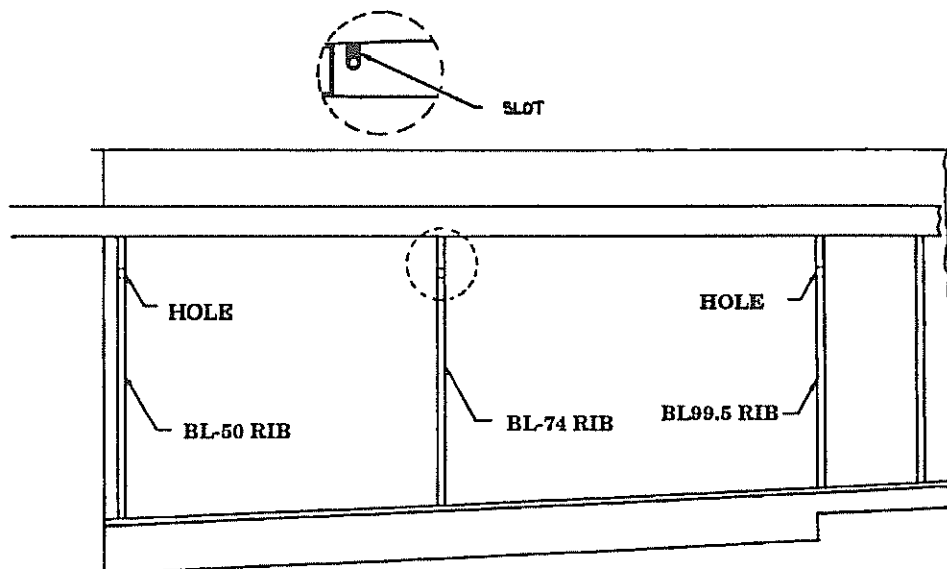

18. Place 2 BID around the rib to transit tube on the exterior side of the fuel tank. Add these tapes to the BL 50 location after the wing is removed from the fslg.
19. Mark the location of the aileron bellcrank bracket attach points on the BL 105.5 rib.
20. Drill the attach holes (#12 bit) through the rib phenolic.

WARNING: Be certain to verify that all four (4) bolt hole locations on the aileron attach brackets are solidly into the phenolic insert in the wing rib. Failure to do so could result in total failure of the aileron controls during flight. Maintain at least 1/4" perimeter in phenolic around all holes.

21. Attach K1000-3 anchor nuts on the outbd side of the rib using the AN426A3-10 soft, flat head rivets trimmed to proper length (see figure 9-8).
22. Use AN3-7A attach bolts to secure the aileron bellcrank assemblies into place.



D. BL 50 RIB MODIFICATION

1. A small phenolic insert must be placed to bond the fuel pick-up line. See figure 9-13. That fuel transfer line is typically a piece of 1/4" aluminum tube (provided you are intending to use the stock fuel system which requires the wing tanks to only "transfer" pump to the header tank). If you intend to run the engine directly off the wing tanks, then the 1/4" line will not be sufficient and **MUST** not be used. Fuel lines directly to the engine must be 3/8" minimum. In addition, such a modified fuel system is much more complicated than it may at first seem. We strongly recommend against altering the basic fuel management without extensive engineering application.
2. Insert this phenolic in the same manner as the one for the aileron bellcrank.



9-25

Chapter 9

REV. 0 / 11-1-91

OUTBOARD WING SECTIONS

WING FUEL TANK INSTALLATIONS

There are several more items that must be installed into the first two bays of the outbd wing in order to convert this area to a fuel tank. This tank will hold approximately 15 U.S. gallons when completed.

E. FUEL PICK UP LINE

With the standard fuel system, the wing tanks are used only to "transfer" fuel to the header tank where it is fed to the engine. The transfer lines can be 1/4" in diameter. This 1/4" aluminum pick up line must be installed next.

NOTE: If you intend to run the engine directly off the wing tanks, then the 1/4" line will not be sufficient and **MUST** not be used. Fuel lines directly to the engine must be 3/8" minimum. In addition, such a modified fuel system is much more complicated than it may at first seem. We strongly recommend against altering the basic fuel management without extensive engineering application.

1. Cut a piece of aluminum line (1/4" dia 5052-0) approximately 18" long. This will be bent to fit into the bottom of the tank, per figure 9-13, and extend to the fwd lower corner. It then will exit the tank through the outbd BL 50 rib. The exit hole must be through the small phenolic insert placed in the rib. The aluminum line will transition fwd of the primary landing gear attachment where a connection can be made approximately half way between the primary and secondary gear attach points in the center section spar.
2. Drill a 1/4" hole through the phenolic insert in BL 50 (outbd) rib. Use a small amount of 9339 adhesive to pot the aluminum tube into position. Also required is a clearance hole in the inbd BL 50 rib. Allow the 9339 to cure.
3. Add 3 BID around the inside juncture of the rib to aluminum line. Add 2 BID around the exterior side of the rib to aluminum juncture. These can be small pieces of BID about 1" wide. It is easiest to apply these one at a time and wet them out on the part. Leave a generous fillet between rib and aluminum tube.

NOTE: The tube ending on the inside of the fuel tank should be placed such that it is about 1/2" outbd of the BL 50 rib and slightly above the bottom of the tank. It is also recommended that a screen "bag" be made around the end of the tube and bonded to it using structural adhesive. The screen should be about 3" long and about 1/2" - 3/4" in diameter. This will prevent any single piece of contamination from totally clogging the opening.

F. FUEL TANK PICK UP LINE SCREEN FILTER

1. Using a flaring tool or equivalent, flare the end of the fuel pick up line.
2. Make a filter from a piece of brass screen, about the same coarseness as used on the finger filter (16 holes per linear inch), 1/2" - 3/4" in diameter, by wrapping it around a suitable sized marking pen, piece of tubing, etc., overlapping itself by about 1/4". The filter should be about 4" long, minimum. Refer to figure 9-13.
3. Run a bead of structural adhesive down the overlap to seal the seam, and let cure.
4. Slip one end over the pick up tube flare about 3/4", and squeeze/roll the filter to cause it to close down to the tube outside dimension.
5. Apply enough structural adhesive to cover the part of the filter overlapping the tube.
6. Using a piece of fine wire, wrap several turns around the filter and tie it off.
7. Coat the wrapped wire with structural adhesive.
8. Crimp the last 3/8" - 1/2" of the filter flat together, and seal with a little structural adhesive.
9. Referring to figure 9-13, bond the tube to the side of the rib at the location shown using 1 BID to attach.

You now have a permanent screen to filter out any "grimies" that might find their way into your tanks.



FUEL TANK PICKUP LINE INSTALLATION

Figure 9-13

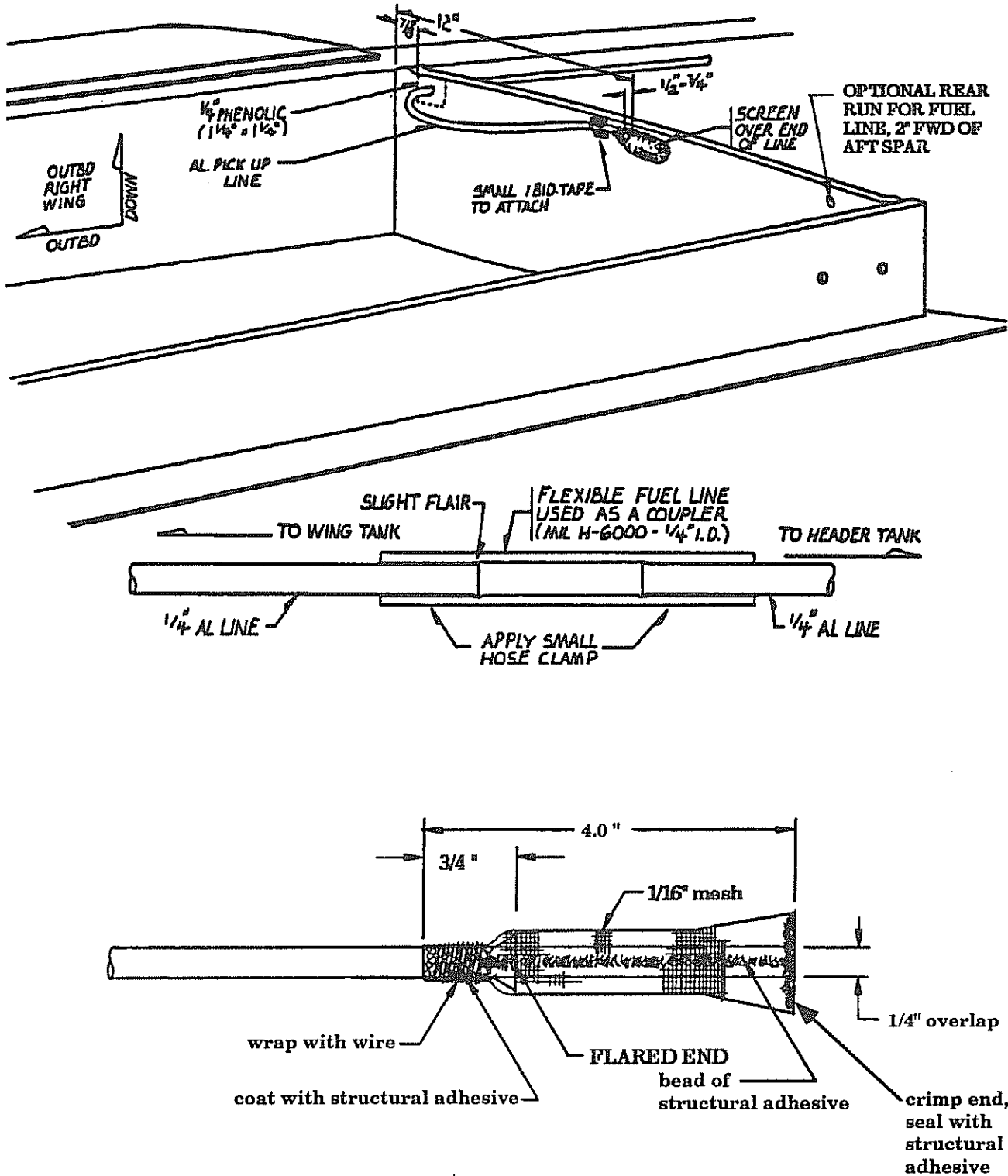

G. Vent line installation

A vent line is required at the upper end of the tank. To help prevent spilling fuel overboard on the ground, the line should be extended just beyond the tip rib. See figure 9-15.

VENT LINE INSTALLATION

Figure 9-14

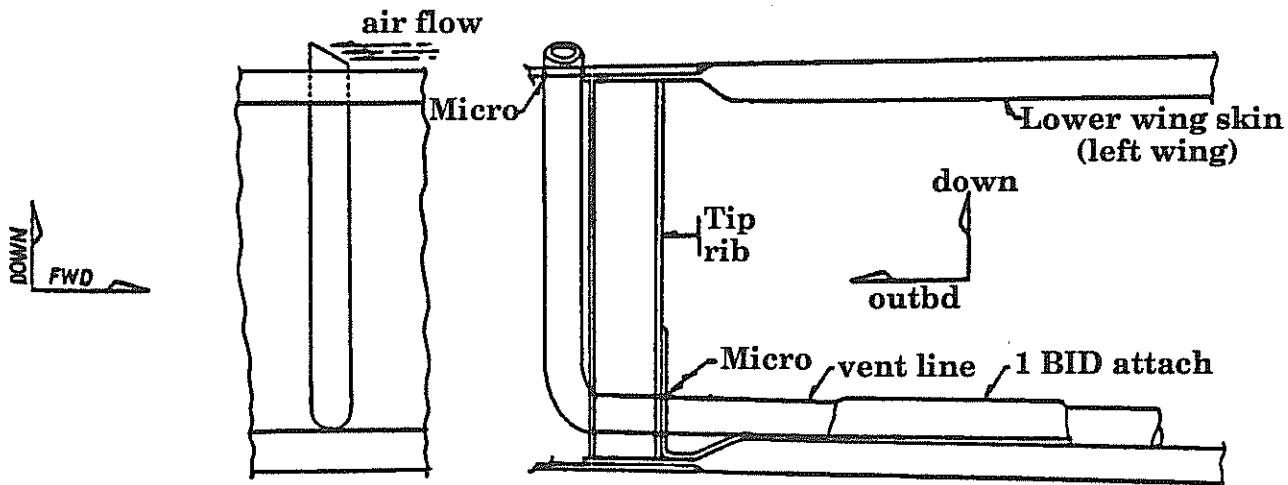

1. The vent line should come fairly close to the fuel tank filler cap and extend outbd. Refer to figures 9-14 and 9-15. Measure the length you will need, being sure to have enough to go from near the filler cap to the tip rib, then bend up to extend 3/8" outside the lower wing skin.
2. Cut it from the 5052-0 aluminum line supplied with your kit.
3. Bevel one end as shown in figure 9-14, being careful to blow out any shavings, etc. that might have found its way inside.
4. Drill the holes through the ribs for the vent line.
5. Slip the vent line into place, bending the outbd end of the tube to shape. A sand or shot bag placed somewhere on the tube should hold it nicely.
6. Place a generous flox fillet around the vent line where it exits the tank and cover with 3 BID. Add 2 BID to the exterior side of the BL 99.5 rib where the line exits.
7. Place a few 1" - 2" long 1 BID tapes to hold the line against the upper wing skin.

8. The line should exit the wing just outbd of the tip rib near the back of the main spar web. The line should extend approximately 3/8" outside of the wing skin (and be slightly bevelled into the air stream by making the angled cut face into the wind to terminate the line).



9-30

Chapter 9

REV. 0 / 11-1-91

OUTBOARD WING SECTIONS

H. Fuel tank baffles

The BL-74 rib also serves as a baffle. The cutouts must have the core completely sealed off. Be sure that there are no rough edges that could snag onto contaminants, nor should there be any corner 'pockets' in the tank that could trap quantities of contamination. A span wise baffle could be added, but that is not required.

1. Inspect the tank area for anything that might trap contaminants, and sand off any you might find.
2. Use epoxy/micro to seal off the core in the BL-74 rib that is exposed by the fuel flow slots.

Wing fuel tank

Figure 9-15

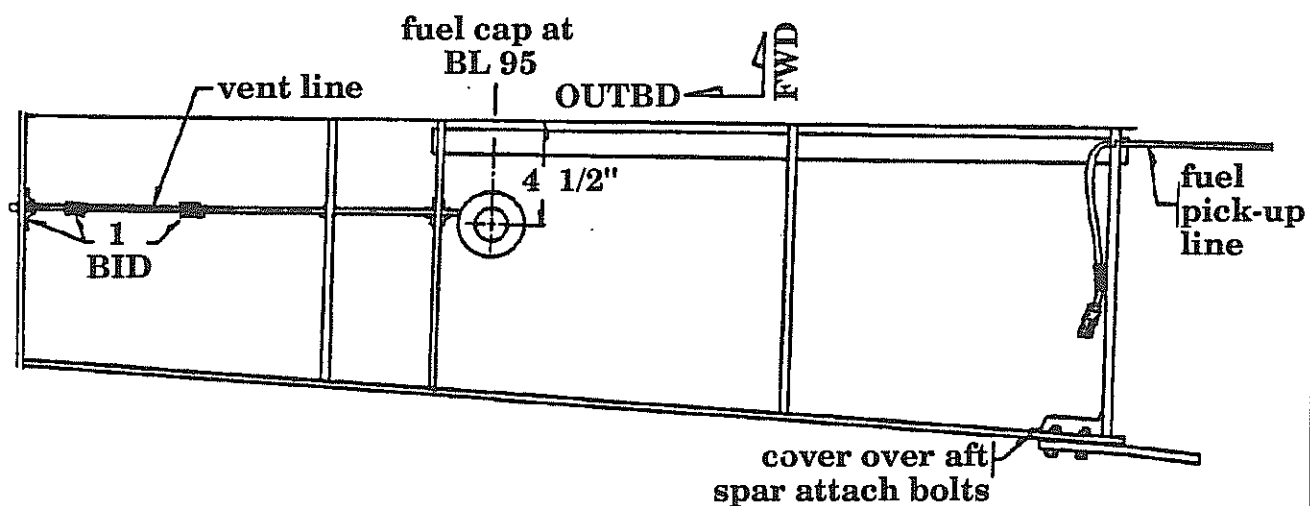



I. Fuel filler cap installation

Your kit is supplied with three (3) filler caps, one for each tank. The Header tank cap is already installed for you, so you can take a look at it for a reference. The installation for the other two is identical in technique.

1. Per figure 9-15, mark the location for the filler cap in the wing skin.
2. Make a circular cut completely through the inner skin, core and outer skin. This diameter should be 2 1/2". Use a hole saw in a drill or equivalent.
3. Next cut a 4 1/2" diameter on the inside skin so that it is concentric with the existing hole. This cut should be made with a rotary type tool and ONLY made through the inner wing skin ply and the core material. See figure 9-16.
4. Scrape away the core and sand a slight bevel into the resultant edge. Be sure to sand all the core away against the outer skin plies.
5. Using 80 grit sandpaper, scuff up the mounting flange on the fuel cap assembly. Note that there is a slight bevel to this flange. Rotate the circular flange until the best curvature alignment is made with respect to the curvature of the upper wing skin itself. Mark this alignment with a pencil on both the flange and skin.
6. Mix up a batch of 9339 adhesive to bond the cap to the inside of the skin.
7. Place plastic tape around the edge of the inner cap and insert the cap in its assembled position. It should be almost flush with the flange (0.030" above is perfect).
8. Spread the adhesive on both bonding surfaces and insert the assembly into the skin.

NOTE: The clamping pressure is very important. It is best to make a curved styrofoam block or equiv. to fit to the outside contour of the wing skin and support it there. Place some weight on the inner side, against the fuel cap assembly to hold it snug against the skin during cure. Use about 10 lbs.

9. With proper weight, and pressing against a well contoured foam block, the cap will end up flush with the surface of the wing. Some 9339 could ooze out, which is why the cap is covered with plastic tape as a release. Otherwise it might get bonded into the mounting ring.
10. After cure, add 2 BID around the inner flange.



Fuel filler cap installation

Figure 9-16

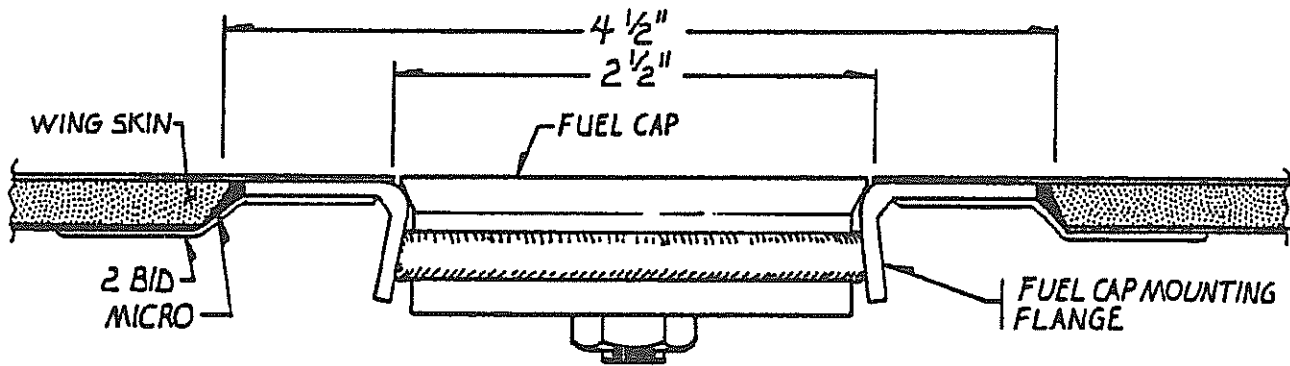

J. Aft spar attach bolt covering

The two AN365-428 nuts which hold the aft spar attach bolts to the aft spar must be covered to prevent possible fuel leakage. Your kit, if shipped after 1/1/90, will contain a pair of spar attach bolt covers. By using these covers as shown in figure 9-17, you will be able to remove the bolts without cutting into the fuel tank, should the need ever arise.

1. Using structural adhesive, and being very careful to use enough to seal but not get any on the threads or nuts, bond the covers to the wing aft spar and BL 50 rib as shown in figure 9-17. You don't have to cut the hole in the BL 50 rib until a need arises to remove those two bolts but in this manner, you'll be able to reach the nuts if required without entering the fuel tank. Thus, this block must go all the way to the BL 50 rib face.

Fuel tank / aft spar bolt cover

Figure 9-17

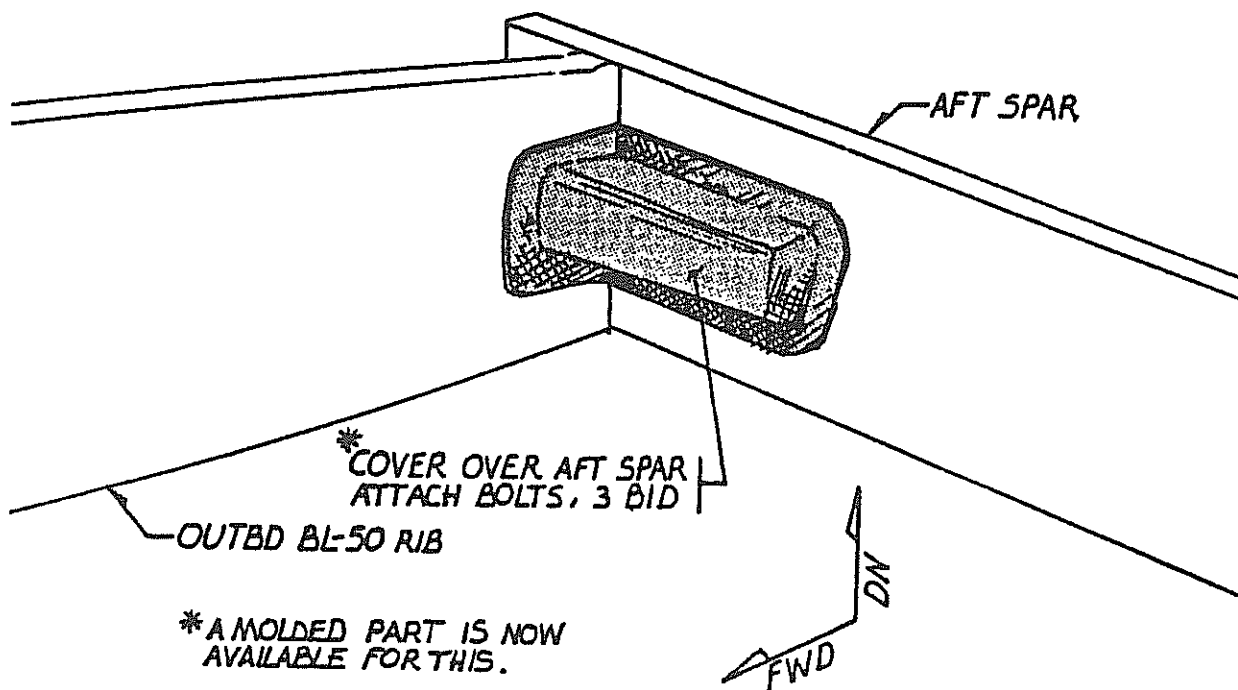

K. Lower outbd wing skin installation

This lower skin will be fitted in a manner used to achieve a perfect fit. The lower skin will be fitted and released. Obviously any items which will eventually mount into the wing must be installed prior to closing out the wing. Those items are:

1. Fuel tank completion with sealer, sump drain, filler, vent tube.
2. Wing tip extensions*
3. Extra fuel bay*
4. Nav antenna
5. Transponder antenna** (can instead be mounted in cockpit area).
6. Auto pilot roll control*** (can instead be mounted in cockpit area).
7. Wing tie down points (optional - if you want to use ours, call Neico now for the parts so you'll have them when it's time to install them - on page 9-40).

*If you are considering the extra fuel bay or wing tip extension options, contact Neico now so you can have the information on hand later when you will need to make the final decision (about page 9-39).

**Suggested mounting area is in the belly or aft compartment, providing several benefits - no disconnect to remove wings, shorter lead lengths, easier access.

*** If you want to install the auto pilot roll control in the wings, contact Neico for the optional blueprint that outlines this installation. Call now, so you'll have it before time to close out the wing.

We will go through the sequence to prepare the wing for sealing, and then, prior to closing it out, go over the above list again.

1. First trim the L.E. of the lower wing skin where it will **BUTT** to the "D" section of the upper wing skin (over the lower spar cap). This is a 1-1/2" joggle, but not a critical dimension.
2. Fit the lower skin into position and mark for the BL 50 trim line. Note that since the ribs and aft spar are probably a little high, the skin will set loosely over them and a close, accurate alignment will not be possible. That will be o.k. for now.
3. Check the wing tip alignment joggles and align with the upper wing skin joggle.
4. Drill the 1/4" hole to let the fuel tank vent line protrude.
5. The BL 50 rib (on the outbd wing section) can be sized directly off the skin line generated by the stub wing. The rib will be 1/16" below contour to allow for the wing skin thickness of the outbd lower skin.

6. The wing tip rib is similarly sized (this should have been done already, but it wouldn't hurt to double check against the blueprint).
7. Since the BL 50 rib at one end and the tip rib at the other end are sized, and since the wing is a straight taper, the ribs between can be sized by simple use of a long straight edge spanning from BL 50 rib to tip rib (refer to figure 9-18). The ribs can be quickly sized down by using a 4" electric hand grinder. Be careful, since these grinders cut fast.

NOTE: It is important that when laying the straight edge across the ribs to establish sizing, **YOU MUST BE AT SIMILAR STATIONS ON BL 50 AND TIP RIBS** (i.e., if you are at a 30% of chord station on the BL 50 rib, be at a 30% of chord station on the tip rib, which will be a shorter linear dimension since the rib is shorter).

This % of chord is not too critical however, just be "eyeball" close. This above method is good enough to get quite close in dimension. HOWEVER, the 1/4" - 5/16" core material thickness must also be accounted for. You must subtract 1/4" - 5/16" additional along the inner ribs where they contact the core material.

Trimming ribs

Figure 9-18

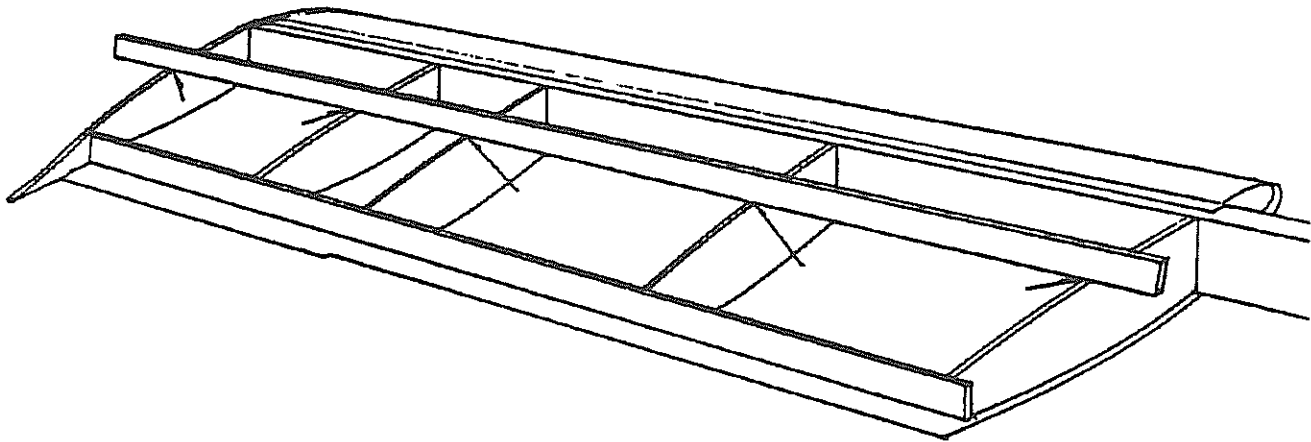

8. With the ribs sized fairly close, lay the lower skin into position and check for contact and interference by lifting the skin very slightly at various points and sighting underneath.

9. Two or three "fit checks" and adjustments will usually get the ribs and aft spar sized correctly. Be sure that you don't get too much crown left into the lower surface. The lower wing skin tends to curl back away from the mold slightly, thus inducing additional curvature. This is very easily taken out provided the ribs will allow it to be taken out when bonded. Again, a straight edge over the skin, when laid in position, will tell the story.
10. When the ribs are fully sized, check them against that straight edge placed along the full span of the outboard wing section. The clearance dimensions between straight edge and rib surface should be fairly constant from rib to rib.
11. Prepare the edges of ribs for a compression bond by scraping back the core to expose about 1/8" of surface ply on both sides. You will fill this "trench" with epoxy/micro.
12. Mark off the inside of the lower skin where all ribs will be contacting it and cover those areas with plastic packing tape. It will serve as a "release". Tape should extend at least 1" in both directions from the ribs.

Note: The next 5 steps have to be done in the working time of the epoxy you will mix, so be sure you mix enough for the amount of the job you intend to do. You will be putting micro into the channels of the ribs, and putting a 1 BID layup onto the lower wing skin, then putting it all together so that it can cure as a unit.

13. Prepare a 1 BID tape for each rib, that will be 1 1/2" wide and as long as the rib.
14. Place the BID tapes on the inside of the lower wing skin such that it will be centered over their respective ribs when the skin is in position.
15. Mix up and apply a generous amount of epoxy/micro to all rib channels, sufficient to fill the channel and just a bit more to give a good bond.
16. Lay the lower wing skin into position and weight it down to proper contour. A straight edge can be clamped along the T.E. Use plenty of weights over the span of the skin. You need approximately 100-150 pounds.
17. **RECHECK YOUR WING TIP INCIDENCE BY CHECKING WITH A WATER LEVEL. SUPPORT THE WING SO THAT WHEN ALL THE WEIGHTS ARE APPLIED, NO BOWING OR TWISTING RESULTS.**

Now allow to cure.

18. After cure, remove the weights and remove the wing skin.

19. Trim the rib caps so that they are about 1-1/2" wide, and extend over each side of the ribs evenly. A heat gun and sharp knife works good for this.

20. Clean off any excess micro that may have squeezed out with either a utility knife and heat gun, or grind it off.

21. Make sure full contact was made over length of ribs. Any spots where the 1 BID tape is not fully bonded will be taken care of in the next step.

22. Using epoxy/micro and a modified tongue depressor, make a 1/4" radius fillet between the rib caps and the ribs as shown in figure 9-19. As you do this, inspect all BID for voids between BID and rib, filling with micro as you go along.

23. Prepare 2 BID tapes to be used as shown in figure 9-19. These tapes will go on both sides of each rib, extending from the edge of the cured rib cap, down across the micro fillet, and onto the sides of the ribs.

24. Use your brush to "stipple" the tapes into place, removing any trapped air from beneath the tape. Use care here - you could add a lot of weight that isn't necessary at this point by leaving excess epoxy. Use only what is necessary to wet out part and get a good bond.

Rib caps
Figure 9-19

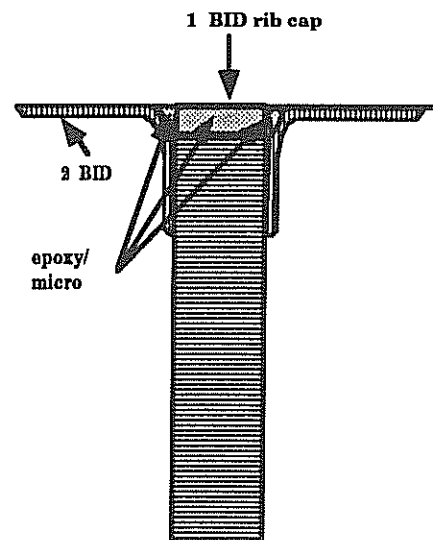
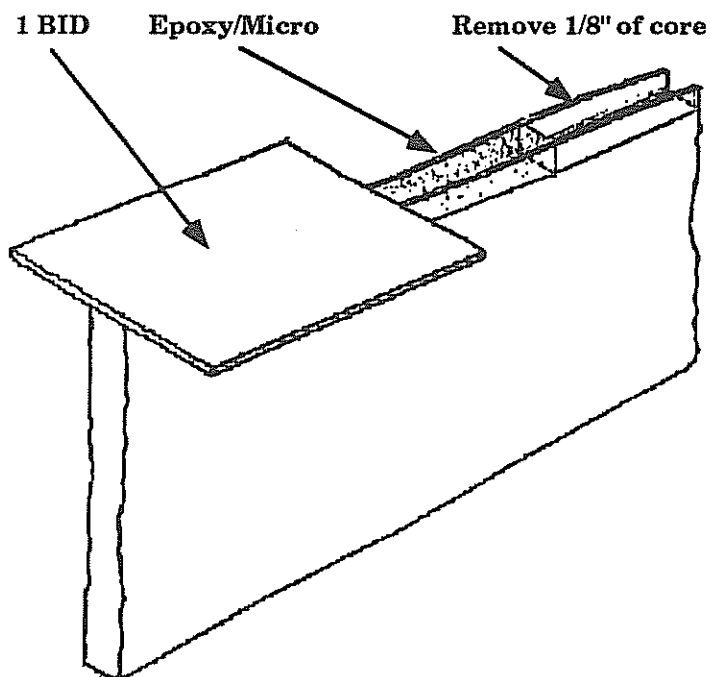

The lower wing skin and ribs are now prepared to fit nicely together, but we still have some unfinished business to attend to before closure;

NAV and Transponder antennas - If you are going to mount these in the wing instead of the fuselage, proceed at this time to the ANTENNA INSTALLATION SUPPLEMENT, and perform those steps, returning to here when finished.

Auto Pilot Roll Control - If you are going to mount the roll servo in the wing instead of the fuselage, refer to the drawings you got from Neico when you called them back on page 9-35, and do those steps now, returning here when you are finished.

Wing Tie Down Points - If you've decided to install these, now is the time. Proceed with the instructions starting below.

If you have finished with all of the above considerations, all that is left is the **sump drain installation** and wing closure. Proceed to page 9-42, and get back to work.



L. Wing tie down points (Optional Pcs)

Wing tie down points can be installed in a variety of ways. This will describe installation of our tie down rings, available as an option. See figure 9-20. It is best to have the lower wing skin fully fitted (but not bonded) before installing the tie down plates.

1. Locate a position on the aft face of the outbd main spar. This position is not critical. If it is located between the BL-99.5 and BL-105.5 ribs, then there will be access to it after the wing is sealed. However, there is not much reason for access. When positioning this plate, note that adequate clearance must be maintained from the aileron push rod through full travel.
2. Note that the barrel length of the receptacle is set by the manufacturer such that the locking pin must be tight against the barrel in order for the locking "balls" to engage. This surface plane must be in alignment with the lower outside wing skin surface. Therefore the barrel must extend through the 1/4" thickness of the skin core.
3. Grind the flat plate back such that the barrel does extend 1/4" beyond the plate.
4. Drill the flat back plate with several holes (1/4" dia. is sufficient). This is to provide floc penetration. The hole pattern is not critical.

Wing tie down installation

Figure 9-20

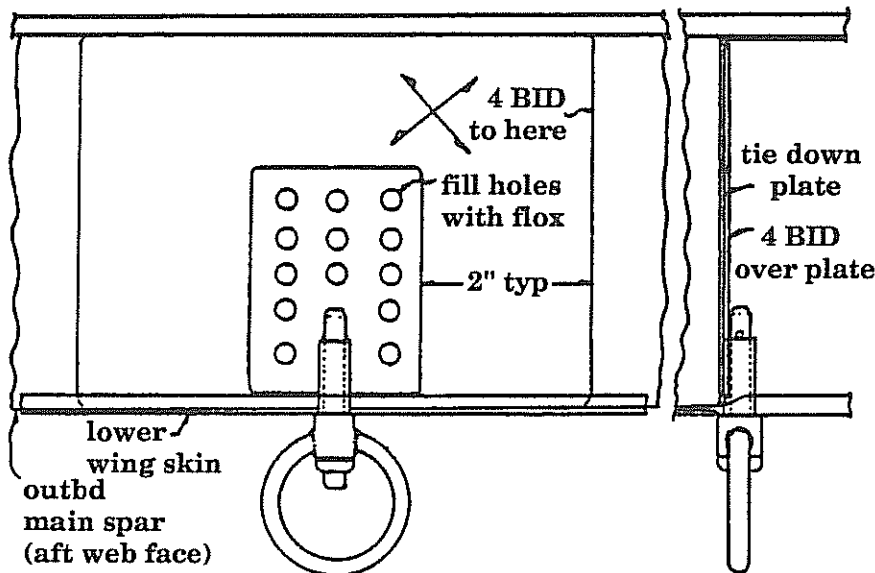

5. Position the plate against the back of the main spar web. Locate the barrel such that it extends about 3/16" - 1/4" beyond the spar cap lower surface. You may have to file the barrel down slightly after the skin is attached but it is better to have the pin net out a little long for the barrel (thus an easy engage of the lock pins) than to have the final assembly of barrel and skin total something that is a little too long for the pin (thus not allowing the lock pins to engage at all).
6. Attach the plate to the web with epoxy/flox and 4 BID over it. Contact 2" onto the spar web all around. Use a couple of small dabs of hot glue to hold the plate in position or simply clamp it with flox only and later add the 4 BID.
7. When you refit the lower wing skins, you'll have to mark and drill for the barrel hole through the skin surface. This is a 3/8" hole.
8. If the barrel protrudes beyond the surface of the skin, simply file until it is flush with that surface. Don't file for this alignment until you have bonded the lower skin into position to verify the surface level. Also note that there is usually a small amount of micro filler required to fair the lower surface contour in with the fwd "D" section through the 3" BID tape area over the spar cap - allow for this dimension as well.
9. If when you are finished, you have a difficult time engaging the lock pins when inserting the tie down ring, it is probably because the pin is not getting deep enough into the barrel. Relieve the skin surface as required.



M. Fuel tank sump drain installation

1. After the lower outbd wing skin has been fitted, the sump drain block (#FU3, supplied in your kit), which is drilled and tapped for 1/8NPT, should be installed into the lower win skin per figure 9-21.
2. Per figure 9-21, bond the 1" square block to the lower outbd wing skin. Be sure that the pipe threads are properly oriented so the taper decreases towards the inner side.
3. Place 3 BID over this block.
4. Use either an F391-18 flush drain or the Curtis type quick drain. The flush type is preferred.
5. A nice fairing can be easily made to fair in the head of the drain on the exterior of the wing. Place a socket over the drain and put micro around it. Wrap the socket with plastic tape first so it will release. Remove the socket after the micro cures and sand it to a smooth fairing around the head of the drain. This automatically provides adequate clearance to slip the socket on for installation and removal.

Fuel tank sump drain installation

Figure 9-21

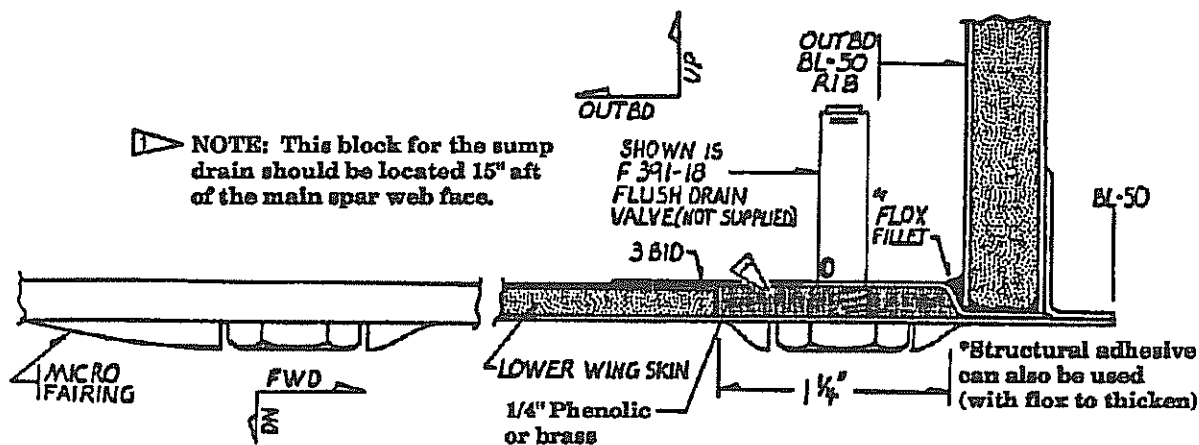

N. Aileron inspection panel

One aileron inspection panel is required in each outbd wing. See figure 9-22 for size and location. The method of construction is as follows.

1. Using a sabre saw, cut out the panel completely through the skin.
2. Place plastic tape over the inner skin of the panel and replace the panel in the skin.
3. Hold the panel in position with tape or mixing sticks held down with hot glue.

Aileron bellcrank inspection access panel

Figure 9-22

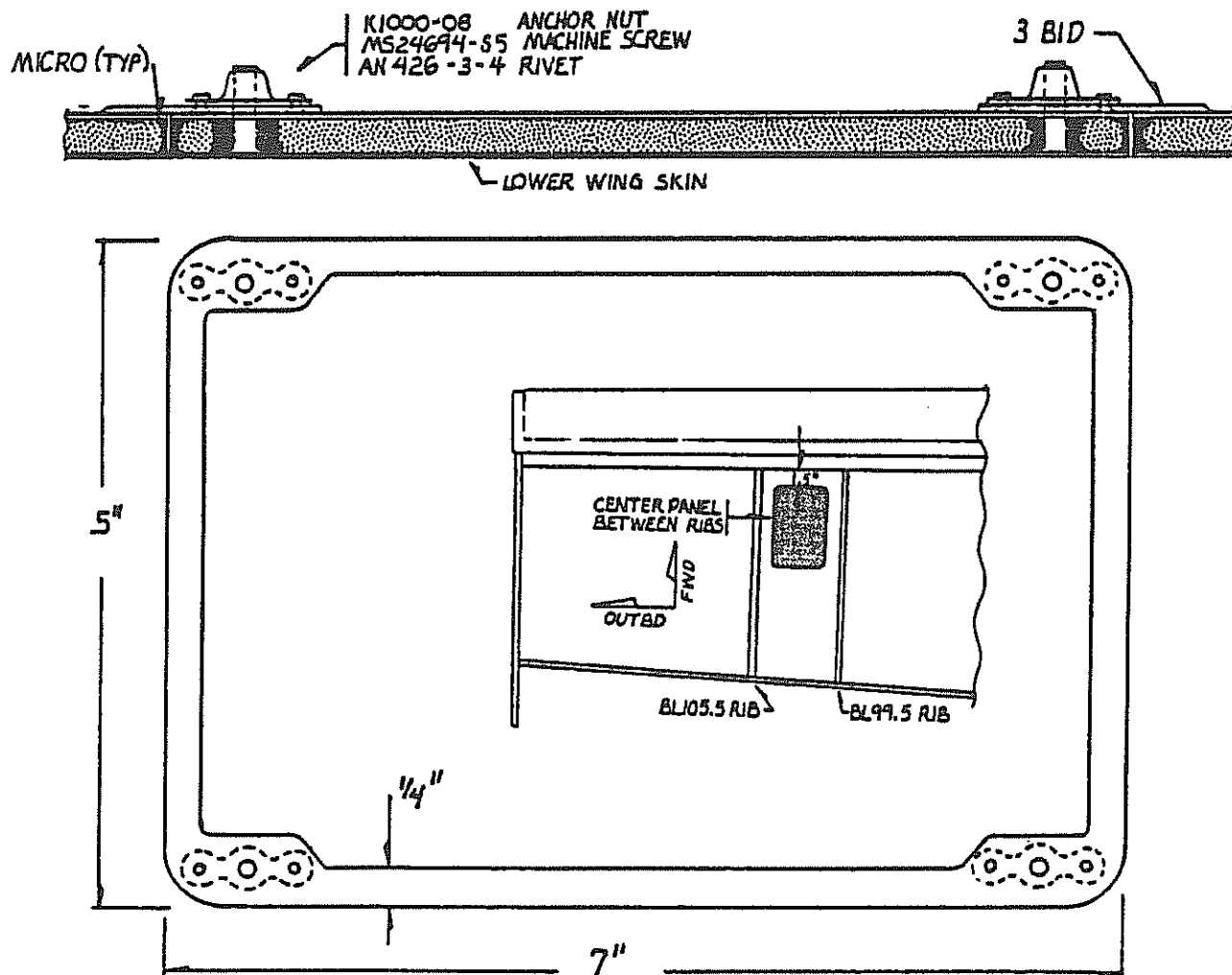

4. Add a 3 BID tape around the perimeter on the inner surface. It will contact about 3/4" onto the win skin and hang over the panel by about the same 3/4".
5. After cure, remove the panel and trim the 3 BID down to a 1/4" width except for where the anchor nuts are installed. Make those 4 areas larger as required to mount the K1000-08 anchor nuts.
6. Scrape the foam back in the wing skin and fill with micro.
7. Drill a #19 hole for the 4 attach screws. From the inner surface of the inspection panel, grind out the core material around the holes and fill with micro from the back. Allow to cure. After cure, redrill to the holes and countersink with a 100° countersink. Attach with 4 MS24694-S5 screws.

NOTE: IF YOU ARE GOING TO INSTALL THE WING TIP EXTENSIONS, DO IT NOW, and return here after completing the instructions in the wing tip extension supplement.



9-44

Chapter 9

REV. 0 / 11-1-91
OUTBOARD WING SECTIONS



O. Fuel tank sealer installation

There are several methods of sealing an integral wing fuel tank. The following is one method which works well. It will utilize PRC 1422A fuel tank sealer and #420 primer. We have used PRC 1422A with #420 primer in our aircraft and to date have had no bad effects from it's use. However, as with any after market products, Neico can not warranty them beyond any manufacturers warranties, disclaimers, etc.

NOTE: If you use this tank sealer, it should not be painted in until the lower wing skin has been completely fitted and is itself ready to be bonded into permanent position.

PRC 1422A and #420 Primer Installation

1. There are two parts to the process. First is a primer which, even from PRC engineers, is in debate as to it's true need. However, we generally use the primer. The second is the actual sealer.
2. Clean and prepare the tank interior in the usual manner as you would in preparation for any fiberglass wet layup.

WARNING: These materials are very toxic and require good ventilation. A good charcoal respirator mask should be used along with protective gloves.

3. Carefully mask off ALL the areas where the lower skin will bond to the wing. Use masking tape on the lower skin.
4. Mix the #420 primer. It is a two part system that is a bright orange in color.
5. Paint the sealer onto the inner surface of the lower wing skin using a wide brush. You will need to use a smaller brush to coat the ribs, up under the BID caps. Allow to cure for 24 hours. This will be a highly "tacky" surface. You may, depending on where you are building the plane, want to cover it to keep out the bugs, dust, or other things that may be circulating in the air.
6. Next mix the 1422, **but only in small batches.** The 1422 will cure rather quickly so only small pint batches should be used, one at a time. It is also a two part system and very toxic.
7. The 1422 is very thick and can be thinned with MEK or Toluene (the second is better, the first is easier to locate, and both are toxic). MEK in particular will accelerate what is already a pretty fast curing material so be completely ready when you mix it and work quickly. Dilute only by 10-15%.

LANCAIR® 320FB

9-45

Chapter 9

REV. 0 / 11-1-91

OUTBOARD WING SECTIONS

8. Brush and / or squeegee the 1422 over the tank interior surfaces. Cover all surfaces with a smooth coat. Allow to cure for 24 hours (it will still feel tacky and will continue to feel tacky for weeks - that's o.k.).
9. Apply a second coat of 1422 and allow to cure for 24 hours.
10. Remove the masking tape which was a barrier from both the lower wing skin and the wing.
11. Check that the vent and pickup lines are clear and not filled with sealer. Check that the pipe threads for the drain are clean.



9-46

Chapter 9 REV. 0 / 11-1-91
OUTBOARD WING SECTIONS



P. Final closeout of lower wing skin assembly

1. When you are ready to bond the lower skin into position, coat all surfaces with 9339 structural adhesive, and use it **generously**.

IMPORTANT: Apply the 9339 over the top of the tank sealer by about 1/8" on the lower wing skin surfaces where the masking tape was applied. This will assure a fuel proof surface since all surfaces will be covered with primarily sealer but also 9339 adhesive along these taped off positions.

2. Position the wing skin and apply weights to hold position. The weights and clamping procedure should be similar to that used when setting the micro and the rib caps.

RECHECK YOUR WING TIP INCIDENCE WITH YOUR WATER LEVEL. AFTER THIS THING DRIES, THERE WILL BE NO CHANGING IT. SUPPORT THE WING SO THAT WHEN ALL THE WEIGHTS ARE APPLIED, THERE IS NO BOWING OR TWISTING.

3. ALLOW TO CURE.

4. After the skin has cured in position, remove the weights, prepare the L.E. joggle (over the lower spar cap) and add 3 BID along this joggle. They should be 3" wide.

DO NOT RUN THESE BID TAPES OVER THE JOGGLED AREA WHERE WING TIPS WILL ATTACH. STOP SHORT OF THAT FWD-AFT TIP JOGGLE.

5. Remove the aft spar attach bar and remove the aluminum shim that represented the BID you are about to install.
6. Add 2 BID along the entire wing T.E. where the lower wing skin meets the aft face of the aft spar. These 2 BID will run from where the 2 BID attaching the upper wing skin to the aft spar stops, across the remaining half of the aft spar and across the lower wing skin as shown if figure 9-6.
7. Apply 8 BID additional where the flap hinges attach, refer to figures 9-2 and 9-6. You can easily add these additional BID immediately after applying the 2 BID attach tapes.

Q. Flap hinge positions on lower outbd wing skin
 Refer back to page 9-9, fig. 9-2. There are three flap hinge locations. These hinge sections each measure 10-1/2" long. Similarly to the aileron hinges, the hinge sections must sit flat on the surface of the skin, there must not be any core material interference. Core material can be removed if necessary. Remove only as much core as is required.

1. Per fig. 9-23, locate the flap hinge positions onto the lower wing skin surface.

Flap hinge installation

Figure 9-23

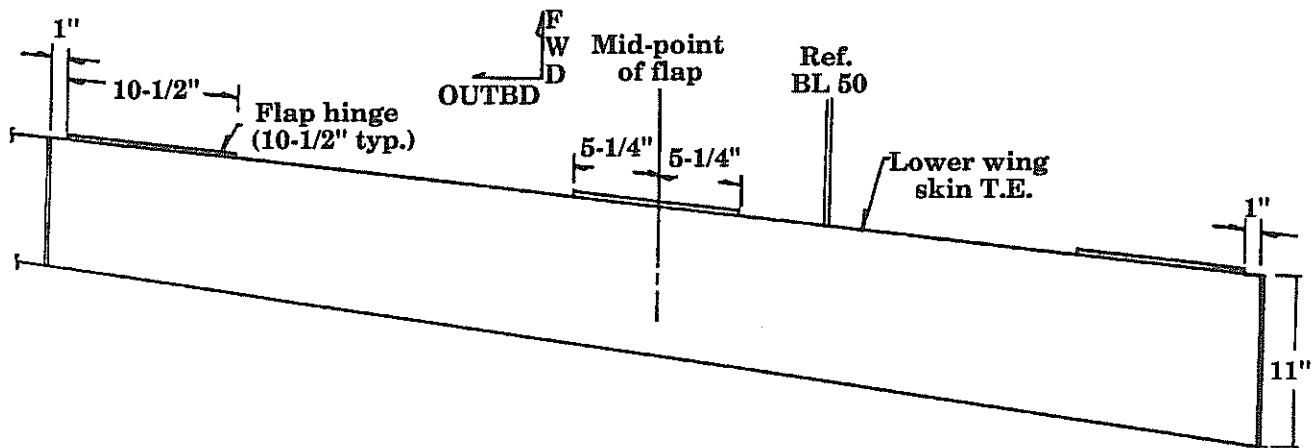

2. Per fig. 9-2, (page 9-9) mark out the trim line of the lower skin T.E. and trim to size.
3. Prepare the surfaces and add 8 BID. These BID must run fully to the skin T.E. and also 1-1/2" up onto the aft web face. At the location of the aft spar attach bar, run up to the base of the bar thus not affecting its alignment.
4. Make the notches into the lower skin to fit the hinge sections, see figure 7-10, page 7-15 for typical hinge installation into a skin. A rotary tool cutter with a small circular cutter works well for this notching procedure.

R. WING TIP INSTALLATION

The wing tips are a two part assembly (upper and lower). They are designed to install over the wing tip joggle on the wing skins. The standard approach is to make a permanent bond. It is possible to make the tips removable but that will require considerably more work with no real advantages.

1. You'll need the wing tip jig to locate the correct T.E. position for the tip so set the wing up with this jig in position.
2. First trim to approximate size. The outbd joint line has a 1" joggle in it.
3. Fit the upper part into position and temporarily set with one or two clecoes. It will fit over the tip rib and up to the outbd edge of the aileron. Leave a 1/16" gap at the aileron.

The tip rib T.E. may require additional size reduction in order to fit the wing tip smoothly.

Wing tip installation

Figure 9-24

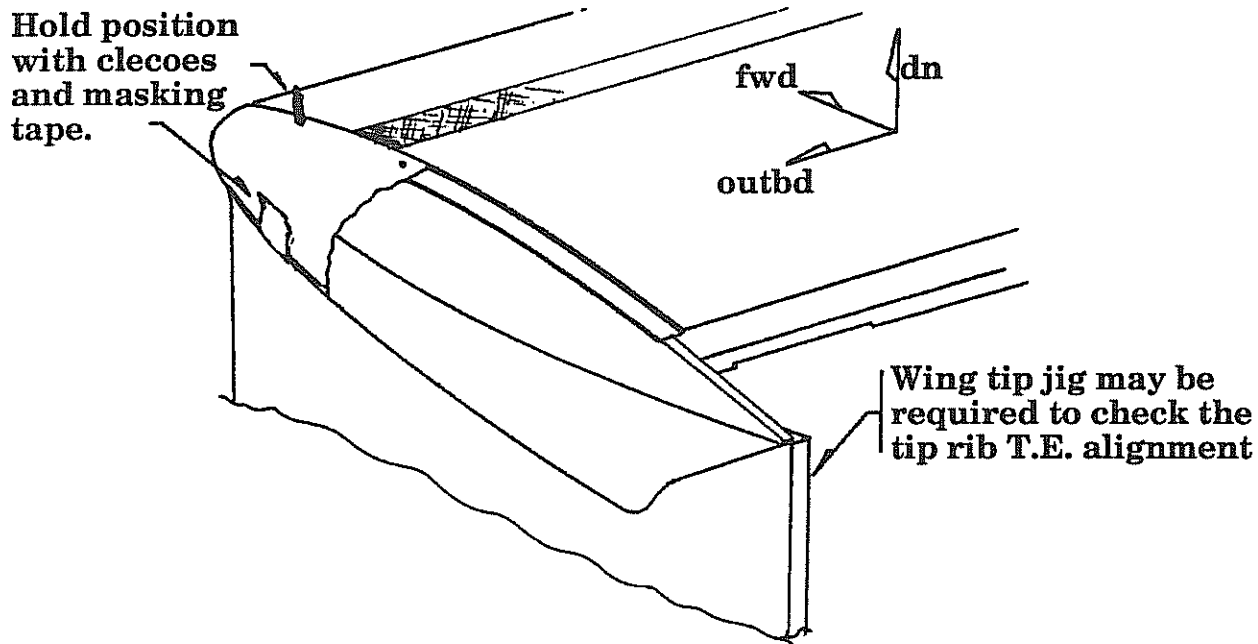

4. Fit the lower portion of the wing tip by butting it to the upper tip and fitting into the joggle of the lower wing skin. Use a couple of clecoes to hold position on the lower wing skin and pcs of duct tape to hold outbd and T.E. tip alignment initially.

NOTE: The T.E. of the wing tip will be approximately 3/32"-1/4" thick. That is because the aileron itself will be made with this 1/4" thick T.E.

5. When the fit onto the wing and the upper/lower tip alignment is satisfactory, apply a 2 BID tape around the perimeter where the joggle is. This joggle should be sanded down first to remove the primer.

NOTE: It may be easiest to add a couple of small 1 BID strips (1" long) to initially hold alignment. Then remove the duct tape and apply a 2 BID strip full length.

6. With the wing tip halves bonded together on the outside joggle, remove the tip. Add 1 BID along the full inside seam. Allow to cure.
7. With the tip now as one piece, a clear wing tip lens for lights can be installed. It is also possible to mount the external lighting system.
8. After any lighting requirements on the wing tip are met (see following discussion and installation), the wing tip can be permanently bonded into position using preferably structural adhesive. It is best to simply clamp the tip in position during the bonding process or lay the tip in the wing tip fixture and weight it from the bottom thus generating uniform pressure all around. The T.E. where it aligns with the aileron can be taped during the bond.



S. Wing tip lighting

Some discussion of available wing tip lighting packages is now in order since installation approaches will be affected.

Without doubt, the easiest (by a significant margin) lighting approach is with our optional three in one Whelen lighting kit (Type 1 lighting kit). This Whelen A-600 assembly incorporates all the FAA required lighting and anti-collision light requirements into a pair of externally mounted housings. They are excellent and are as light as anything you could install. They also are fully on the exterior of the wing and some builders do not like those things protruding from the wing tip. From a drag standpoint, it is a very small penalty in increased parasite drag, probably not measurable on an airspeed indicator. But granted, it is not the most attractive approach to lighting and our builders are often quite conscious of the appearance of the Lancair. That appearance, after all, played a sizable role in their decision to build in the first place.

For that reason, we have developed a much more "flush" lighting system also using Whelen light modules. It too meets all FAA requirements. With this second system (Type 2 lighting kit) the position lights (red / green) are buried beneath clear lenses in the wing tip, a strobe lens protrudes from the central area of the wing tip edge. A standard tail light is attached to the rudder. Our first production Lancair 320 has small tail lights flushed into the T.E. of the wing tips thus two tail lights (Type 3 lighting kit). This is a very attractive package and a lot of work.

Cost? The all in one (Type 1) and the flush system with rudder tail light (Type 2) are comparably priced, the third described with molded T.E. tail lights (Type 3) would cost a bit more primarily due to the addition of one extra tail light assembly.

If you are not installing lights or installing the all in one (A-600) unit, then the tip can be bonded on and the lights installed afterward. For that reason, we'll now discuss the flush mount system (Type 2).

TYPE 2 - Wing tip lighting

Figure 9-25

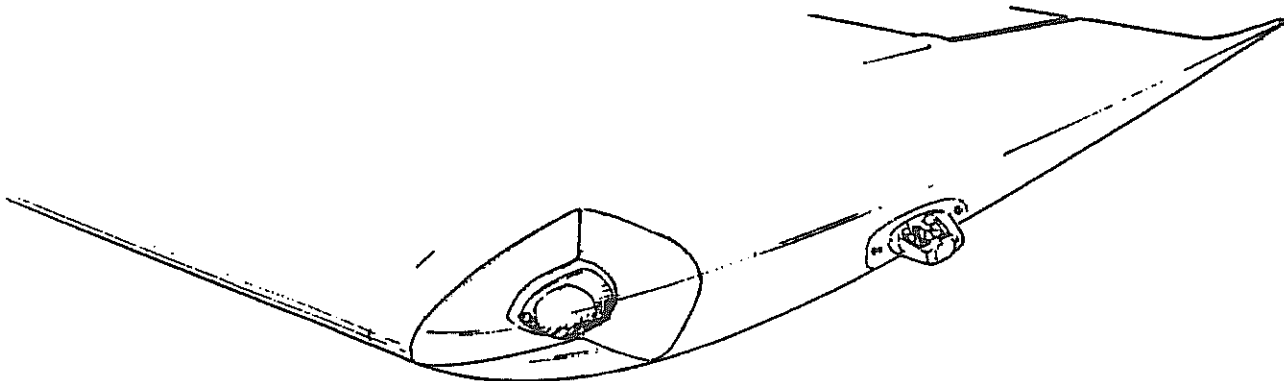

1. Select the wing tip lenses (clear) and unwrap them.
2. See figure 9-26 and locate the trim lines on the L.E. of the wing tip. Mark them on with a marker pen.
3. Hold the lens over the tip and sight downward. In this manner, you can align the lens (which has excess material on it) for the best surface alignment. You will only be able to estimate the exact position since the tip lens will not full slip into position, but you can come quite close.

Transfer these trim lines onto the lens and trim it using a rotary tool with a small circular cutter. Hold it firmly so as not to allow excessive vibration which could generate a crack.

4. Next trim the tip to your marking line. Any small adjustments can be made in the tip much easier than in the lens. Fit the lens into a flush butt-joint alignment.
5. Before you go much further, cover the lens (inside and outside) with protective tape. Use plastic packing tape since you'll need a "release" film on the inside.
6. Place the lens in position. It can be secured with duct tape and small mixing stick pcs if required to hold a close, flush alignment with the exterior wing tip surface.
7. Next add a 3 BID tape around the inside perimeter. This tape should contact about 3/4" onto the tip and 1" over the lens to form a joggle lip. Allow to cure.
8. After cure, trim the lip to a uniform width. The joggle should be wide enough to allow a 3 BID closeout (see step 10 below) and still leave enough room to attach 4 to 6 K1000-06 anchor nuts. A 3/4" lip is sufficient. In this way, the anchor nuts will not show inside the finished lens/light assembly.
9. Drill the lens for the machine screw attachments and carefully countersink them.
 NOTE: Use only two (2) screws top and two (2) bottom to anchor the lens. Place these screws in areas which are relatively flat. Position the light unit to note its relative position before drilling for these screws since it is possible to locate a screw in a position which could be in conflict with the light body.

Next a light housing will be made. There are two methods for this, method one will ultimately require a separate inspection hole for the strobe light, the second method will result in a simplified through-hole for the strobe light but will also require that you reach your hand through the fwd hole where the clear lens is installed. If your hand will fit through o.k., it is perhaps best to use the second strobe light installation method.



Wing tip lens

Trim Orientation

Figure 9-26

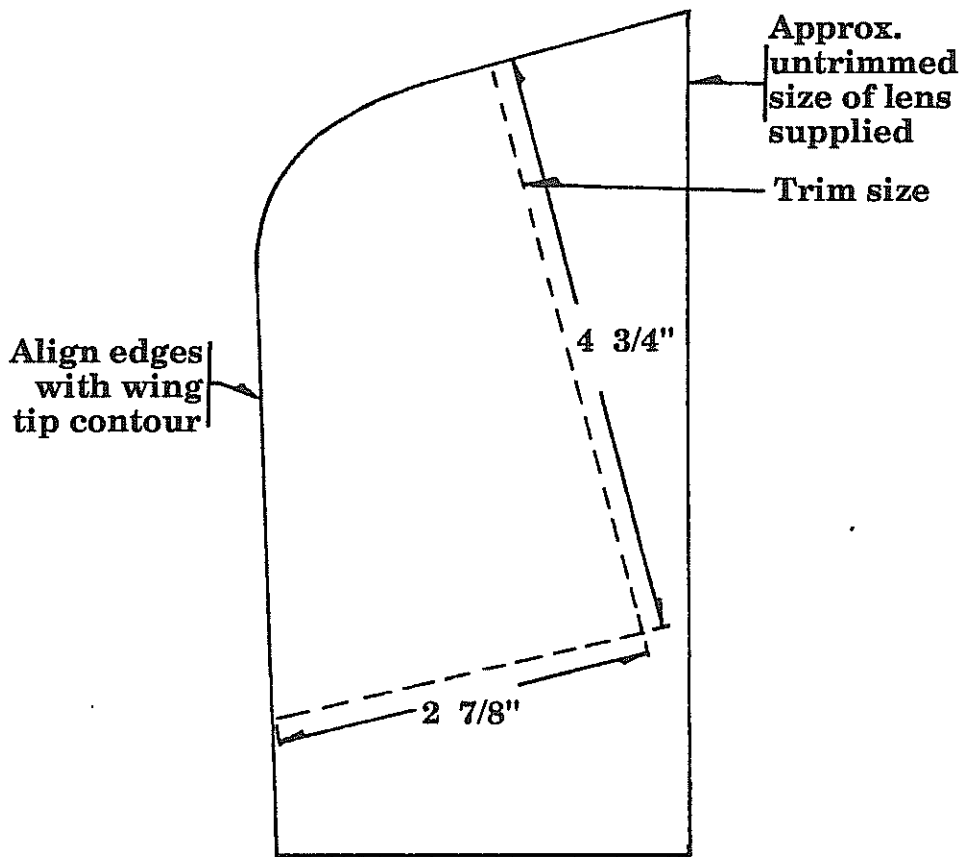

Method 1 - Requires a separate inspection panel for strobe:

10. The colored position lights are designed for an inside corner mount. They have three attachment holes suitable for flat head screw attachment. To box out the lens area, simply lay stiff cardboard or equiv. with plastic release tape tightly against the outside edge of the joggles where the lens fits over. Now from the inside of the tip, lay 3 BID over these plastic covered surfaces and attach onto the inner side of the wing tip.

NOTE: Use care to achieve a nice tight 90° corner which is required for a clean installation of the Whelen light unit. Allow to cure. Remove the plastic coated cardboard and you will have a custom installed closeout on two sides. Use micro to clean up the edges, etc.

- Next fit the Whelen position light unit. It will fit into the corner and attach with three flat head machine screws. You'll need to cut a 1-3/8" diameter hole to insert the base of the light unit through the 3 BID closeout. Attach with machine screws and K1000-06 anchor nuts.

Wing tip position lights

(cross sectional view)

Figure 9-27

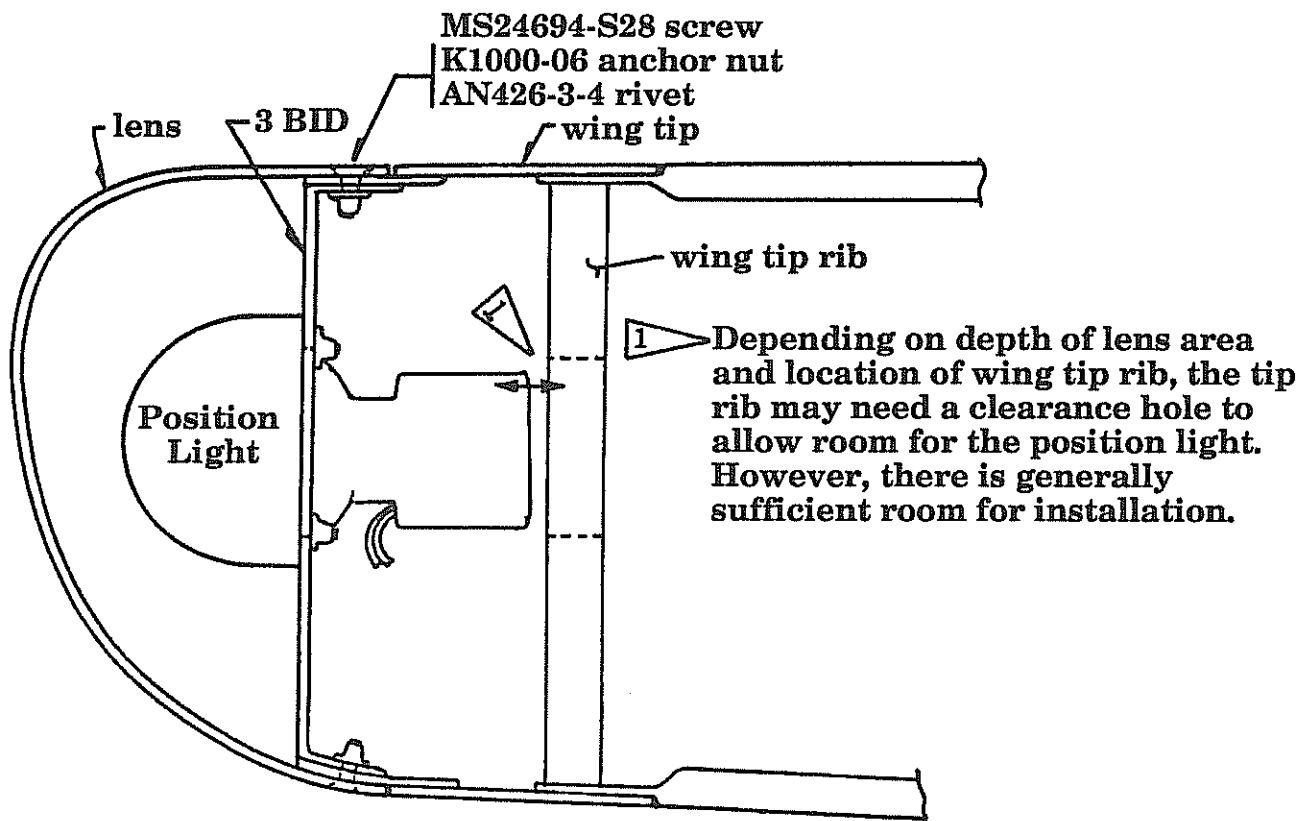

Method 1 - Strobe light installation

Use the Whelen A-625 strobe unit

- Remove the two screws and retainer ring and the lens from the strobe. Be very careful in handling the strobe unit since the tube assembly is delicate and expensive.

13. Per figure 9-28, use a rotary type tool and 1/8" ball end cutter to cut an oval through the tip. The lens can be used as a final sand to fit guide. Note that the lens should be mounted low enough to NOT be visible from the cockpit. Being able to see the strobe flash from the cockpit is blinding and totally unacceptable.
14. When the strobe lens fits properly through the tip from the inside, align and transfer the two attach screw holes. Run these attach screws through the tip to attach the unit.
15. You will now need a means to access this strobe unit for removal after the tip is bonded into position. To accomplish this, cut an inspection panel around the cutout for the strobe lens. Make it large enough to allow room to attach two machine screws, one in front and one in back.
16. Cover the back of the piece with plastic tape and insert it back into position (leave the strobe off). Use duct tape to hold it in flush alignment.
17. Now add a 3 BID tape around the inside to form a mounting flange. When cured, trim and attach the two mounting anchor nuts.

Wing tip strobe light

Cross sectional view

Figure 9-28

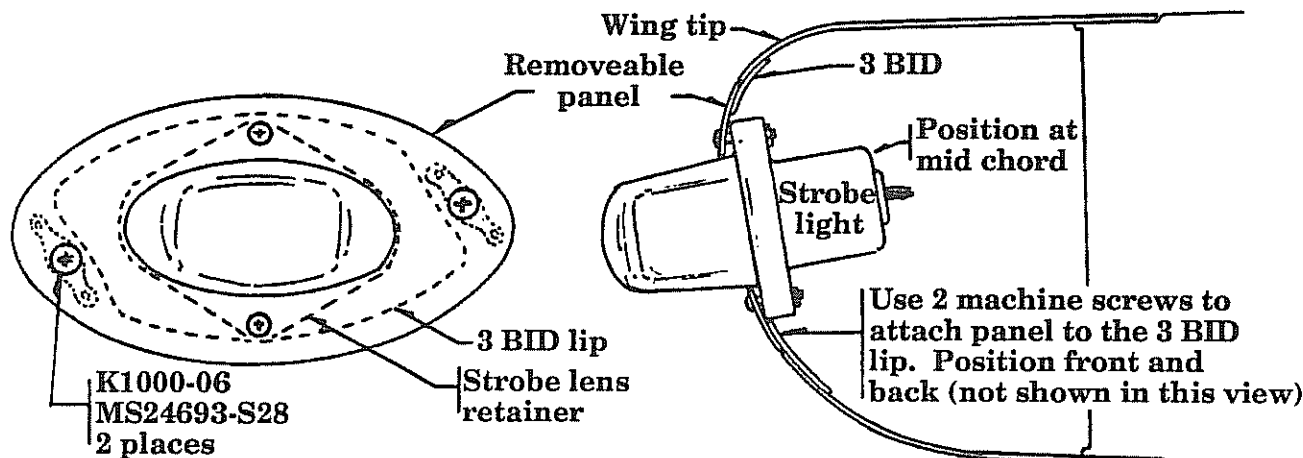

Method 2 - Requires only a through-hole for strobe

This method of closing out the clear lens position light area basically leaves the back panel removable thus allowing access into the wing tip so that the strobe can be serviced through the fwd position light hole.

17. Build the chordwise closeout panel in the fwd wing tp area as shown on figure 9-27. Leave the rear (spanwise) panel off.

18. Next trim and fit a removable panel to close out the aft spanwise area. Use .025" aluminum or similar. See figure 9-29.
19. This panel can simply be siliconed into position under the position light or it can be made with a flange large enough to allow the two rear screw mounts of the position light to pass through it thus securing it in position.

Wing tip light installation
Figure 9-29

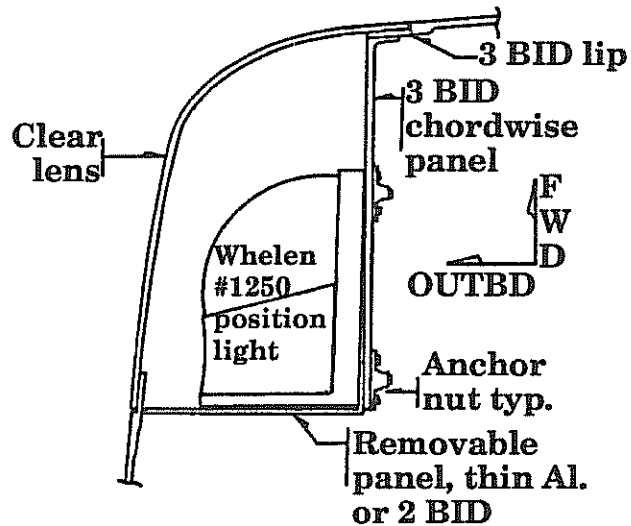

Method 2 - Strobe light installation

Use Whelen A-625 strobe unit.

20. As with Method 1, position and cut the access hole for the strobe lens (only) to stick through the tip, see figure 9-27 for basic reference.
21. Next, align and transfer the two attach screw holes and simply use these to attach the strobe, similarly as shown in figure 9-27 except the strobe will be serviced (removed) by reaching in through the fwd clear lens hole. This method eliminates the added complexity of the inspection panel for the strobe unit and is therefore highly recommended as a preferred installation process.



T. Tail light installation

This is a single tail light mounted into the rudder. There are two fairings which must be bonded to the rudder in order to fair and attach the position light unit.

1. Locate a position on the rudder approximately in line with the elevators. This is a good location for the light. Position the two fairings on the side of the rudder and mark their location.
2. Within the above fairing area at the rudder T.E. make a clearance cut with a rotary tool to allow the light housing to nest into the rudder. Cut only as much as is required for a fit.
3. Bond the fairings into position with either epoxy/flox or structural adhesive. Add 1 BID over the seam and fair it into the rudder with a small amount of micro. Also lay 1 BID across the aft face where the light unit will attach.
4. Drill a clearance hole through the aft face to allow the light unit to insert flush against that face.
5. Drill a through hole for the wires through the rudder L.E. and straight through the spar. This hole should be as close to centerline as possible. You'll have to drill around the lead counterweights that are on the rudder L.E. Use a long 3/16" drill bit. Drill a similar hole through the vertical spar web a couple of inches lower than where the hole is located on the rudder.

Use a long piece of stiff wire to string the two 18 gauge wires for the light.

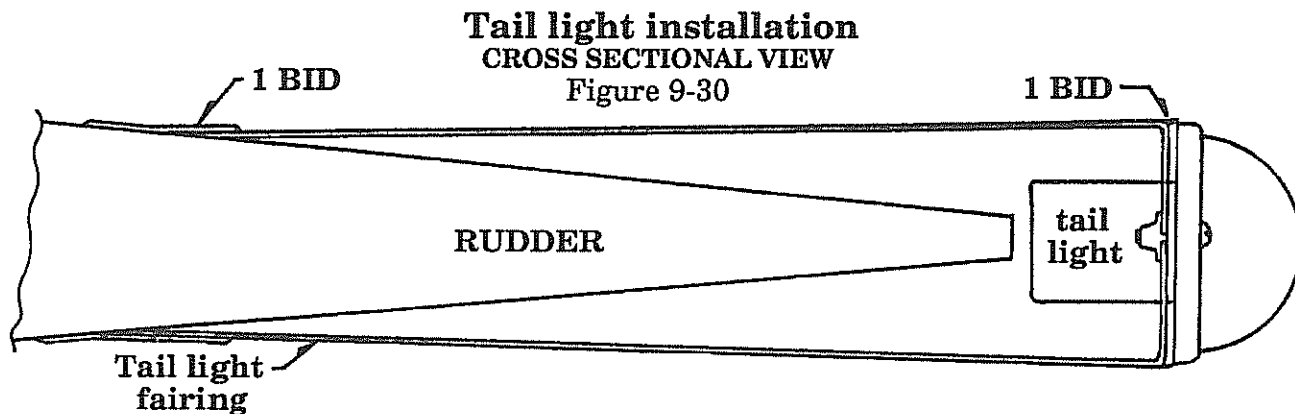

U. Wiring the lighting system

The Whelen lighting system uses the A413A, HDA, DF power supply for the strobe lights. This is a fairly large rectangular unit. It can be mounted vertically against the fwd face of the center main spar or in the baggage compartment behind the seat.

It requires shielded wires due to the high voltage traveling through the wires when firing the strobe lights. It should be carefully mounted so as to keep it well isolated from any possible fuel, oil, hydraulic fluid, etc. that might leak from line fittings.

The lighting wire system will be discussed in the electrical section of the plans. All wires can be run through the PVC tubing which was inserted into the fwd "D" section.



CHAPTER 10: AILERONS & FLAPS

REVISIONS

From time to time, revisions to this assembly manual may be deemed necessary. When such revisions are made, you should immediately replace all outdated pages with the revised pages. Discard the out dated pages. Note that on the lower right corner of each page is a "revision date". Initial printings will have the number "0" printed and the printing date. All subsequent revisions will have the revision number followed by the date of that revision. When such revisions are made, a "table of revisions" page will also be issued. This page (or pages) should be inserted in front of the opening page (this page) of each affected chapter. A new "table of revisions" page will accompany any revision made to a chapter.

Arrows

Most drawings will have arrows to show which direction the parts are facing, unless the drawing itself makes that very obvious. "A/C UP" refers to the direction that would be up if the part were installed in a plane sitting in the upright position. In most cases the part shown will be oriented in the same position as the part itself will be placed during that particular assembly step. However, time goes on and changes are made, so careful attention should be paid to the orientation arrows. That old cartoon of the guy agonizing over the plans for his canoe, built one end up, one end down, should not happen in real life. Especially to you.

CONTENTS

1. INTRODUCTION
2. DRAWING LIST
3. SPECIAL PARTS, TOOLS & SUPPLIES LIST
 - A. PARTS
 - B. TOOLS
 - C. MATERIALS & SUPPLIES
4. PROCEDURE
 - A. AILERONS
 - B. AILERON MASS BALANCING
 - C. AILERON TRAVEL LIMITS
 - D. FLAPS
 - E. FLAP BELLCRANK INSTALLATION
 - F. FLAP MOTOR INSTALLATION
 - G. RIGHT FLAP BELLCRANK ASSEMBLY
 - H. LEFT FLAP BELLCRANK ASSEMBLY
 - I. FLAP PUSHROD INSTALLATIONS AND ADJUSTMENTS
 - J. AILERON ROLL TRIM SERVO INSTALLATION (optional)

1. INTRODUCTION

With the outbd wing sections completed, the flap and aileron sections can be fitted.

The ailerons are two piece sections with the fwd web molded onto the upper aileron skin, they will require three ribs each. These ailerons will hinge from the top surface using two 6-1/2" hinge sections and must be 100% mass balanced.

The flap sections are also two piece. They do not have a web molded into them and require a simple spar near the fwd edge. Six ribs will be added and they will hinge from the bottom skin using three 10-1/2" sections. They do not require any mass balancing.

Aileron
Figure 10-1

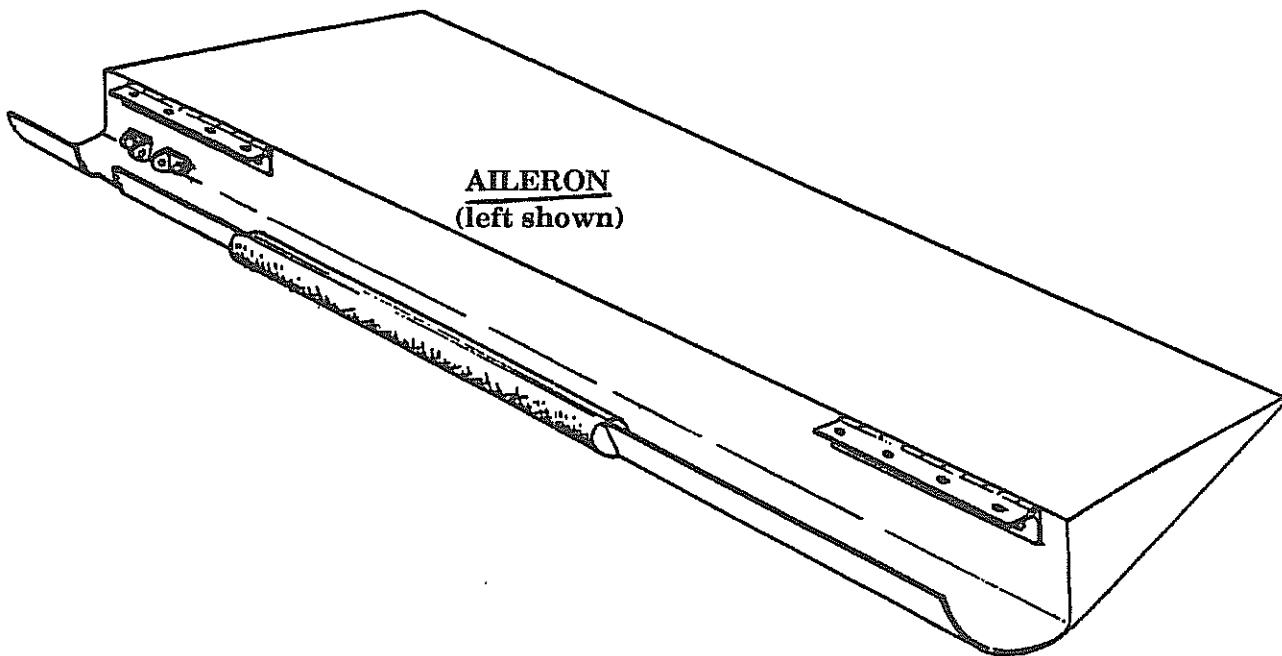

2. DRAWING LIST

Drawing	Page	Title
10-1	10-2	Aileron
10-2	10-8	Aileron control system
10-3	10-9	Assuring proper alignment of hinge sections
10-4	10-10	Aileron ribs
10-5	10-11	Aileron control horn attach
10-6	10-12	Aileron control horn cross sectional view
10-7	10-13	Aileron control horn brackets
10-8	10-15	Aileron mass balance installation
10-9	10-17	Aileron travel range
10-10	10-19	Flap assembly
10-11	10-20	Flap push rod installation
10-12	10-21	Flap movement range
10-13	10-22	Stiffening flap L.E.
10-14	10-23	Flap assembly breakdown drawing
10-15	10-31	Flap adjustment
10-16	10-33	Aileron trim servo

3. EQUIPMENT REQUIRED - SPECIAL PARTS, TOOLS & SUPPLIES

A. Parts

- 1 Airframe with outboard wing sections attached
- 1 AL-1 tubing
- 2 AL-2 tube
- 2 AL-3 tube
- 2 AL-4 tube
- 2 AL-5 idler arm
- 2 AL-6 phenolic
- 4 AL-7 bracket
- 2 AL-8 control horn
- 2 AL-9 bracket
- 10 AN3-10A bolt
- 4 AN4-13A bolt
- 8 AN3-5A bolt
- 4 AN3-6A bolt



B. Tools

- Dremel™ type rotary grinder
- drill motor
- drill bits:
 - #12
 - #30
- Straight edge, 6'
- Rivet squeezer



C. Materials & supplies

- epoxy
- flox
- BID cloth
- micro
-
-
-
-
-
-



4. PROCEDURE

A. Ailerons

1. Place the airframe in the inverted position with the outbd wing sections attached.
2. Refer back to page 9-9, fig. 9-2 for wing skin dimensions at the aileron locations. With the additional BID ply schedules added and the upper skin trimmed, the ailerons upper skins can be fitted into position.
3. Make up the aileron hinge sections, 4 required @ 6-1/2" long each.

NOTE: It is important to note that the hinge halves require a "reverse" fit from the assembled hinge as you receive them. Therefore, pull the hinge center pin before cutting the sections otherwise you'll waste two links when reversing them and reassembling.

4. Label each hinge section (i.e.: left outbd, left inbd, etc.)
5. Locate and drill (#30 bit) for the five (5) attach screws on each side of the hinge pc. Be sure to allow room on the end hole locations for the anchor nuts on the section that will attach to the wing.
6. Position the hinge sections on the wing at the proper aileron hinge locations and attach only the middle hole with one cleco. Do this to each hinge section. Note that the hinge sections should inset into the upper wing skin to within 1/16" maximum of being flush with the wing skin T.E. This will produce a nice fine gap line.
7. Next, to assure proper alignment of the hinge sections, place a straight edge (carpenter's level or equiv.) along the hinge edges which will cause the two pcs to align. With that alignment checked, drill for the remaining holes and set two clecos in each section. Refer to figure 10-3.
8. Position, trim and fit the upper aileron skins. Use a string along the T.E. to mark and set the T.E. of the upper aileron skin. Note that the aileron upper skin core material will extend fully to the T.E. of the aileron. Thus the aileron T.E. will be approximately 1/4" thick when finished.

Note: it is helpful to position a long straight edge from inbd flap T.E. position to outbd aileron T.E. position. Use vise-grips or small C-clamps to hold in position. This will provide a ledge onto which the upper aileron skin can be rested at the T.E. Be sure to position the straight edge such that it does in fact represent the upper skin T.E. (i.e., if you had a straight edge that was too long, it would run up the inbd fslg fillet and would not accurately represent the true surface for aileron and flap T.E.'s).

AILERON CONTROL SYSTEM
FIGURE 10-2

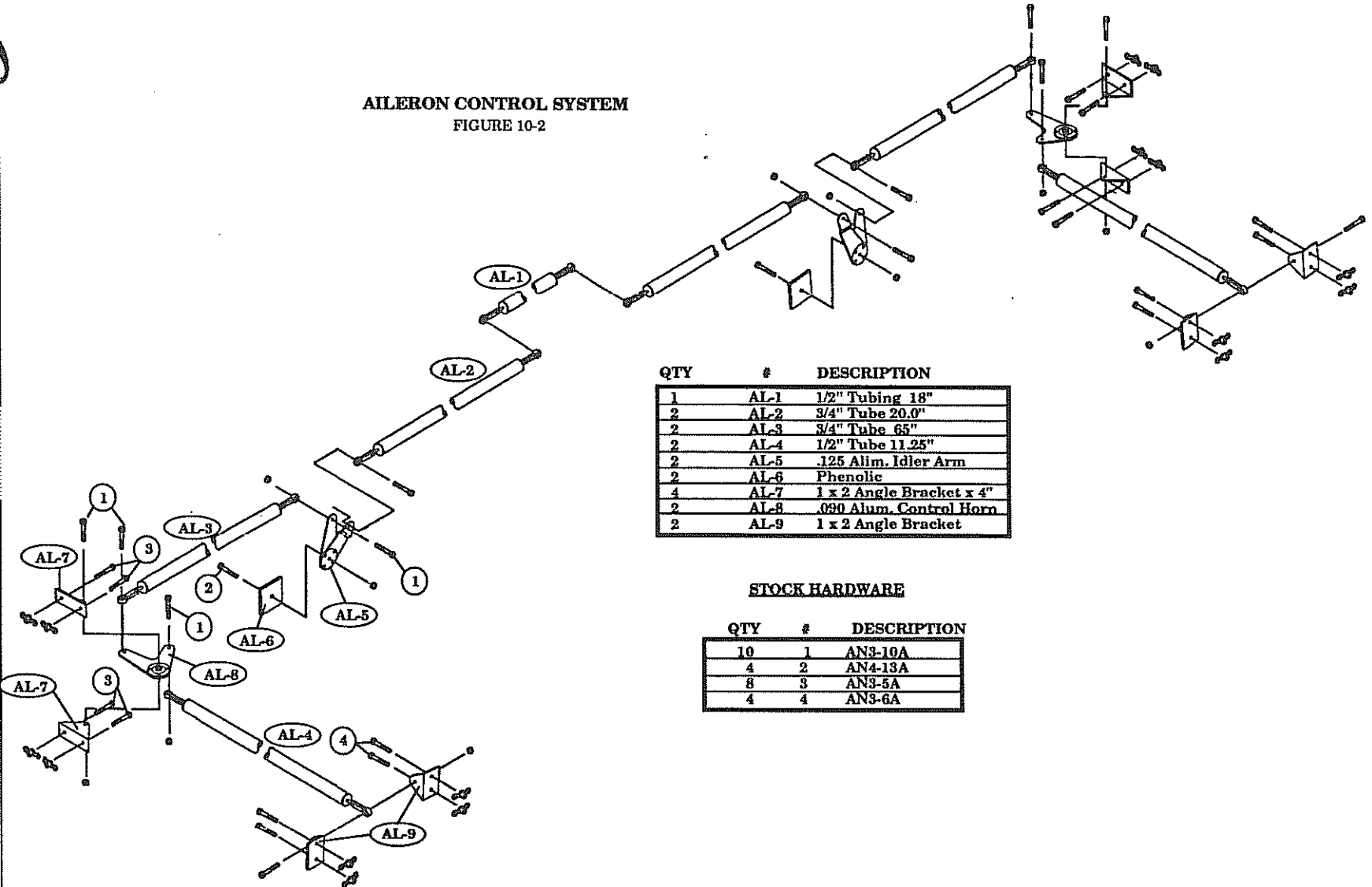

QTY	#	DESCRIPTION
1	AL-1	1/2" Tubing 18"
2	AL-2	3/4" Tube 20.0"
2	AL-3	3/4" Tube 65"
2	AL-4	1/2" Tube 11.25"
2	AL-5	.125 Alum. Idler Arm
2	AL-6	Phenolic
4	AL-7	1 x 2 Angle Bracket x 4"
2	AL-8	.080 Alum. Control Horn
2	AL-9	1 x 2 Angle Bracket

STOCK HARDWARE

QTY	#	DESCRIPTION
10	1	AN3-10A
4	2	AN4-13A
8	3	AN3-5A
4	4	AN3-6A

Assuring proper alignment of hinge sections

Figure 10-3

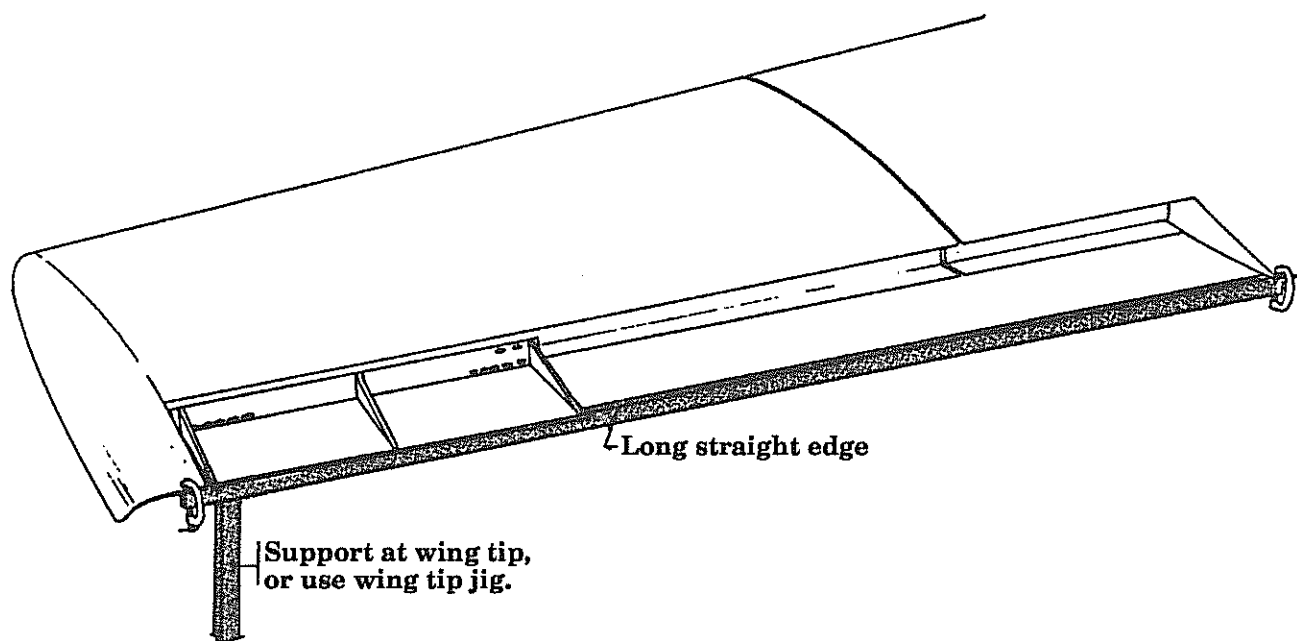

9. With the aileron skin trimmed to proper spanwise dimensions (T.E. dimensions and web dimensions are not critical at this time), place its T.E. on the straight edge and align with the upper wing skin so as to set the proper hinge attach locations. Reach underneath and run your hand along the juncture between upper wing skin T.E. and aileron. Verify that the transition is smooth. Adjust as required and set a clamp on the aileron hinge sections to secure them in this correct position.
10. Carefully drop the straight edge away thus allowing the aileron to swing downward exposing the hinge section. This will allow you room to drill for the cleco alignment holes through the hinge sections and through the aileron web. Set with one cleco per hinge section. Recheck the alignment by rotating the aileron up and down on the hinges.
11. At this time you can if you prefer, remove the hinge sections and attach the K1000-08 anchor nuts onto the hinge section which attach to the wing ski. Use AN426-3-5 rivets to attach these anchor nuts.
12. Reattach the hinge section.
13. Trim the web to size per cross sectional drawings on blueprint "E". Check your actual dimensions against these cross sectionals and make any adjustments necessary to effect the best fit should your dimensions vary slightly.

14. Fabricate three rib sections for each aileron. See figure 10-4, and blueprint "E". These three small rib sections can be sized from the cross sectional views on blueprint "E". They are fabricated out of 1/4" foam with 1 BID per side (or from 1/4" honeycomb with 1 BID per side).
15. Attach these ribs using micro and 1 BID. Inset the end ribs 3/8" to allow surface on the exterior for a 1 BID attachment as well.
16. Add 3 BID along the web at the hinge positions. Roll these 3 BID aft approximately 1/2" onto the upper aileron surface (on the inner side).

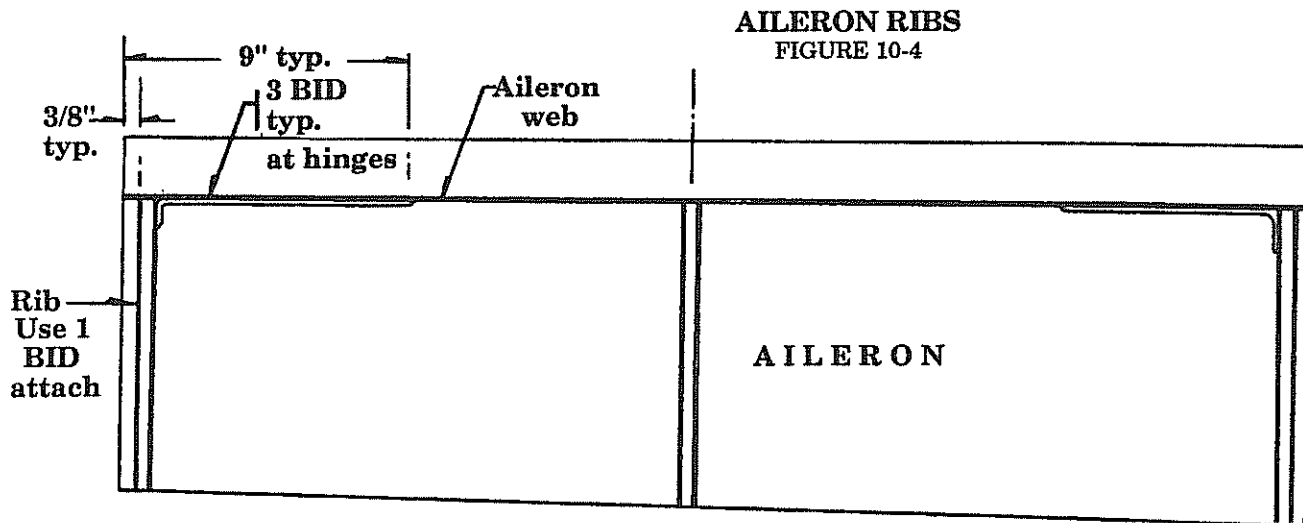

17. After the ribs have cured, fit the lower aileron skin into position per cross sectional views on blueprint "E". Swing the aileron up and down to check the alignment to the lower wing skin. By adjusting the aileron skin fwd or aft slightly, the gap uniformity can be established.

NOTE: The gap should be no more than 1/16". If there is any tendency for skin line deviations, the best fit will be when the aileron skin is either "in plane" with the lower wing skin or slightly thicker. The aileron should NOT be made thinner where it fairs to the lower wing skin.

The fwd, rolled surface of the lower aileron skin will require some trimming to achieve full down travel and full up travel, and should not expose the lower aileron skin L.E. Also note that the aileron lower skin is flat (the flap lower skin will have a cup shape in it).

18. Next make two aileron control horn attachments per figure 10-5. These will require one K1000-3 anchor nut on the inner side of the aileron web. See figure 10-6.

IF YOU PLAN TO INSTALL A COCKPIT CONTROLLABLE ROLL SERVO MOTOR, SEE SUPPLEMENTAL INSTALLATION BEFORE CLOSING OUT THE AILERONS, AT THE END OF THIS CHAPTER, BEGINNING ON PAGE 32.

AILERON CONTROL HORN ATTACH
(cut away view from top looking down, left aileron shown)
Figure 10-5

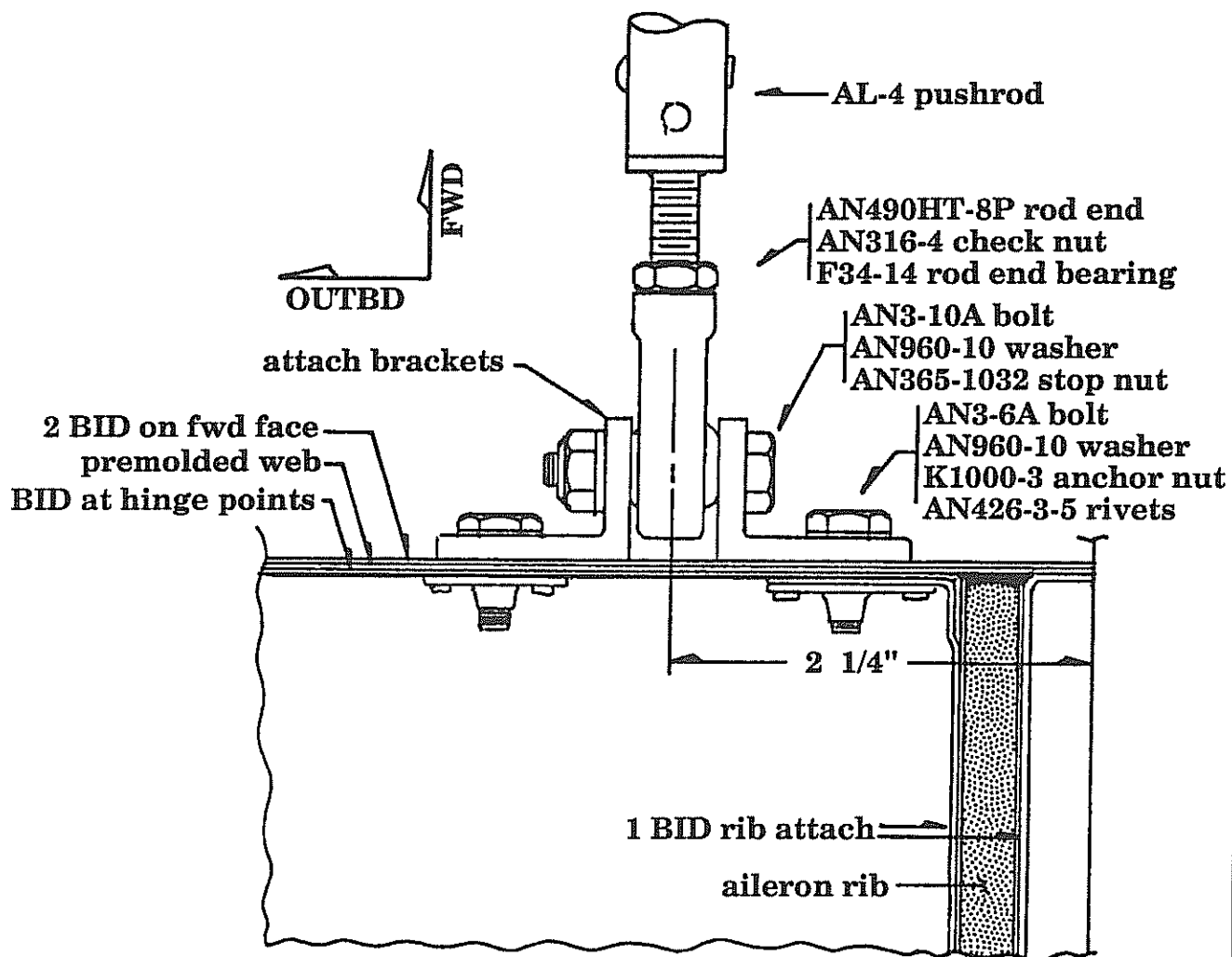

AILERON CONTROL HORN CROSS SECTIONAL VIEW

Figure 10-6

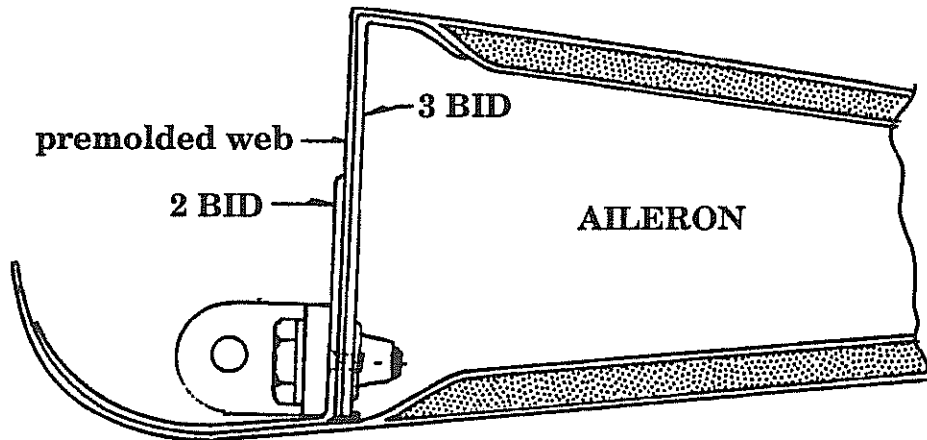

19. With the lower skin fitting well, it can be permanently bonded into position. Generally, due to the small size of the bonding areas, a good fit can be adequately established in advance. If there are any doubts about a good fit, then use the fit-release-bond approach used with the lower wing skin. If you are bonding using a one step procedure, use epoxy flox to bond the ribs to lower aileron skin. Use a small amount of structural adhesive with no more than 10% flox added to bond the T.E. Epoxy/flox can also be used on the T.E. Be sure that you achieve at least 1/4" - 3/8" contact along the T.E. This can be verified by placing a bright light under the part and viewing from above. The bond line contact will be easily visible.

Lightly clamp the aileron T.E. against the straight edge during cure. Apply light weight along the fwd portions of the aileron. Mixing sticks placed between wing skin and aileron L.E. roll work well in establishing a good gap clearance. Allow to cure.

20. After cure, remove and add the 2 BID attachment along the fwd face of the web where it meets the lower surface. Also add the 1 BID attach to the outbd surfaces of the end ribs.

AILERON CONTROL HORN BRACKETS
TWO REQUIRED PER SIDE
Figure 10-7

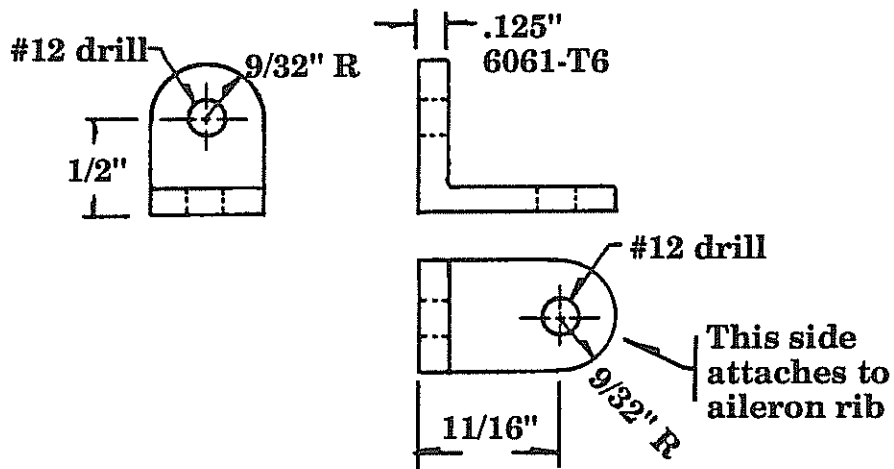

B. Aileron mass balancing

The ailerons must be 100% mass balanced. That is to mean that the ailerons must, when suspended from their hinge lines, hang in what is a faired position relative to the wing. That is NOT to mean that the top or bottom aileron skin will hang level as they will not hang level. Thus you will need a reference for the wing tip to verify that they do hang in a "faired in" position with the wing when the fslg is leveled.

1. The L.E. of the lower skin will be used to anchor the half-round lead weights used to generate the mass balance. Select the half-round weights, they weigh 15 oz. each and generally about 2-2.5 lbs. are required for each aileron.
2. Use hot glue or equiv. to temporarily attach the lead weights to the lower skin L.E., approximately mid-span on the aileron.
3. By holding the aileron by the hinge sections, check for a faired in condition as the aileron suspends on the hinges. Make sure that the hinges work freely for this check.
4. By adding or subtracting weight, a 100% mass balanced condition will result when the aileron T.E. hangs in proper alignment relative to the wing tip.

WARNING: It is acceptable to have a little additional lead weight, thus generating a T.E. UP condition. Primer and paint will add some weight to the aileron. Too little weight (i.e., T.E. DOWN) is unacceptable. If you generate a very slight T.E. up condition at this time (1/2", then you have plenty of excess balance weight to allow for the primer and paint.

5. Now, with the lead temporarily attached, check that there is sufficient clearance room in the wing for full aileron travel. If the lead interferes, adjust its position as necessary. It is also possible that the rolled lower L.E. of the aileron skin requires trimming. See figure 10-9, for aileron travel limits required.
6. Next add 2 BID over the lead weights to attach them permanently to the lower L.E. skin of the aileron, see figure 10-8. This will add a little extra fwd weight but the aileron will get slightly heavier when it is painted.
7. After the aileron is painted (thus completely finished) recheck for an in-line condition. If your finishing process added too much weight, you may have to add a small amount of additional lead. If so, simply add a small pc and wrap 2 BID over it BUT BE VERY CAREFUL to fully clean the bonding surfaces since paint and primer will likely have been on them.

AILERON MASS BALANCE INSTALLATION
Figure 10-8

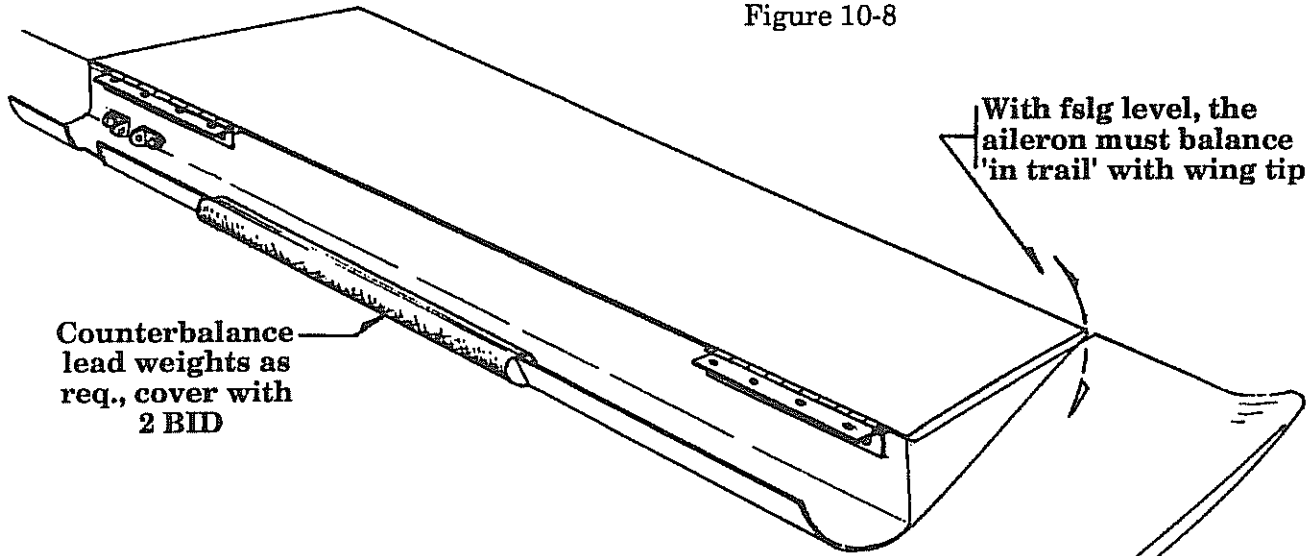

Counterbalance lead weights as req., cover with 2 BID

NOTE:
If room permits, this installation of the lead half-round bars is recommended. It will result in less lead weight being required to 100% mass balance

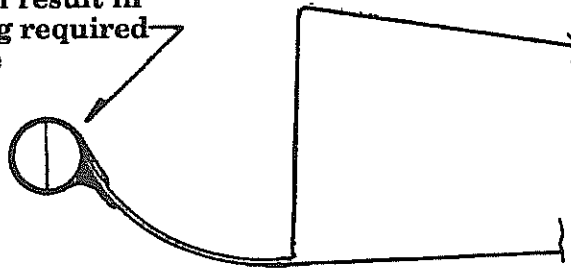

C. Aileron travel limits

The aileron travel limits can easily be established if you make sure that both left and right sides are identically set up. Otherwise, it will become a frustrating, back and forth exercise where one side won't go fully up (or down) because the other side has reached its limit stop thus preventing any further travel. If this should ever occur, it will be because the outbd bellcranks are out of alignment or possibly the inbd idler arms are out of alignment. Also, control horn pick up points on the ailerons themselves must obviously be the same distance from the hinge centers.

NOTE: This following procedure can be conducted at a later time when the plane is upright but for continuity it is described now.

1. With the plane upright, first center both control sticks and set the connecting pushrod to hold this alignment. This pushrod will be on the lower AFT side of the sticks.
2. Next set the aileron idler arms in a vertical alignment (i.e., the 1/4" pivot bolt is directly below a point equidistant between the two push rod attach holes). Connect the first aileron push rod from lower fwd side of stick, through cockpit closeout rib, to the idler arm. Set both sides but only connect one side. Leave the other side temporarily disconnected at the stick position.
3. Place the aileron bellcrank (in outbd wing) in a straight alignment with the main spar (i.e., the long arm on the bellcrank will be perpendicular to the spar web). Adjust and attach the second aileron push rod which spans from idler arm to this bellcrank. Be sure the control stick is still properly aligned (vertical) in the cockpit.
4. Next connect the 1/2" diameter push rod from short arm on bellcrank to the aileron control horns. Adjust so the aileron is in "trail". That's it.
5. Move the aileron up and down to check the travel ranges possible, see figure 10-9. Note that the lower skin L.E. will require clearancing for the push rod. Use a rotary tool to cut this clearance, keep the notch as small as possible. Check also that there is no rubbing anywhere in the system.

ANY RUBBING IS UNACCEPTABLE AND MUST BE CORRECTED BEFORE FLIGHT.

6. With one side working well, connect the other side in a like manner. Disconnect the first side to check for free movement on the second side.

7. When the second side is working well, connect the system together. Now recheck for travel ranges. If there is any "new" restrictions in the travel ranges available, it is due to one of the following (listed in the most likely order):
- The outboard bellcranks are not exactly symmetrical with each other (a small change makes a huge difference. Check first the alignment and secondly the adjustment of the push rod on the short arm when that aileron is in the down position. A slight adjustment there will allow a tremendous amount of additional travel to the other "up" aileron.
 - Idler arm orientation is off.
 - Distance between aileron control horns and their respective hinge lines is different from left to right. A small difference can be quite pronounced when measuring travel. If you have to adjust, it will require making two new control horn brackets for one side. If possible, maintain the side with the longest dimension and remake the short side.

AILERON TRAVEL RANGE
(cross sectional view, measure at aileron tip)
Figure 10-9

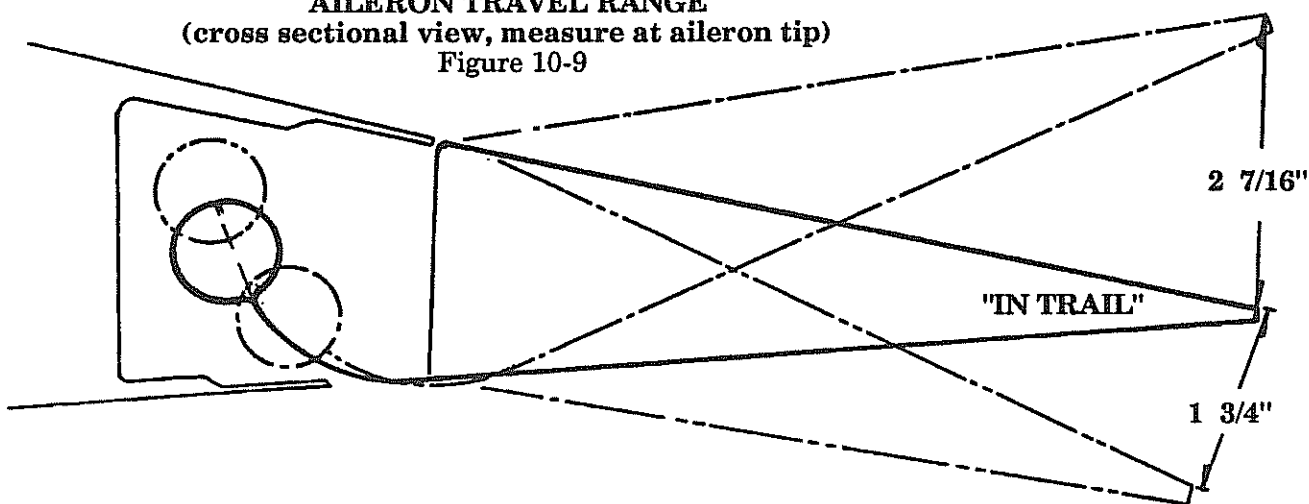

8. Finally, the ailerons, like all controls, must have positive limit stops. There are two provisions for this on the Lancair. The control sticks are such that they hit a limit stop created by the yoke on the crossover weldment. This generally works out well. Also, there is a small angled piece on each side of the crossover weldment which has a $\frac{1}{4}''$ hole in it. This is designed to hold a $\frac{1}{4}''$ bolt which can be adjusted to form a limit stop by its contact against the side of the control stick. Lock the adjustment by setting a check nut on both sides of the tab and tightening down against the tab.

D. FLAPS

The flaps are built in a somewhat similar manner as that used for the ailerons but with some obvious differences. Flaps are hinged from the bottom surface and will require six ribs plus a fwd spar. They are push rod actuated from the inbd end.

NOTE: The flap halves bond together at the T.E. in a different manner than other surfaces. You'll note a 1" joggle on the lower flap skin T.E. The aft edge of this joggle is the flap T.E. Trim to that line to establish the L.E. trim line. See blueprint "J" which illustrates how the T.E. bonds together. After completion, fill the joggle in the bottom T.E. with micro.

1. The fslg should be on the upright position with the wings attached. A level condition is not important.
2. See page 9-48, figure 9-23 for flap dimensions.
Blueprint "B" for flap rib patterns.
Blueprints "I" and "J" for flap linkage.
3. Trim and fit the lower flap skin.
4. Cut and fit all flap hinge sections to the wing first. These are 10.5" sections. These hinge halves will not be reversed.
5. In a manner similar to the aileron hinge installation, drill and set either one of the center holes first in each hinge section. Note that flap hinges require six (6) attach screws per hinge section. Align with a long straight edge and drill for the remaining holes. Attach the K1000-08 anchor nuts and machine screws.
7. With the long straight edge under the flap T.E., lay the lower flap down onto this straight edge and fit the fwd spar per figure 10-10. This spar is made of 1/4" foam with 1 BID per side or 1/4" honeycomb with 1 BID per side. Note that the inbd section requires a 1/4" phenolic insert into the web to pick up the flap control horn brackets, see blueprint "J". Use micro to bond the spar in position on the lower flap skin and allow to cure.
8. After cure add 2 BID to the aft face and roll 3/4" down onto the flap skin. Allow to cure.
9. Remove the flap and add 3 BID along the fwd face of the web and roll fully off the L.E. of the skin. At this same time, add 7 BID additional where the hinge sections attach.
10. Now reattach the flap and again rest it on the straight edge at the flap T.E.

11. Fit the six ribs. These are 1/4" foam with 1 BID per side or 1/4" honeycomb with 1 BID per side. Attach with 1 BID tapes on each side and allow to cure.

FLAP ASSEMBLY
(lower skin installation)
Figure 10-10

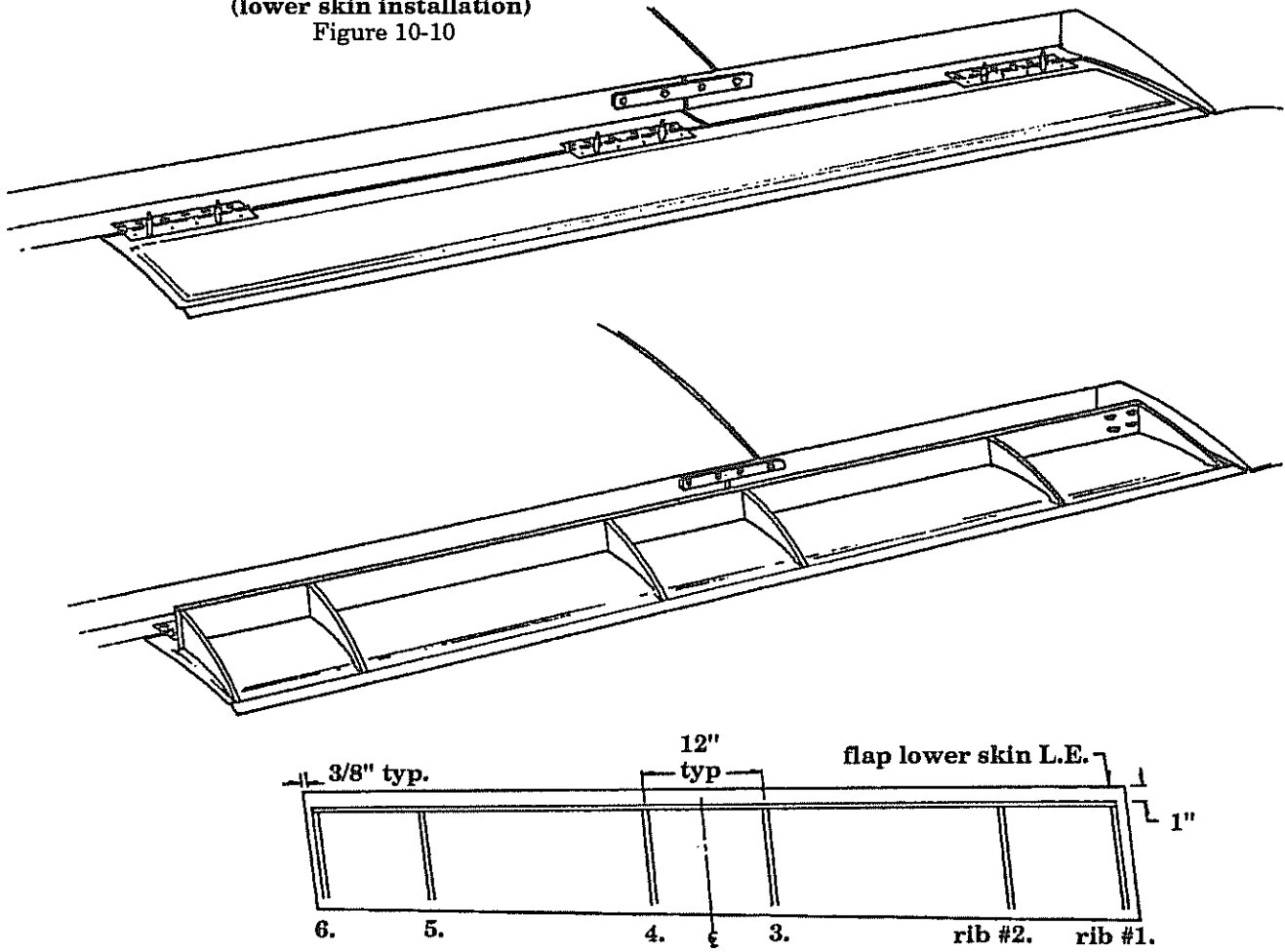

12. Next fit the upper skin into position. Locate the roll of the L.E. per cross sectional views on blueprints "I" and "J". Hold in relative position (a second set of hands will be helpful here) and rotate the flap up and down to check the gap alignment. The flap should have a travel range from 5/8" T.E. UP (from faired in position at inbd fillet) to full down. See figure 10-12. The gap clearance is only important in the upper most travel ranges since that is where cruise will be. As the flap drops down for landing, we really don't care if things start to get a little "dirty" since that's what we are desiring anyway when landing.

Trim the upper skin L.E. as required to allow clearance room when the flap is up. Adjust the vertical height of the spar and ribs to achieve a nice smooth faired in alignment with the upper wing T.E. The gap should not be more than 1/16".

FLAP PUSH ROD INSTALLATION
(cut away view from top looking down on left inbd flap)
Figure 10-11

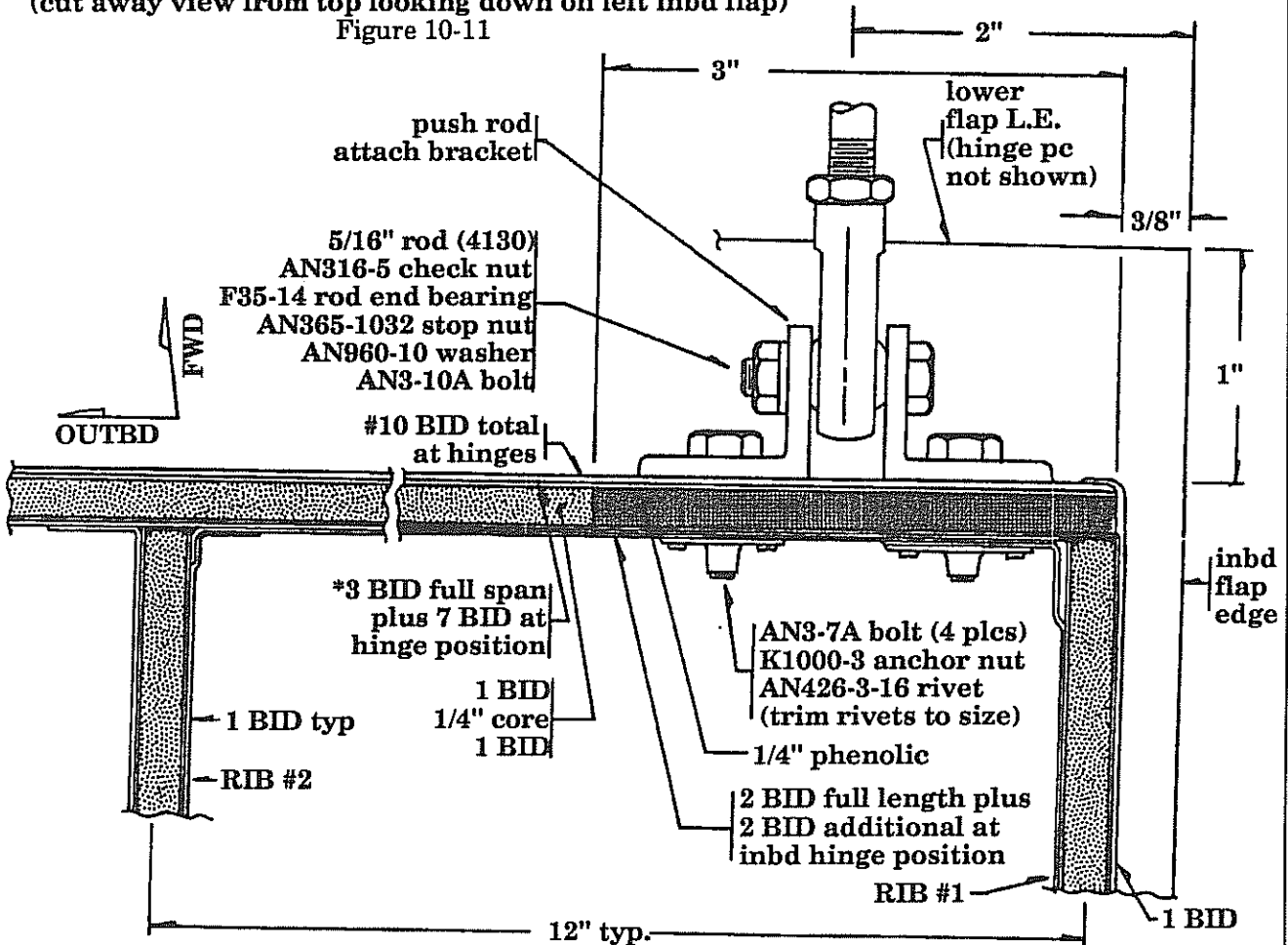

13. When the fit is correct, you're ready to permanently bond the top skin on.
14. Drill for the attach bolts which anchor the push rod brackets. These should be installed with K1000-3 anchor nuts.

FLAP MOVEMENT RANGE
Figure 10-12

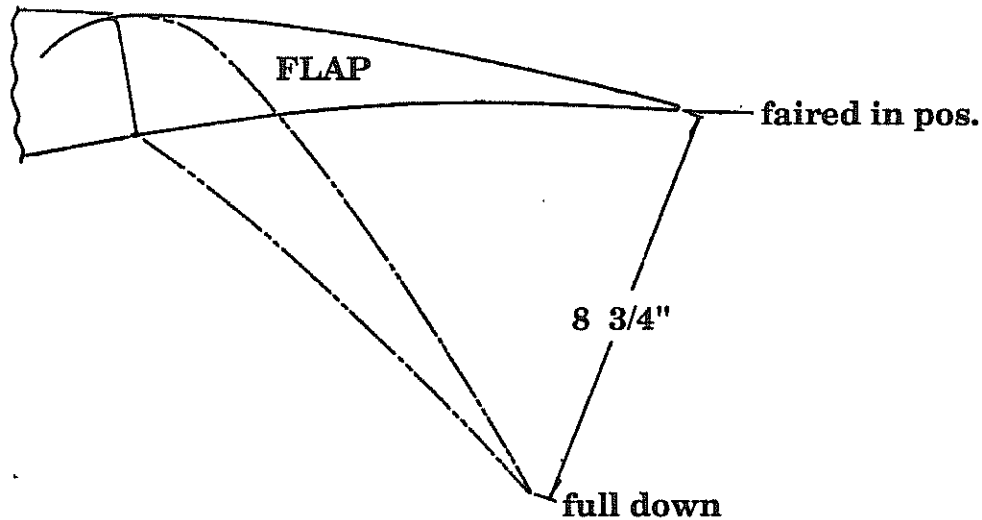

15. Bond the upper skin in position, use epoxy/flox along all joints (structural adhesive can be used along the T.E. joint). Use light clamping pressure on the T.E. to set the gap.
16. Check the flap travel for clearance freedom. There should be no rubbing or interference.

NOTE: Make a special note to check the aileron through full travel ranges with the flap in all positions, there must be no contact between the two.

WARNING: Adequate clearances must be established and sufficient stiffness established such that the flaps upper rolled L.E., when fully deployed, will not have a tendency to flex upward and snag on the upper wing skin T.E. Such a condition could jam the flap and thus not allow retraction of the flap. This could be dangerous on an aborted landing and subsequent "go-around". Check this closely.

17. If the above warning condition exists, a little extra roll can be induced into the extreme FWD section of that roll. Note any amount of added roll desired and remove the flap from the wing.

18. The juncture between upper rolled skin and spar web requires a 2 BID layup. When applying this layup, a slight roll increase can be set in if it is desired. To do this, clamp the flap down securely (without crushing any surfaces) and immediately after the layup is made, apply pressure to induce the desired additional roll. Hold in position until cured. Post cure with a heat gun.
19. With full flap down travel, the fwd L.E. of the upper skin will often just start to open up (i.e., the upper flap L.E. will not remain tucked into the wing skin). If this condition exists with full flap down, then the upper leading edge must be stiffened. The ends are of most concern. This stiffening is an easy procedure.

Stiffening flap L.E.

Figure 10-13

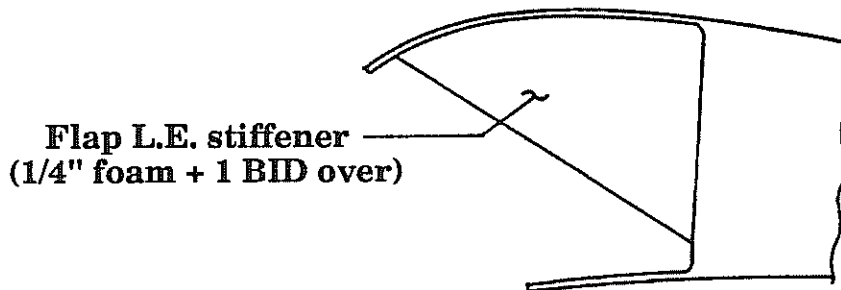

- a. From some 1/4" foam, make several small wedge like pieces to fit between flap spar web and fwd into the rolled L.E. Micro these pcs into position, placing one approximately every 12". Set the end pcs inbd by 3/4". Do not place any stiffeners directly in line with the hinge sections.
- b. Next lay a 1 BID ply over them in a "draping" like manner. Contact 1/2" minimum onto the flap all around the pcs. This will sufficiently stiffen the rolled L.E.



Quantity #	Description
1	FL1 Electric flap motor
1	FL2 Flap motor micro switch assembly
1	FL3 Flap motor bellcrank (steel)
2	FL4 Flap bellcranks (steel)
4	FL5 Flap bellcrank brackets (Al. angle)
1	FL6 Flap motor bracket (Al. U-channel)
2	FL7 Flap motor bellcrank brackets (Al. angle)
1	FL8 Spar backup plate (.090" Al.)
1	FL9 L flap pushrod tube (3/4" x .035")
1	FL10 R flap pushrod tube (3/4" x .035")
2	FL11 Flap actuating rod (5/16" steel rod)
2	FL12 Flap connecting bracket (Al. angle, rt. pattern)
2	FL13 Flap connecting bracket (Al. angle, left pattern)

FLAP ASSEMBLY BREAKDOWN DRAWING

FOR MODEL 320

Figure 10-14

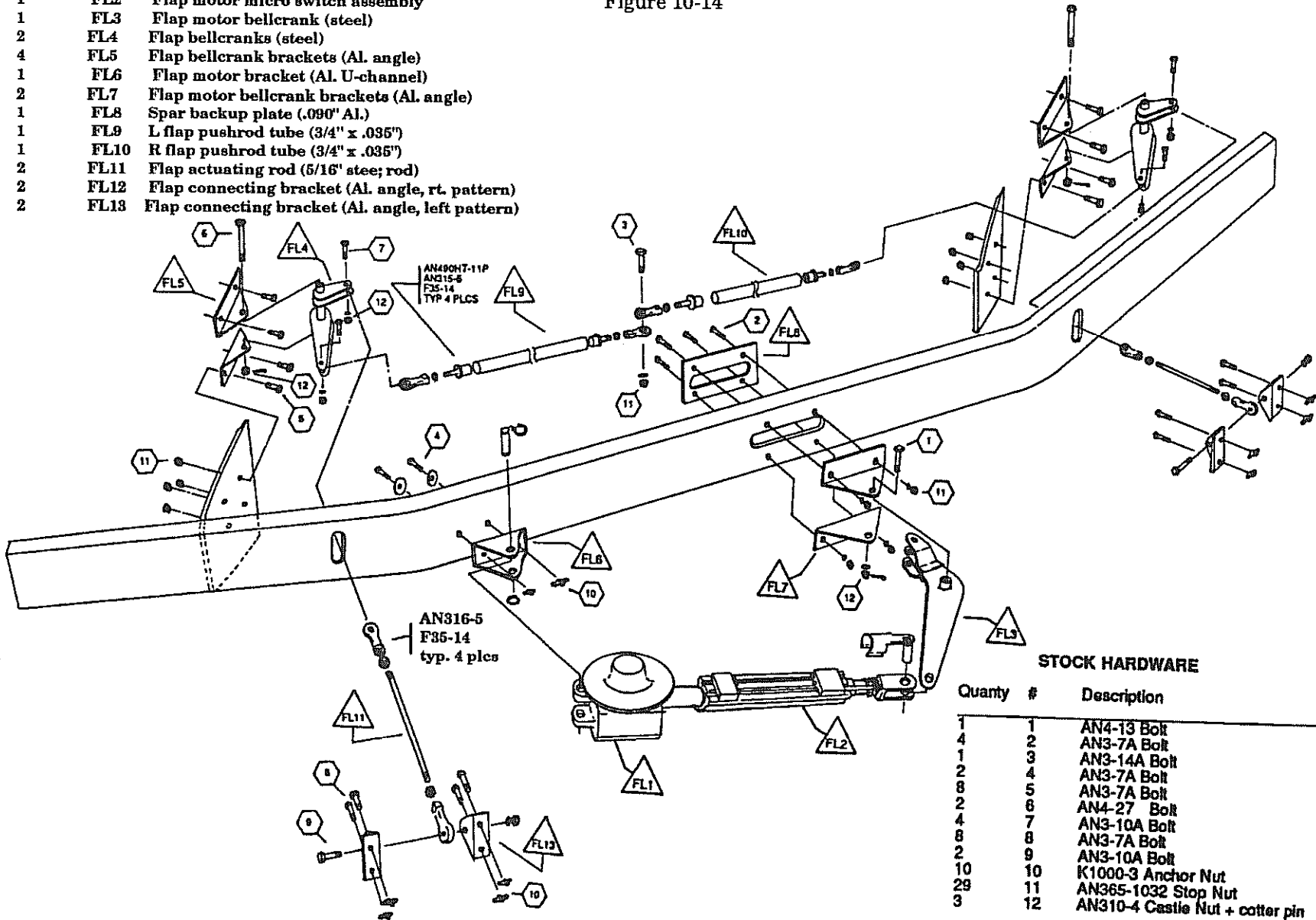

STOCK HARDWARE		
Quantity	#	Description
1	1	AN4-13 Bolt
4	2	AN3-7A Bolt
1	3	AN3-14A Bolt
2	4	AN3-7A Bolt
8	5	AN3-7A Bolt
2	6	AN4-27 Bolt
4	7	AN3-10A Bolt
8	8	AN3-7A Bolt
2	9	AN3-10A Bolt
10	10	K1000-3 Anchor Nut
29	11	AN365-1032 Stop Nut
3	12	AN310-4 Castle Nut + cotter pin



Flap bellcrank assembly into fslg and stub wing

For systems uniformity purposes, this procedure is described here however, it should be performed prior to installing the stub wing skins. Refer back to the beginning of Chapter 6, page 6-2.

Lancair flaps are full electric actuated. They are designed to run from +45° down to -10° up (reflex). Note that the "faired in position" for flaps and ailerons on the plane is actually a -7° reflex position. This is unique to the model 320 Lancair. Flap position checks are by visual means (look out the window).

The flap bellcrank installation consists of three basic sections:

- a. Flap motor installation with flap motor control horn in fslg ctr,
- b. Left flap bellcrank installation in left stub wing,
- c. Right flap bellcrank in right stub wing.

E. Flap motor bellcrank installation

1. Locate center line on aft center spar. It will have a depression in the fwd face of the spar web where the core material is deleted and a web prepreg build up has been pre-installed. Locate center both vertically and spanwise.
2. Measure 1-7/16" (spanwise) from ctr in both left and right directions. Mark and drill a 5/8" diameter hole.
3. Using a sabre saw, cut out the remaining slot by cutting along a line connecting the top of the two holes and the bottom of the two holes. See blueprint "I". You will end up with a through hole measuring 3-1/2" x 3/4".

NOTE: Since the flap motor bellcrank pivot center measures 3/4" high, you'll need the slot in the aft spar web to be that same 3/4" high in order to get the bellcrank through it and in position. If you have the hardware bracket kit, a slight notch will have to be filed through the backup plate in order to pass the bellcrank since the backup plate is made with a 5/8" wide slot. If you are making your own brackets, you may also choose to follow this format since it allows for a slightly easier alignment vertically for this assembly.

4. Make a plate per blueprint "I" which measures 3-3/4" x 2-3/8" that has the above cut out through its center but do not yet drill the attach bolt holes. This plate will be used as a backup for the attach bolts and will mount on the fwd face of the web.
5. Make the two identical flap motor bellcrank attach brackets out of 1" x 2" angle aluminum, see blueprint "I".

6. Assemble the flap motor bellcrank onto its two attach brackets. Check rotation for free, unobstructed travel.
 - The correct travel range allows the fwd facing short arms to swing 1-3/8" each way from center. See blueprint "J".
7. Position the assembly on the aft face of the spar web in proper alignment with the slot in the web. Mark one of the holes and drill through the spar web.
8. Place a bolt through to hold the assembly in position and drill for the remaining holes.
9. With the holes all drilled, position the flap backup plate on the fwd face of the web and transfer the hole locations. Drill those holes through the backup plate.
10. Paint or anodize the aluminum pcs and install permanently using AN3-7A bolts with AN365-1032 stop nuts.

Be sure to orientate the flap motor bellcrank properly. When viewed from the top with the fwd section aligned down centerline, the aft (long) arm will be to the left (pilot) side.

The flap motor bellcrank can be installed per blueprint "I", also see blueprint "J".



F. Flap motor installation

The flap motor is mounted on the left side using a piece of U channel aluminum. It is attached to the aft face of the aft spar web. See blueprint "J".

1. Locate BL 18.25 on the left side of the aft ctr spar. Locate the vertical centerline as well.
2. Make the flap motor attach bracket out of a piece of U-channel. See blueprint "J".
3. To achieve a nice snug fit of the flap motor attach pin through the bracket, drill a 3/8" hole and use a rat tail file to open it up to .400", this will require removing .012" all around the diameter.
4. Drill the two attach bolt holes through the U-channel.
5. Assemble the motor onto the bracket and position this unit into the fslg against the aft spar web, attach the clevis pin to the flap motor bellcrank. Now check for a good alignment so that the clevis does not bind on the bellcrank. Mark that resultant position of the motor attach bracket on the spar web.
6. Position the bracket along the vertical ctr line marked at BL 18.25 and drill through the web for the two attach holes. Attach two K1000-3 anchor nuts to the inside of the U-channel and attach it to the web with two AN3-7A bolts. Use large area washers on the fwd face of the web.
8. Connect the flap motor to the motor bellcrank with the clevis pin. This clevis pin must be inserted from the top. It has a locking clip on the side which also must be snapped over the shaft of the motor.



G. Right flap bellcrank assembly

The left and right flap bellcrank assemblies have identical bellcranks but totally different installations. One side can not be installed to match or even be a mirror image of the other.

The right side bellcrank will attach using a small rib-like bulkhead which angles off from the right cockpit closeout rib.

1. See blueprint "J" for the rib-like bulkhead template. Make a paper or cardboard pattern of this template first and check it for a good fit into your stub wing section since small variations are common. This rib can be made out of 1/4" foam (or honeycomb).

NOTE: it is important to set this rib such that it has an approximately 3° - 4° aft lean. This will help for alignment with the flap actuating rod.

2. With the rib pattern fitting snug, remove the core material and replace it with the phenolic (1/4"). See template pattern on blueprint.
3. This bulkhead will require 8 BID per side (it has to be stiff). It is easiest to apply the 8 BID to the bulkhead before it is installed. (The attaching BID ply schedule is less.) This will allow you to position and drill the four bolt holes before permanently installing the bulkhead. It would be difficult to align and drill these holes once the bulkhead was permanently installed.

So, apply the 8 BID to each side (note the type of core closeout used, this is required for strength). After cure, position the bulkhead and clamp the bellcrank/bracket assembly into position on it. Check for clearance of bellcrank to spar web through full rotation. When the position is good, remove the assembly and drill for the 4 bolt holes which will hold the brackets to the bulkhead.

NOTE: The 63° angularity between a fwd / aft reference line on the airplane and the bulkhead is VERY IMPORTANT. Without this, proper flap travel may not be possible. You can set this by making a simple wedge of cardboard which represents this angle as traced off blueprint "I". Also note that if you are using your cockpit closeout rib as a reference, it must have been installed along a true fwd / aft axis line. If it is off, adjust accordingly to achieve the required 63° from fslg centerline axis.

Be sure to mark the location of the bulkhead onto the lower skin so you can get back to it later. Be sure to mark the brackets (left top, left bottom) for later reference in case the assembly is taken apart.

4. Next bond the bulkhead back into permanent position using epoxy/flox. It may be easiest to allow this to cure before adding the attach BID tapes.
5. Add the 4 BID attach tapes. They should contact 3/4" onto the bulkhead and 1" onto the mating surfaces of stub wing / closeout rib and spar. Allow to cure.

6. Per blueprint "I", also see page 4-20, figure 4-12, cut the cockpit closeout rib through-hole for the FL-10 push rod (see flap breakdown drawing 10-14, page 10-23). The edges must be closed out with micro after you've checked for a no-interference passage of the 3/4" push rod.

NOTE: The cockpit closeout holes are not the same size. See page 4-20, figure 4-12 for dimension differences from left to right.

7. Per blueprint "I", also cut a through hole through the aft spar web.

WARNING: This through hole must go through the portion of the spar web which is solid glass to glass. This area is easily visible from the fwd face of the web. The 5/16" steel actuating rod which will pass through this hole should align approximately 2" outbd of the inner edge of the flap. Use the fslg fillet as a guide. For the time being, simply cut a small hole (1/2" dia.) through and enlarge as required when checking for flap travel. Use a rotary tool and 1/8" carbide cutter. **KEEP THIS THROUGH HOLE AS SMALL AS POSSIBLE.** It should not exceed 5/8" across and 1" in height.



H. Left flap bellcrank assembly

The left side is similar except the rib-like bulkhead is entirely different. Also the closeout rib through hole position is slightly different.

1. From blueprint "J", trace onto cardboard a copy of the bulkhead and fit it into the stub wing section of the fslg at BL 31.5. This bulkhead will be positioned true vertical about the bellcrank assembly will be mounted such to be leaning aft by 3° - 4° . Again, this is important for the best alignment with the flap.
2. Next make the bulkhead from 1/4" foam or honeycomb with the 1/4" phenolic insert and 8 BID per side. Be sure to make the bracket mounting side flat thus inserting the phenolic from the opposite side. Allow to cure.
3. Position the bellcrank assembly with attach brackets onto the bulkhead and position the assembly into the stub wing. Establish the 63° orientation of the bulkhead as referenced to the aft spar. Check for clearance at the aft spar web (the clearance should not be more than 1/4". Otherwise the 3/4" push rod (FL-9) would be too far fwd into the seating area as it passes through the cockpit. Lean the bellcrank assembly aft to the 3° - 4° position and clamp to the bulkhead. With the fit checked as OK, carefully mark the location of the bulkhead onto the skin and remove the assembly.
4. Drill for the 4 bracket attach bolts.
5. Now permanently bond the bulkhead in with epoxy/flox and allow to cure.
6. Add 4 BID attach tapes around all perimeters contacting 3/4" onto the bulkhead and 1" onto the adjacent surfaces. Tapes must be applied to both sides of the bulkhead.
7. Cut the through holes in cockpit closeout rib and through the aft spar web. Be sure that the web is solid glass to glass and reference the fslg fillet for the through hole, see blueprint "J" and page 4-20 figure 4-12.

I. Flap push rod installations and adjustments

There are two 3/4" push rods which travel just in front of the aft spar fwd web face. They attach to the flap motor bellcrank (the portion that protrudes fwd through the web into the cockpit area). These push rods then attach to the long arms on the FL-4 bellcranks in the stub wing section. The short arms will attach the (FL-11) 5/16" solid steel actuation rods that link directly to the flaps.

The alignment of these bellcranks is quite critical for uniform travel of each flap relative to the other. If alignment is off, one flap will move at a faster rate than the other which is obviously not acceptable.

1. Set the flap motor bellcrank such that it is 1" to the right (passenger side) of center, the motor will be nearly fully retracted. This is a good position to start with for the flap "neutral" or "in trail" condition. See figure 10-15.
2. Position the FL-4 flap bellcranks (in the stub wing) in a uniformly square manner per blueprints "I" and "J". The pushrods should now be set to these resultant dimensions.
3. Cut the 3/4" x .035" aluminum rods to length and set the AN490HT-11P rod ends with two AN470AD-4 rivets. You must "peen" these rivets, DO NOT USE A RIVET SQUEEZER. This is, by the way, typical of all push rod tube riveting on the Lancair.
4. Install the push rods and adjust the F35-14 rod end bearings as required. Lock them in final position with the AN316-5 check nuts. Mark the tubes for left and right.
5. Check the clearances where the push rods transition through the closeout ribs. Adjust if necessary and use micro to close out the rib holes.
6. Assemble the flap actuating rods with the F35-14 rod end bearings and the AN316-5 check nuts. Attach the flap and attach the actuating rod to the flap first. Then, from the gear well, reach up and set the bolt to attach the actuating rod to the FL-4 flap bellcrank.

Flap adjustment
(shown for the neutral position)
Figure 10-15

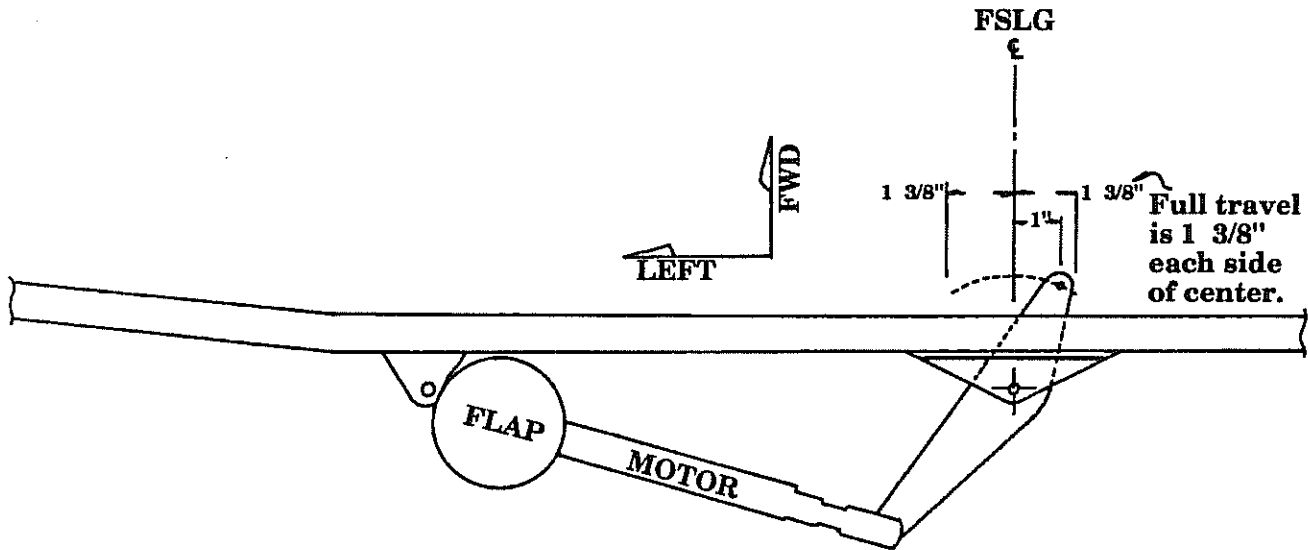

- Set for the neutral position. Then run the flaps to the full down position (measured as 8-3/4" from the fillet T.E. to flap inbd tip). The motor does not have to be connected to perform this adjustment.

Measure both flaps in the down position, they should measure the same. If they do not, then there is some degree of difference in the relative alignment between the FL-4 flap bellcranks. Adjust them until flap throws are identical. Then set the check nuts on all push rods and actuating rods. Mark the actuating rods as left and right.

WARNING: During this adjustment and any other adjustment, the minimum amount of threads allowed in the rod end bearings is equal to the diameter of the thread shaft (i.e., a 5/16" shaft must penetrate 5/16" into the bearing body). Some bearings will have a small hole drilled into the shank of the bearing near the open threaded end. This is to check for thread penetration. If you can stick a fine wire through this hole all the way to the other side, then there are not enough threads inserted and an adjustment must be made such to achieve greater thread penetration or a longer shaft is required.

If this should ever occur, check to see if you can back the other end of the shaft out of the bearing at all, this may save you from having to make another, longer push rod.

Final small adjustments are often required after initial flight testing results.

J. Aileron roll trim servo installation (optional)

It is a very good idea to install an aileron trim control servo in your Lancair. The common approach is to simply attach a fixed trim tab and while that's not too bad, it just can't handle all the trim needs (i.e., if you rig your plane to fly hands-off solo, put a passenger in the right seat and he or she will establish a respectable right rolling moment). And of course, fuel is the other big variable. So if you want to be able to balance out the roll mode, perfectly, all the time, you'll need a servo that is controllable from the cockpit. Even if you have an auto pilot, it won't always be engaged, and also it is a bad idea to have to rely on the autopilot system for roll trim all the time. What follows here is a nice installation similar to that we've made on several 235's and 320's (the installation is the same). We use (and stock) the MAC S4 servo kits, a complete set with servo, control rod assembly, control rocker switch and an LED light unit that indicates the two travel limits and the middle point (the limit LED is virtually useless since we never travel to the limit stops however, the middle point could, with a bit of trial and error, be set up to indicate a basic takeoff position. The "look out the window" approach works very well and even if you were way off, the stick loads are easily managed until proper roll trim can be driven in. The kit is the same price with or without the LED, so you'll get that LED whether you use it or not.

Refer to figure 10-16. The inspection door is used as the mounting plate for the servo, making it a very clean and easy installation. We used an 8" tab on the T.E. of our company plane, and found it to be a "hair trigger". About a 5-1/2" tab should be just about right.

The servo can now be installed by attaching the clevis rod to the servo, and sliding the rod into the aileron first, guide it to and out through the slot to the tab. Screw the inspection plate into place, install the clevis pin in the clevis/tab, cotter pin it, and you're done. Removal is accomplished by reversing the order - removing the clevis rod from the tab, removing the screws from the inspection plate and removing the inspection plate with the servo attached. Pretty neat, huh?

You will need a bit more balance weight to offset the installation, but it is a relatively light system, so the weight penalty is quite minimal.

As a final note, we do recommend that the tab be positioned on the left side simply for improved visual inspection purposes.



10-32

Chapter 10

REV. 0 / 11-1-91

AILERONS & FLAPS



AILERON TRIM SERVO

Figure 10-16
BOTTOM VIEW

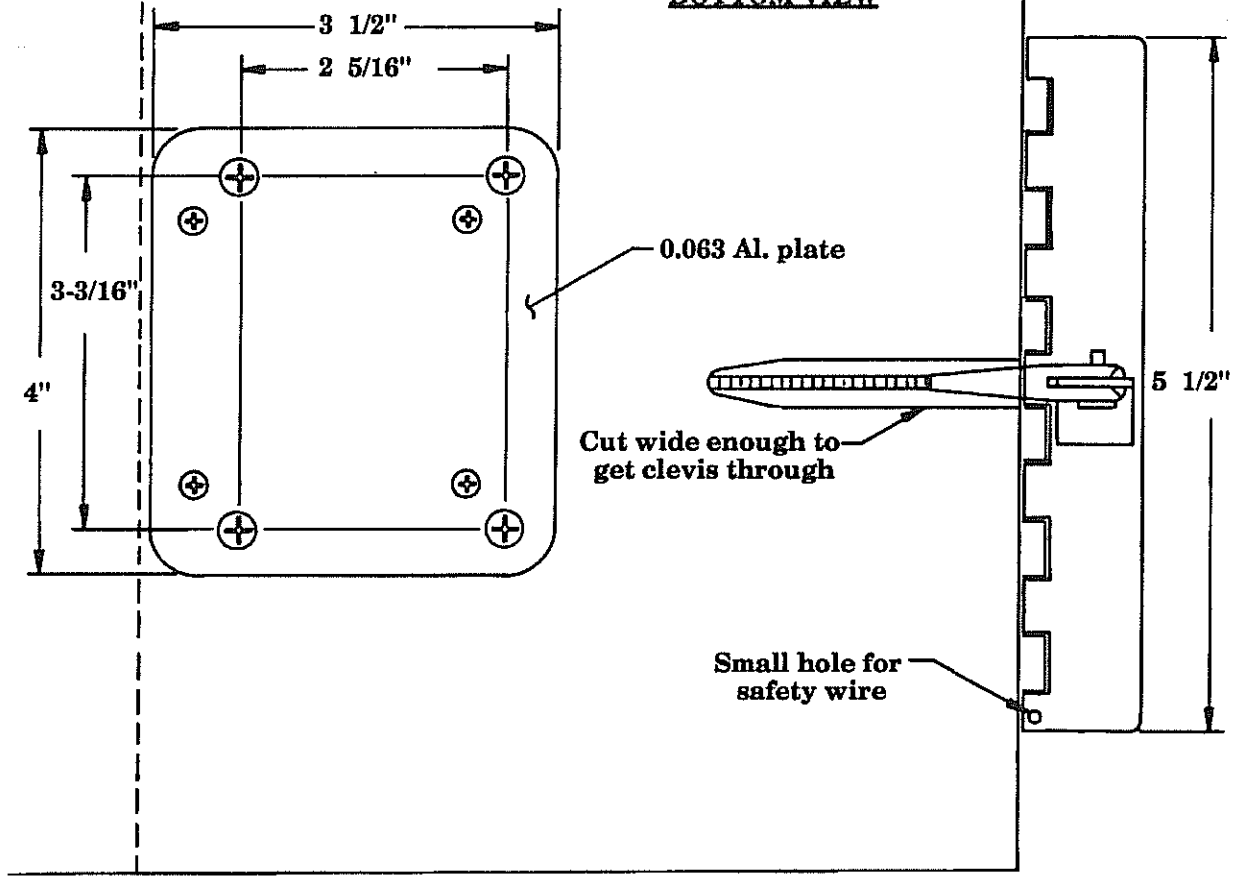

SIDE VIEW

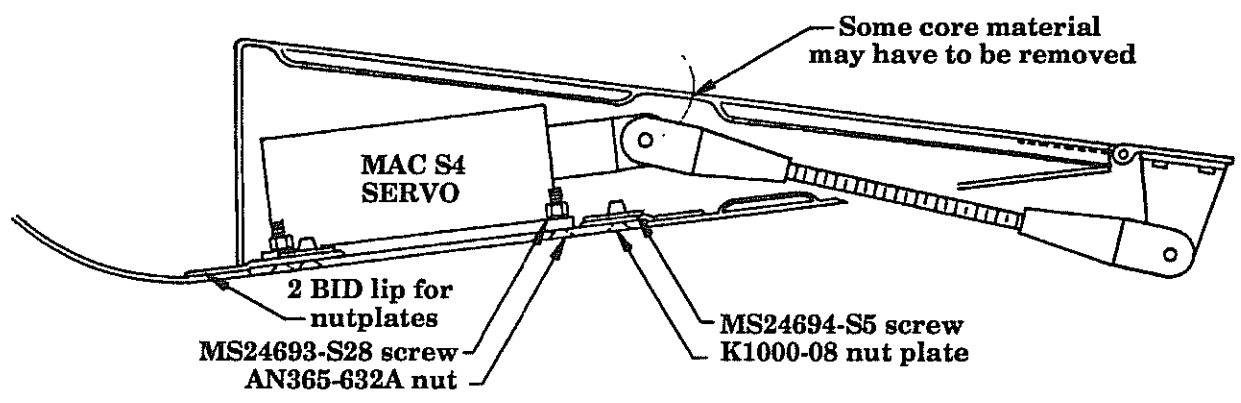

CHAPTER 11 REVISION LIST



The following list of revisions will allow you to update the Lancair ES construction manual chapter listed above.

Under the "Action" column, "R&R" directs you to remove and replace the pages affect by the revision. "Add" directs you to insert the pages shown and "R" to remove the pages.

Page(s) affected	Current Rev.#	Action	Description
11-1	0	None	
11-2	3	R&R	Changed title for figure 11-1.
11-2.1	6	Add	
11-3 thru 11-15	0	None	
11-16 thru 11-47			
11-48	6	R&R	Changed rivet part numbers.
11-49 thru 11-59	0	None	



11-i

Chapter 11

6/4-1-99

FUEL SYSTEM



CHAPTER 11: FUEL SYSTEM FIREWALL - AFT

REVISIONS

From time to time, revisions to this assembly manual may be deemed necessary. When such revisions are made, you should immediately replace all outdated pages with the revised pages. Discard the out dated pages. Note that on the lower right corner of each page is a "revision date". Initial printings will have the number "0" printed and the printing date. All subsequent revisions will have the revision number followed by the date of that revision. When such revisions are made, a "table of revisions" page will also be issued. This page (or pages) should be inserted in front of the opening page (this page) of each affected chapter. A new "table of revisions" page will accompany any revision made to a chapter.

Arrows

Most drawings will have arrows to show which direction the parts are facing, unless the drawing itself makes that very obvious. "A/C UP" refers to the direction that would be up if the part were installed in a plane sitting in the upright position. In most cases the part shown will be oriented in the same position as the part itself will be placed during that particular assembly step. However, time goes on and changes are made, so careful attention should be paid to the orientation arrows. That old cartoon of the guy agonizing over the plans for his canoe, built one end up, one end down, should not happen in real life. Especially to you.

CONTENTS

1. INTRODUCTION
2. DRAWING LIST
3. SPECIAL PARTS, TOOLS & SUPPLIES LIST
 - A. PARTS
 - B. TOOLS
 - C. MATERIALS & SUPPLIES
4. PROCEDURE
 - A. FORWARD DECK ALIGNMENT
 - B. MOTOR MOUNT INSTALLATION
 - C. FIREWALL FLANGE
 - D. HEADER TANK POSITIONING / FWD DECK BRACING
 - E. FUEL PICK UP PORT
 - F. SUMP DRAIN INSTALLATION
 - G. OPTIONAL FUEL GAUGE INSTALLATION IN HEADER TANK
 - H. FUEL TRANSFER PORTS
 - I. VENT LINE
 - J. FLOAT SWITCH (OPTIONAL)
 - K. TANK BAFFLES
 - L. ATTACHING HEADER TANK TO FWD DECK
 - M. PRIMARY FUEL SUPPLY LINE TO FIREWALL / ENGINE
 - N. WING TANK CONNECTIONS
 - O. PERMANENT FORWARD DECK INSTALLATION
 - P. REMOVABLE FORWARD DECK INSTALLATION, HINGED
 - Q. REMOVABLE FORWARD DECK INSTALLATION, SCREW MOUNTED

LANCAIR® 320FB

11-1

Chapter 11

REV.

0 / 11-1-91

FUEL SYSTEM

2. DRAWING LIST

Drawing	Page	Title
11-1	11-2	Fuel system schematic
11-2	11-9	Motor mount installation
11-3	11-10	Temporary fitting of cowling
11-4	11-12	Firewall flange
11-5	11-13	Fwd deck bracing
11-6	11-15	Header tank preparation
11-7	11-16	Header tank
11-8	11-17	Header tank fuel sump
11-9	11-19	Sump-Quick drain fittings
11-10	11-20	Sump-Quick drain mount block
11-11	11-24	Header tank "port" tube installation
11-12	11-26	Instrument panel - sight gauge installation
11-13	11-29	Vent line
11-14	11-33	Header tank baffles
11-15	11-34	Header tank to fwd deck installation
11-16	11-35	Primary fuel supply
11-17	11-36	Main shut-off valve mount bracket
11-18	11-38	Mount plate - fuel transfer pump
11-19	11-39	Fuel transfer pumps - installation
11-20	11-40	Fuel line routing - stub wing area
11-21	11-41	Grommet installation
11-22	11-43	Visual fuel transfer indicator
11-23	11-44	Restraints for visual fuel transfer indicator
11-24	11-48	Forward deck installation, hinge mount system
11-25	11-49	Fslg joggle preparation
11-26	11-50	Fslg joggle preparation
11-27	11-52	Hinge preparation
11-28	11-53	Upper hinge section to fwd deck installation
11-29	11-55	Safety wire mount tab
11-30	11-57	Forward deck installation, screw mount system



3. EQUIPMENT REQUIRED - SPECIAL PARTS, TOOLS & SUPPLIES

A. Parts

- Fwd deck
- 4) AN723A bolt
- 4) AN365-720 nut
- 3/8" 5052-0 aluminum tubing (primary fuel lines)
- FU-3 threaded aluminum plate
- Finger strainer
- AN822-6D insert
- Sump-Quick drain fittings (optional - see page 11-19 for list & details)
- Small hose clamps
- Fuel shut-off valve
- 2) Fuel transfer pump
- Hinges (optional - see page 11-45 for details)



11-4

Chapter 11

REV.

0 / 11-1-91

FUEL SYSTEM

B. Tools

- Cleco pliers
- Clecoes
- Ruler or tape measure
- Dremel™ type rotary grinder
- drill motor
- drill bits: 7/16"
1/4"
- Level, 4' (or shorter, with a 4' straight edge)
- 7/16" transfer punch (not mandatory, but nicer)
- Assorted wrenches for installing engine mount
- Pencil
- RED pencil
- Sabre saw
- Some small weight bags - 5 to 10 lbs., 3 or 4.
- Rivet squeezers



C. Materials & supplies

- epoxy
- flox
- BID cloth
- micro
- release tape
- sandpaper, assorted grit
- some 3/8" plywood or similar for bracing (see page 11-13)
- Bondo or equiv.
- grease (for release agent on some bolt threads later, most any kind will do)
- MC or acetone for cleaning
- cardboard for making templates
- fuel tank sealer (optional)



4. PROCEDURE

The header tank will be attached to the forward deck which forms the top of this tank. There are three primary methods of installing this fwd deck. One is to permanently attach it using the standard overlap joggles, this is the easiest method. The other two methods make the fwd deck always removable. This will require more initial work but the rewards can be significant, particularly if you will have a fairly full instrument panel.

You will always have access to the back of the panel when the dust cover is removed. For many instrument panel layouts, this provides sufficient rear panel access for later installations, service checks, etc. If your panel becomes complex, then often the radio stack alone will quite literally fill all the available space and a removable fwd deck can be a great blessing.

All the methods will be covered at the end of this chapter. If you are permanently bonding the deck on, it must be installed **last**, the fwd deck should be only clecoed in place until all the wiring is finished and all the engine installations are completed.

Due to removability, either of the non-permanent methods may be done at the end of this chapter, or at any time thereafter. However, it is recommended that the installation of the fwd deck be postponed until the firewall fwd installations are complete. This way the cowling is adjusted and permanently aligned around the completed engine/exhaust/baffling/etc. Then a better alignment of the fwd deck/cowl can be made.

If you wish, you may follow steps 1 through 9 of chapter 20 to complete the firewall fwd installation, before finishing this chapter.

NOTE: If you are considering installation of the "forward hinge" version of the canopy actuation system, you should now review Chapter 17, since it will affect the header tank installation.

A. Forward deck alignment

The fwd deck must be aligned at the same time as the cowl / engine for absolute best results. The canopy frame can not be installed until the fwd deck is located and temporarily held in position with clecoes or equivalent.

1. Select the fwd deck and locate it onto the double joggle along the fslg. This resultant joggle should measure 2.0" - 2.25" high when the deck is positioned. The fwd, L.E. joggle will form the lip for the cowling attach. This joggle should be in close alignment with the lower fslg cowling joggle. The fwd deck should rest on the top of the firewall bulkhead with 1-1/2" lip fwd of the fire wall.

2. Press down on the top fwd edge of the fwd deck, directly above the firewall. Be sure that the fwd deck has a good fit at the firewall, and cleco only the two front corners (in front of the firewall), from the inside of the fslg so as not to interfere with the cowl during temporary alignment.

NOTE: This firewall position of the fwd deck will not change but the aft vertical alignment of the fwd deck on the fslg could be adjusted up or down as required to achieve the best alignment of cowling to deck. To effectively "sight" this alignment, you will need to temporarily hang the engine on the engine mount. This is necessary to locate the exact position of the spinner. The spinner is, of course, what the cowling must align to at the fwd end.

NOTE: The engine is designed to mount with no upward or downward angle relative to the fslg level line. Thus the thrust line is parallel to the level line in the vertical plane of reference.

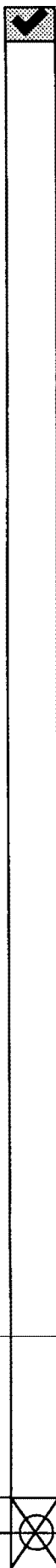

B. Motor mount installation

Although the installation of the motor and mount is "temporary" at this point, the mounting holes are permanent. So take care in locating and drilling these holes.

1. Be sure the fslg is level, check the level of the top left and right hole marks (ignore the center one for now). If they are not level with each other, cover the old line with tape so as not to get confused. Be sure to leave the hole mark exposed, use a level as a straight edge and pivot on the lower of the two hole marks. Move the opposite end up or down to establish level and mark a new level line across the firewall, see figure 11-2.
2. Using a 7/16" bit, drill through the firewall at the original pivot mark, and bolt the motor mount to the firewall using one AN-723A/AN365-720 bolt/nut, loose enough to swing it up or down. Now align the center, of the opposite side of the motor mount hole, with the level line. Holding the motor mount firmly in place, use a 7/16" dia. transfer punch or use the motor mount as a drill guide and drill through the firewall (the nylock nuts must be on the aft side of the firewall).
3. Bolt through this hole in the same manner as the first. Tighten both bolts. Now the remaining mount holes can be drilled and bolted in the same manner.
4. Mount the motor to the motor mount using the pads that are appropriate to your motor. Install the 4" extension to the engine crankshaft flange, and the 12" spinner back plate to the flange extension.

Motor mount installation

Figure 11-2

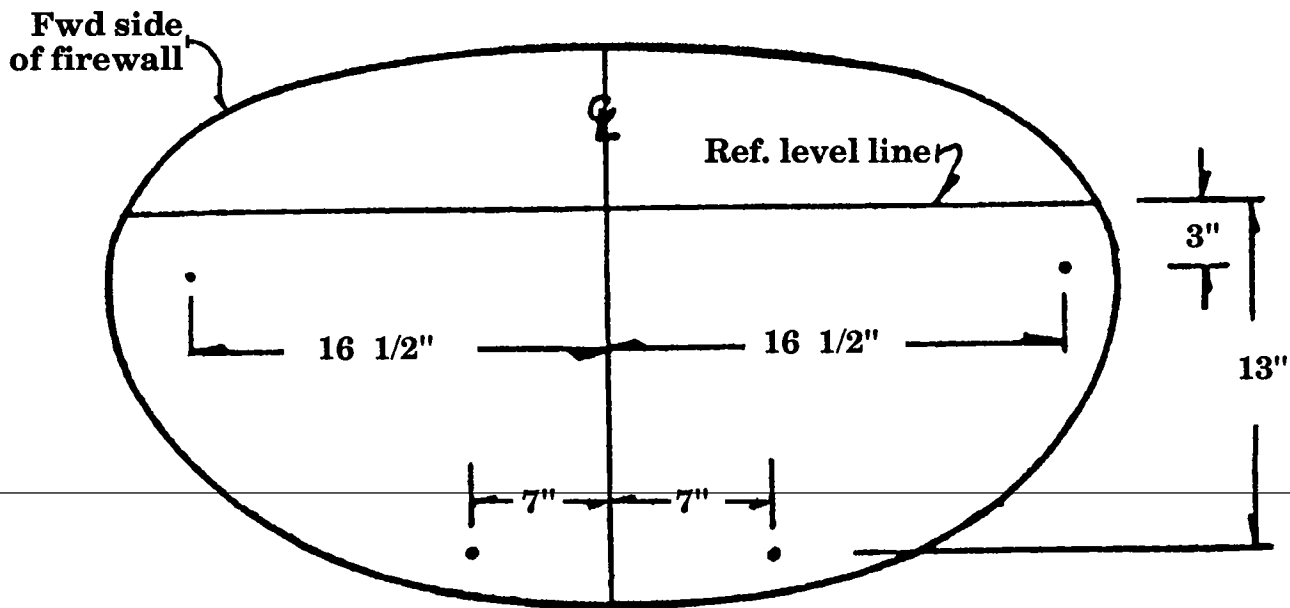

5. The upper cowl will need to be trimmed in the area behind the spinner back plate **ONLY. DO NOT TRIM ANY WHERE ELSE.** Do not trim all of the vertical face away, leave a flange of about 1" all around, see figure 11-3.
6. With the engine in place and the fwd deck still in place, set the upper cowl in place and align and clamp to spinner plate. The aft edge of the cowl will lay on top of the fwd deck and overlap the joggle, **DO NOT TRIM THE COWL AT THIS TIME.** This is just to provide a visual guide for the cowl / fwd deck angle.

Temporary fitting of the cowling

Figure 11-3

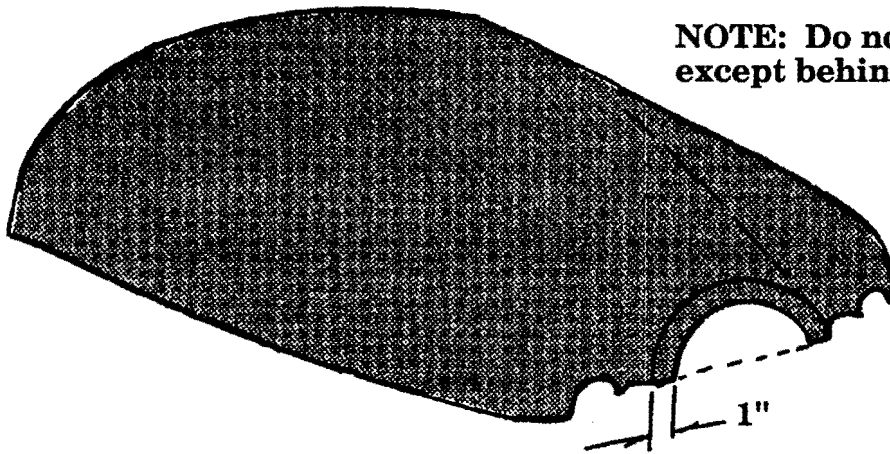

NOTE: Do not trim anywhere except behind the spinner plate.

7. With the front of the cowling located, a smooth transition should be made from cowl across to the fwd deck. This can be aided by making slight up or down adjustments of the fwd deck at the aft end of it (do not trim the cowling to fit just yet since the firewall installation will affect the final fit). All you are interested in at this time is establishing a smooth, flowing transition from top cowl, to the fwd deck. When that transition looks smooth, lock the fwd deck into position with four clecoes. Place one at each aft corner (as far aft as possible to avoid interference with the installation procedure). **CIRCLE THESE SACRED ALIGNMENT HOLES WITH A RED PENCIL. YOU'LL BE NEEDING THEM LATER, AND YOU WON'T WANT THEM CONFUSED WITH ALL THE OTHER HOLES YOU'RE GOING TO BE DRILLING....**

NOTE: If you are unable to attach the engine temporarily to make this fit check, i.e. you don't have your engine yet, etc., the next best method is to simply make the joggle height (as measured at the aft end of the fslg / fwd deck joggle line) the same height as that same joggle measures at its fwd end (adjacent the firewall position). This dimension should fall within the above mentioned 2.0" - 2.25" joggle height.

C. Firewall flange

A 3 BID flange must be added that will provide a means to attach the fwd lip of the deck where it contacts the top of the firewall bulkhead. This flange should be made such that it is permanently attached to the firewall bulkhead and "released" off from the fwd deck, see figure 11-4. This must be done before the firewall insulation (fiberfrax and stainless steel) can be installed. This 3 BID flange should extend far enough fwd for the three layers of fiberfrax insulation and the stainless steel, while still allowing sufficient room for the nut plates on the inside of the flange. We recommend a minimum of 1-1/2" firewall forward (less than 1" is inadequate) see figure 11-4. The fwd deck and cowl will be attached to this lip at a later time.

1. Apply release tape to the fwd deck, on the inside of the joggle that overlaps the firewall. Cleco the fwd deck in place.
2. Make a micro/epoxy fillet along the fwd deck overhang.
3. Apply a 3 BID (3" wide) layup as shown in figure 11-4. Be sure to overlap the fslg seam (where the fwd deck meets the fslg) by 1-1/2". Allow to cure.
4. Sand/trim the fwd edge as necessary. Be sure to leave a minimum 1-1/2" of flange as measured from the fwd face of the firewall.

NOTE: Firewall fwd may be completed at any time from here in. If you wish, you may proceed to chapter 21 to complete the firewall fwd installation, before finishing this chapter.



Firewall flange

Figure 11-4

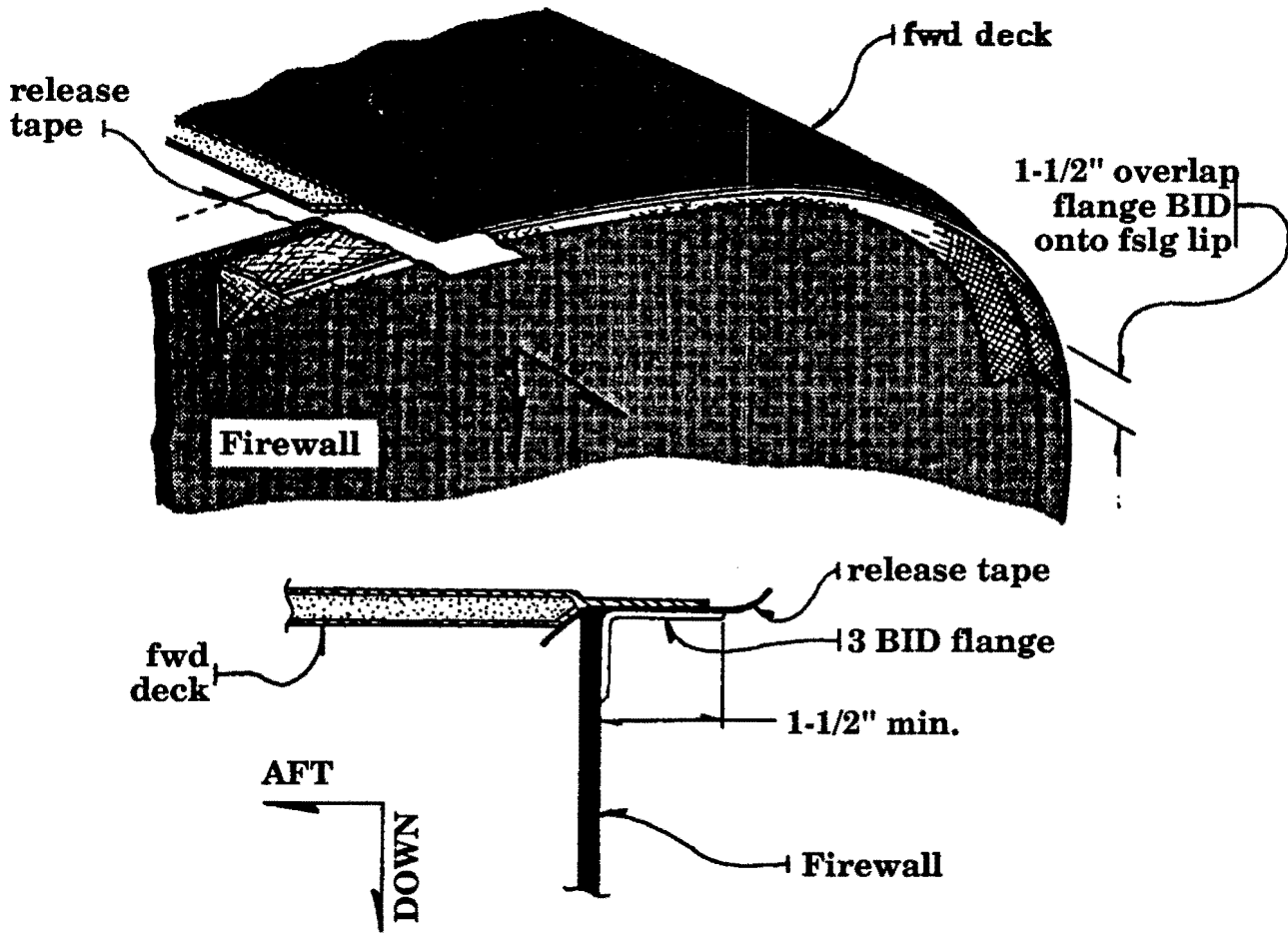

D. Header tank positioning / fwd deck bracing

1. With the fwd deck in position on the fslg, reach up from inside the cockpit and mark a pencil line to indicate where the aft face of the firewall bulkhead meets the upper inside of the fwd deck. This line will be helpful in locating the attach point of the header tank.
2. Next, you will fit the header tank onto position on the inside of the fwd deck. Note that the fwd deck is flexible and therefore could possibly be flexed too far open. This would then ruin its good fit onto the fslg. It is therefore recommended that a very simple jig or retainer brace be placed over the fwd and aft ends of the fwd deck. This brace can be made of 3/8" plywood or similar. Place the piece of plywood against the deck and trace off the decks top contour. Use a sabre saw to cut the shape out, it does not have to be very accurate. If you make the top side of the two plywood braces level, then the deck will sit very nicely on the wood braces when it is inverted.

FWD DECK BRACING

Figure 11-5

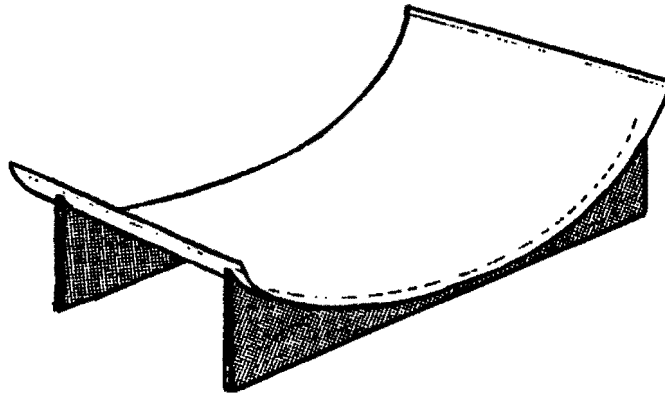

3. With the fwd deck clecoed into position on the fslg, scuff up the surfaces of the fwd deck and attach these temporary braces using a thick bead of Bondo or equivalent. Let that harden for about an hour and then lift off the deck with the braces attached. Now, you know that the deck will be held in perfect position while the header tank is bonded into position which then locks in that contour.
4. Lift off the fwd deck, with braces, and place it inverted on your workbench, see figure 11-5.

5. Fit the header tank into the deck. Note the pencil mark along the fwd edge - this is the back of your firewall. The tank should be kept AFT of this line by about 1/2". This will allow for some insulation on the back of the firewall. Some sanding on the flange of the header tank may be required to achieve its best fit into the fwd deck contour. When the fit looks good, mark a pencil line all around the edge. This will provide a visual reference of where to sand and prep the inside of the fwd deck prior to bonding the tank.
6. Fit check: The header tank has the central sump area which must fit into the recess of the nose wheel tunnel. Left to right orientation is not of much concern, but you'll need to check the fwd to aft fit. You can simply place the tank in its approximate location and lay the fwd deck (with braces attached) back into position. Cleco it down to the joggles. Now reach in and raise the tank to align with the pencil mark on the inside of the deck which locates its position. Have someone look from both sides to verify that the sump is not touching the nose wheel tunnel at any point. Adjust if necessary and clearly remark the reference pencil line.
7. Remove the fwd deck and place it once again inverted on a work bench.



HEADER TANK PREPARATION

Figure 11-6

The header tank will first require several installations prior to attaching it to the fwd deck. They are:

- 1.) Fuel pick up port..... (for finger strainer insertion - 3/8NPT)
- 2.) Sump drain port..... (1/8 NPT) (optional)
- 3.) Fuel gauge provisions..... (either sight gauge or conventional float gauge)
- 4.) Fuel ports for transfer lines.... (from the wing tanks - 1/4" aluminum lines)
- 5.) Vent line..... (1/4" aluminum lines)
- 6.) Float switch..... (in header tank)(optional)
- 7.) Baffles..... (in header tank)
- 8.) Fuel cap..... (on fwd deck)

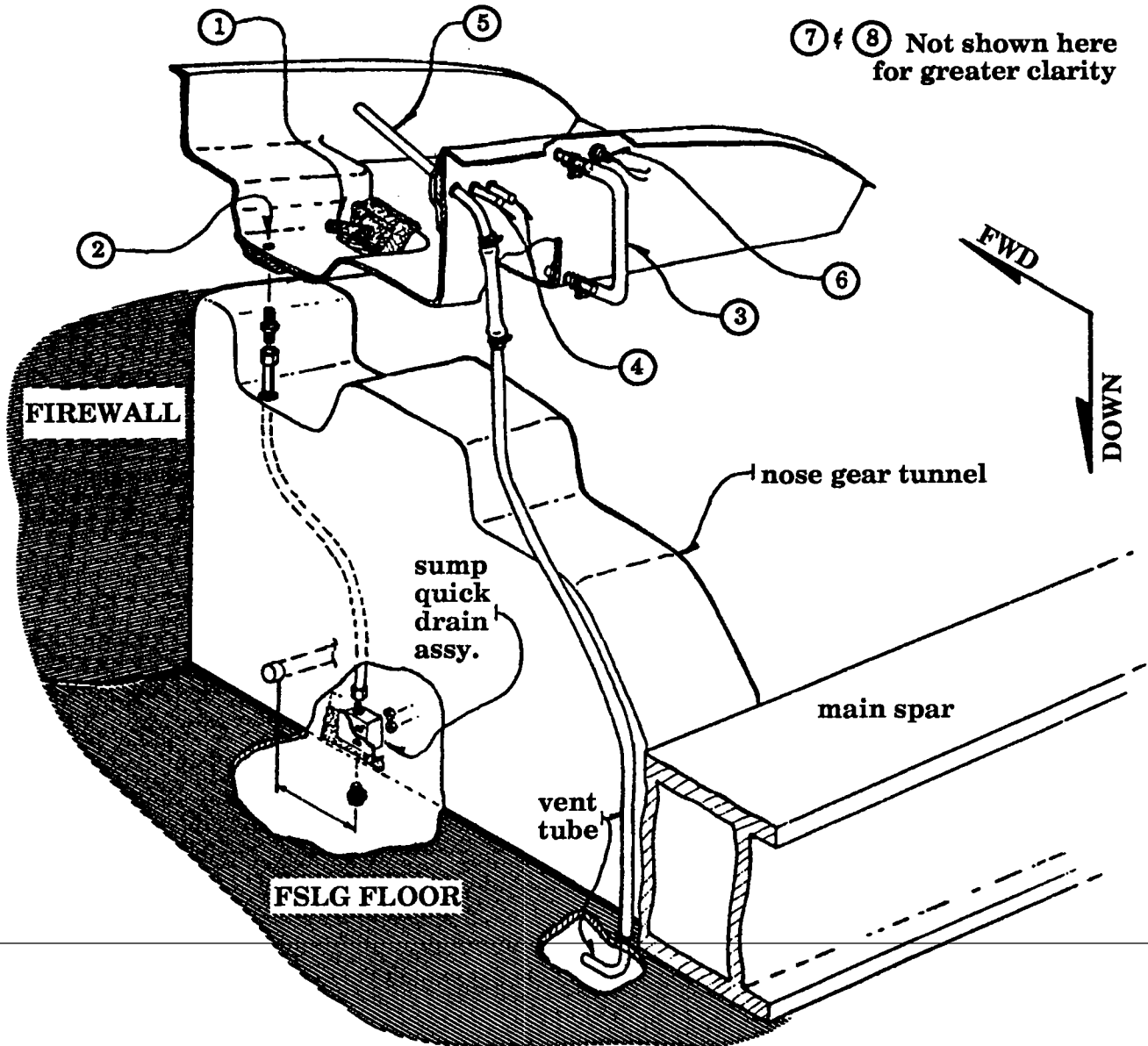

HEADER TANK
 (TOP VIEW)
 Figure 11-7

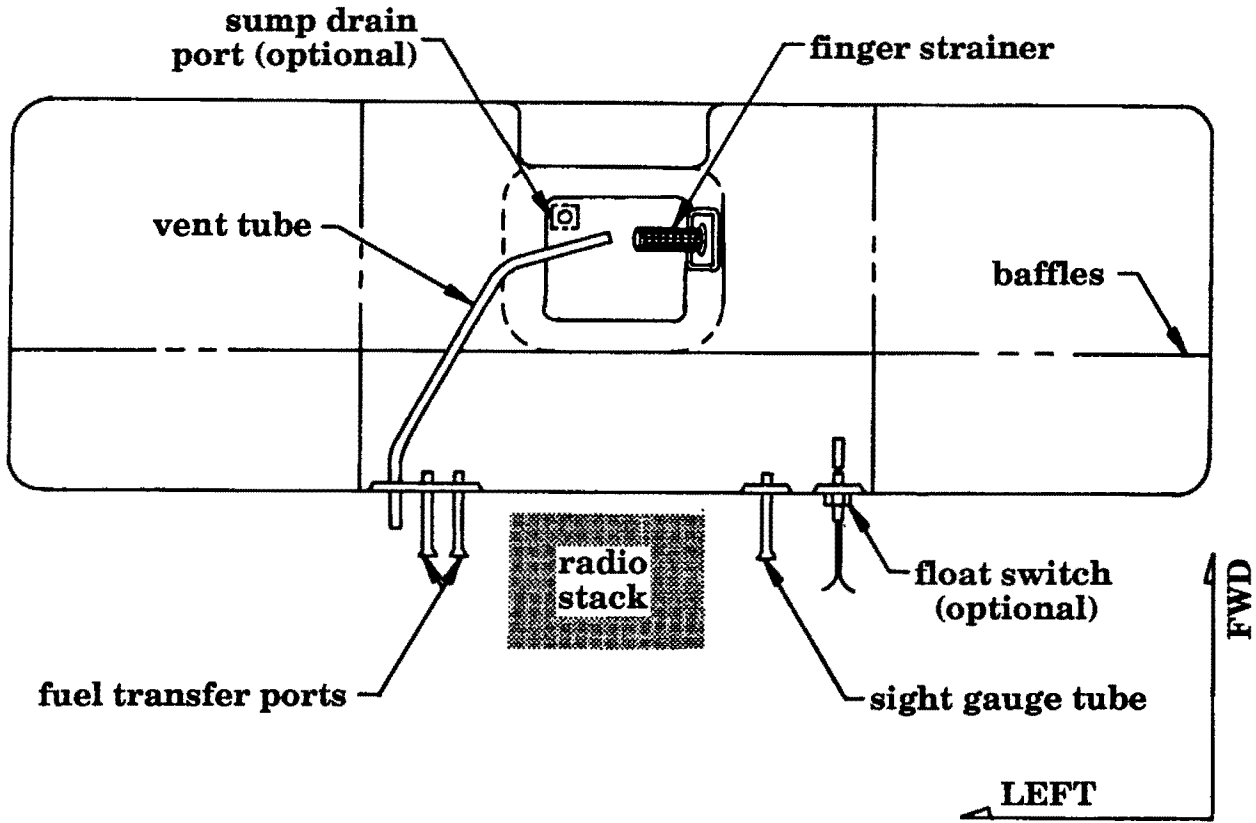

E. Fuel pick up port

This is the primary fuel line which goes to the engine. All such lines must be 3/8" diameter, either aluminum (5052-0) or flexible line (for connections from stationary objects to the engine, which is non-stationary).

1. Into the right side of the sump (passenger side), the FU-3 threaded aluminum plate will be bonded into position. This 1/4" thick block has the 3/8 NPT (pipe threaded) hole in it.

NOTE: Note the direction of taper in this threaded hole. The wider side of the taper **MUST** be facing the outside of the tank.

2. The best method of installing this fitting is from the inside. Rough up the sump wall and fit the block into place. It is best to file a bevel on the sides of the block so that it fits well to the sump wall and provides for a smooth transition from the plate to the sump. This smooth transition is needed for a good attach of the 3 BID that will be applied over the top.

NOTE: This fitting block will naturally position the hole up slightly from the very bottom of the sump. This is correct. The hole for the finger strainer should **NOT** be at the bottom of the sump. See figure 11-8.

Header tank fuel sump

(Viewed from aft looking fwd)

Figure 11-8

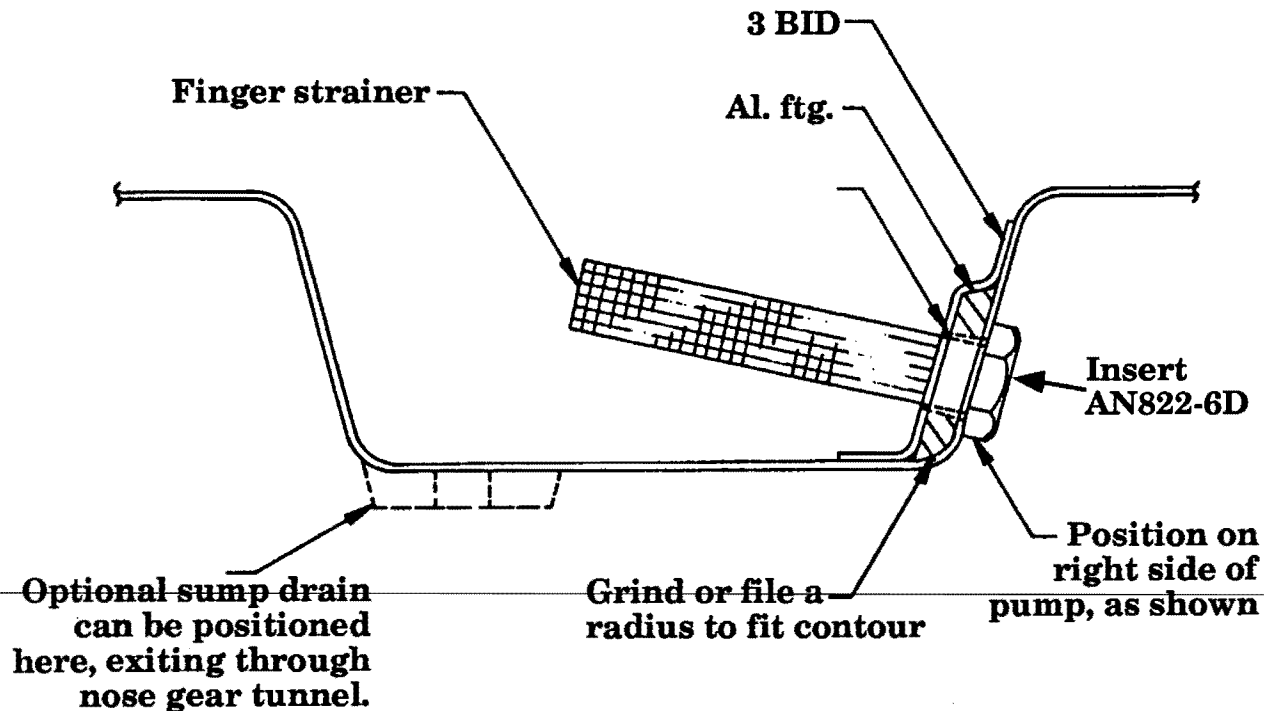

3. Locate and cut in the through hole in the sump for the finger strainer that will thread into the fitting block. When the fit is good, put a slight amount of grease around the threads of the finger strainer as a "release". Be careful NOT to gob a lot of grease onto it, just enough to provide a thin film to serve as a release in case any epoxy gets onto it during the next step.
4. Rough up the face of the aluminum plate that attaches against the side of the sump. Use 80 grit. Clean with acetone and *immediately* bond into position with epoxy/flox. Insert the lightly greased finger strainer through the hole to assure proper alignment and allow to cure. Apply weights against the fitting block during cure, about 5 lbs. is sufficient weight.
5. After the above cures, add a 3 BID tape over the top of the fitting block. Make sure that there are no air pockets or voids around the fitting block. Use epoxy/flox as a filler if necessary. The 3 BID can be positioned over the through hole (finger strainer is now removed along with any traces of grease) in one piece. The cut out for the hole can be made with a sharp Xacto blade after it reaches the "green" stage during cure. Be sure that these 3 BID are smooth and thus have no crevices or burrs which could snag contaminants. After cure, sand lightly to assure a smooth surface along the tank interior.



F. Sump drain installation

This is an optional installation which provides an additional means of draining the sump. The header tank line to the engine should always pass through a gascolator, mounted on the firewall, but an additional sump drain can be installed if desired. This line can be routed directly down through the nose gear tunnel and be accessed from inside the fwd end of the nose gear tunnel from below. Items for this optional installation are not included in standard Lancair kits. If you do choose to install this additional sump drain, fittings can be quickly shipped from either Aircraft Spruce and Specialty or Wicks Aircraft Supply.

Sump - Quick Drain Fittings

Figure 11-9

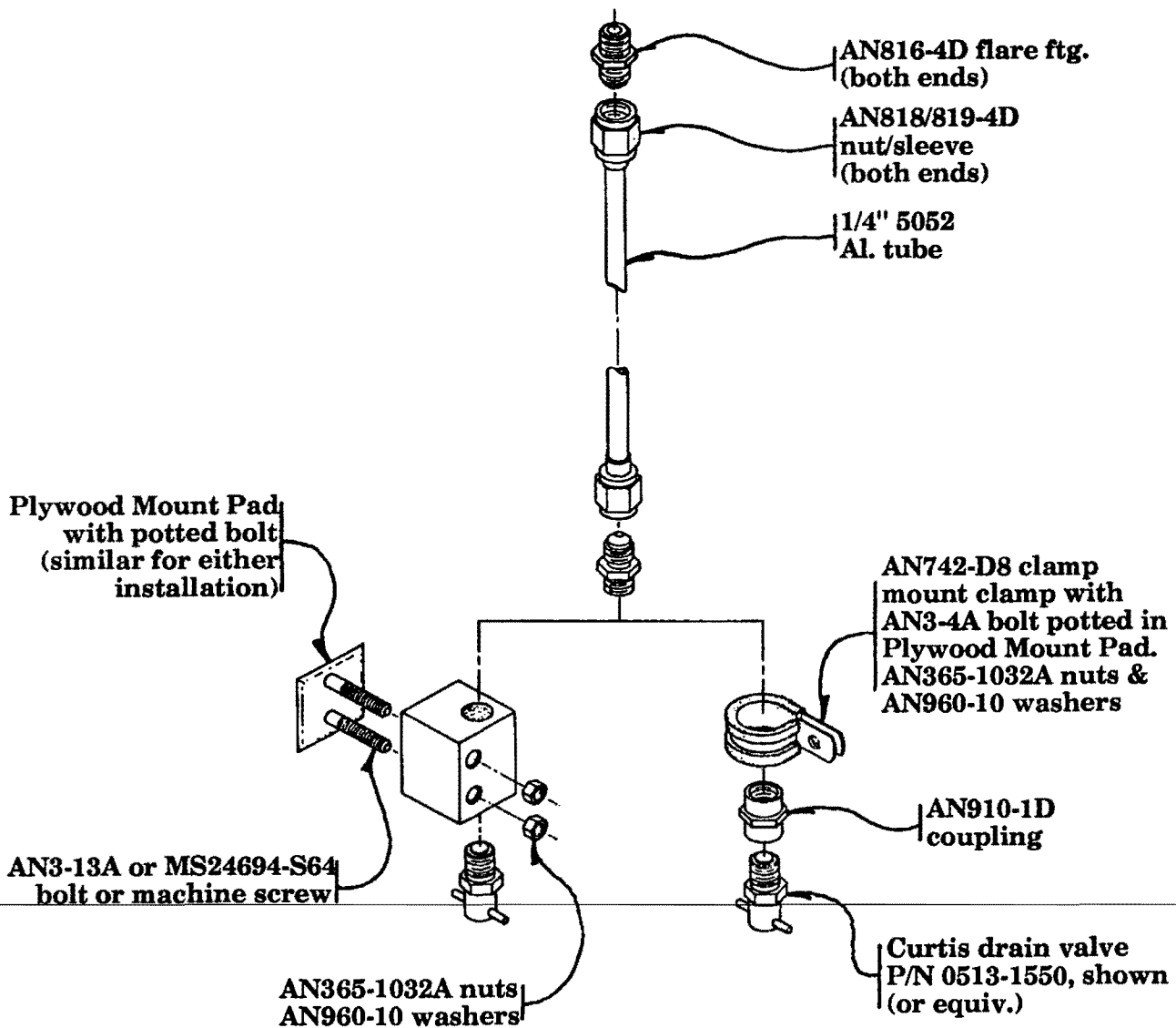

If so desired, you may fabricate a block to install the sump drain. The following drawing can be followed:

Sump - Quick Drain Mount Block

Figure 11-10

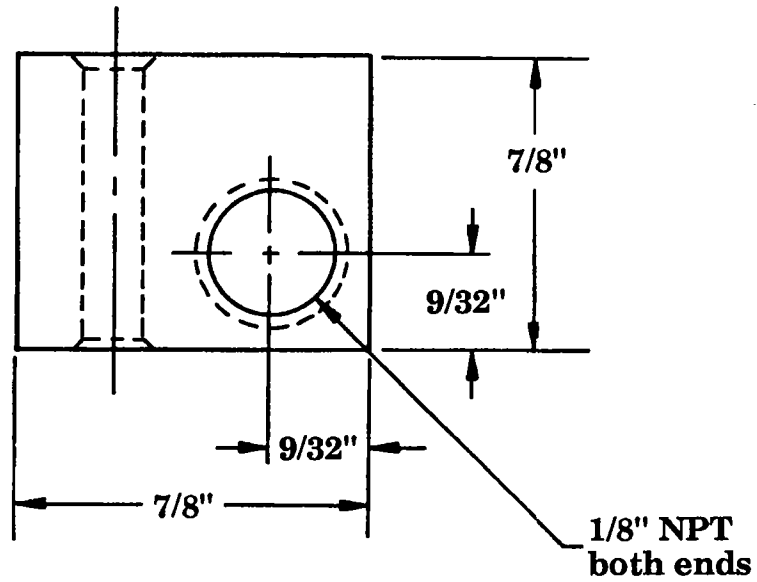

SHOWN TO SCALE
Material: Aluminum

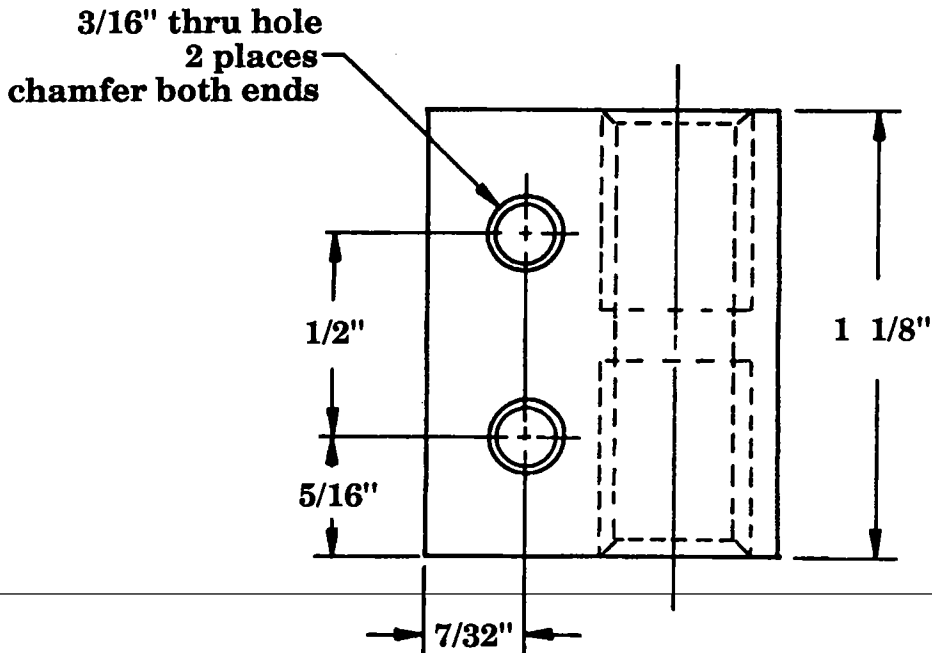

1. The sump drain fitting block can be brass or 1/4" phenolic. Threads can be cut into the phenolic block, make it the same size (1/8 NPT) as the brass type. Your Lancair 320 kit does supply three 1/8 NPT fitting blocks made of brass. One can be used for this purpose (the other two are for the wing tank drain sumps. Phenolic can also be substituted here for a weight reduction if desired).

WARNING: If you use a phenolic plate, take care in cutting the pipe threads and do not over tighten the fitting into the block. This could break the threads and cause the fitting to work loose.

2. This header tank sump drain fitting block should be bonded to the OUTSIDE of the sump bottom. The block should also be positioned to the far left (pilot side) of the sump area. This allows you to attach a 1/4" aluminum drain line such that it fits down through the tunnel close against the left side. (In contrast, if the line were to exit straight out the center of the sump bottom, it would be running into and through the center of the tunnel which would be undesirable.) Grind off the gel coating on the tank exterior where the fitting block will attach and include an area 1" around the block where BID will attach.

WARNING: You can not attach BID tapes to the gel coated surface. They will not bond and would likely fail at some point in time. Be sure that all gel coat material is removed where you are applying BID tapes to the exterior of this header tank.

3. Attach the sump drain fitting block in a manner similar to that used for the previous fitting block. Add 3 BID over the fitting block in a similar manner as well.
4. A flare fitting can now be screwed into this sump drain location (AN816-4D). Next, reposition the fwd deck/header tank onto the aircraft. Locate the sump drain fitting position relative to the nose gear tunnel. Place a mark, directly under the fitting, on the nose gear tunnel to reference this sump drain location.
5. Now remove the fwd deck / header tank and note the reference mark. An aluminum line will be attached which then punches straight down through the nose gear tunnel, near the left side. See figure 11-6.
6. Position the through hole such that there is a remaining flange area over which the grommet can fit. The standard elastic grommet (AN931-4-12) will require 1/8" all around the 3/4" hole. Punch a 3/4" dia. hole through the tunnel and install the elastic grommet.

7. Attach a length of 1/4" aluminum line. The line should have an AN818 / 819-4D nut connected to the top end of the tubing. The tubing must then extend down to the base of the nose wheel well, with extra length for routing aft of the over center pivot.
8. With the 1/4" aluminum line attached, guide it down through the 3/4" hole and position the fwd deck / header tank back on the plane.
9. Locate a point at the base of the nose gear tunnel, approx. 3" aft of the over center pivot, where the line will terminate and the quick drain assembly will be installed. There are two methods of making this assembly, see figure 11-9.
10. Install a typical mounting pad (see figure 11-18) with 2 BID for the quick drain assembly about 3" aft of the over center pivot, and about 1" above the nearest surface of the nose gear door. Bend the aluminum tubing inside the nose gear tunnel, making a smooth flowing line from the through hole in the top to the quick drain assembly mounted at the bottom. Mark the line for a position to cut. Install the flare with an AN818 & 819 nut and sleeve.

WARNING: When making a sump drain check, you must drain an amount of fuel equal to the amount in the full line **BEFORE** any fuel specimen sample can represent what is up in the sump area itself. Thus you should fill the line with fuel and measure the amount it will hold. Then when making field samples, you'll know how much to drain before an accurate sump reading can be made each time. Generally about 1 oz. is sufficient.

NOTE: The header tank sump can easily be inspected "visually" with a flashlight since the sump is directly below the fuel cap. This visual inspection is recommended.

NOTE: When installing the pipe threaded fittings such as finger strainers, etc., use a standard pipe thread sealing compound. This is preferred over the teflon tape types since the tape can shear off and get into the lines.



G. Optional fuel gauge installation in header tank

There are two approaches to reading the fuel quantity in the header tank. One method is very simple and uses a "sight gauge". This is merely a clear vinyl tube (material is supplied in kits) which makes a loop from the bottom of the tank to the top of the tank. The line will thus attach at the bottom of the tank, run fwd to face of instrument panel, up the panel and back to the top of the tank. Thus you'll always see what you've got - WYSIWYG (What You See Is What You Got).

Many builders prefer to install a sender in the tank with an instrument gauge on the panel. The feeling is that it is more sophisticated in appearance. It's a matter of personal preference. Both methods will be discussed.

1. Sight gauge
Refer to figure 11-6 for an overview.
 - a. Decide on which side of the radio stack you want the gauge to be located. Locate a point 4" left or right of tank centerline along the aft lower corner of the tank. Make a 1" x 1" x 1/4" phenolic block with tapered edges and bond it into the inside corner of the tank. Apply a 3 BID layup over it contacting 1" all around.
 - b. Locate a position directly above the bottom phenolic block and bond a similar sized phenolic block onto the inside of the tank 1" below the top. Lay a similar 3 BID patch over it too.
 - c. Next drill a 1/4" hole through the center of each phenolic block. Drill through the entire tank wall.
 - d. Make a short tube (about 3" long) out of 1/4" aluminum. Place a small flare on one end only. This flare should be about half the size of a standard type flare which would be used with a flare fitting. The purpose is to create a slight bulge over which a flexible tube can be sealed. The tube measures .250" in diameter, the flare should measure about .300".
 - e. Use a small amount of structural adhesive to bond the tube length into the phenolic. Insert the tube such that it extends 1/2" into the tank interior. Generate a good sized fillet of adhesive around the tube on both inside and outside.
 - f. It is advisable to add a 3 BID tape around the tube for added bonding strength. These tapes are best laid up one at a time from small strips of bi-directional cloth scraps. You need only apply these to the tube around the inside of the tank. See figure 11-11. The sight tube will be slid over these two tubes.



Header Tank "PORT" (tube) Installation

Cross section view

Figure 11-11

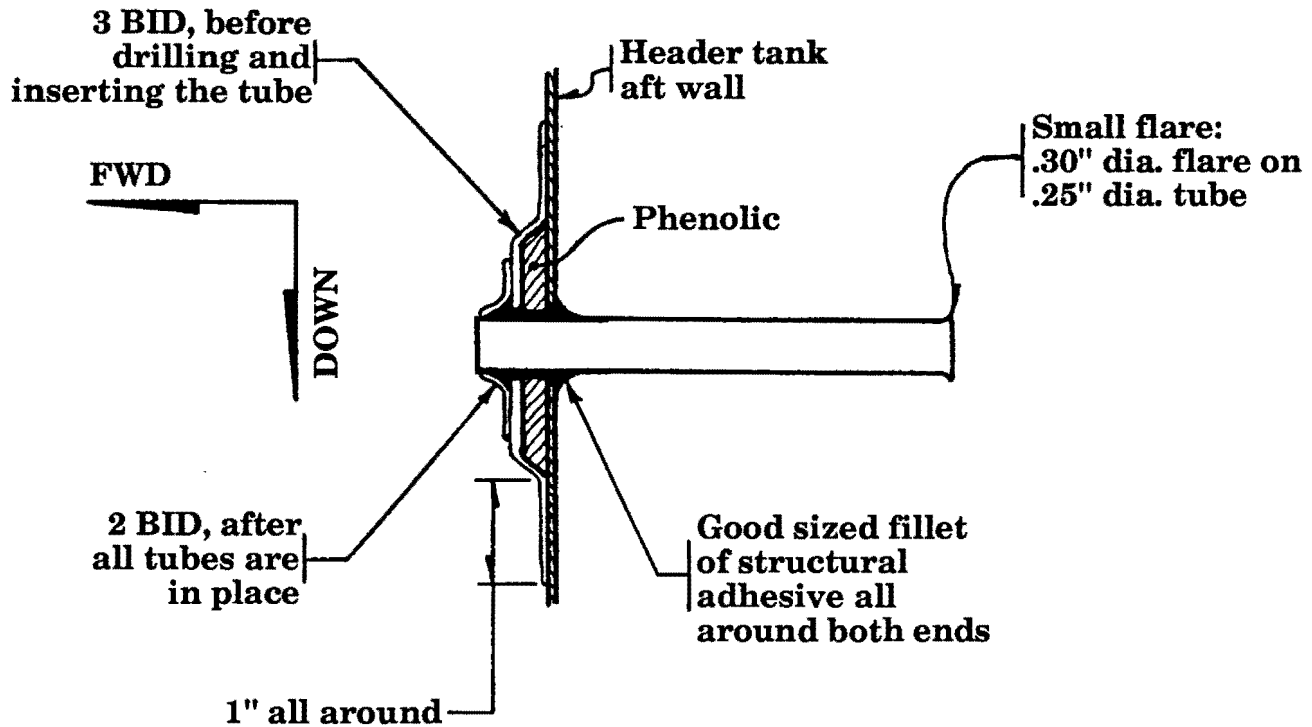

- g. On the face of your instrument panel, locate the position where you want the sight gauge to be installed, see figure 11-6. Drill a 3/8" hole at the base of the panel and another at the top of the panel. The 3/8" O.D. sight tube will run up the panel through these holes. Use a piece of sand paper around a small piece of tubing or similar to sand a radius in the holes such that it helps the tube make the turn up the panel face.

NOTE: We generally position the tube against the right side of the radio stack area, since the left side tends, after time, to become packed tight with flight instruments.

- h. To make a nice looking housing for this gauge, place a piece of 3/8" aluminum tubing (waxed) in position and fill the area around it with epoxy/micro. A piece of wood (waxed) can be temporarily placed to form a "dam" to hold the micro in position until it cures. At that time, remove the dam and the tube and punch through at the top and bottom for the entrance and exit of the sight gauge tube. With a little light sanding, this will make a very nice looking, custom installation for the sight gauge. If your instrument panel is dark colored, place a clean white stripe (about 1/8" wide) in the depression where the sight tube will locate. A white vinyl tape works well. That will make reading the fuel level easy. An alternate method is to carve a scrap piece of foam to the desired shape, then fiberglass in place. Refer to figure 11-12.



Instrument panel - sight gauge installation
viewed from the right seat
Figure 11-12

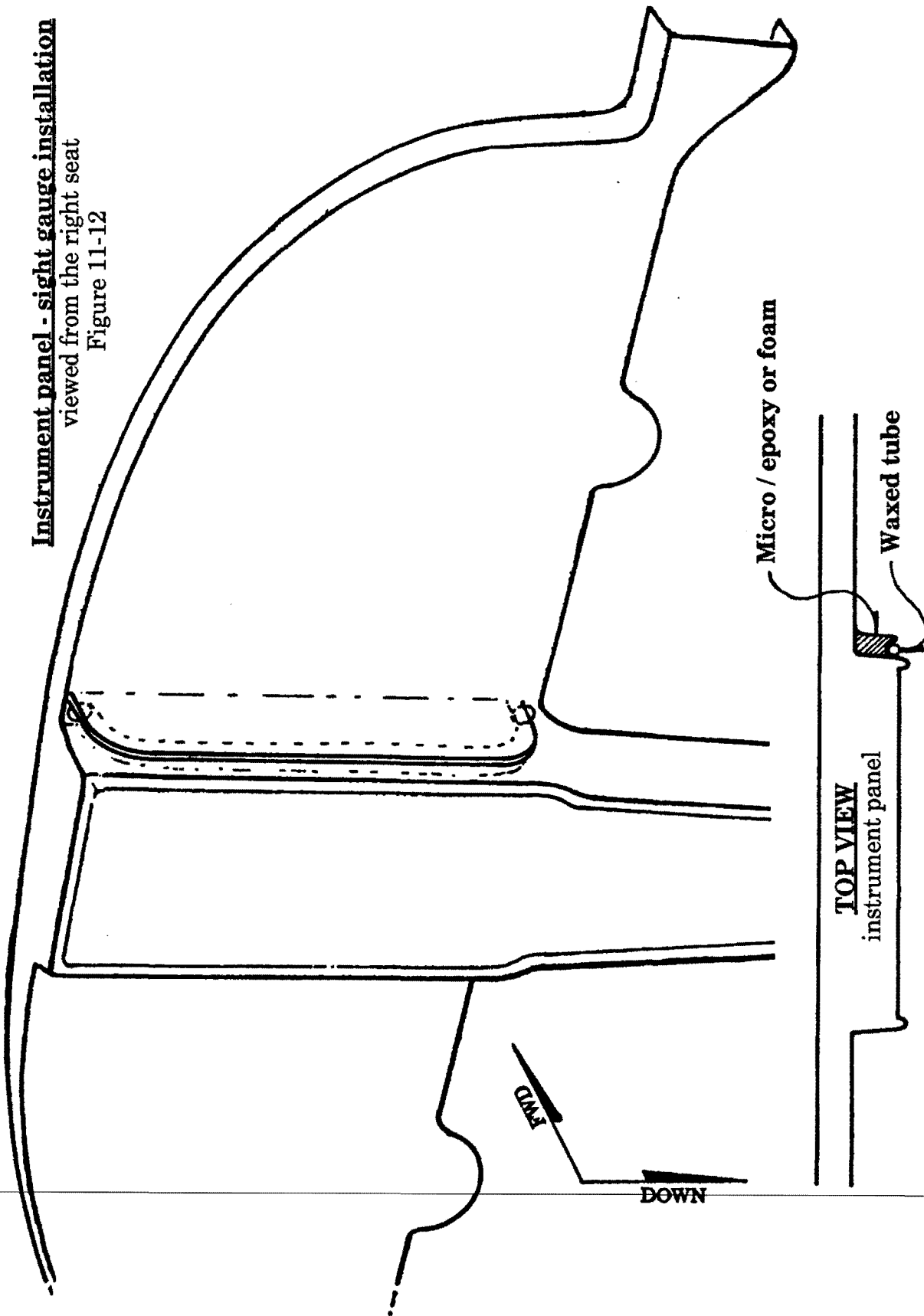

2. Remote fuel sender (optional)

Any of the remote type of fuel senders can be installed into the header tank. They will generally install from either the bottom or the side, along the top. Obviously, a top mounted sender would not work.

- a. Whichever sender type you choose, it should generally be mounted near to the center of the tank so that the reading will remain the most steady in banks. This also allows for the full height of the tank to be measured.
- b. There are several gauges available, most have what is a standard 5 bolt mounting pattern on them. They will require a through hole so that the sender can be mounted from the outside and a gasket placed on the outside of the tank will seal it.
- c. The mounting collar is usually a piece of 1/8" aluminum with 5 threaded holes in it for AN3 bolts. This plate can be bonded to the inside of the tank just like the method used for attaching the brass fitting blocks. Apply 3 BID over the plate and during the "green" stage of the BID cure, trim away for the through holes and the bolt holes.



H. Fuel transfer ports

The standard fuel management system has the wing tanks transferring fuel to the header tank. This is via an electric fuel transfer pump, one for each wing. Since the engine is not directly operating from the wing tanks, a 1/4" line can be used for transferring.

1. Make a phenolic block 1/4" x 1" x 4". Taper the edges on about a 60° angle.
2. Locate a position on the left inner side of the header tank rear vertical face. This position should be such that the block is at least 1/2" below the top. It should also be left of center such that it clears all radio trays, etc. This means it's inbd edge must be at least 3-3/4" left of center to provide a little clearance room.
3. Attach the phenolic block to the inside in the standard manner and apply 3 BID over it.
4. From the inside: mark the phenolic block for 3, 1/4" holes. Evenly spaced, 1" apart. Drill these holes from the inside.
5. Make two short (3") pieces of tube (1/4" aluminum 5052-0) and put a slight flare on them.
6. Bond them into the two inbd holes in the phenolic such that they extend 1/2" into the inside of the tank. Rough up the tubing a little and use structural adhesive. Leave a good sized fillet around the tubes at each side of the tank wall.
7. Add 3 BID strips around the tube ends on the inner side where the tubes protrude. The third hole is for the vent tube. It is recommended that you wait until you have installed this vent tube before adding these 3 BID tapes so that you can run these tapes around all three tubes at the same time. See figure 11-11.



11-28

Chapter 11

REV. 0 / 11-1-91

FUEL SYSTEM

I. Vent line

The header tank must be vented to atmosphere to prevent an air lock as fuel is drained out to the engine. A vent line will be installed which effectively goes from the fwd top center of the tank and exits out the bottom of the fslg. Refer to figures 11-6 and 11-7.

- Using a length of 1/4" 5052-0 aluminum line, fit it to transition across from the third remaining hole in the phenolic block, across to the fwd center of the tank, at the top. It should end about six (6") inches aft of the tank fwd face. That will place it actually near the fwd-aft center of the tank which will be close to the filler port.

The tube should extend aft, through the phenolic block and make a downward turn as it exits the tank. There a small flare will be placed to accept a hose connection. See figures 11-6 and 11-13.

Vent line
Cross section view
Figure 11-13

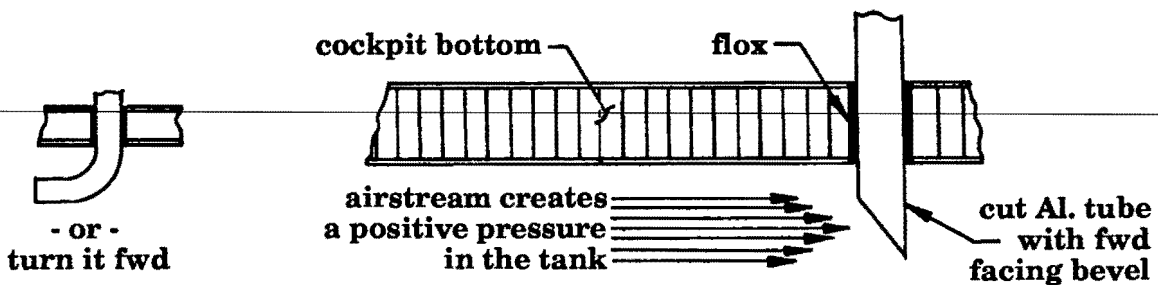
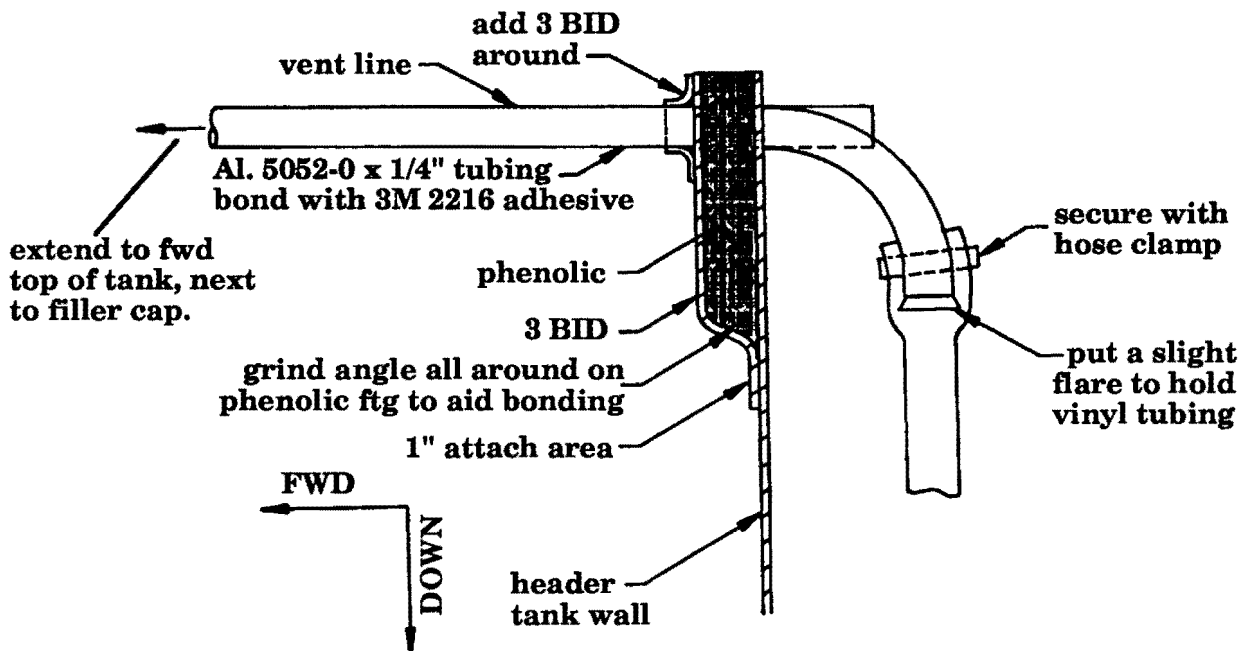

2. With this length of tubing cut, fitted and flared slightly, insert it through the phenolic block. Use structural adhesive to bond into the block. Just leave the length of line loose in the tank area for now, it will be secured later.
3. Now add the 3 BID around this vent tube and both filler tubes on the inside of the tank at the phenolic block locations.
4. Once the tank and fwd deck are in position, the vent line will connect via a hose connection and extend down to the base of the fslg. The location of the tank vent out of the fslg is not too critical. Consider the placement of the vent line exiting the fslg relative to leg room, etc. Also be sure that it does not exit so close to the nose gear tunnel that it actually falls under the overlap lip of the nose gear door onto the fslg bottom.
Generally, If you drill the 1/4" hole close to the fwd face of the main spar and in a line just outbd of the nose gear tunnel, the location will be good. See figure 11-6.
5. Use a length of 1/4" aluminum line that extends 1/2" out the bottom of the fslg. This line can extend up to a point within 3-4" of the vent line that exits the header tank. Place a slight flare on this end of the line and cut the outbd end of the line on a 45° angle INTO the airstream. See figure 11-13.
6. Use a short length of hose to make the vent line connection with small hose clamps to secure at both ends.



J. Float switch (optional)

To prevent the possibility of forgetting to turn off the fuel transfer pump and thus pumping overboard, a float switch connected to a warning light can be installed. Aircraft Spruce and Specialty carries a switch which works well for this application.

NOTE: Some of the switches that we have received did not have sufficient buoyancy in gasoline's low density to activate the switch. We cut the end off the float switch, epoxied 2 wine corks end to end (3" to 4" total length), sanded the cork to fit the inside diameter of the float cylinder, then covered the cork with epoxy and epoxied it into the float cylinder.

1. The float switch can be installed near the top of the aft wall of the tank with a threaded phenolic block that is bonded and 3 BID taped into position. Again, it is best to install this away from the center radio stack area.
2. Be sure to test the float switch out (in gasoline) so you'll know exactly where it activates. The switch should be set up to close the contact points when the float is raised by the rising fuel in the tank. Thus, as the tank is filled, the light will let you know it and remind you to turn the filler pumps off.
3. If you wire the float switch light through a DPDT (double pole, double throw) fuel transfer pump switch, then when you turn the switch off, the warning light will also go off. Otherwise you'll have to wait until the tank drains down some before the float drops and the light goes off.



K. Tank baffles

The header tank should have sloshing baffles installed. These baffles prevent fuel from moving too fast in the tank which could upset balance and trim. As always, make cardboard patterns first, refer to figure 11-7 for positioning.

1. A simple method of making the baffles themselves is to lay up 2 BID on a flat surface that has a plastic tape release on it. Allow to cure.
2. Trim this material to form the baffles as shown in figure 11-14 (as always, make cardboard patterns first, we can't stress it enough). Use a straight edge along the top of the tank to check pattern fit.
3. Use 1 BID tapes to hold the baffles in position in the tank.

WARNING: The cutouts in these baffles is very important. You must be careful to not isolate any "pockets" where fuel would be trapped and contaminants could gather. An area that could gather contaminants could cause a sudden release of the contaminants which could in turn travel over and cause a total and instant blockage of the pickup port thus causing the engine to quit. **BE VERY CAREFUL ABOUT THIS.** Also, for the same reasons, the inside of the tank should be smoothed where tapes have been applied.

4. Where the vent line crosses the baffles, make a notch and place a 1 BID tape to secure the vent line in position. The inbd end of the vent line will simply be bent such that it remains approximately 1/4" below the top surface of the tank. This can be established with the use of a straight edge along the top of the tank and checking for proper clearances. Adjust the tube as necessary by making slight bends in it.



Header tank baffles

Figure 11-14

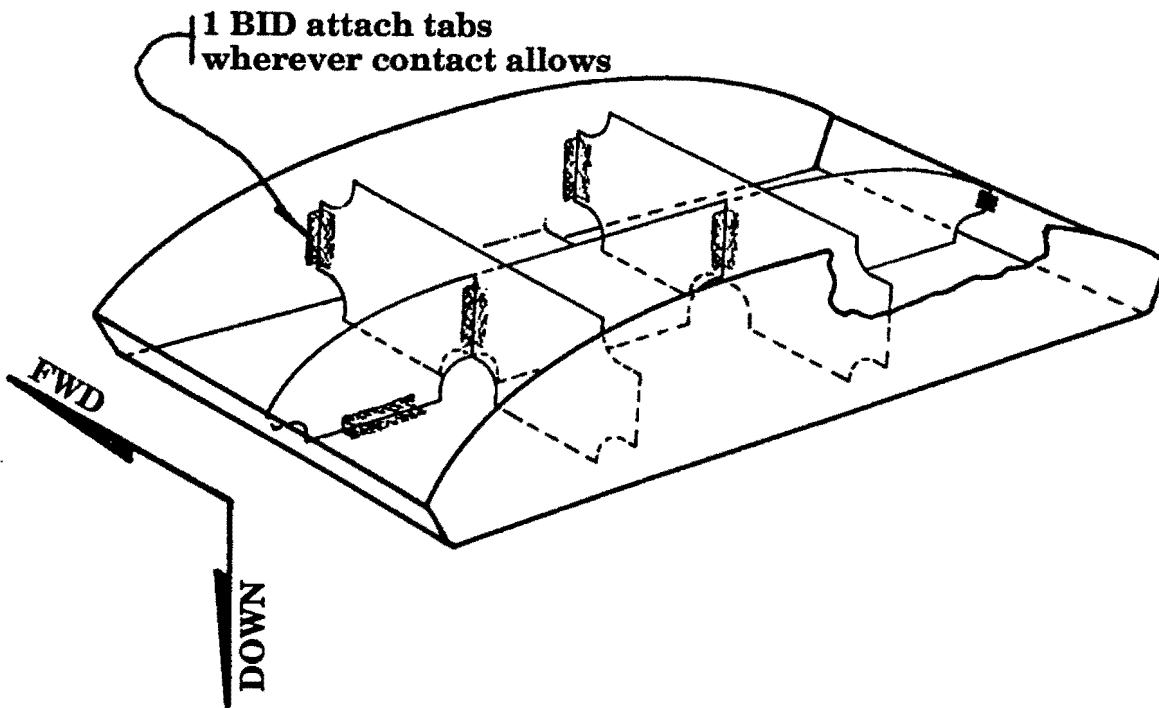

L. Attaching header tank to fwd deck

With all of the inside fuel tank fittings installed, the tank is ready to be permanently bonded to the upper fwd deck. The upper inside of the deck must first be prepared.

1. Lightly sand the entire area of the tank plus an area 3-4" outside of that area.
2. If you are using the PRC 1422 sealer, it should be applied to the fwd deck in a manner similar to that used to apply it to the wing tanks. A primer is also recommended. The primer and sealer must be applied only to the areas which will be inside the tank itself (not to the areas where the tank will be bonded into position). The other alternative is to apply two thick coats of resin over the surfaces.
3. With the fwd deck still in its cradle (inverted on a flat surface), apply epoxy/flox around the perimeter where the tank lip mates and install the fuel tank, see figure 11-15. Use weights to hold it down against the fwd deck. If the lip on the tank does not fit tightly against the fwd deck, simply fill the voids with epoxy/flox. Try to position the epoxy/flox such that most of the squeeze out will be on the outside of the tank. You don't want the stuff dropping down into the tank interior.
4. After cure, sand smooth, clean and apply a 3 BID tape all around the perimeter. This tape should be 2-1/2" to 3" wide. Contact 1-1/2" to 2" onto the fwd deck interior surface. Be sure that there are no voids or air bubbles which could generate a leak later.
5. This will complete the header tank assembly. The two plywood cradles can be knocked off now. There will be some Bondo residue remaining, just sand that off.

Header Tank to Fwd Deck Installation

(inverted)
Figure 11-15

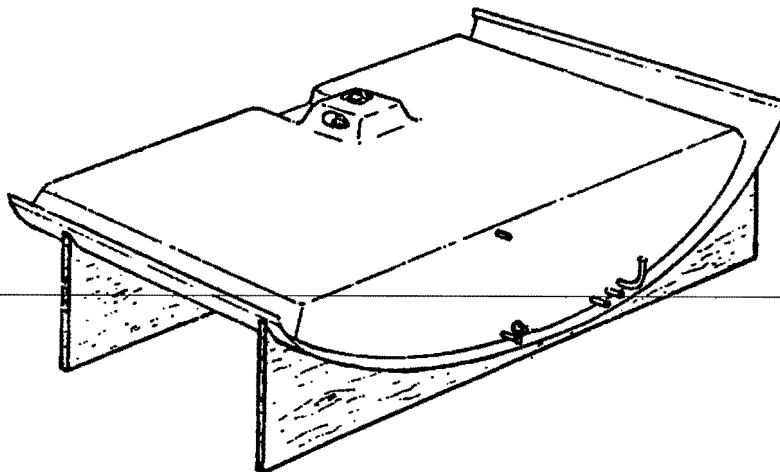

M. Primary fuel supply line to firewall / engine

The fuel supply to the engine will originate from the Main Fuel Pickup Port located on the right side of the header tank sump. The 3/8 NPT fitting block has already been installed into position for this use.

The fuel line (3/8" 5052-0 aluminum tubing) is routed from this fitting, aft, making a "U" shape under the header tank where it passes through a Main Shut-Off Valve and then fwd to the firewall and down to the point where it passes through to the engine, see figure 11-16. The purpose is to locate the Main Shut-Off Valve where you can reach it from the pilots seat (the fuel system fwd of the firewall is covered in chapter 21). Place pipe thread sealer around the threads on all fittings.

Primary fuel supply

(cut away view)

Figure 11-16

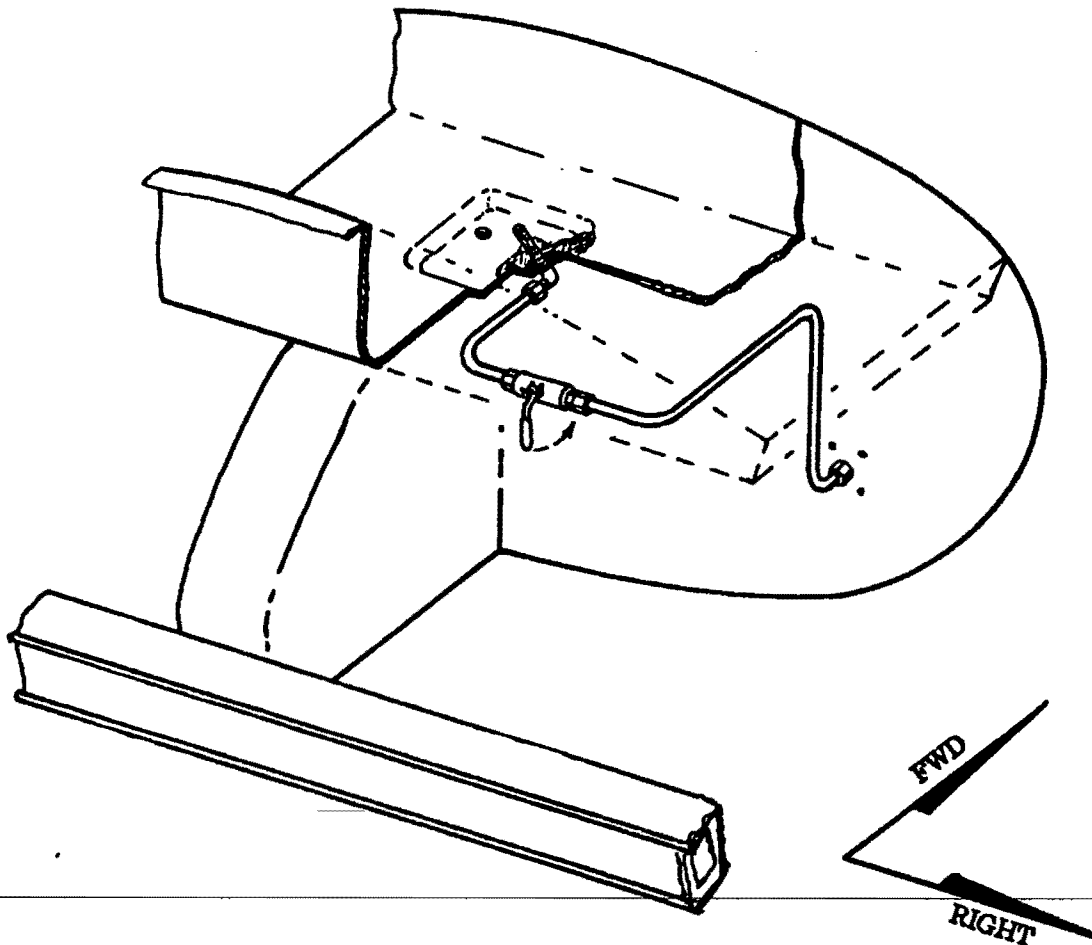

1. Remove the fwd deck/header tank from the fslg.
2. Per figure 11-17, use aluminum angle stock (1" x 2" x .125" thick) to make the mount bracket for the Main Shut-Off Valve attachment onto the base of the header tank.

Main Shut-Off Valve Mount Bracket

Figure 11-17

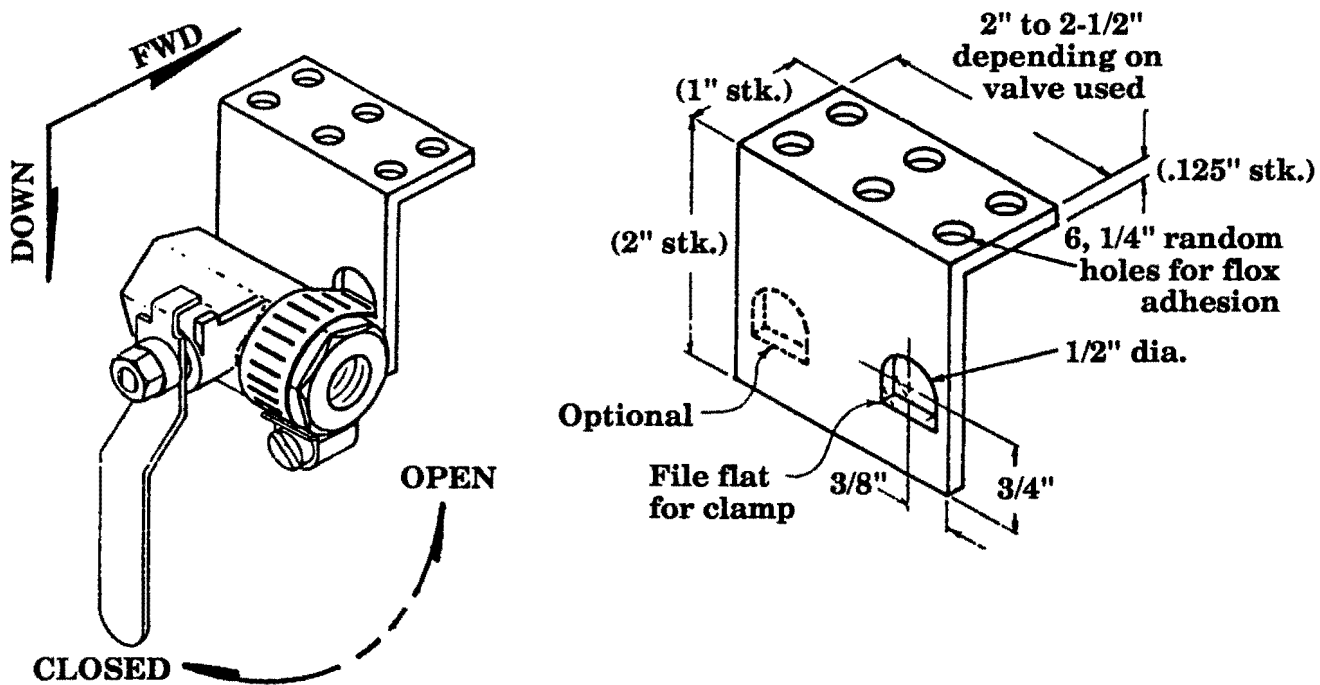

3. To locate the attachment area (for the mounting bracket) on the bottom of the header tank: measure approx. 7" outbd from the center line along the aft edge, start at this point and mark a rectangle that extends 6" outbd x 4" fwd. Sand the gel-coat off around this area. Be very careful to only sand the gel-coat, do not sand into the tank "glass" itself.
4. Clean and rough sand the base of the "L" bracket (top & bottom) where it is attached to the header tank. Immediately flox the base (pushing it through the holes) and press it in place with the back of the "L" bracket near the aft edge of the header tank. Smooth the flox to form fillets around the edges.
5. Apply 4 BID over the base of the "L" bracket while the flox is still wet. The BID shall extend 1-1/2" all around. Allow to cure completely.

6. Clamp the Main Shut-Off Valve to the "L" bracket with the handle in the "CLOSED" position, then work the valve handle to be sure there is no interference. Also tend to any sharp corners that may need filing.
7. Insert the finger strainer into the fuel tank fitting block.
8. Next install the AN822-6D elbow into the finger strainer.
9. Install 2 AN816-6D (nipples) in the Main Shut-Off Valve, one each side.
10. Install AN818-6D and AN819-6D (coupling nut & sleeve) to the fuel line ends as you route the aluminum tubing as shown in figure 11-16.
11. Fit the aluminum line to the tank such that it runs down the vertical face of the firewall. At this point you will need to refer to chapter 21 for the "Firewall Fwd" to complete the fuel system installation fwd of the firewall.



11-37

Chapter 11	REV.	0 / 11-1-91
FUEL SYSTEM		

N. Wing tank connections

The fuel from the outbd wing tanks will be transferred to the central header tank via one electric fuel transfer pump for each wing tank, thus two transfer pumps will be installed. These transfer pumps are generally installed under the seats. They are standard with all Lancair 320 kits.

1. First, make two 1/4" thick plywood base plates that anchor the transfer pumps down to the floor, see figure 11-18. Each plate will require two AN3-5A bolts or MS24694-S52 screws. Pot (bond) the two AN3 bolts into the plywood from the bottom side using epoxy/flox and allow to cure.

NOTE: Many builders have reported excellent installations of the transfer pumps into the aft portion of the stub wings.

Mount Plate - Fuel Transfer Pump
(typical mount plate for composite surfaces)
Figure 11-18

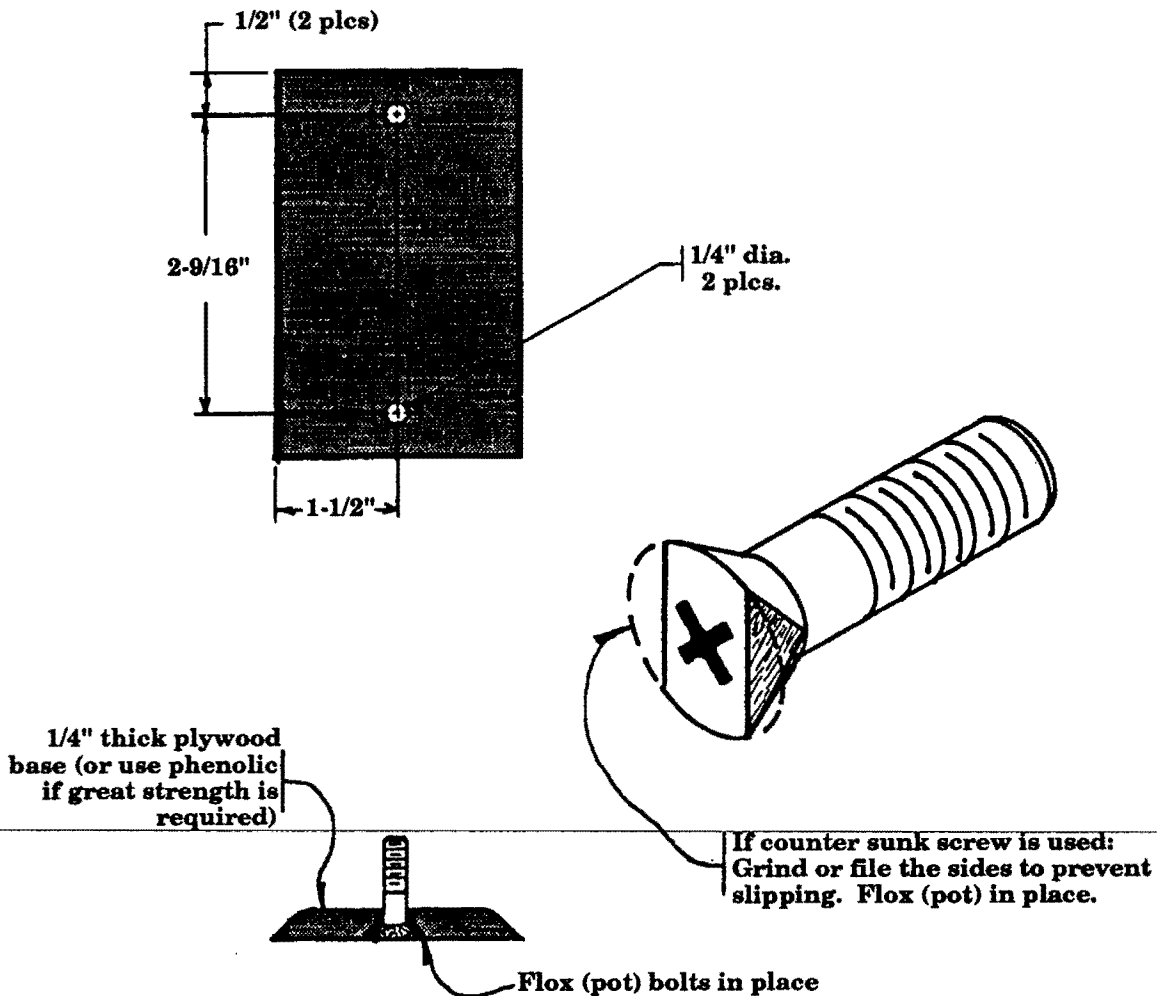

2. Using epoxy/flox again, pot the plywood plates down onto the floor in proper position and apply 2 BID over the top (wrap the bolt threads with plastic tape to protect them). Contact 1" onto the bottom pan, all around the plate. See figure 11-19.
3. Install the right and left fuel transfer pumps on the mount pads with elastic stop nuts (AN365-1032). Be sure that the flow direction of each pump is inboard (the arrow on the side should point to the center of the airplane).

Fuel Transfer Pumps - Installation

Figure 11-19

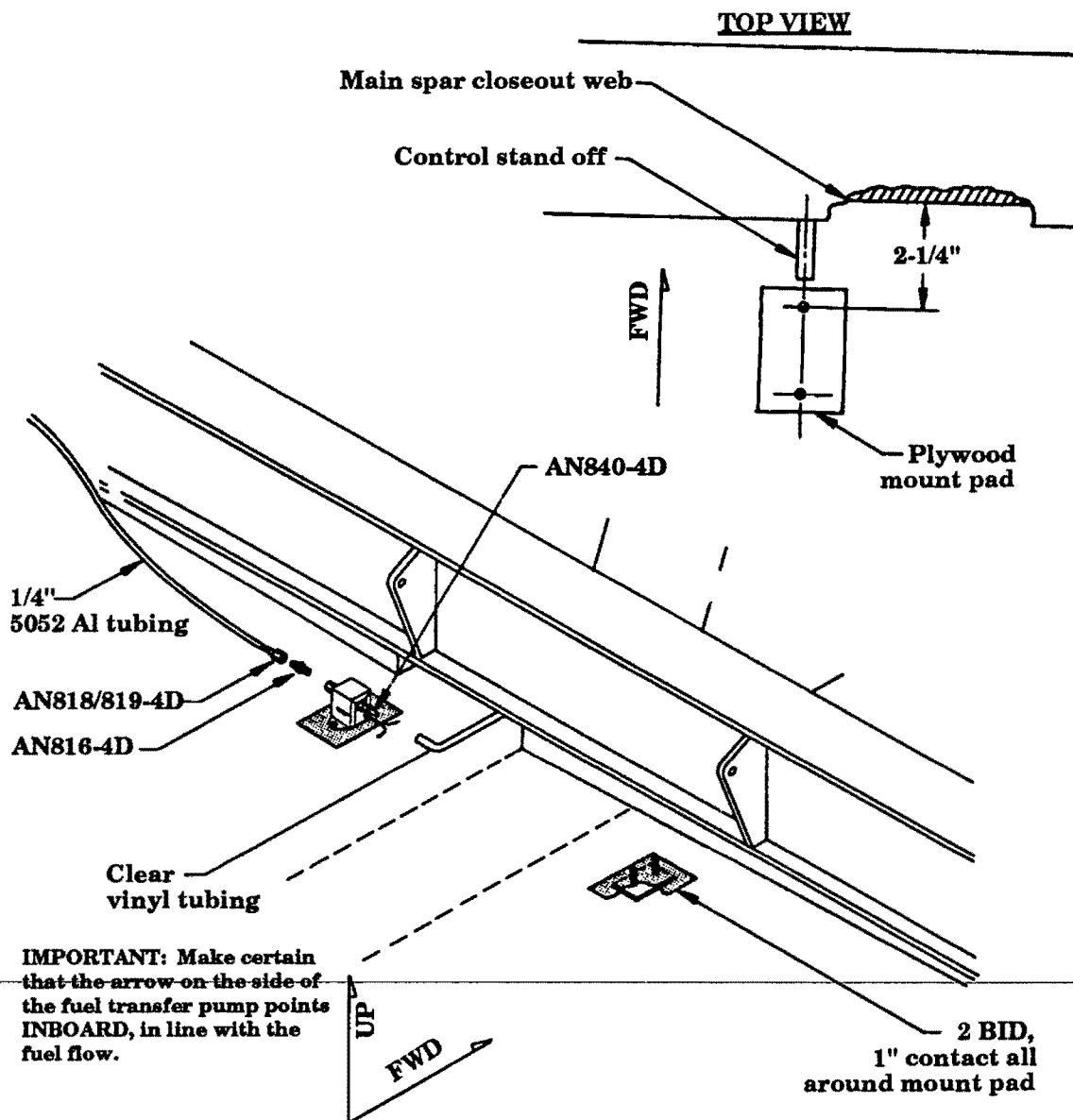

4. With the outboard wings completed, the aluminum line will route through BL 50 rib, behind the primary phenolic support brace for the main gear GM-4, and terminate 3" outboard of the secondary attach point for GM-4. This will place the flextube connection between GM-4 and the vertical spar face. From this point the fuel line must now be continued.
5. Here a 6" long piece of flexible tubing will serve as a connector between the two aluminum lines. The aluminum line should have a very slight flare put on both ends to facilitate a tight seal, do not put a full flare though since it will not allow the flex hose coupling to slip over it. Tighten hose clamps on each end. See figure 11-20.
6. Next route the aluminum line from a point 2-3" from the end (in the stub wing area) through the cockpit closeout rib and to the "in" side of the electric fuel pump, see figure 11-20.

Fuel Line Routing - Stub Wing Area

Figure 11-20

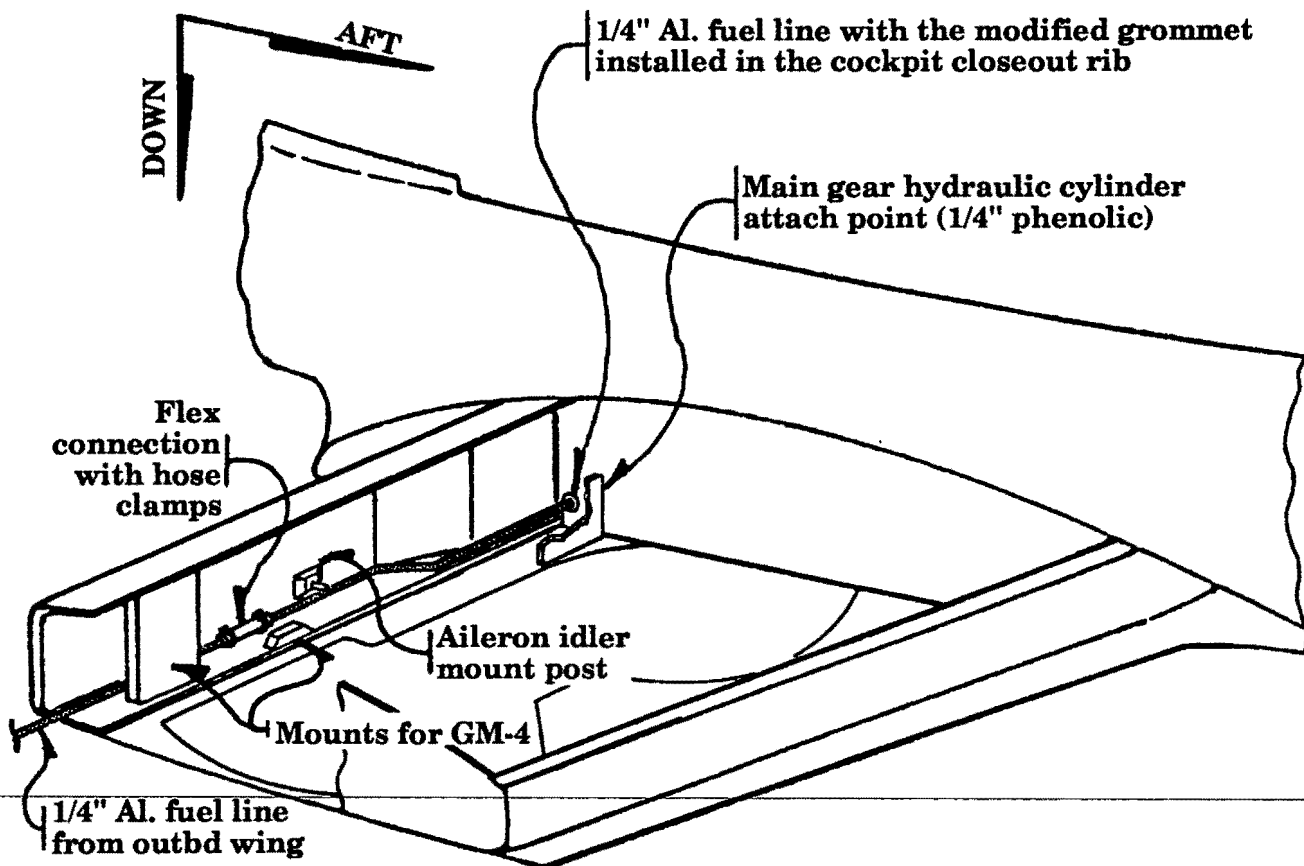

7. Where the line passes through the cockpit closeout rib, a rubber grommet or equiv. should be positioned to prevent any chance of chafing against the fiberglass of the rib. Most grommets are not designed to accommodate a thick bulkhead thus the following procedure can be used. See figure 11-21.
8. Trim off the flange from one side of the grommet (AN931-4-7) leaving the center portion with a flange on one side. This center portion will be 7/16" dia. Make two for each line.

Grommet Installation

Thick bulkhead modification

Figure 11-21

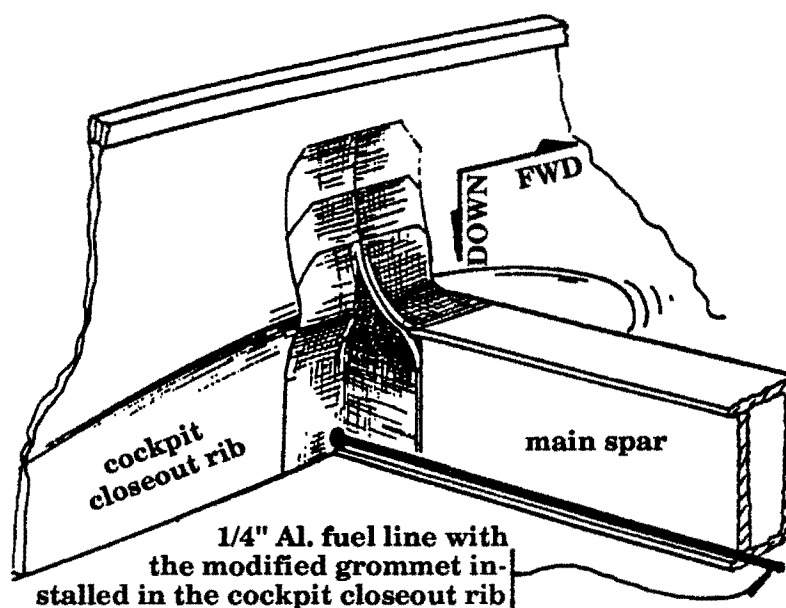

Trim off one flange
with Xacto knife,
toe nail clippers,
or small scissors

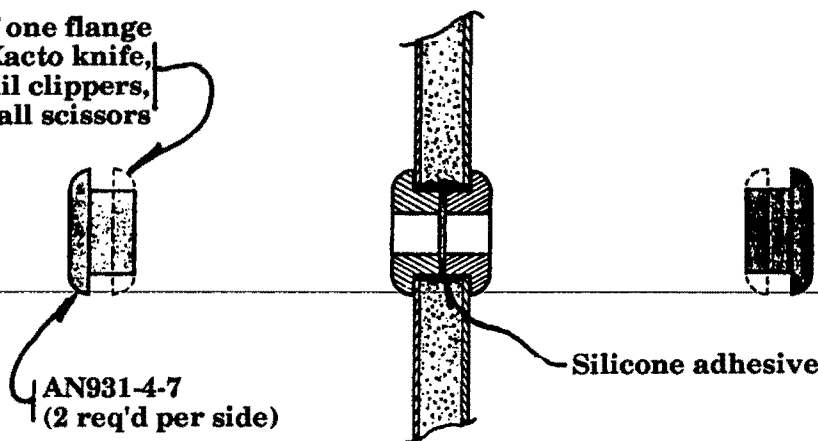

9. Drill a 7/16" hole through the bulkhead and use silicone to bond one grommet into the hole from each side. Allow this to cure about one hour. Next the 1/4" aluminum line can be slid through the grommets which will then provide an insulation from the fiberglass side walls. A little silicone on the tube where it passes through the grommet will assure a weather tight seal.
10. Check to make sure that the fuel line is not subject to any chafing, and is well clear of the gear well opening so that the gear and tire can not rub against it during cycling. The line can be secured down the airframe along its path by means of a simple clamp (MS21919-DG4). Secure the clamps to the composite surface with the same effective method used to mount the fuel pumps (pot a bolt into a piece of plywood, then floc and 2 BID it to the surface). These type of clamps have a rubber cushion around their perimeter to prevent any possibility of chafing.
11. Recheck the side of the fuel pump for a flow direction arrow, making sure that the line coming in from the wing tank is routed to the INLET side of the pump. Also be sure that your routing of the line stays clear of the hydraulic actuator.
12. Cut and flare the aluminum line (remembering, of course, to put the AN818-4D and 819-4D nut and sleeve on the line first), with a flare fitting, AN816-4D, in the fuel pump.

NOTE: Next, the line from the fuel transfer pump to the header tank must be installed. Many builders prefer to route this section of line using clear vinyl tubing and routing it such that the lines can be visually observed during flight to verify that fuel is indeed moving through the lines when the pumps are turned on. Also to verify when the tank runs empty so that the pump can be turned off. To accomplish this, the instrument panel must be installed so that an area along its console base can be used to expose a short portion of the clear line for visual observation.

13. If the line installation is to accommodate the above consideration, the instrument panel must be installed (see instrument panel installation, chapter 16). After that installation, insert the AN840-4D nipple fitting into the "OUT" side of the fuel transfer pump.
14. Locate a position on the side of the instrument panel/console base for the two fuel lines to allow observation, see figure 11-22. Cut the through holes in the panel and sand/file a smooth radius for the exit and insertion of the clear vinyl lines. **USE EXTREME CARE** to make sure that there are no sharp edges that could cut into the fuel lines. With a scrap piece of line, check the fit through the holes. Adjust as necessary. When the hole is properly fitted, it will take on an oblong appearance.



15. Route the fuel lines through this cutout, out through the sidewall, up the face approximately 3-4" and back through the panel sidewall. From there the line will extend upward to the fuel transfer ports on the header tank. This should not be installed until the panel is essentially installed, wired and completed.
16. Secure the line carefully so that there is no chance of any chafing. The line should also have a little bit of "slack" in it so as to not get stretched or receive a pull should the panel flex or shake with engine operation or passenger entry/exit, etc.

Visual fuel transfer indicator

(clear vinyl tubing)

Figure 11-22

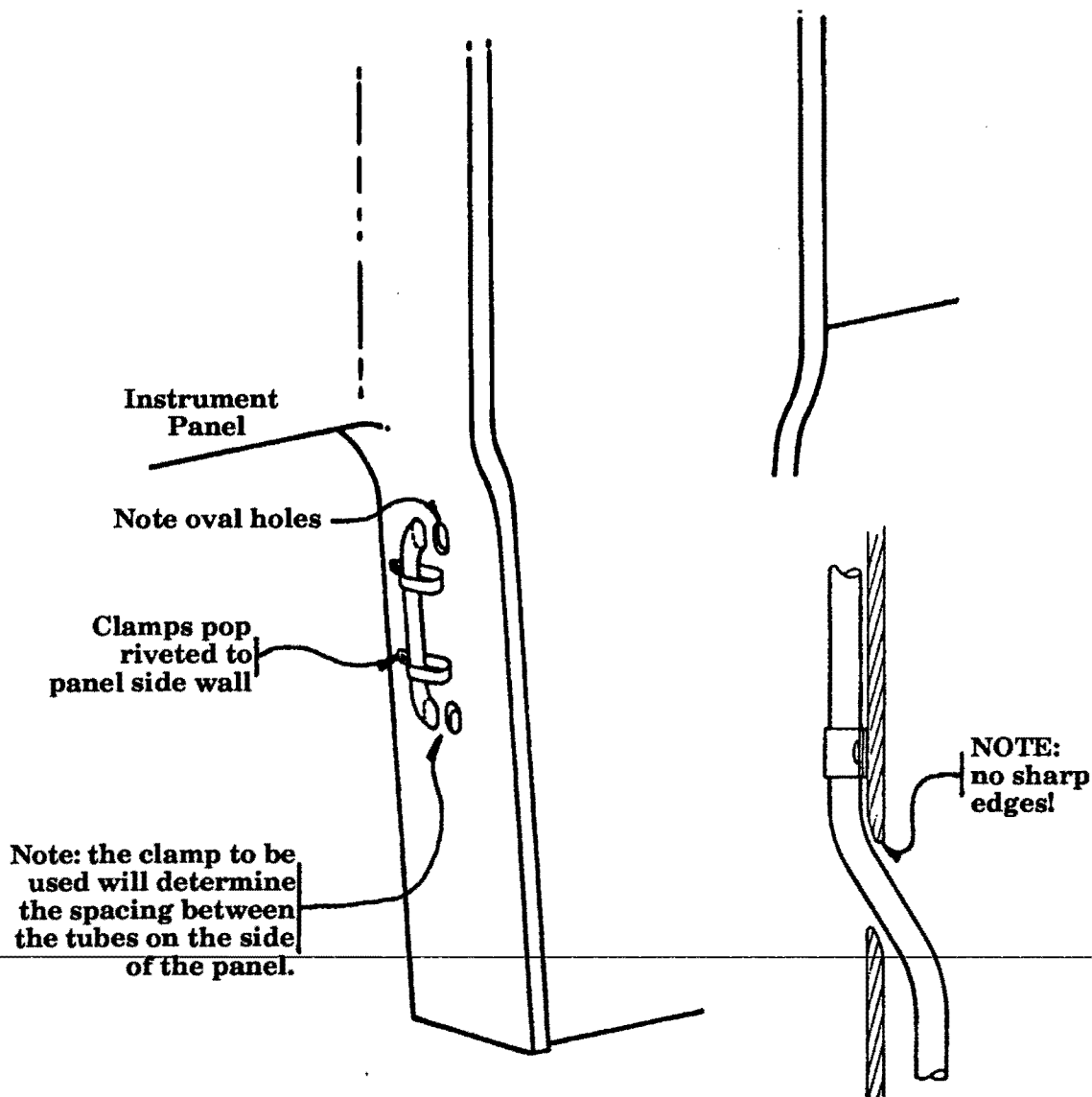

17. Note that the line will tend to bow out from the surface of the panel sidewall. This must be restrained and the line must be secured against the side of the panel sidewall. A small scrap of soft aluminum or equiv. can be cut and sized to nicely secure the line against the sidewall, see figure 11-23. Two small pieces like this will work well and provide a good looking installation as well. They can be pop-riveted to the panel sidewall after the panel is painted.

NOTE: It is acceptable to make a trial fit of these lines but do not permanently install them just yet. All the cockpit installation should be completed before these lines are permanently installed.

Restraints for Visual Fuel Transfer Indicator

(Clear vinyl tubing)

Figure 11-23

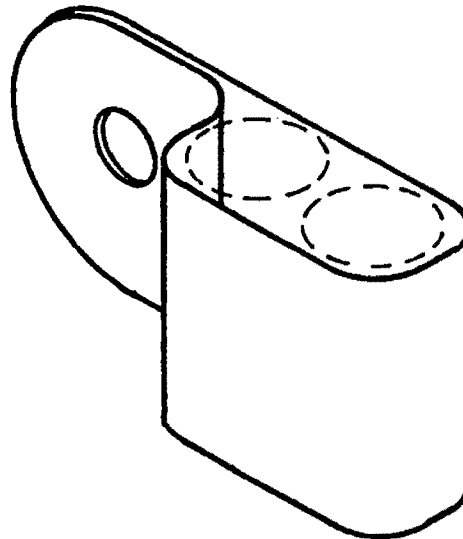

NOTE: The clamp to be used will determine the spacing between the tubes on the side of the panel.

Custom made aluminum clamp (2 required)

Two MS21919-DG6 clamps (min. 4 req'd)

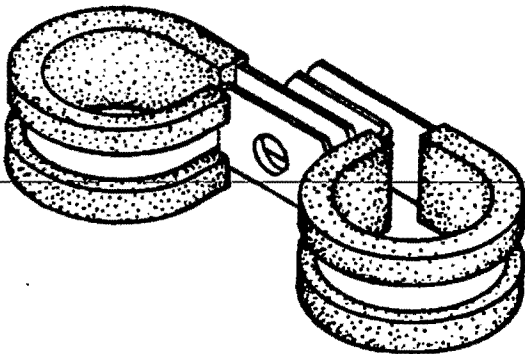

Forward deck installation

The fwd deck is now ready for installation. BUT, unless you are using on of the removable fwd deck methods, THIS SHOULD BE DONE LAST. After all systems and mechanicals are installed and double checked (just prior to final sanding and paint preparation). The permanent installation will be described here for future reference. IF YOU DON'T WAIT, YOU'LL BE SORRY!!

If you are installing either of the removable systems, they can be installed at any time from now on. A removable forward deck provides valuable access to service the instruments and mechanicals located in this area.

OPTIONS:

1. **The PERMANENT** installation is the simplest and provides a seamless finish, but lacks the advantage of access. The bonding is identical to joining the fslg halves.

2. **The HINGE MOUNT, REMOVABLE** method is used on the Company's red 320. Basically, it works by attaching the top of the hinge to the fwd deck and the bottom of the hinge to the fslg. The pin is cut long for a grab handle and is pulled out for removal of the fwd deck, then pushed back in when the deck is reattached. Externally it has a clean horizontal fit line showing no hardware (show quality finish), but it is the most complicated to install and can be difficult to reinstall if the hinge pin does not slide in and out with moderate resistance.

3. **The SCREW MOUNT, REMOVABLE** method works just like the cowl, it is very straight forward to install and is very easy to remove/reinstall, but has flush screw heads showing along the exterior fit line (just like the cowling).

O. **The PERMANENT forward deck installation**

The forward deck will attach in the same manner as joining the fslg halves.

1. Drill and cleco as you go, starting at the top center of the fire wall lip, work down to one corner, then from the top down to the other corner. Then work horizontally, from the firewall, aft. Locate the rivet holes, 2" apart, so that the same holes can be used for the upper cowl mounting.
2. Remove all clecoes and sand/clean the surfaces for adhesive. Apply structural adhesive to both the fwd deck and the fslg/firewall, where contact is made. Cleco the fwd deck to the fslg, using only the alignment holes at the corners.
3. Pop rivet the fwd deck/fslg following the same pattern as when installing the clecoes.
4. After adhesive has set, drill out all rivets and micro/epoxy all rivet holes and micro/epoxy fill along the horizontal fslg seam.



5. Sand the horizontal fslg joggles on both sides and apply 2 BID to the inside and out, (left and right). DO NOT APPLY BID TO THE JOGGLE WHERE THE COWL OR CANOPY FITS.



P. Forward deck installation hinge mount system

It is imperative to the proper operation of this mount system that the surface to which the hinge is to be mounted is smooth and consistent in its contour (the more straight it is the better it works), otherwise the hinge pin will bind when being inserted.

NOTE: Two electric drills will save a lot of time and frustration for this procedure, one for the 1/8" or 3/16" and one for the countersink. At times, each hole must be drilled, countersunk and riveted, before going on to the next hole. Use of a "micro stop, piloted, countersink" is highly recommended (this item is available from many aircraft parts suppliers).

1. Sand the old BID area inside of the joggle area above the longeron, where the fwd deck will attach (inside the fslg) with a block sander for a flat finish.
2. Apply 4 BID from the aft end of the joggle to the butt end of the old BIDs covering the fire wall brace, fire wall and vertical joggle, see figure 11-25.

NOTE: If the old BIDs are not straight after sanding, 2 additional BIDs may be necessary, covering the full length.

3. Before allowing the BID lay up to cure, cover two pieces of angle aluminum (1"x 2" works well) with wax or release tape and clamp it in place. Be sure that the angle piece used for the inside is taped so that there are no tape overlaps or bumps. One on the inside and one on the outside as shown in figure 11-26. Start at the fire wall and work aft, clamping as you go. The clamps on the old BID should be tight, while pressure on the remaining portion will need to be varied to achieve a visually consistent thickness. Allow this to cure completely before removing the clamps.
4. Sand to a flat, smooth contour.
5. The hinges must be prepared for installation. Refer to figure 11-27 for cutting, fitting marking and drilling instructions (as always, make a cardboard pattern first and check the fit). It is important to mark each hinge section on the inside; "upper left", "lower left", "upper right", "lower right" as is appropriate. This will eliminate confusion after the hinges are disassembled for installation.

IMPORTANT: The pin must be longer than the hinge, the extra length of the pin will be used to form the handle at the aft end (3-1/2" recommended). But do not bend the pin until installation is complete.

Forward deck installation, hinge mount system

Cross sectional view

Figure 11-24

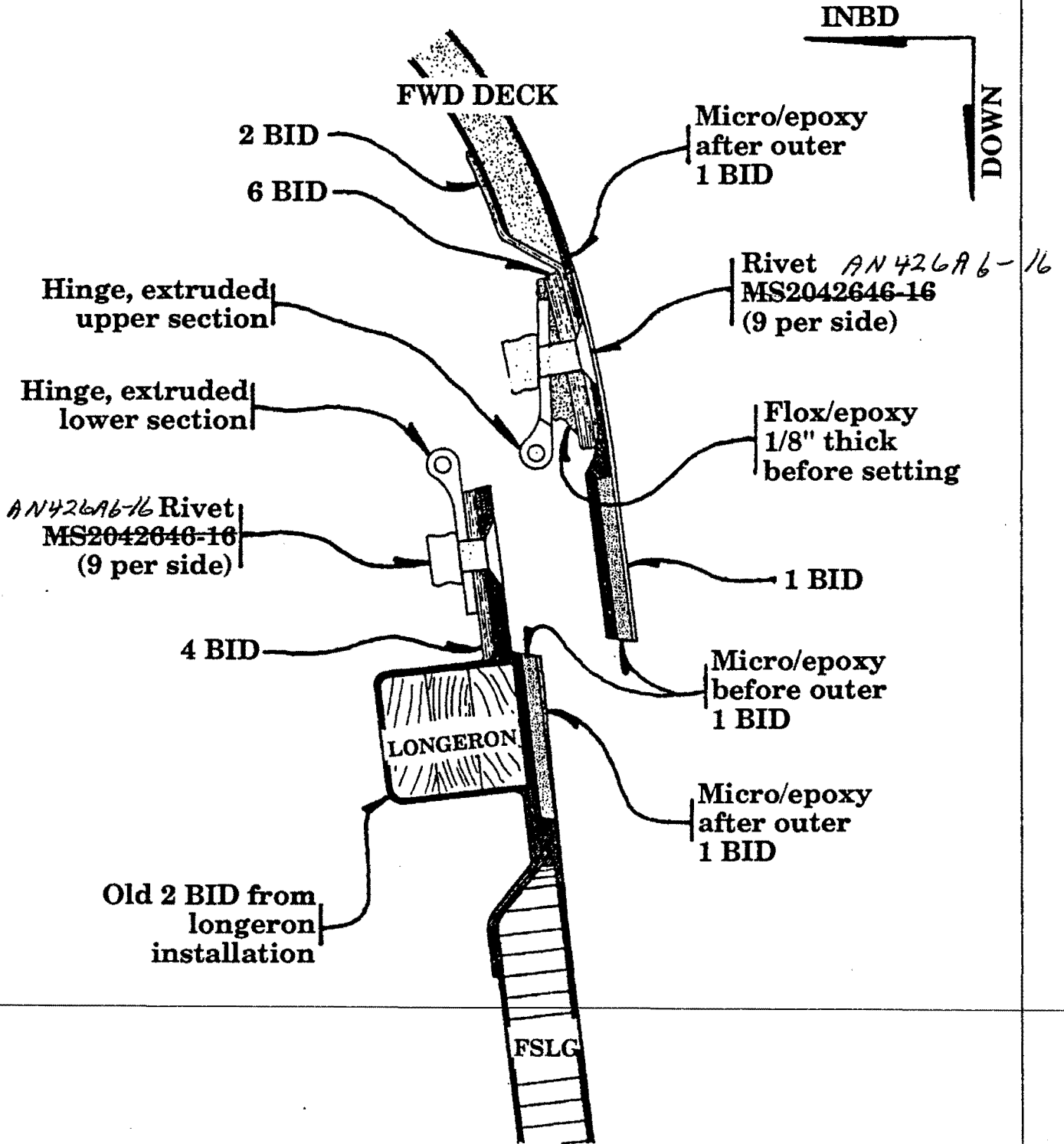

FSLG joggle preparation

Figure 11-25

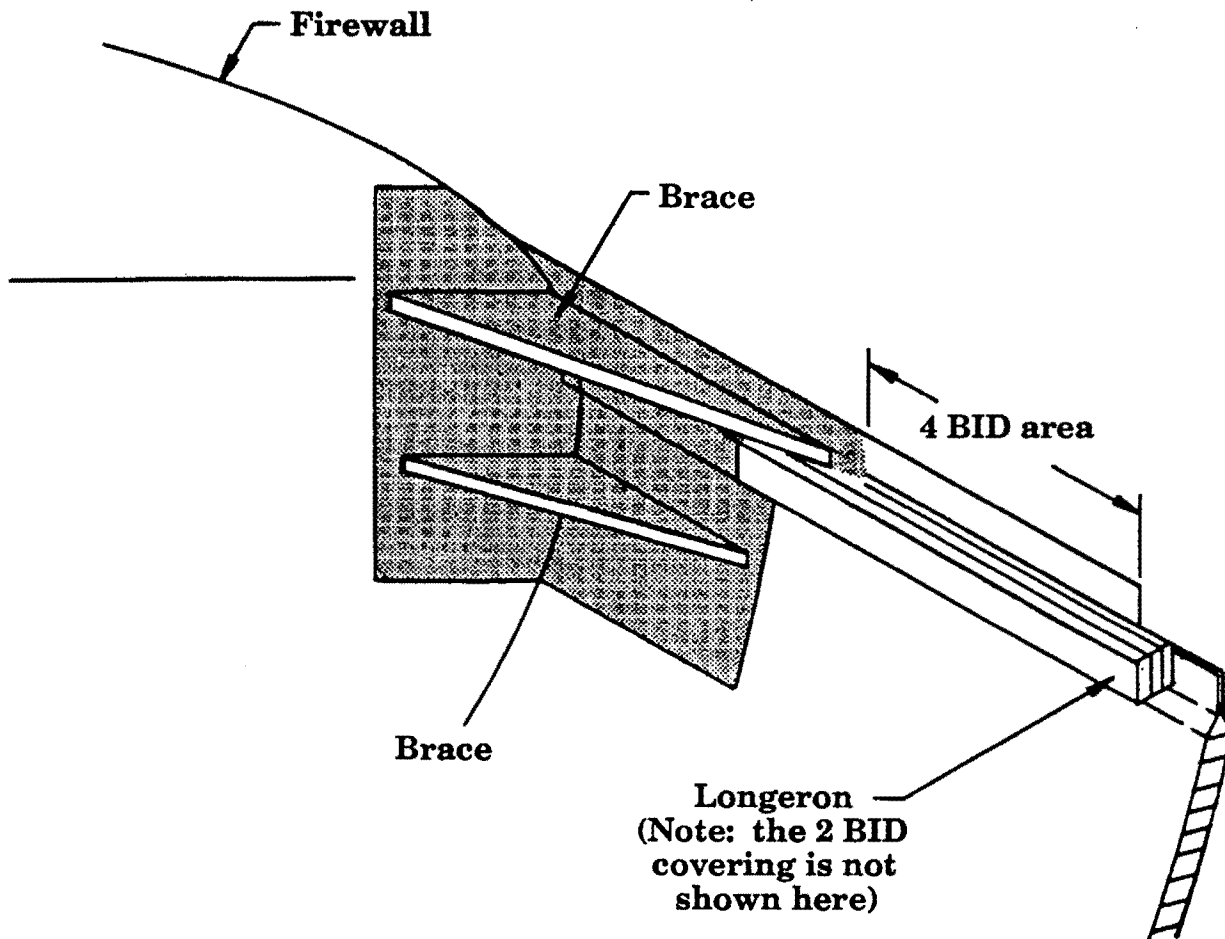

6. Disassemble the upper and lower sections of the hinge, set the upper section aside. Position the lower hinge section with the flat side against the BID (curve facing inboard). Trim the edge to fit around the brace with the hinge line just above the fslg joggle, see figure 11-28. File or sand all edges and corners smooth and free of burrs. Clamp in place with 4 clamps per side.

NOTE: If the alignment holes are covered by the hinge: drill through the original cleco holes and the hinge to re-establish fwd deck alignment. Remember not to rivet the alignment holes until after the upper hinge section is riveted to fwd deck, the fwd deck should be marked in the same manner (otherwise you will have to start all over again to align the fwd deck to the cowl/engine). Cleco the hinge through these holes and remove the clamps. If the alignment holes are out of the way and do not align with the hinge, they may still need to be drilled out due to the BID lay-ups.

ESLG JOGGLE PREPARATION

Clamping 4 BID lay-up

Figure 11-26

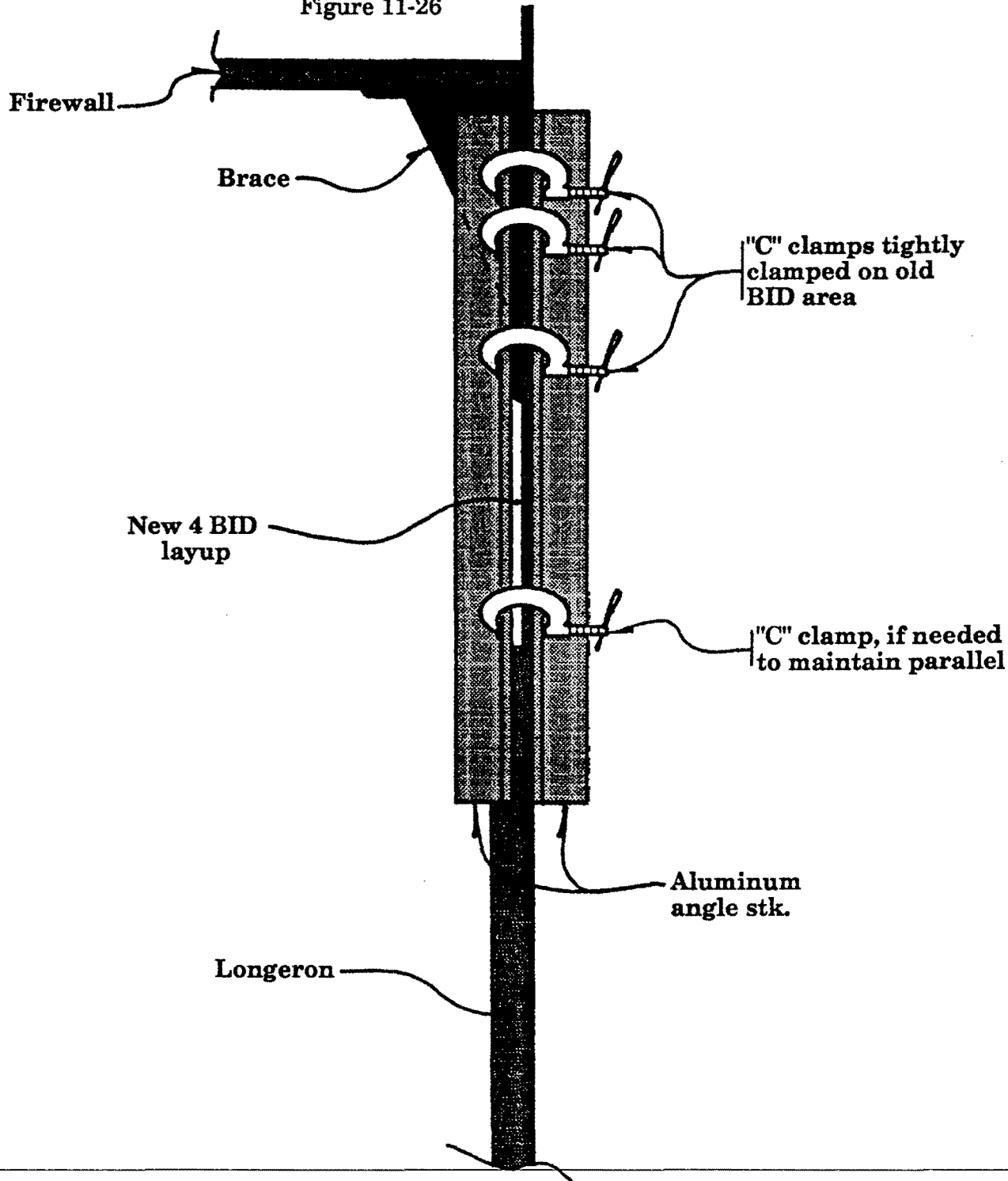

7. Starting at the fire wall, work aft. DRILL, COUNTER SINK, AND RIVET EACH HOLE BEFORE PROCEEDING TO THE NEXT. Drill 3/16" dia. hole from inside the fslg. Remove the clamps as you come to them. Counter sink from the outside of the fslg. Insert the rivet (MS2042646-16) from outside, and trim it so that it extends 1-1/2 times the dia. (9/32") beyond the hinge.

NOTE: DO NOT COUNTERSINK OR RIVET ANY OF THOSE SACRED ALIGNMENT HOLES YOU'VE GOT CIRCLED IN RED!

8. Install right and left lower hinge sections, before proceeding to the upper sections.
9. Taper the fwd end of the hinge pin with a file and sand it smooth to a slightly rounded point so that it will insert more easily. The pin will be used to ream the hinge, later. Apply oil to the pin now, in preparation for that process.
10. Assemble upper hinge to lower with the modified pin inserted from the aft end of the hinge. Flop upper hinge section inward for fitting of the fwd deck.
11. Cleco the completed fwd deck / header tank in place using those sacred original alignment holes that you circled in red.
12. At this point a recheck of the fwd deck/cowl alignment would be in order if you have any doubt about your original alignment. This would involve repeating the steps from page 11-7 through 11-10.
13. Hold the upper hinge section against the inside of the fwd deck and mark out the outline of the hinge (right and left).
14. Remove the fwd deck and place inverted on your work bench. Use a straight edge along the hinge line and continue the line all the way fwd and aft. Mark the ends as well so that the marks can be seen from the outside. Turn the fwd deck over and transfer the hinge line to the outside of the fwd deck, right and left sides (this marks the top of the upper hinge section).
15. Now back to the inside. The core material will have to be removed if it is within 1" of the hinge line so that the hinge will rivet to flat, solid, BID lay ups. Mark a BID area line 1" up from the hinge line, straight across. Grind away any core material or other surface irregularities within this area and sand to a smooth flat finish. Grind/sand the core material at an angle along the edge of this area for a smooth BID lay up transition, see figure 11-24.
16. Apply 2 BID to the hinge BID area, overlapping any exposed foam core by 1", then apply an additional 6 BID to just the flat area under the hinge, see figure 11-24.
17. Cleco the fwd deck in place, using the alignment holes.

HINGE PREPARATION

Mirror image - right and left sides
(two complete hinge sets required)

Figure 11-27

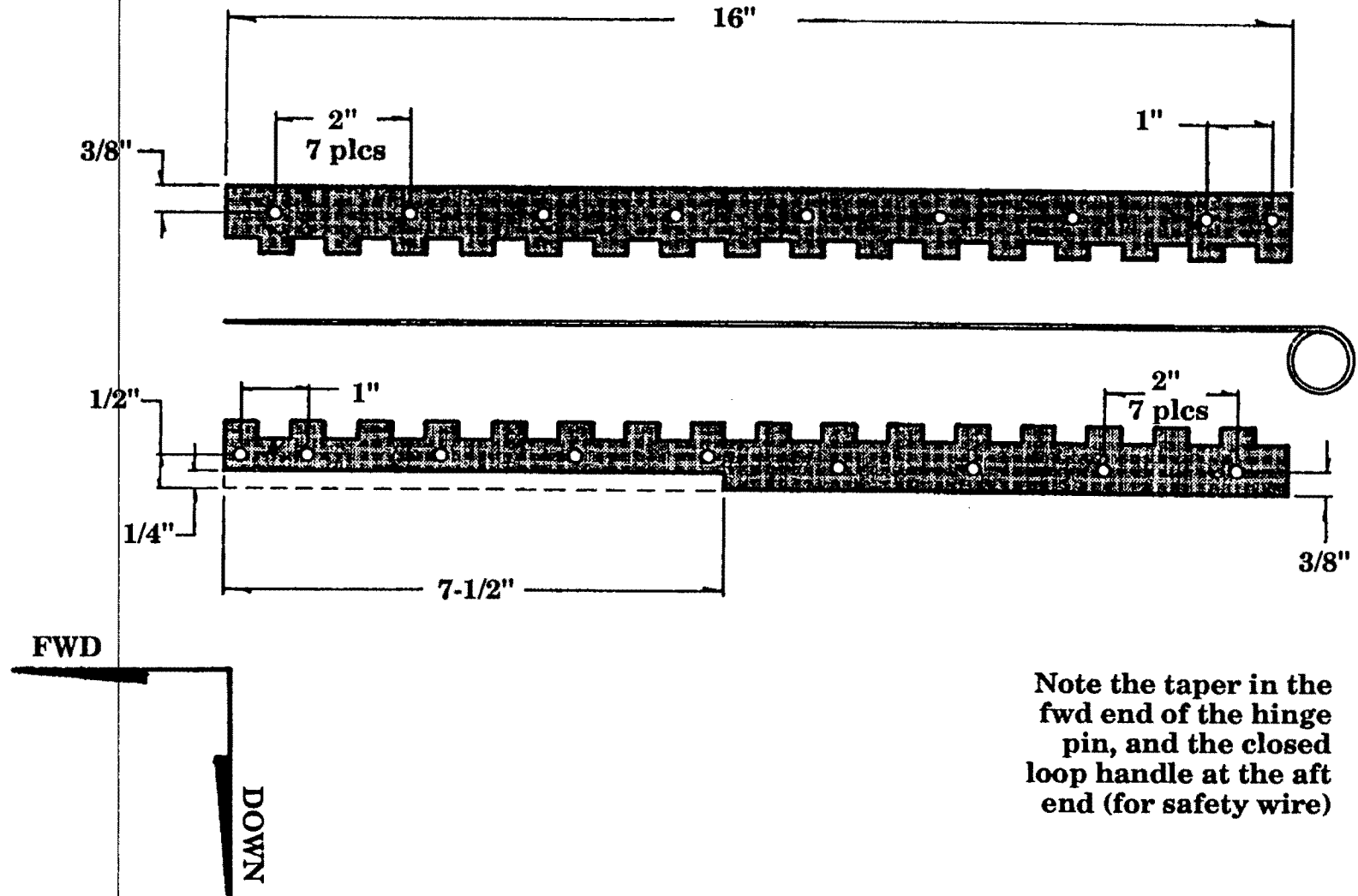

Note the taper in the fwd end of the hinge pin, and the closed loop handle at the aft end (for safety wire)





18. Now the upper hinge section will be attached to the fwd deck. **BE SURE TO CHECK YOUR LABELLING AND MATCH THE PROPER PARTS.** Use the "top of the hinge line" as a reference. Clamp the hinge in place at the aft end. Drill and cleco, 3/16" below the top edge of the hinge, start next to the clamp. Then drill/cleco in the middle, then the fwd end of each hinge, right and left.

19. Reach inside and re-mark the outline of the upper hinge section (right and left).

NOTE: The purpose of this method is to place the cleco holes at the top edge of the upper hinge section; (A) This will keep the holes out of the way of riveting. (B) And more importantly, this seats the upper hinge section against the fwd deck with a minimum of pressure, while maintaining alignment with the lower hinge section.

20. Remove all clecoes and remove the fwd deck leaving the upper hinge section attached to the fslg.

21. Apply release tape to the outside of the hinge joint and joggle area, as shown in figure 11-28. Sand and acetone or MC clean for bonding.

Upper hinge section - to fwd deck installation
Figure 11-28

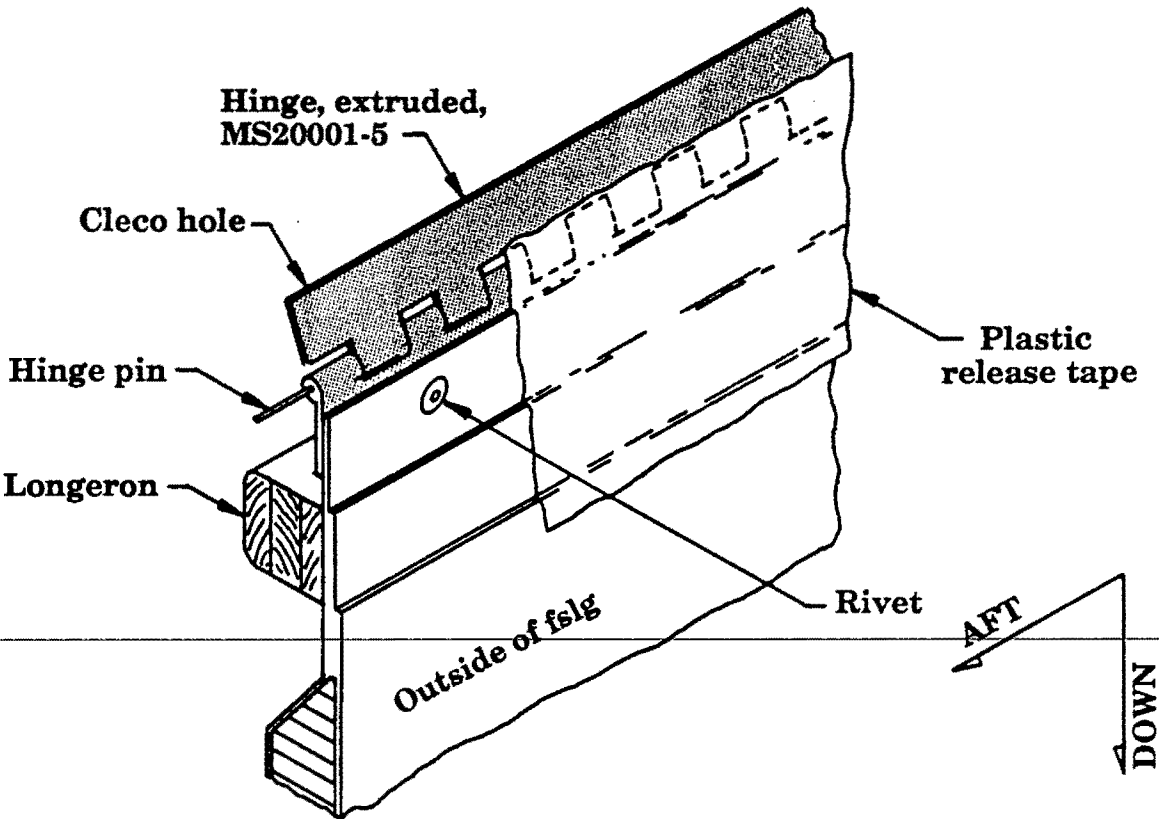



22. Apply "dry" epoxy/flox, 1/4" thick to the inside of the fwd deck with in the hinge outline (if the epoxy/flox is too "wet" it may crush when riveting). Mount the fwd deck to the fslg with clecoes in the red circled alignment holes. Press the upper hinge section against the fwd deck and cleco in place with waxed clecoes. Allow to cure completely.
23. Attach an electric screwdriver or similar rotary tool to the exposed, aft end of the stainless steel hinge pin, to ream smooth any possible bind points in the aluminum hinge. Slide the hinge pin in and out a few inches while it is rotating, continue until the non-rotating pin slides in and out with only slight to moderate pressure (it may be necessary to repeat this procedure several times, after the installation is completed).
24. Remove the hinge pin.
25. Now comes the test of straightness of your installation. Reinsert the hinge pin, a second set of hands might be necessary at this point... Moderate pressure may be required, but be very careful not to bend it (if the pin is bent it must be discarded, and a new one made). Banging on the fwd deck, while continuing to push, helps when the pin binds.

NOTE: Some of the existing installations required an amazing amount of reaming, banging, pushing and cursing to get the pin inserted. But the owners still feel that it is worth it, considering how infrequently the fwd deck will be removed after the plane is completed (if this is the case for you, those alignment holes and clecoes are the recommended temporary attachment).

NOTE: At this point, if the installation is hopelessly misaligned, it is time to try something else. Remove the hinge pin, leaving the fwd deck attached by the clecoes. Check the fwd deck alignment, if the hinges are impairing a good fit, at least the lower hinge section will have to be removed. Drill out the rivets and pry the hinge off. If your mistakes are evident to you, and you feel that they are correctable, then you may wish to start over.. If you still wish to have a removable fwd deck, the screw mount method is very straight forward, and the existing holes in the lower hinge section might be usable. If the holes must be filled, do so with epoxy/flox and avoid them completely. If all else fails, there is always the permanent installation which hides all goofs.

26. Remove all clecoes. Pull the pin from the hinge. Remove the fwd deck, with the upper hinge section attached, and place it on the workbench.

27. Lay out and center punch the hole locations on the hinge. Mark in red, the aft most hole location, for a safety wire tab (This is a reminder, do not rivet this hole; yet).



11-54

Chapter 11

REV.

0 / 11-1-91

FUEL SYSTEM





28. Now the upper hinge section will be riveted to the fwd deck in the same manner as the lower hinge section. Starting at the firewall, work aft **ONE RIVET AT A TIME**. Align the drill, perpendicular to the outside of the fwd deck (not the angled surface of the hinge), this will position the countersink heads as flush as possible. Drill 3/16" dia. holes, countersink the rivet holes, from outside the fslg. Insert the rivet (MS2042646-16, 3/16" x 1") and trim it so that it extends 1-1/2 times the dia. (9/32") beyond the highest point of the hinge. **ONE HOLE AT A TIME - DO NOT DRILL THE NEXT HOLE UNTIL THE PRECEDING HOLE HAS BEEN RIVETED.** Drill and countersink the aft most hole, but do not rivet it yet.

**Safety wire mount tab
(2 required)**

Figure 11-29

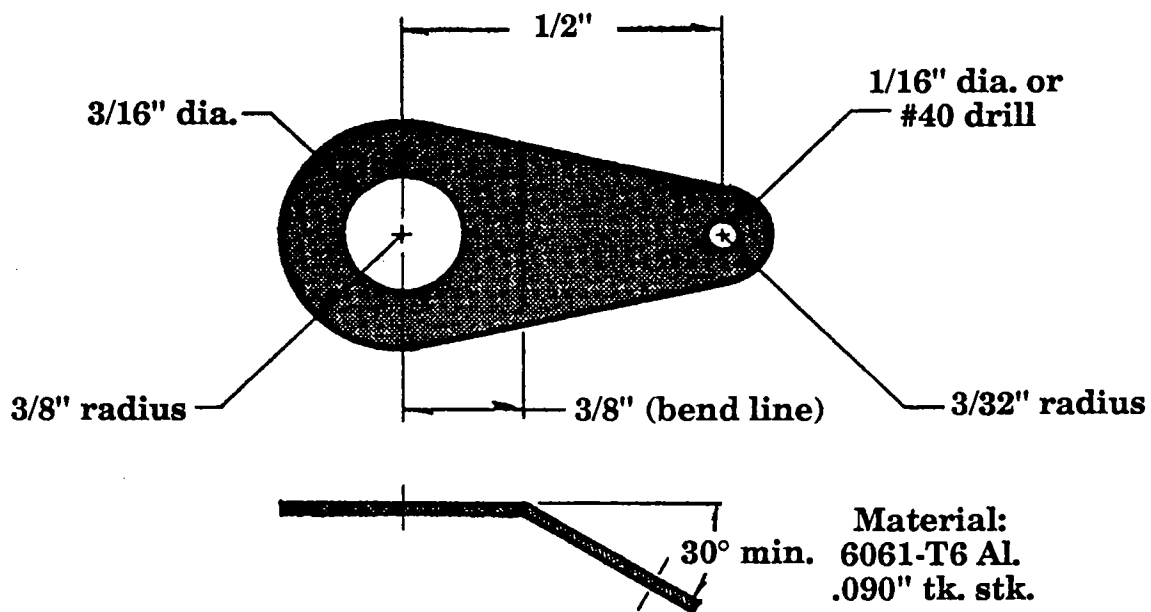

29. Insert the final, aft most rivet in the fwd deck through the upper hinge section. Slide the finished tab over the rivet with the wire hole pointed aft and bent inbd. Trim the rivet to 9/32" extension and compress (left and right).
30. The hinge pin must now be modified. There should be at least 3" excess pin length when the hinge is assembled to form the handle. Assemble the hinge and mark the pin to show where the hinge starts.
31. Use a vise with aluminum or brass jaw covers to protect the pin. Clamp the pin in the vise with the hinge start mark 1/4" from the vise. Use needle nose pliers to roll the excess pin in a tight circle. Be sure that a safety wire will not be able to come loose from the handle. Welding it is the safest way.





32. Reinstall the fwd deck, with the modified pin.
33. Epoxy/micro fill the entire upper and lower joggle area. Use a utility knife to separate the FWD DECK FILL from the FSLG FILL (run the knife along the bottom edge of the fwd deck joggle). Cure and sand smooth, repeat as necessary.
34. The rivet heads should be covered with 1 BID, to prevent the rivets from showing through the paint due to heat expansion. This BID should be 2" wide, starting at the bottom edge of the fwd deck, see figure 11-24.
35. Again epoxy/micro fill the lower fslg joggle and over the 1 BID on the fwd deck. Sand to a smooth fit, see figure 11-24.

The hinge mount installation is complete.



Q. Fwd deck installation - screw mount system (Optional)

Due to the firewall brace on the longeron, the nut plates will need to be placed near the top of the fslg joggle. Use of a "micro stop, piloted, countersink" is highly recommended for this installation (this item is available from many aircraft parts suppliers). A total of 4 BID must be added to the fwd deck joggle where the countersunk screw heads hold it to the FSLG. **DO NOT APPLY BID TO THE FWD COWL/FIREWALL JOGGLE OR TO THE AFT CANOPY JOGGLE.** This installation will be started with the fwd deck placed on the workbench, inverted. All directional references apply to the "normal", installed, position.

**Fwd deck installation - screw mounted system
cross sectional view**

Figure 11-30

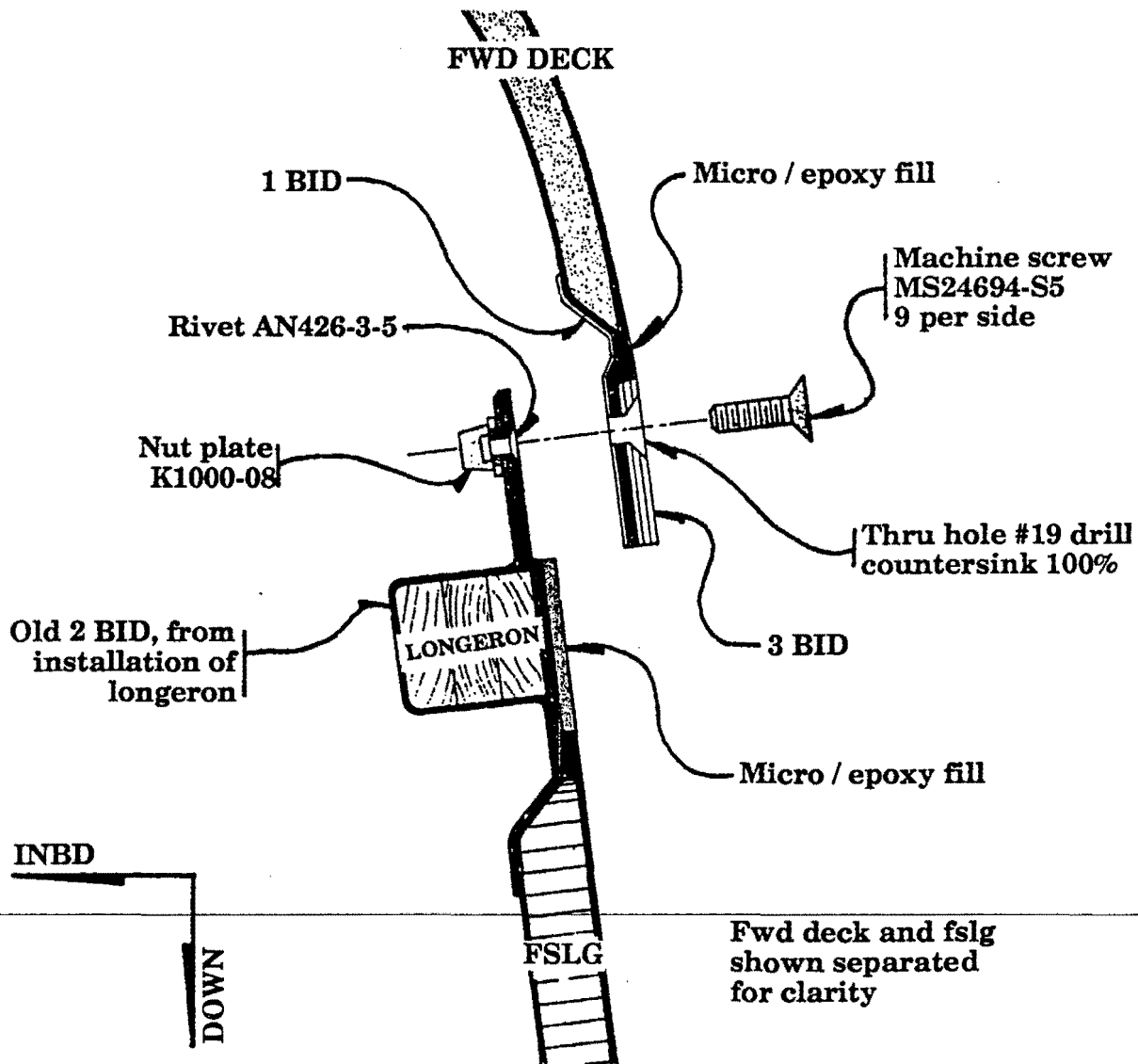



1. Prep the fwd deck joggle area, inside and out (sand - 24 grit & clean). Right and left sides.
2. Apply 1 BID (2" wide x 17" long) to the inside of the fwd deck joggle. Allow about 1/4" to overhang the bottom edge of the joggle. Trim this flush when the BID is green (right and left sides).
3. Apply 3 BID (2" wide x 17-1/2" long) to the outside of the fwd deck joggle. Butt the BID against the top of the joggle step, and allow any excess to overhang the bottom edge of the joggle. Trim this flush when the BID is green (right and left sides). Allow all BIDs to cure while working on the receiving joggle on the fslg.
4. Lightly sand the top edge of the fslg joggle straight and parallel to the lower edge of the joggle, this will be your reference plane.
5. Now establish the screw centers. Mark a horizontal line 5/16" below the top of the fslg joggle, all the way fwd and aft, and onto the ends of the joggle (be sure that the end marks will be visible with the fwd deck mounted).
6. Mark a vertical line 3/4" aft of the interior face of the firewall, then mark at 2" intervals to a total of 9 vertical marks (spanning 16" total). Run these lines down past the joggle, onto the fslg (so they can be seen with the fwd deck mounted).
7. Cleco the fwd deck in place and transfer the horizontal and vertical lines to the outside of the fwd deck.
8. This establishes the center for the nut plates. Drill these holes with a #9 drill bit.
9. Countersink the holes in the fwd deck (100°).

NOTE: The installation of the nut plates along the cowl joggle will be covered during the "COWL INSTALLATION".

10. Remove the fwd deck and set aside.
11. To insure alignment while drilling; (A) use a "nutplate drill guide", they cost about \$30.00, or (B) use the following steps.
12. Use a spacer that will not get in the way of riveting, such as a 1/4" length of 1/4" dia. tubing, with the end that will go against the fslg sanded/filed flat and dull. Insert from the outside, the MS24694-S5 screws through the spacer, fslg joggle, and the K1000-08 nut plate. Carefully tighten all of the nut plates snug, against the inside of the fslg joggle (too much pressure and the tubing will cut through the fslg). Align all the nut plate rivet holes horizontally.

NOTE: One side of each nut plate must be securely riveted before drilling the other side . Drill and rivet all right sides, then all the left sides.

13. Use the nut plate as a drill guide. Drill from the inside with a #40 bit.
14. Countersink the rivet holes, from outside the fslg joggle, for AN426-3-5 rivets (120°).
15. Rivet from the outside of the fslg joggle. Set (squish) each rivet to 5/32" (1-1/2 times the dia.).
16. Remove the screws and spacers. Mount the fwd deck and screw in place. Tinnerman washers may be used, loose or bonded to the fwd deck and painted.
17. Micro/epoxy fill the lower fslg joggle (if Tinnerman washers are bonded in, fill fwd deck to flush with the top of the washers). Sand to a smooth contour.

THE SCREW MOUNT INSTALLATION IS COMPLETE.

THIS CONCLUDES CHAPTER 11.

THE FUEL SYSTEM FWD OF THE FIREWALL IS COVERED IN CHAPTER 21.



11-59

Chapter 11	REV.	0 / 11-1-91
FUEL SYSTEM		

CHAPTER 12: RUDDER CONTROLS

REVISIONS

From time to time, revisions to this assembly manual may be deemed necessary. When such revisions are made, you should immediately replace all outdated pages with the revised pages. Discard the out dated pages. Note that on the lower right corner of each page is a "revision date". Initial printings will have the number "0" printed and the printing date. All subsequent revisions will have the revision number followed by the date of that revision. When such revisions are made, a "table of revisions" page will also be issued. This page (or pages) should be inserted in front of the opening page (this page) of each affected chapter. A new "table of revisions" page will accompany any revision made to a chapter.

Arrows

Most drawings will have arrows to show which direction the parts are facing, unless the drawing itself makes that very obvious. "A/C UP" refers to the direction that would be up if the part were installed in a plane sitting in the upright position. In most cases the part shown will be oriented in the same position as the part itself will be placed during that particular assembly step. However, time goes on and changes are made, so careful attention should be paid to the orientation arrows. That old cartoon of the guy agonizing over the plans for his canoe, built one end up, one end down, should not happen in real life. Especially to you.

CONTENTS

1. INTRODUCTION
2. DRAWING LIST
3. SPECIAL PARTS, TOOLS & SUPPLIES LIST
 - A. PARTS
 - B. TOOLS
 - C. MATERIALS & SUPPLIES
4. PROCEDURE
 - A. LEFT FOOT RUDDER CABLE (PILOT SIDE ONLY INSTALLATION)
 - B. RIGHT FOOT RUDDER CABLE (PILOT SIDE ONLY INSTALLATION)
 - C. COCKPIT SUB-FLOOR INSTALLATION
 - D. BRAKE CYLINDER AND BOTTOM MOUNT BRACKET INSTALLATION (FIXED POSITION)
 - E. ADJUSTABLE RUDDER PEDALS - PLYWOOD SLIDE PLATE SYSTEM
 - F. BRAKE CYLINDER AND BOTTOM MOUNT BRACKET INSTALLATION (ADJUSTABLE POSITION)
 - G. SUB-FLOOR HARD POINTS
 - H. CONTROL CABLE INSTALLATION
 - I. FINAL RUDDER PEDAL TO CABLE ATTACHMENT & ADJUSTMENT
 - J. RUDDER BAR TRAVEL & NEUTRAL POSITION
 - K. DUAL RUDDER CONTROLS (OPTIONAL)
 - PILOT SIDE - DUAL RUDDER CONTROLS
 - L. FINAL INSTALLATION - PILOTS SIDE RUDDER CABLES
 - M. ROUTING - PASSENGERS SIDE RUDDER CABLES

1. INTRODUCTION

The standard Lancair kits are supplied with pilot side rudder controls only. When flying the Lancair, rudder input is not normally required due to the differential ailerons. Some of our builders desire the rudder controls for the right side, they are available as an option. This chapter will discuss both, the standard installation and the "right rudder control option".

Rudder controls are via stainless steel cables. These cables are run through Nyla-Flow tubing as a guide through the fwd cockpit areas. Rudder pedal assemblies are attached to a sub-floor which will be installed adjacent to each side of the nose wheel well.

The standard installation is to permanently attach the rudder pedal assemblies to the fwd sub floor. An optional installation which allows for ground repositioning of the rudder pedal assemblies is also possible and will be shown.

READ THIS CHAPTER IN ITS ENTIRETY, BEFORE PROCEEDING WITH THE CONSTRUCTION.

Rudder Cables - Pilot Side Only

(Overhead view)

Figure 12-1

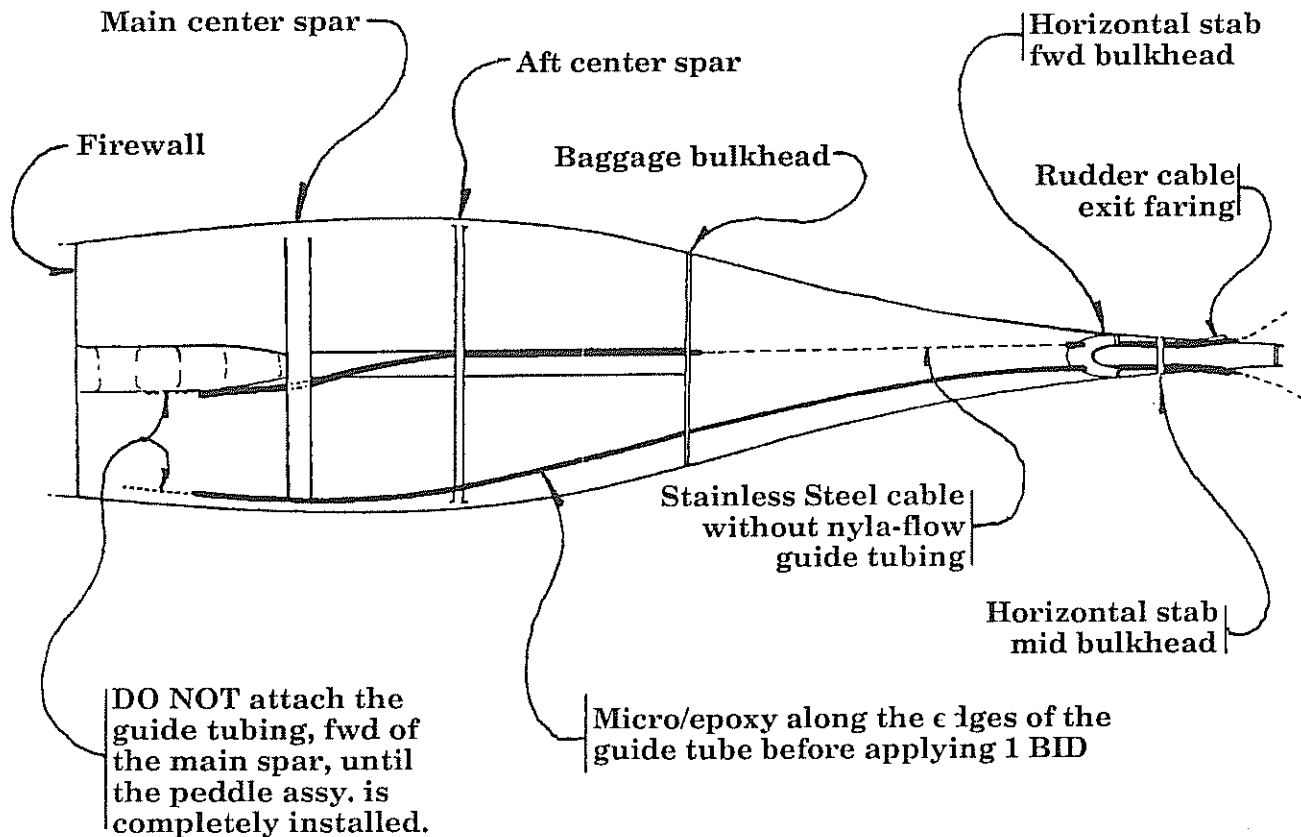

2. DRAWING LIST

Drawing	Page	Title
12-1	12-2	Rudder cables - pilot side only
12-2	12-7	Rudder cable exit faring
12-3	12-8	Right rudder guide tube
12-4	12-9	Rudder guide-tube routing
12-5	12-12	Guide tube - bulkhead exit
12-6	12-13	Cockpit sub-floor installation
12-7	12-15	Sub-floor hard points
12-8	12-17	Sub-floor reinforcement
12-9	12-18	Rudder pedal assembly - installation
12-10	12-21	Rudder pedal assembly
12-11	12-22	Rudder pedal system
12-12	12-23	Plywood slide plate
12-13	12-25	Plywood base plate
12-14	12-29	Rudder cable to control horn attachment
12-15	12-33	Rudder cable to pedal bar attach system
12-16	12-33	Brake / spring attach bracket
12-17	12-34	Dual rudder control system
12-18	12-35	Pilot side - dual rudder controls
12-19	12-37	Standoff / fairlead installation
12-20	12-38	Standoff pattern



3. EQUIPMENT REQUIRED - SPECIAL PARTS, TOOLS & SUPPLIES

A. Parts

- Rudder pedal assembly (supplied in kit, or 2, if passenger side is to be installed)

(Refer to list on page 12-19, and drawing 12-10 on page 12-20)

- Countersunk steel pop rivets (not supplied - for adjustable rudder pedal installation only - see page 12-26, step 6)
- Stainless steel rudder cable, with clevis on one end (supplied in kit)
- Stainless steel rudder cable, with thimble type termination (supplied in kit)



B. Tools

- Ruler or tape measure
- Dremel™ type rotary grinder
- drill motor
- drill bits: 1/4"
3/16"
#12
- Small level or Smart-Level, or compass for measuring degrees of elevation
- Pencil
- Some small weight bags - 5 to 10 lbs., 1 or 2.
- Rivet squeezers
- Bench vise
- Hammer
- Cold chisel, with about a 3/4" blade (see note, page 12-27)
- 2) C-clamps, small
- **NICO PRESS CRIMPER - NOT PLIERS - THEY WILL NOT DO.**



C. Materials & supplies

- epoxy
- flox
- BID cloth
- micro
- 3/16" Nyla-Flow tubing
- sandpaper, assorted grit
- some 1/4" plywood or similar (for adjustable pedal system only)
- Duct tape
- MC or acetone for cleaning
- 1/4" prepreg, foam core, 1 BID per side
- Cardboard for templates
- 3/4" PVC tubing (not supplied)
- Soundproofing material - refer to page 12-16 for details, suggestions
- 1/4" phenolic
- light springs - not supplied - see page 12-31, Note under step 10.



4. PROCEDURE

A. Left foot rudder cable

(Standard - pilot side only installation)

1. Select the rudder cable guide material (3/16" Nyla-Flow tubing). You'll need some means of temporarily attaching this tubing to the inside of the fslg until the fiberglass BID tapes are applied, a hot glue gun works very well for this purpose.
2. The left cable guide will run along the left side of the fslg from the small fairing under the horizontal stab area to approximately FS 15 which is just forward of the main spar (over the wing L.E. fillet). See figure 12-1. Be sure NOT to attach the guide tubing fwd of the main spar.

NOTE: Do not permanently attach or trim this guide tube (fwd of the load transfer pad) until the rudder pedal assembly is in position so that a good length and alignment check can be verified.

CAUTION: It is important to run the guide tubing in a smooth transition from fwd to aft along the fslg. If you were to route the guide tubing with sharp turns, the cable would tend to drag along those areas and resistance would increase. This increase resistance would tend to make the rudder control "heavy" and could induce cable guide wear.

The guide tubing will have to make some turns as it progresses along the inside contour of the fslg, but the point is to minimize these turns as much as possible.

Rudder cable exit fairing

Figure 12-2

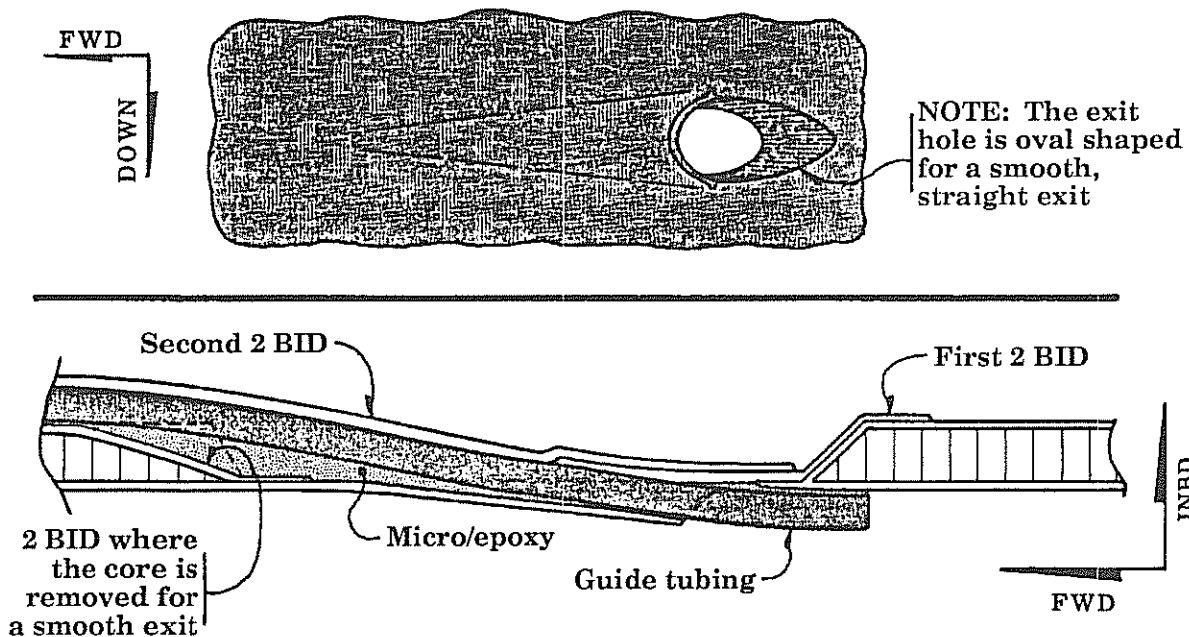

3. You can start at either the fwd or aft end, we'll start at the aft. Using a Dremel rotary tool or drill bit, open up a passage way through the end of the small fairing that sticks out from the side of the fslg, under the horizontal stab, just in front of the vertical post. Slip the rotary file into the hole and grind away slightly into the side of the fslg, aft of this fairing such to allow the tubing to make a relatively smooth transition from the inside of the fslg to the outside and back to the rudder control horn. See figure 12-2.
4. Moving fwd from the aft fairing, the guide tube must lay along the inside of the fslg and punch through the two horizontal stab bulkheads. A long (min. 12") 3/16" dia. drill bit will work for this purpose. See figure 12-3.

Right rudder guide tube

Interior view

Figure 12-3

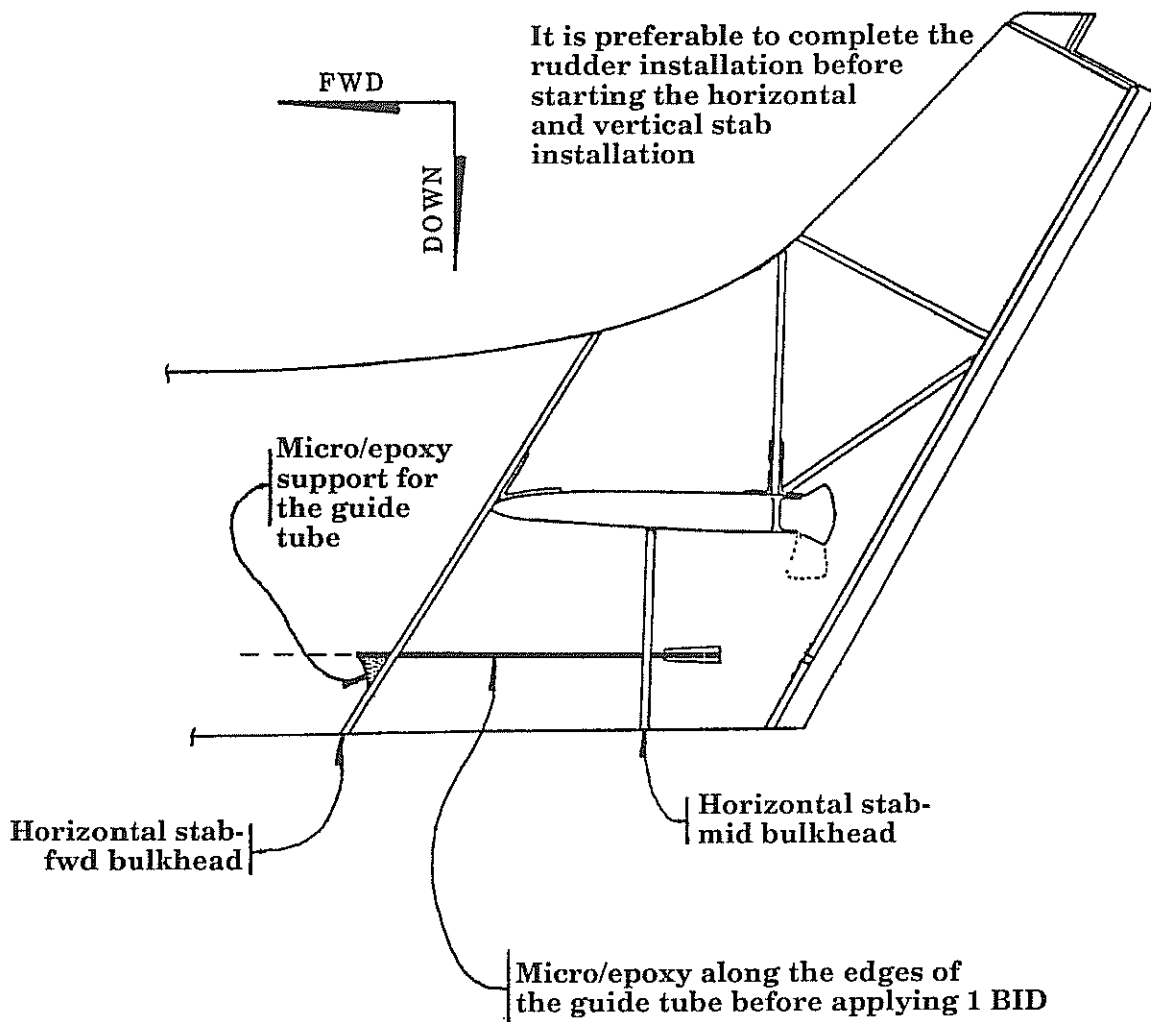

Rudder guide - tube routing

(Aft spar - fwd)

Figure 12-4

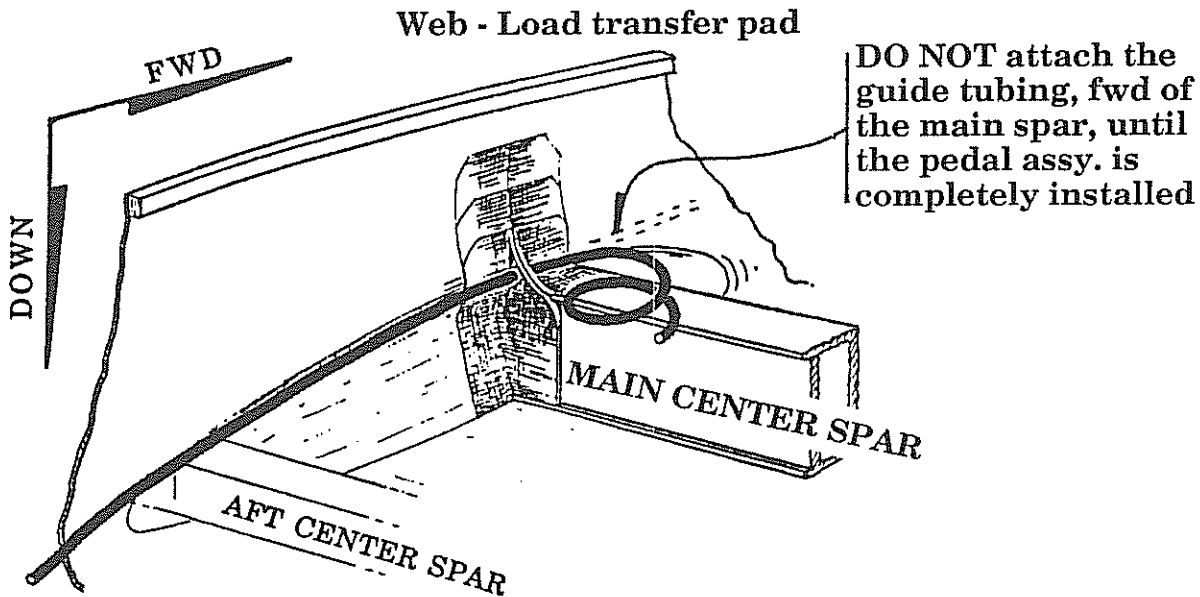

5. Route the guide tube fwd to the baggage bulkhead. See figure 12-1. The tubing then routes fwd along the side of the fslg and follows the upper contour line where the wing intersects. The line will thus route over the aft ctr spar and along the upper edge of the cockpit close out web. Where the load transfer pads are positioned, another 3/16" dia. hole is drilled to allow the tubing to pass through. It will then route fwd above the wing fillet "roll" and terminate at a point approximately in line with the wing fillet L.E. See figure 12-4.

NOTE: Do not permanently attach or trim this guide tube (fwd of the load transfer pad) until the rudder pedal assembly is in position so that a good length and alignment check can be verified.

6. With the line "roughly" routed through the fslg and in relative position, pull it smooth and inspect the overall path to assure that it is as smooth and kink free as possible. Use a few pieces of tape to hold it in position for this inspection.
7. With the guide tubing taped in position and verified to be in the most ideal flowing path from aft to fwd, use a hot glue gun to better fix its position. A dab of hot glue about every six inches will be sufficient.

8. With the guide tubing tacked in place with hot glue, rough sand around the line (about an inch on each side of the tubing). Make a micro/epoxy fillet along both sides of the guide tubing, sand again and apply a 1 BID tape over the guide tube line. This BID tape should be about 1-1/2" wide (once again, do not apply the 1 BID from the load transfer pad area - fwd. Wait until the rudder assembly is positioned so that you can check the alignment).
9. At the aft end, trim the Nyla-Flow guide tube flush with the exterior of the exit fairing.



12-10

Chapter 12	REV.	0 / 11-1-91
RUDDER CONTROLS		

B. Right foot rudder cable

(Standard - pilot side only installation)

The right rudder cable will install in a similar manner with a few exceptions. See figure 12-1.

1. Locate and install the guide tube through the aft fslg fairing as performed for the left side cable guide tube. See figure 12-2.
2. Route the cable fwd through the two horizontal stab bulkheads. The line need only extend fwd of the "fwd horizontal stab bulkhead" by about 6" where it will end (This is different from the left side installation which routed the guide tube all the way fwd to the baggage bulkhead). See figure 12-1.
3. Drill a 1/4" hole in the baggage bulkhead located 1/2" above the bottom and 1-1/2" right of center line (passenger side). This is where the guide tube will begin once again. Since the rudder cable is suspended in air from the baggage bulkhead aft to the first horizontal stab bulkhead, the guide tubing is not required along that distance. The guide tubing should extend about an inch aft of the back face of the baggage bulkhead.
4. From the baggage bulkhead location, route the tubing fwd along a line that is 1-1/2" right of the center of the fslg bottom. The tubing will attach to the floor at approximately FS 63. Thus from FS 63 to the bulkhead, the tubing will angle upward (off the floor) as it moves aft to the baggage bulkhead. This section of tubing will later be attached to the floor or side of the console extension that must be installed in the baggage compartment to isolate and protect the controls. Leave this section of guide tubing loose until the console extension sides are installed. From the point where the tubing attaches to the floor (FS 63), it can start to angle inward toward the actual center line of the fslg.

NOTE: This is important since the console in the cabin area will only be 1-1/2" wide and the guide tubing must fit inside of its 1/4" walls.

5. The tubing will route under the aft ctr spar, along the floor and under the fwd main ctr spar. Through this area, it will cross to the left of fslg center line. At the fwd face of the main spar, the guide tube will angle upward to the left side of the nose gear tunnel. See figure 12-1 and 12-9.

The tubing must attach to the left side of the nose gear tunnel at a height that aligns well with the mount hole on the rudder bar. Thus, do not attach the tubing to the nose gear tunnel until the rudder pedals have been positioned and an alignment check can be verified. See figure 12-9.

6. Tape the guide tube into position and again use hot or instant glue dabs every 6" to temporarily attach it to the fslg.



7. Next sand and clean an area extending 1" on each side of the guide tube, micro fillet along the tube, and add 1 BID ply over the tubing. Wrap a small piece of 1 BID around the piece of tubing that extends 1" aft of the aft face of the baggage bulkhead, and the similar piece of tubing on the fwd face of the horizontal stab L.E. bulkhead.

NOTE: It is advisable to route the actual cable through the guide tubing and pull it snug. This will require someone to hold it at the aft end while someone else pulls gently from the fwd end (or use clamps). With the cable pulled snug, note the relative angles at which the cable exits the guide tubing in the area between the baggage bulkhead and the fwd most horizontal stab bulkhead. The guide tubing should be anchored in a position that allows for a smooth exit and entrance of the cable. With a good entrance and exit established, use the 1 BID with micro (as a filling support) to lock in the desired guide tube termination points. See figure 12-5.

CAUTION: Failure to establish the above described smooth entrance and exit could result in excessive guide tube wear and possible malfunction of rudder control as a subsequent result.

Guide tube - bulkhead exit

Figure 12-5

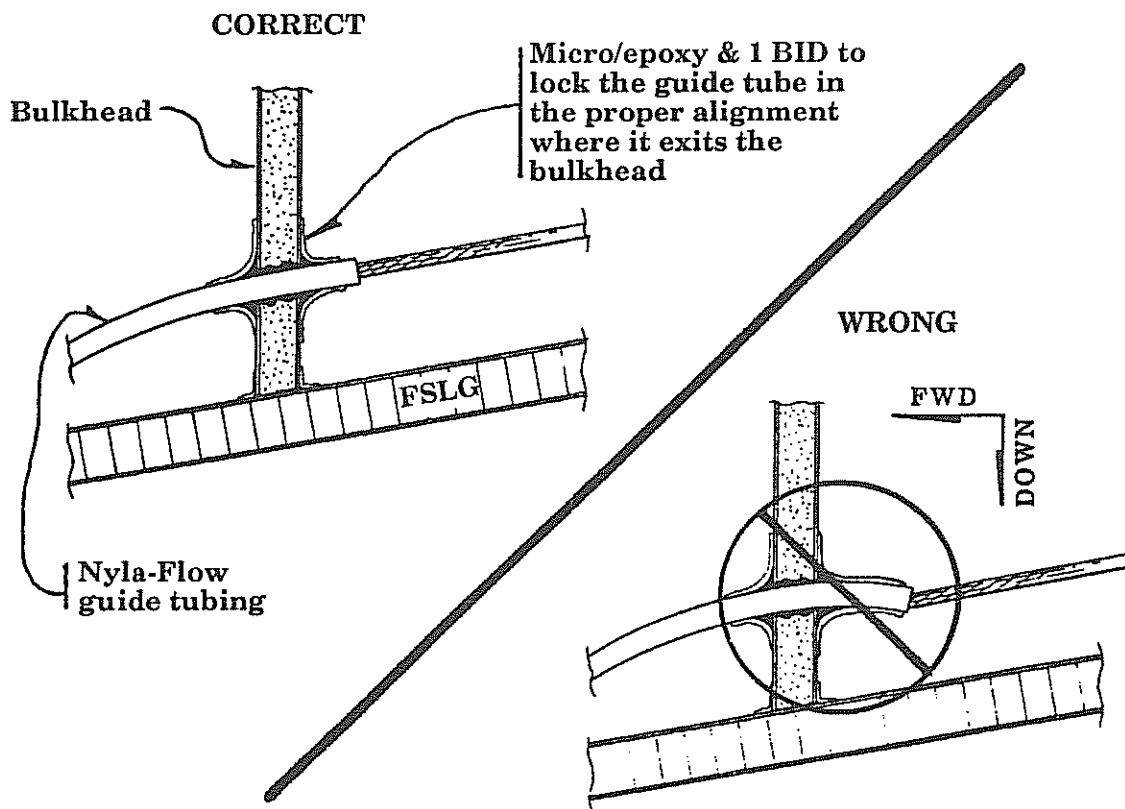

C. **Cockpit sub-floor installation**

The sub-floor is made of 1/4" foam core with 1 BID per side, additional BID will be applied later for stiffness. The sub-floor will extend from a point approximately 2" aft of the firewall, back to approximately FS 18 then angle down to the fslg bottom at about FS 21. These aft positions are at the builders discretion since they form an angle upon which your feet can rest during flight. These dimensions are generally acceptable and very comfortable.

Cockpit sub-floor installation

Figure 12-6

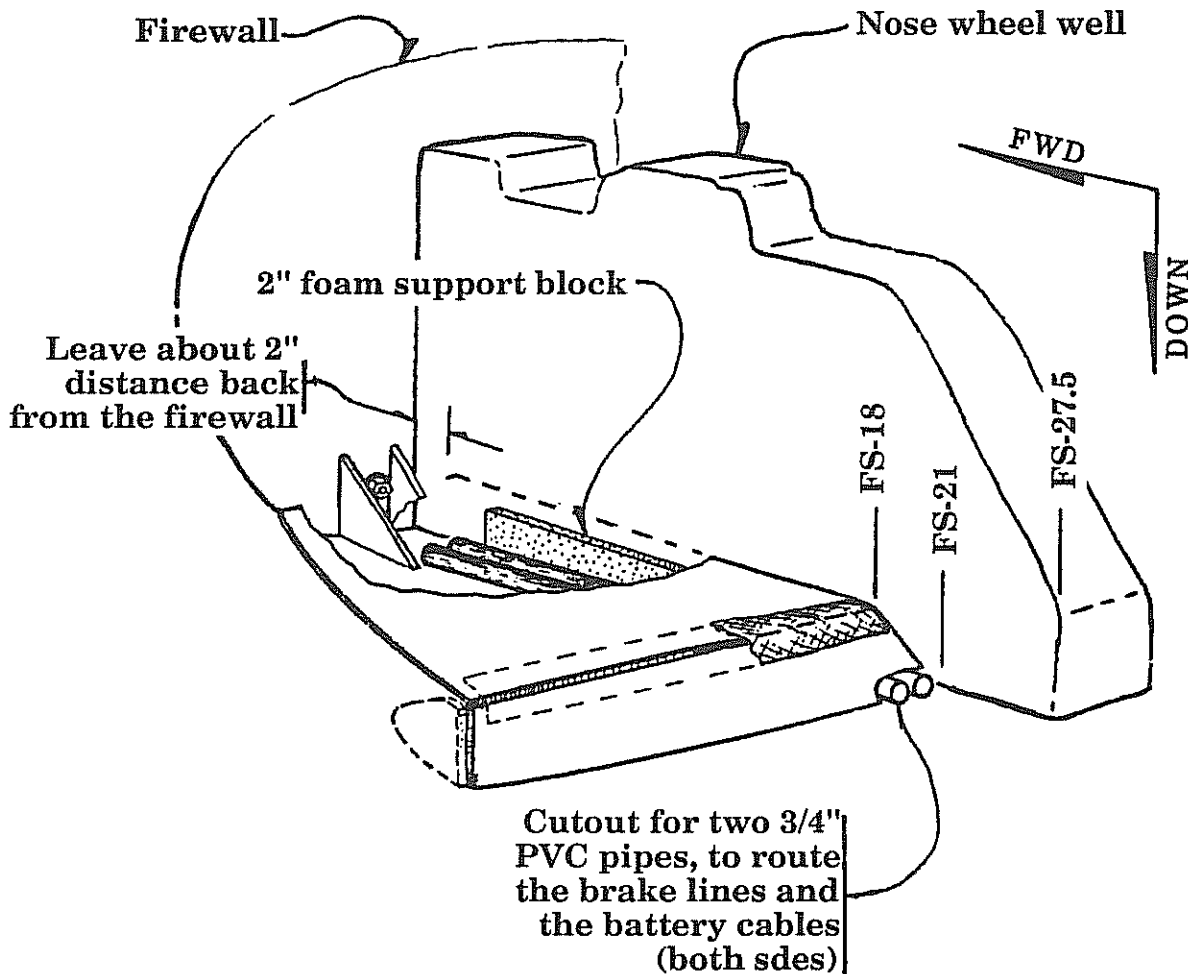

1. Select the "Cockpit Sub-Floor" template from blueprint "D". Make a cardboard pattern from this blueprint and check the fit. The floor should be flat and level relative to the longerons from left to right. The sub-floor will generally contact the tunnel sides about 2" up from the fslg bottom as measured along the vertical sides of the nose gear tunnel.

NOTE: This sub-floor can be positioned slightly higher or lower depending on your preferences. Positioning it higher will result in less "toe" room since the distance between floor and the bottom of the header tank would be reduced. Positioning it lower will increase "toe" room but also have the effect of making the floor narrower since it will contact the outboard side of the fslg at a point that is closer to center line due to the curvature of the fslg itself. Adequate room must always be maintained for access to the lower engine mount bolts and nuts. And the minimum width of the sub-floor is determined by the rudder pedal assembly since it must span across this sub-floor. See figure 12-9.

2. With the cardboard pattern fit, transfer that pattern onto the 1/4" foam core material and apply 1 BID per side. Use a grinder to sand a bevel along the outboard sides of the pattern to nest against the fslg. Place a 1/4" or 1/2" foam strip vertically against the side of the nose gear tunnel such that the inboard side of the floor can rest on it. This block can be held permanently in position with micro once it is sized properly. See figure 12-6.
3. Use a level to check that the sub-floor is in fact level, adjust the vertical foam strip as necessary to achieve a level condition.
4. Make a cut in the top skin of the sub-floor and through the core at about FS 18 so that the panel can be bent down to meet the fslg floor at about FS 21. Fit and position the panel. Place a couple of weights to hold it securely. Place a weight at the aft base to hold the angled panel down against the fslg floor as well. Add a little micro into the resultant wedge where the cut was made and apply 1 BID over it. Allow to cure in position, see figure 12-6.
5. Be sure that room is maintained at the fwd firewall end so that the engine mount attach bolts can be accessed. Also battery cables and hydraulic lines will be run through this fwd area down and under the sub-floor. See figure 12-6.

NOTE: It is not critical that the outboard, aft end of the panel wrap around and attach to the fslg and wing fillet area. This can however be done to create a neat looking installation but it is not required for strength. See figure 12-6.



6. Per figure 12-6, insert a piece of tubing such that the brake lines can be routed under the sub-floor. Also, one battery cable (#4 wire) will be routed under the floor on each side of the tunnel. Thus two tubes (or one larger tube) are needed on the pilot side and one tube on the passenger side. Standard PVC tubing or equivalent from your hardware store works well, use two 3/4" dia. tubes. The tubing should be installed such that the lines can be inserted from the aft end and there is sufficient room remaining at the fwd (firewall) end to allow the inserted lines to turn 90° upward and exit the sub-floor area without placing any undue stress or strain on them. The tubes should be run along the side of the tunnel. See figure 12-6.

WARNING: Be careful to assure that there are no sharp edges along the ends of the inserted pieces of guide tubing that could chafe the brake lines, thus sand a smooth radius to the PVC tubing ends. A little bit of micro will be sufficient to secure the tubes in position (sound proofing and the sub-floor itself will also lock the tubes in place). Allow the tubes to stick out of the aft end by about 1/4" or so.

Sub-floor hard points
Figure 12-7

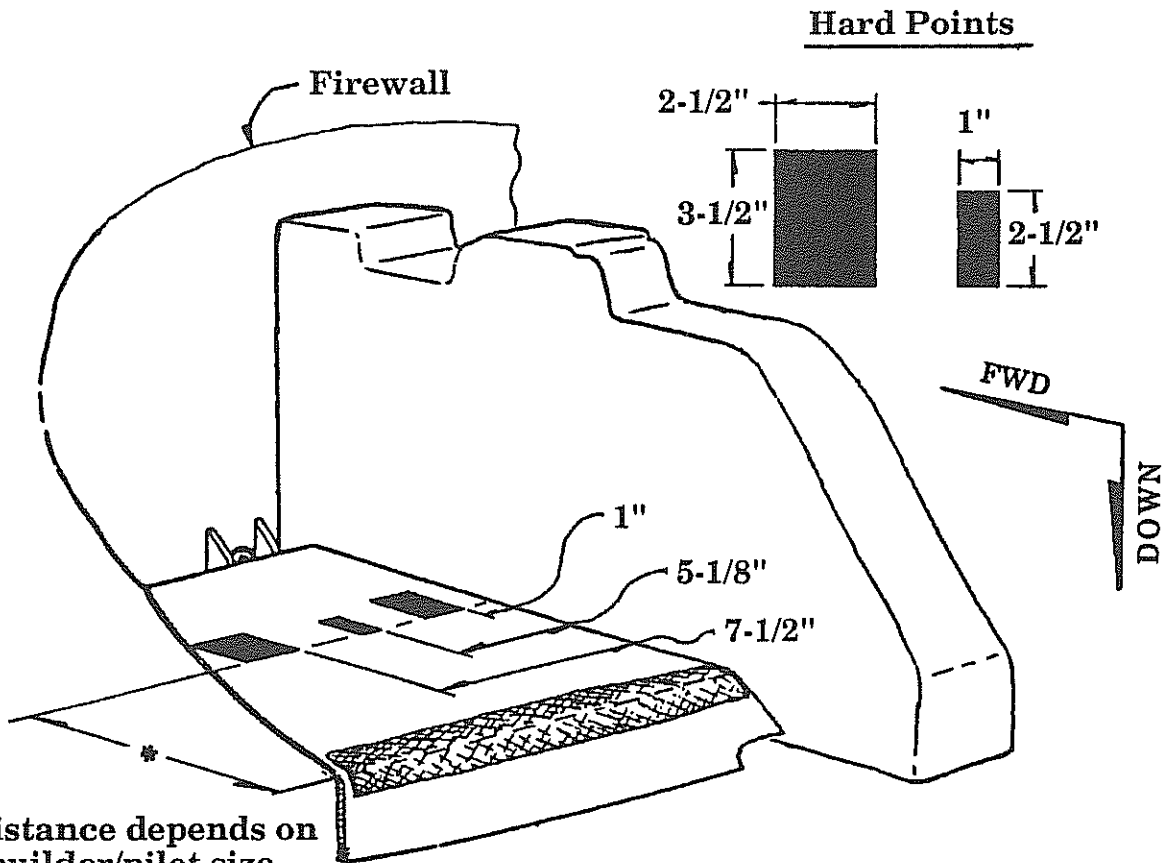

*This distance depends on the builder/pilot size

NOTE: For adjustable rudder pedals the hard points will be located / installed differently, refer to section "E", beginning on page 12-22.

7. Next, hard points will have to be installed into the sub-floor to anchor the rudder pedal assembly. For a standard, non-adjustable rudder pedal assembly, three hard points are needed, one center point and two edge points that will also anchor the brake master cylinder brackets. See figure 12-7 for locations.

NOTE: The fwd/aft location for the rudder pedal assembly will depend on your desired location for the rudder bars. If in doubt, simply make the hard point blocks longer and wait until the cockpit installations are to a point where you can sit in the seat and establish your desired rudder pedal locations then drill and attach the rudder bar mounting nut plates to the underside of the sub-floor hard points.

8. With the rudder pedal assemblies in position, check the alignment with the cable guide tubes. Adjust vertically if necessary and add the last 1 BID to secure the left guide tube to the fslg side and the right guide tube to the nose gear tunnel side wall.
9. The sub-floor will require stiffening with additional BID plies. This is to accept the loads applied by brake pedal action. See figure 12-8.
10. The rudder pedal assembly is a simple tubular unit which rotates in three synthetic pivot blocks, see figures 12-9, 12-10 and 12-11. These blocks are normally attached directly to the fwd sub-floor. This provides for a fixed rudder pedal installation. If you require a ground ADJUSTABLE RUDDER PEDAL SYSTEM, then the pivot blocks will need to be installed onto a moving "base" which slides on the sub-floor, see section "E" , ADJUSTABLE RUDDER PEDALS.



Sub-floor reinforcement

Figure 12-8

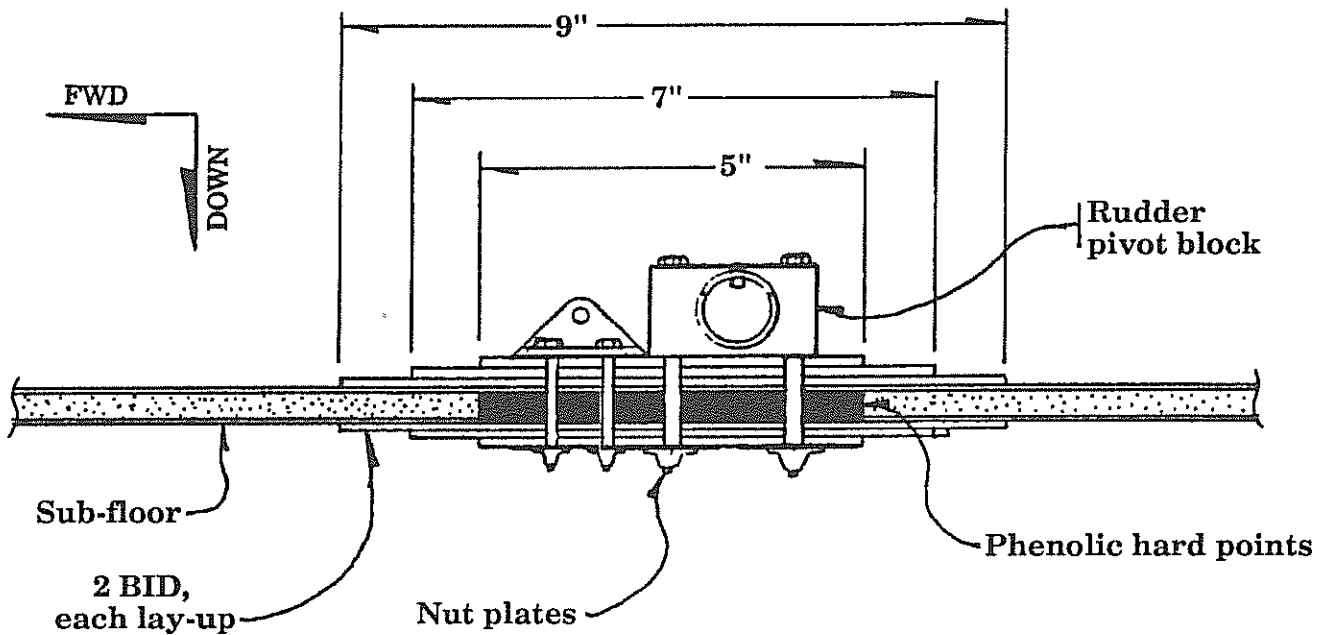

Rudder pedal assembly - installation

(Overview)

Figure 12-9

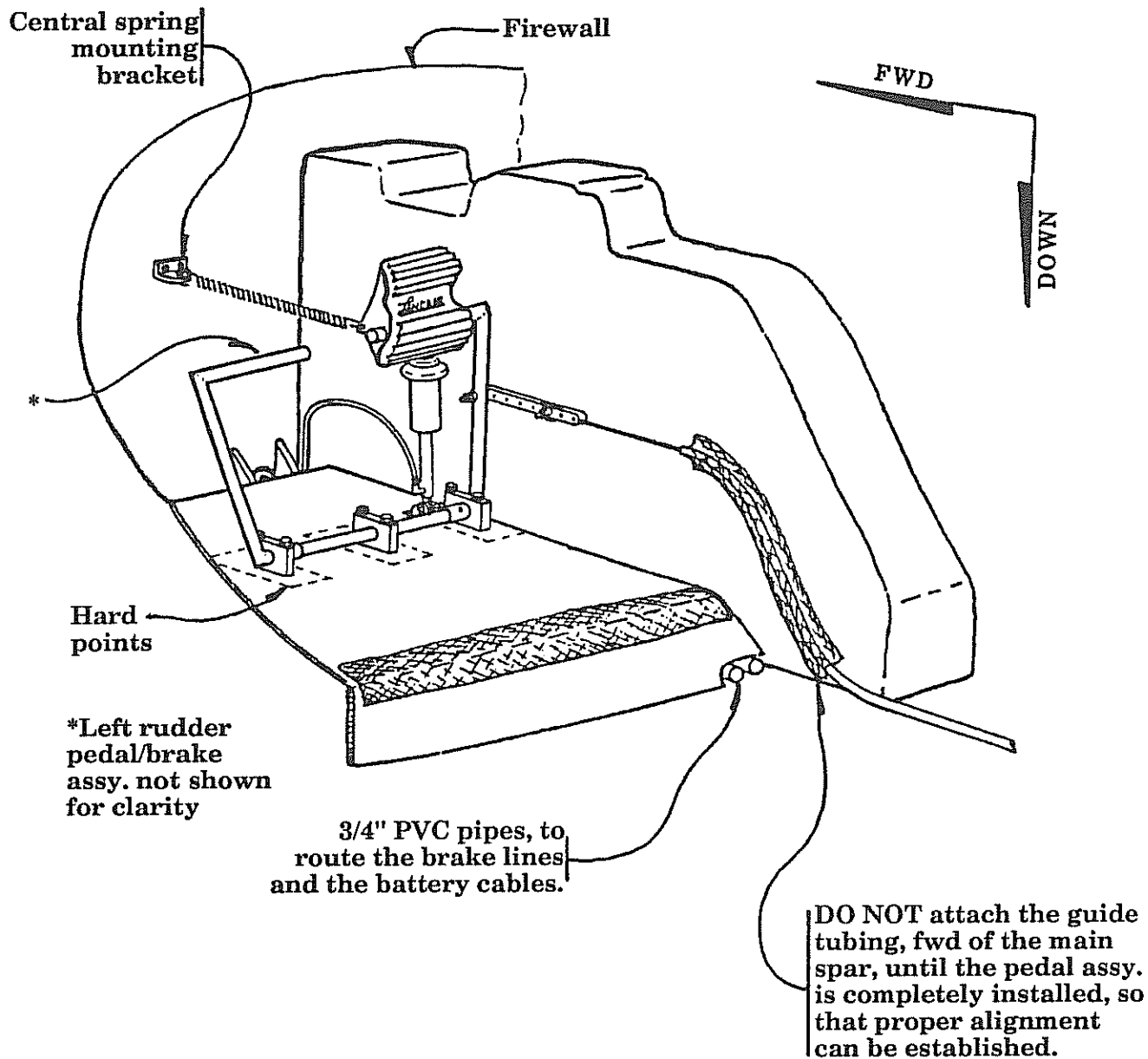

D. Brake cylinder and bottom mount bracket - installation, FIXED POSITION

Braking is accomplished via the cast rudder pedals which rotate on the rudder bars through nylon bushings, applying pressure to the master cylinders.

1. First, attach the *bottom mount bracket* to the bottom of the brake cylinder. Then attach the top of the brake cylinder to the back of the rudder pedal web. Both webs will have to be drilled (#12 bit) on each pedal, one hole is for the brake cylinder and the other is for the spring. Be sure to mount the brake cylinder to the inboard web (closest to the wheel well) on each pedal, even for the passenger side.

NOTE: At this point, the bottom mount bracket is not attached to the sub-floor. The bottom of the brake cylinder can be moved fore/aft and left/right to set the cylinder in proper vertical alignment.

2. Set the fore to aft alignment of the brake cylinder / bottom bracket just forward of the pivot bar (as close as possible, without touching the bar). Be sure that the left to right alignment of the brake cylinder is perfectly vertical. Mark the holes, move the bracket out of the way, and drill with #12 bit. The mounting holes must go through the hard points, or new hard points must be added.
3. Mount the bracket for the brake to the sub-floor per figure 12-8 and 12-9.
4. With the sub-floor hard points installed, and the additional BID plies added, the sub-floor can be permanently bonded into position. Use micro to pot it down and add 1 BID all around to attach it.

NOTE: It is highly recommended that a sound proofing material be packed solidly into the cavity between the fslg floor and the sub-floor. This material can range from a spun fiberglass material to a foam based sound proofing material. All such materials should be fire resistant and not give off toxic fumes. One source for aircraft grade sound proofing is:

E.A.R.

Division of Cabot Corp.

7911 Zionsville Rd.

Indianapolis, IN 46268

(317) 872-1111

Use C-3002-25 & C-3002-50PSA

NOTE: If you are ordering this material, you might as well order enough to finish out the whole cockpit. E.A.R. has worked with Neico to assist in development of a set of materials for Lancair insulation. Upon contacting them, assistance can be provided. In general, the required materials are:

3 sheets C3002-25 ALPSA

1 sheet C3002-50 PSA

1 sheet SD-40 ALPSA



RUDDER PEDAL PART LIST:

Qty	#	Description
2	1	Rudder pedal casting
4	2	Bushing, nylon
2	3	Position retainer (pedal) 7/8" x .058 Al. tube
1	4	Outbd rudder bar (angled)
1	5	Inbd rudder bar (squared)
3	6	Pivot block, nylon, rudder bar
2	7	Position retainer (rudder bar) 7/8" x .058 Al. tube
4	8	Adjusters - cable attach system
2	9	Brake cylinder
2	10	Attach bracket - brake cyl/base (Al. angle)

HARDWARE LIST:

Qty	#	Description
2	1	AN3-6 bolt
6	2	AN3-6A bolt
6	3	AN3-7 bolt
2	4	AN3-13 bolt
6	5	AN3-15A bolt
4	6	AN111 thimble
8	7	AN310-3 nut
10	8	K1000-3 nut plate
6	9	AN960-10 washer
8	10	Cotter pin
4	11	Pop rivet
4	12	Poly-Flow elbow, 269P
50	13	Nyla-Flow tubing, 3/16"



12-20

Chapter 12

REV. 0 / 11-1-91

RUDDER CONTROLS

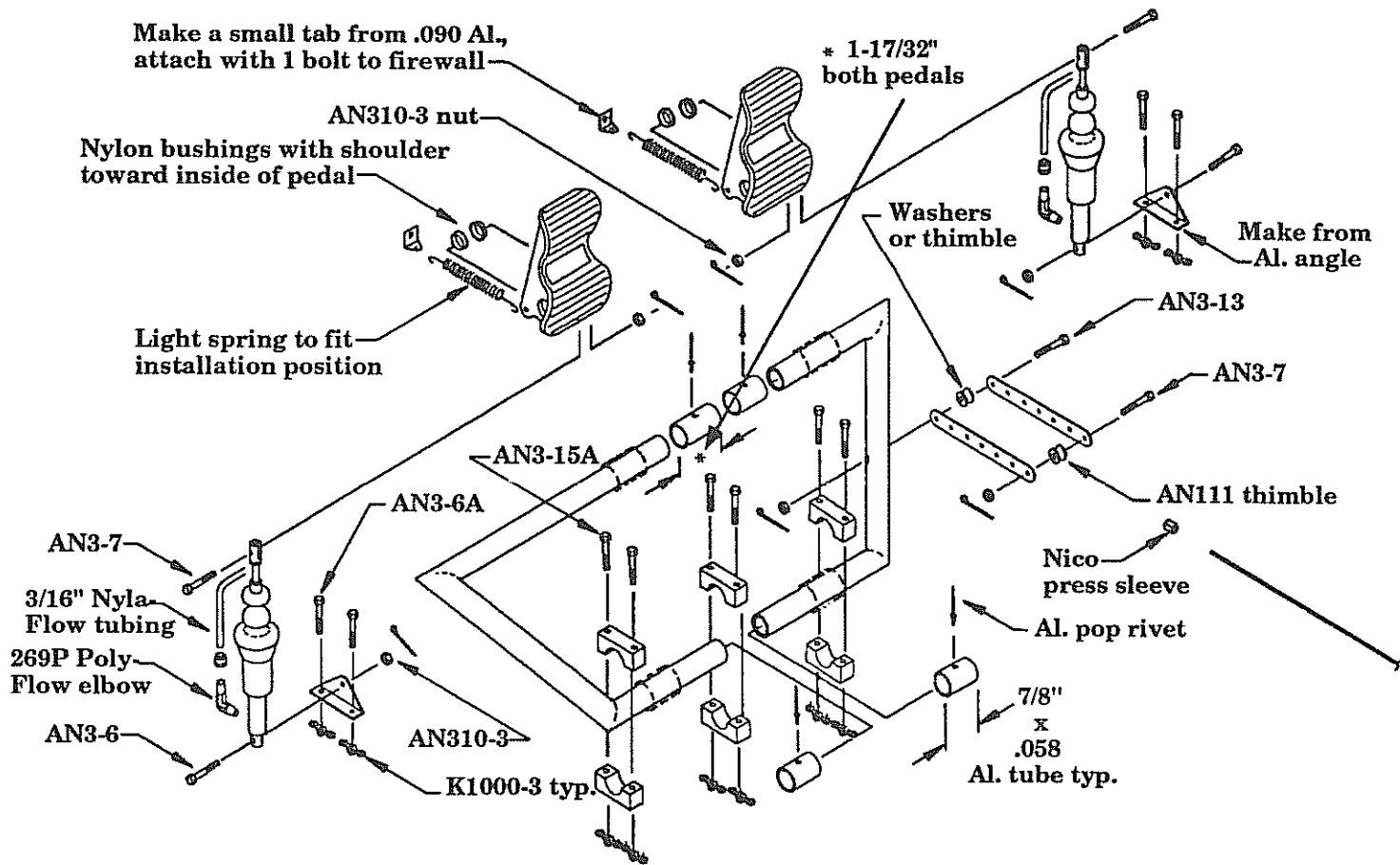

Rudder pedal assembly
(Exploded view)
Figure 12-10



RUDDER PEDAL SYSTEM ASSEMBLED VIEWS

FIGURE 12-11

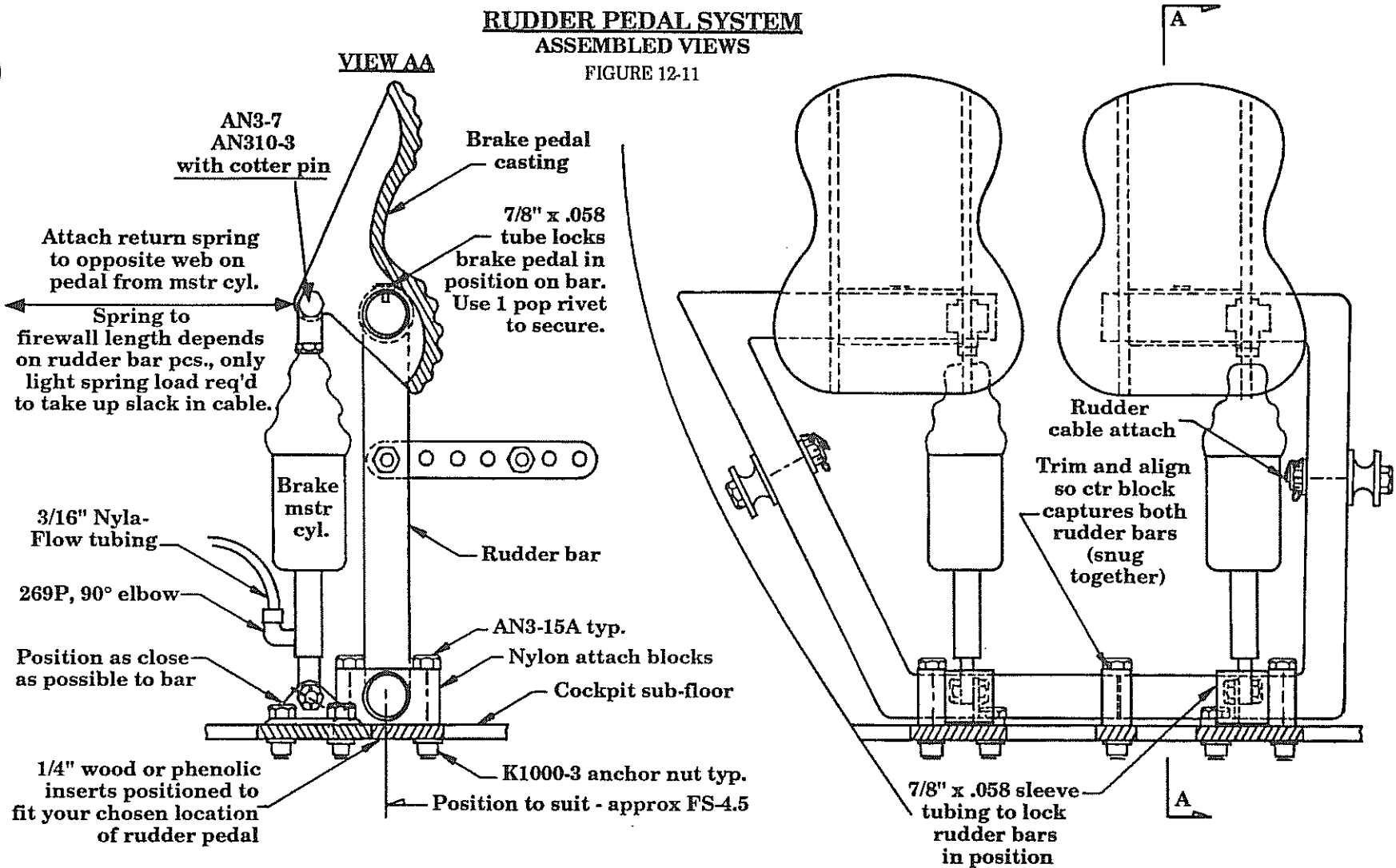

- E. **Adjustable rudder pedals, plywood slide plate system (optional)**
 If you are intending to install adjustable rudder pedals, their installation changes the procedure as follows: A slide plate must be made and the sub-floor hard points will be located differently to accommodate the slide plate. The sub-floor will be installed late in the procedure. The pivot blocks are mounted differently and the cable adjusters are made longer.

Plywood slide plate

Figure 12-12

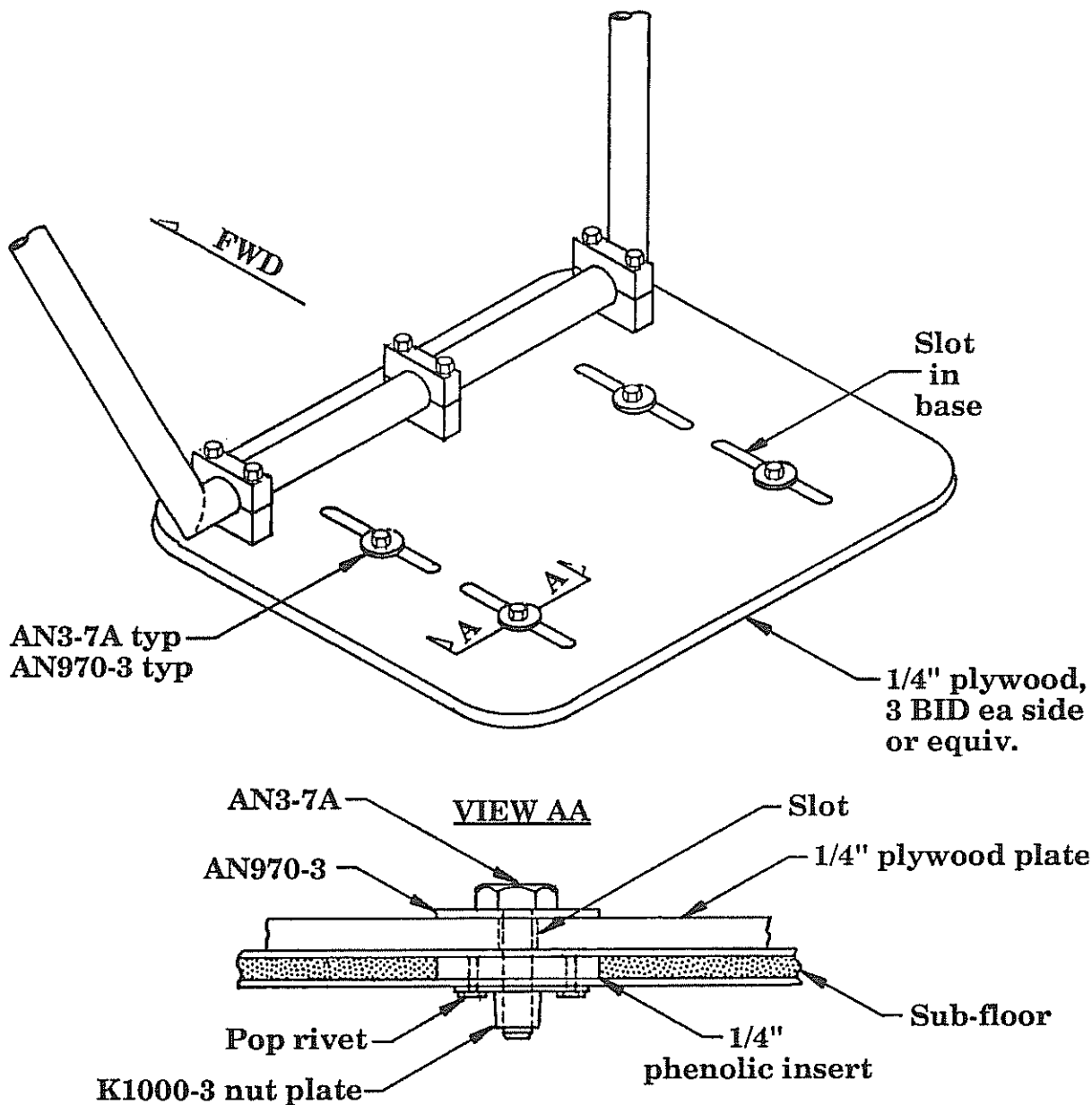

1. Make the "Adjustable Rudder Pedal Base" (base) from 1/4" plywood per figure 12-13.
2. Apply a lay up of 3 BID per side.

NOTE: The hardware on the underside of the assembled base must be flush.

3. Assemble and install the rudder pedal assembly to the base per figure 12-10 and 12-11 with the exception that the nylon Pivot Blocks must be mounted with counter sunk machine screws (MS24694-S70) from the under side of the wood base. And secure with AN356-1032 lock nuts. Also the rudder cable attachment adjusters must be made per figure 12-15, with the exception that the length must be *the length of your slots + 3"* (approximately). Braking is accomplished via the cast rudder pedals which rotate on the rudder bars through nylon bushings, applying pressure to the master cylinders.



Plywood base plate
 (Adjustable rudder pedal system)
 Figure 12-13

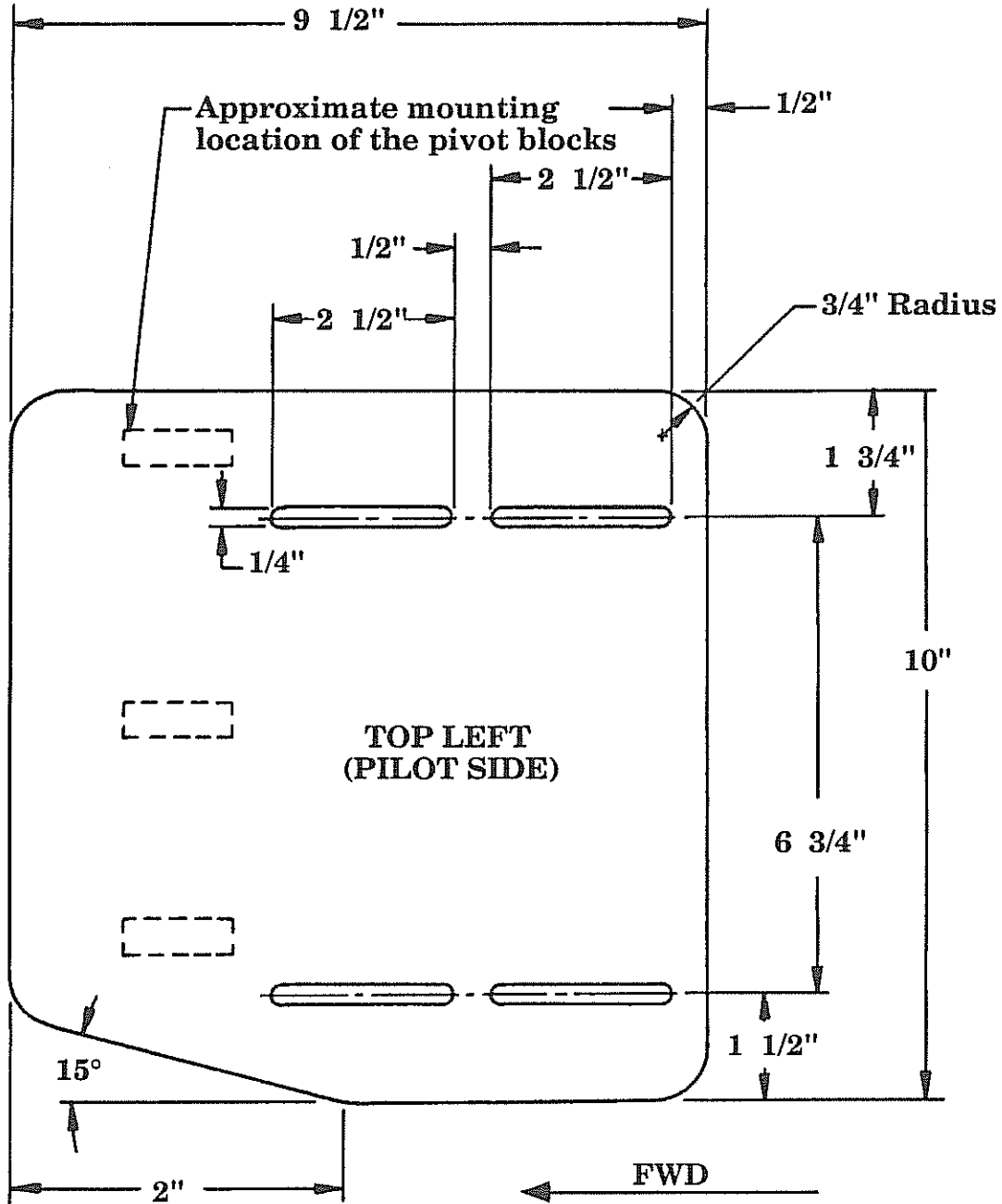

F. Brake cylinder and bottom mount bracket installation - adjustable

1. First, attach the *bottom mount bracket* to the bottom of the brake cylinder. Then attach the top of the brake cylinder to the back of the rudder pedal.

NOTE: At this point, the bottom mount bracket is not attached to the base. The bottom of the brake cylinder can be moved fore / aft and left / right to set the cylinder in proper vertical alignment.

2. Set the fore to aft alignment of the brake cylinder / bottom bracket just forward of the pivot bar (as close as possible, without touching the bar). Be sure that the left to right alignment of the brake cylinder is perfectly vertical. Mark the holes, move the bracket out of the way, and drill with #12 bit.
3. Mount the bracket for the brake to the sub-floor per figures 12-8 and 12-9. For adjustable pedals, use MS24694-S54 screws from underneath, and AN365-1032 lock nuts on top.



G. Sub-floor hard points - adjustable rudder pedal system

1. With the pedal/base assembly complete, sit in the seat to establish the desired adjustment range. Slide the pedal assembly to the aft most position. Remember that the length of the slots in your base will set the limit of the fore to aft travel.
2. Mark a reference line on the sub-floor at the aft edge of the pedal base assembly. Align the slots in the base, parallel to the nose gear tunnel. Carefully mark the outline of the base on the sub-floor.
3. Hold the base firmly. Use a 3/16" dia, bit. Drill into the sub-floor, through the fwd-most end, of each *aft slot*,
4. Put the AN3-7A bolts in the holes from the top, for alignment. Then push the base aft against the bolts. Drill holes in the sub-floor, at the fwd end of the *fwd slots*, in the same manner as above.
5. Remove the pedal assembly and the sub-floor from the fslg. Cut 1-1/2" squares through the bottom skin of the sub-floor, centered on the bolt holes. Remove the foam core material. Flox in 4, (1" x 1") phenolic hard points (1/4" thick) and cover with a (4" x 4") 2 BID lay-up on the sub-floor from the underside.
6. From the top side of the sub-floor, re-drill the bolt holes through the hard points. Then install the nut plates (K1000-3) from the bottom with countersunk steel pop rivets (not supplied).
7. Now the sub-floor can be installed per step 1, section D, page 12-19.
8. Install the pedal assy to the sub-floor, per figure 12-12.

**This is the end of the section dedicated to just the
ADJUSTABLE RUDDER PEDAL SYSTEM.**



H. CONTROL CABLE INSTALLATION (FIXED AND ADJUSTABLE)

1. Select the stainless steel rudder cable. One end must have a single clevis type receptacle on it and it must be bent down to approximately 25°. This can be easily accomplished by placing the "tab" end of the receptacle in a vise and carefully bending the shank downward until a 25° angle from straight is achieved.

CAUTION: Be careful when bending to not create any sharp creases from the bend. These could develop into stress concentration points and cause premature failure. A 1/8" radius should be the minimum bend radius. The purpose of this bend is to achieve a straight pull from the bare cable to the receptacle shank. This will thus not cause cable wear and the smoothly bent steel "tab" can easily take the required loads at the control horn. Insert the rudder cable itself from the aft end and push it fwd through the guide tubing.

WARNING: Do not use cable with thimble type terminations at this rudder attach position. A swaged end must be used.

NOTE: It is extremely difficult, if not impossible, to achieve a nice cut on the stainless steel cable using a set of shears or dikes. A simple means of trimming this stainless steel cable is to use a good sized cold chisel (example: 3/4" dia. chisel about 5" long) and give the cable *only* one brisk (hard) smack with a hammer. The cable should be laid on a steel or aluminum plate for this hammer strike. This will produce a clean cut every time. Protect your eyes during this procedure since the cable end can sometimes fly up as a reaction to the impact.

2. Slip an AN3-7 bolt through the cable end clevis thus attaching at the aft end to the rudder control horn. Use an AN310-3 castle nut and cotter pin. There's no point in setting the cotter pin yet since you'll be taking the rudder off again for painting etc. See figure 12-14.



Rudder cable to control horn attachment
(aft end)
Figure 12-14

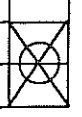
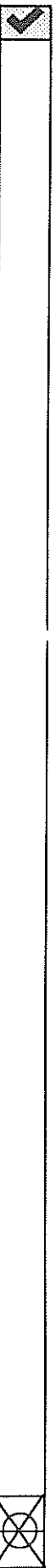
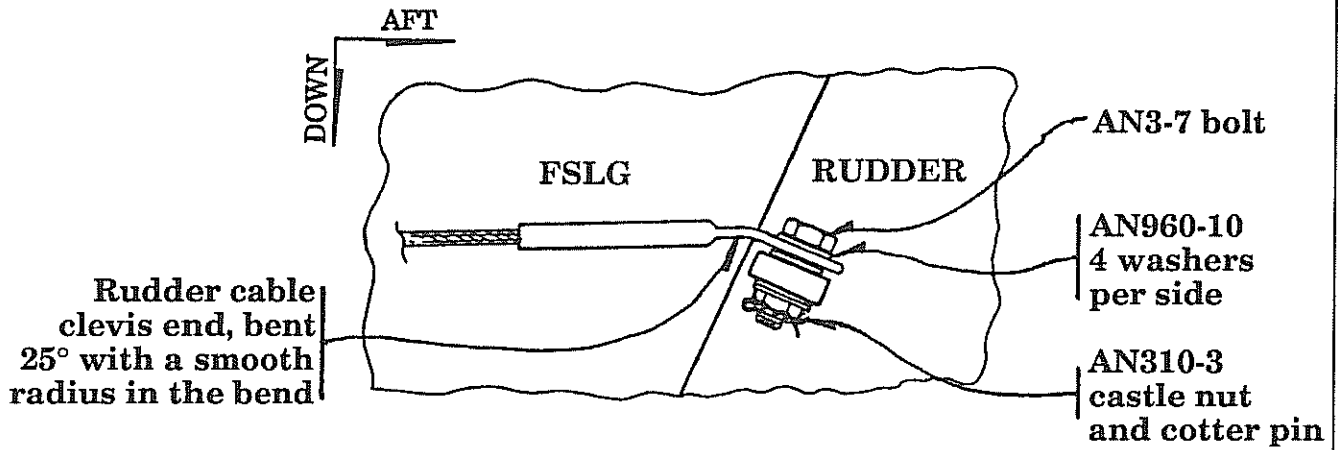

**I. Final rudder pedal to cable attachment & adjustment
(fixed & adjustable)**

1. Align the Nyla-Flow tubing (along the fslg side and the nose wheel well) for a, parallel to the floor, straight line pull with the #12 drill hole in the vertical bar on the pedal assembly.
2. Trim the guide tubing to allow 5" of exposed cable to the adjuster with the pedal in its aft-most position.
3. Secure the guide tubing in position with 1 BID, see figure 12-9.
4. Clamp the rudder in neutral, centered position.



J. Rudder bar travel & neutral position (fixed & adjustable)

1. Establish the rudder pedals travel and "neutral position" as follows: Travel should be 1-3/8" fwd & 1-3/8" aft of "neutral position". This is measured at the #12 drill hole in the vertical member of the bars. Note where the brake cylinder begins to compress during the forward travel of the rudder bar, and be sure that the fwd extreme stops short of brake cylinder compression.

NOTE: We have found "neutral" to be approximately 15° aft of vertical for most installations. The rudder pedals should be adjusted such that with normal foot movements, no braking action is applied to the pedal assembly (i.e., the brake master cylinder is not depressed during normal rudder pedal action). It should take a concerted effort to apply brake action with the toes.

FOR THE ADJUSTABLE RUDDER PEDAL SYSTEM, set the base in the middle of it's fore/aft travel, as well.

2. At the fwd end of the rudder bars, the cable attachment will be per figure 12-15. This will require that you make four "Adjuster" pieces per figure 12-15.

NOTE: IF DUAL RUDDER PEDALS are to be used, then 8 adjusters will be required.

3. Bolt the adjusters to the outside of the vertical pedal bar, with the castle nut and cotter pin on the inside of the bar. Use washers between the two adjusters, as spacers, to get the same thickness as the AN111 thimble, or use an extra thimble as a spacer. Do not secure the bolt too tight, the adjusters must pivot with the pedal movement.

4. Slide the Nico Press Sleeve onto the exposed rudder cable.

NOTE: The following steps will be much easier with a helper, two hands are not enough.

Only one adjuster is used to position the thimble on the cable, otherwise the other adjuster would prevent finger access to the cable / thimble / press sleeve.

5. Temporarily insert a bolt through the AN111 thimble. Push one of the pair of adjusters out of the way, insert the bolt into a hole in the middle of the other adjuster.
6. Wrap the cable around the thimble and thread it back through the Nico Press Sleeve. Now, pulling on the end of the cable, work all of the slack out, until the cable is tight. Slide the Nico Press Sleeve up tight against the AN111 thimble and hold the press sleeve in position with finger pressure.



7. Remove the bolt from the thimble and adjuster. Crimp the Nico Press Sleeve **SECURELY**, in the middle and on each end of the Nico Press Sleeve so that it is evenly crimped.

NOTE: There are many brands of crimpers available in a wide price range. Even the lower priced tools work well, **BUT BE SURE TO FOLLOW THE MANUFACTURERS DIRECTIONS!!**

WARNING: Nico Press Sleeves **MUST** be crimped with proper crimpers. Pliers are **NOT** sufficient.

NOTE: When setting the cable lengths, the angle of the pedal / bar assembly will effect the cable length. It is best to sit in the seat, with padding to simulate the upholstery thickness, and have someone assist in marking positions. Allow 1-3/8", measured at the cable attach point on the rudder bars, fwd and aft of neutral for rudder bar travel, for a total, fore to aft travel of 2-3/4".

8. Trim off any excess cable.
9. Bolt the crimped thimble / cable end between the adjusters at mid point.
10. Repeat the process for the other pedal.

NOTE: Light springs should be added to the assembly from the back of the pedal to the firewall. This is merely to keep the pedals up and a slight tension on the cable lines. These springs are left to builder purchase since they are generally attached to the firewall and the needed length will vary with each builder's height. Attach the springs to the firewall with a small piece of angle aluminum. One piece can be made to accommodate both pedals by locating it mid-span on the firewall between the two points where the springs attach to the pedals. See figure 12-16. Simple tension springs from the local hardware store will work nicely. A diameter of approximately 3/8" is generally good. The length will vary depending on your location for the pedal assembly

FOR THE ADJUSTABLE RUDDER PEDAL SYSTEM, a long spring will usually tolerate most travel ranges. The springs will merely tighten up when the pedals are pulled aft.

11. Attach one end of each spring to the back of each pedal (in the web not used by the brake cylinder), and attach the other end to one common bracket on the firewall (mounted midway between the two pedals). See figure 12-9.



Rudder cable to pedal bar attach system

(fixed and adjustable)

FWD END

Figure 12-15

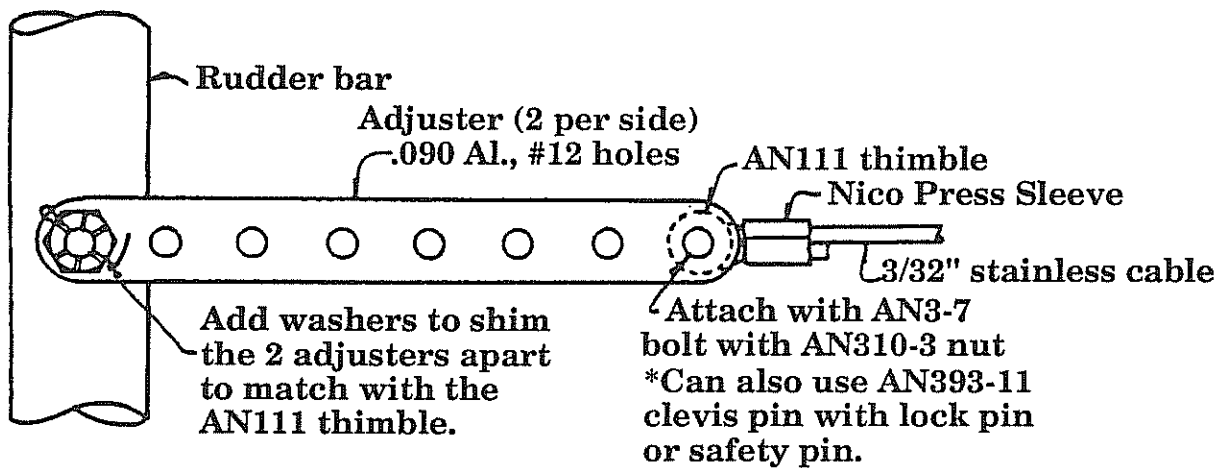

12. When the final installation for the rudder and cables is performed, snug the aft clevis end on the rudder bellcrank. Do not over-tighten since this piece must swivel slightly on the rudder control horn. Use a cotter pin to secure the castle nut in place. The bolt should insert from the top with the castle nut on the bottom, with the cotter pin inserted from the fwd side and facing aft. See figure 12-14.

Brake / spring attach bracket

Brake: 2 required

Spring: 1 required

Figure 12-16

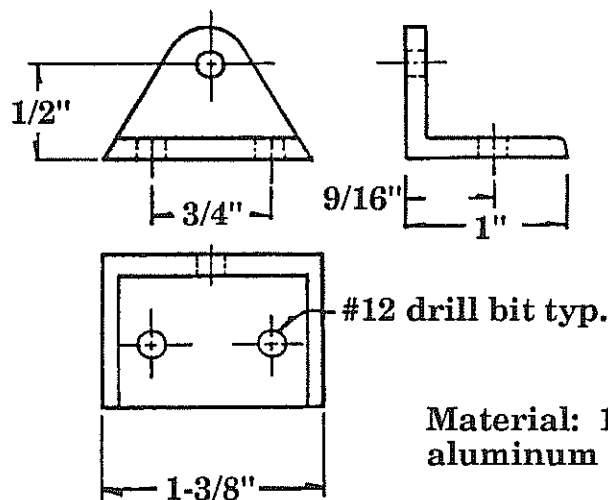

K. Dual rudder controls - optional

Controls can also be installed onto the right side for passenger rudder control. This installation will weigh about 7 lbs. It is simply unnecessary for rudder control during virtually all standard flight conditions. Rudder is of course needed for cross wind landings and brakes are needed for taxi steering. The passenger side pedal assembly is a mirror image of the pilot's (refer to step 11, page 12-17 for assembly instructions), and may also be made adjustable (see section D, page 12-18). This section will address the rudder control installation as it is effected by the addition of right side rudder controls.

Dual rudder control system

Figure 12-17

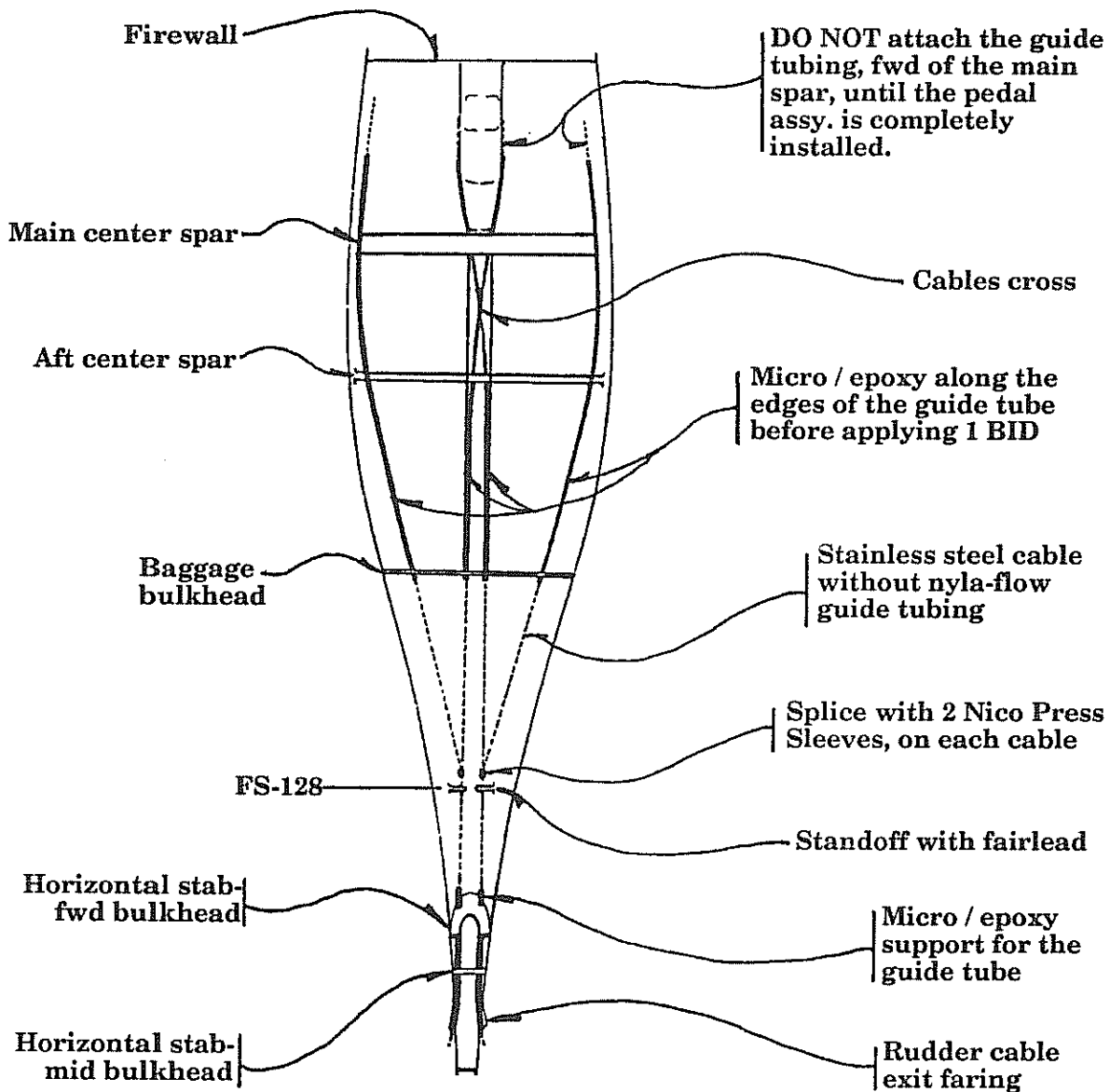

Pilot side - dual rudder controls

Figure 12-18

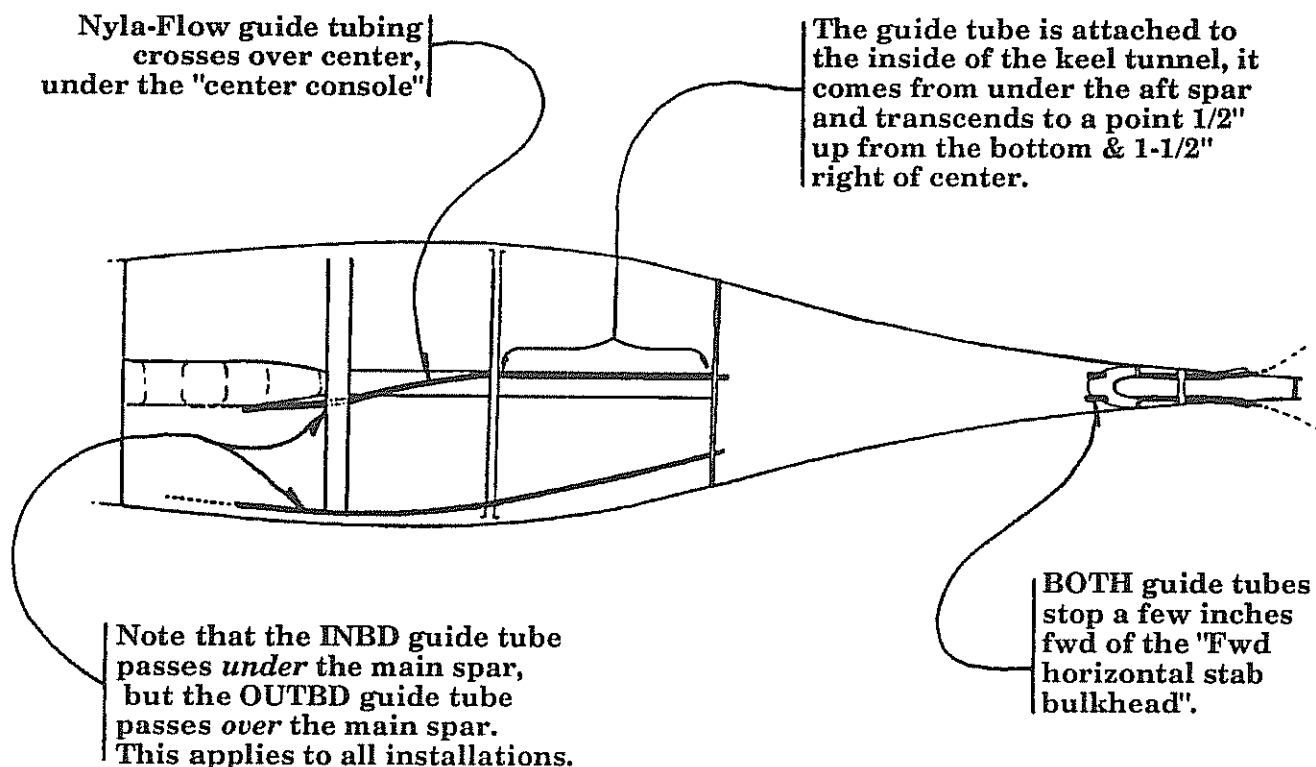

1. The pilots *right* side, control cable guide tube installation, will be identical to the standard installation. The pilots *left* side control guide tube, which runs along the fslg, will be terminated at the baggage bulkhead in a manner similar to that used for the other cable guide. See figure 12-18.
2. On the right side of the fslg, fit a "mirror image" installation of the above guide tubing installation. This guide tubing on the fslg right side will thus be an identical mirror image of what was installed onto the left side of the fslg.

The guide tubes that run down the center of the fslg will cross over each other in the cockpit area (under the console). The location of the cross is not critical.

Thus, the baggage bulkhead will have two guide tubes terminating at the central area of it. The guide tube that is on the passenger side will actually be for the pilots right rudder control. The guide tube on the pilots side will be for the passenger's left rudder control. See figure 12-17.

NOTE: From aft of the baggage bulkhead, the stainless steel control cable will not be in a guide tube until it reaches the two horizontal stab bulkheads. It will run through cable guide from the horizontal stab fwd bulkhead to the exterior of the fslg. A standoff will be required on the tail cone to hold the cables off the fslg. See figures 12-17 and 12-19.

LANCAIR® 320FB

12-35

Chapter 12

REV.

0 / 11-1-91

RUDDER CONTROLS

3. Use the full size "standoff" template (figure 12-20) to make a cardboard pattern for checking the fit and placement. Mark the hole center and make a 1/4" hole for aligning the standoff.
4. Thread the right and left cables fwd, in through the exit faring and through the 1/4" hole in the cardboard pattern (be sure to thread the pattern from the back, with the left cable in the left pattern, etc.). *From here fwd the routing of the cable is temporary and for alignment only.*
5. Route the left side cable to the guide tubing that is just to the left of center on the baggage bulkhead, and the right side cable to the guide tubing to the right of center. Pull tight and clamp the ends of the cables.
6. The pattern should be suspended on the exposed cable. Slide the pattern fore or aft and trim as necessary to establish a good fit that allows the cable as straight a path as possible without contacting the fslg. The standoff should fit at approximately FS 128.

WARNING; This temporary routing is for standoff alignment only, **THIS IS NOT THE PROPER ROUTING OF THE CONTROL CABLES.**

NOTE: The elevator controls will pass down the center of the fslg floor. The rudder cables must be a minimum of 2", each side of the fslg center line, to avoid interference.

7. When you have adjusted the standoff pattern for best fit and location, carefully mark the fslg contact area for both, the right and left side.



Standoff / fairlead installation

(Dual pedal system, left standoff shown)

Figure 12-19

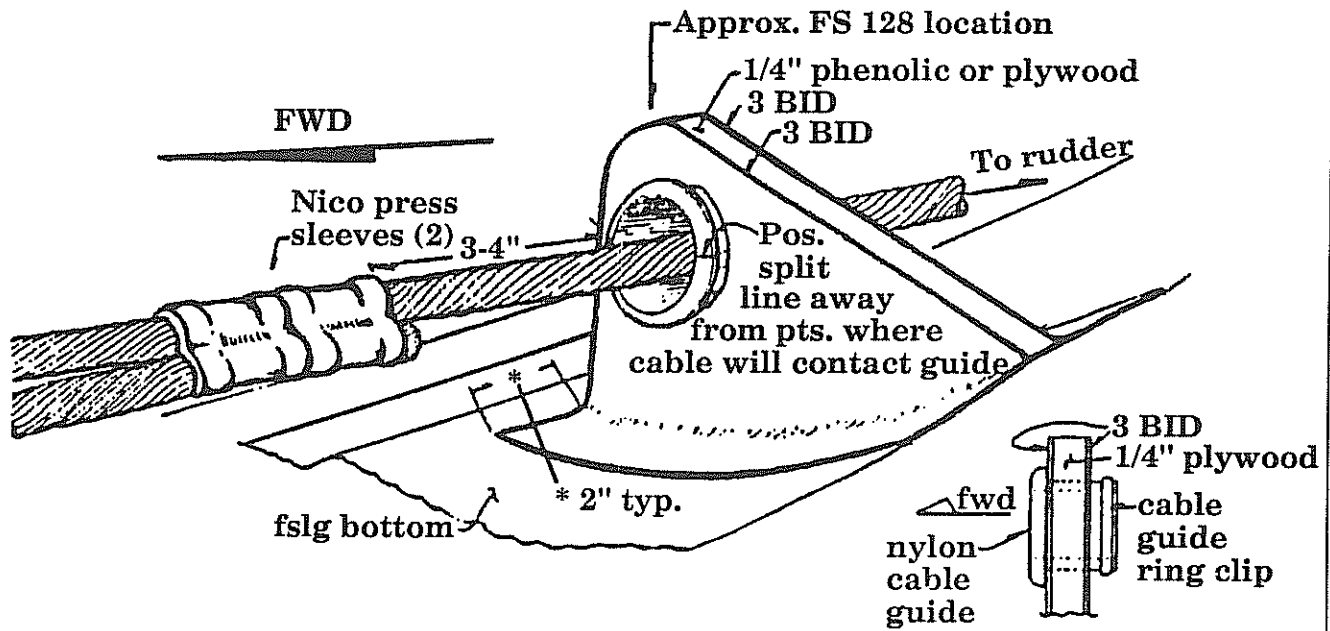

STANDOFF PATTERN

Dual pedal system

Figure 12-20

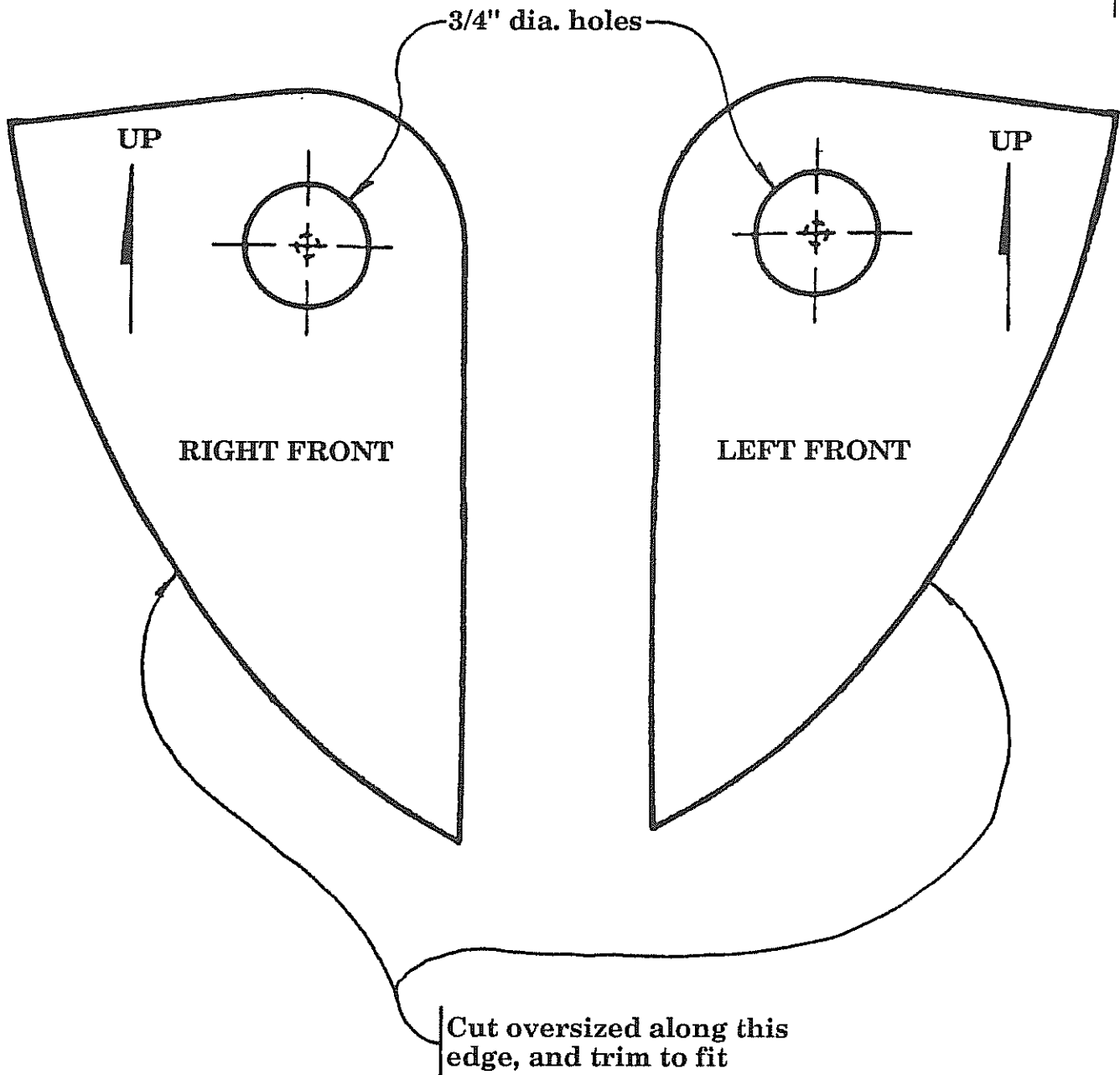

8. Remove the cables and the pattern from the fslg. Transfer your patterns to 1/4" plywood and cut out both standoffs. Be sure to mark the hole centers.
9. Drill the 3/4" holes for the fairleads. Sand the edges smooth.
10. Install them onto the fslg inner skin using epoxy/flox and 3 BID per side. This BID should run up the full fwd and aft faces of these pieces. It is probably easiest to lay the BID over the hole. During the green stage or after full cure (use a heat gun to soften), trim the BID away with a sharp utility knife or an Xacto knife.
11. Insert the fairleads into the 3/4" hole drilled into the standoff pieces. These install from the fwd side with the retaining clip on the aft side, see figure 12-19.

NOTE: The continuous cables will be routed to the pilots rudder pedals (the right cable to the right pedal, and the left cable to the left pedal). The passenger side control cables will be spliced to the pilots cables fwd of the standoff.



L. Final installation - pilots side rudder cables

1. Use the cables with the clevis ends. Thread the left rudder cable, fwd through the left exit faring, through the left standoff, through 2 NICO PRESS SLEEVES, and fwd of the baggage bulkhead through the left-most Nyla-Flow guide tube. Pull the cable tight to the firewall.
2. Now thread the right cable fwd through the right exit faring, through the right standoff, through 2 NICO PRESS SLEEVES, and fwd of the baggage bulkhead through the Nyla-Flow tube just to the right of center. Fasten the right and left clevis to the rudder control horn, per figure 12-14. Pull the cable tight to the firewall.

NOTE: Both of the cables should be on the PILOTS SIDE. This routing is used so that in the event of a splice failure, the pilot will retain rudder control.

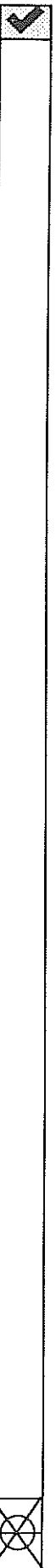



M. Routing passengers side rudder cables

1. Be sure the rudder is clamped straight so that the clevis ends are even.
2. Use cables without end fittings. Start at the left standoff. Slide the 2 Nico Press Sleeves along the pilots cables, to a point 3" - 4" fwd of the stand-off. Insert one end of the passengers left foot cable in through both Nico Press Sleeves, and crimp securely. See figure 12-19.

WARNING; Nico Press Sleeves MUST be crimped with proper crimpers. Pliers are NOT sufficient.

3. Thread the other end of the cable, fwd through the guide tube that sticks out of the baggage bulkhead, just to the left of the center. Pull up slack where the cable exits the guide tube, by the passengers left foot.
4. Repeat the process for the right cable.
5. Refer to the previous sections for instructions to finish the installation.



12-41

Chapter 12

REV. 0 / 11-1-91

RUDDER CONTROLS

CHAPTER 13:

GEAR & GEAR DOOR ADJUSTMENTS

REVISIONS

From time to time, revisions to this assembly manual may be deemed necessary. When such revisions are made, you should immediately replace all outdated pages with the revised pages. Discard the out dated pages. Note that on the lower right corner of each page is a "revision date". Initial printings will have the number "0" printed and the printing date. All subsequent revisions will have the revision number followed by the date of that revision. When such revisions are made, a "table of revisions" page will also be issued. This page (or pages) should be inserted in front of the opening page (this page) of each affected chapter. A new "table of revisions" page will accompany any revision made to a chapter.

Arrows

Most drawings will have arrows to show which direction the parts are facing, unless the drawing itself makes that very obvious. "A/C UP" refers to the direction that would be up if the part were installed in a plane sitting in the upright position. In most cases the part shown will be oriented in the same position as the part itself will be placed during that particular assembly step. However, time goes on and changes are made, so careful attention should be paid to the orientation arrows. That old cartoon of the guy agonizing over the plans for his canoe, built one end up, one end down, should not happen in real life. Especially to you.

CONTENTS

1. INTRODUCTION
2. DRAWING LIST
3. SPECIAL PARTS, TOOLS & SUPPLIES LIST
 - A. PARTS
 - B. TOOLS
 - C. MATERIALS & SUPPLIES
4. PROCEDURE
 - A. FINAL ASSEMBLY
 - B. NOSE GEAR DOOR
 - C. MAIN GEAR DOORS
 - D. MECHANICAL INBD DOOR SYSTEM
 - E. HYDRAULIC INBD DOOR SYSTEM (OPTIONAL)

1. INTRODUCTION

Refer back to chapter 5, section "D", "Main gear door cutouts", page 5-14. This previous section discussed cutting out the main gear doors and attaching them. Also Chapter 6, sections B & C, starting on page 6-14, discussed the main gear middle door and the nose gear door. This section will address the control systems and adjustments of these gear doors.



13-2

Chapter 13	REV. 0 / 11-1-91	
GEAR & GEAR DOOR ADJUSTMENTS		

2. DRAWING LIST

Drawing	Page	Title
13-1	13-8	Hydraulic cylinder stop assembly (gear actuator)
13-2	13-10	Nose gear door retract assembly (overview)
13-3	13-11	Positioning the nose gear door retract cylinder
13-4	13-14	Attachment plate, sequence valve
13-5	13-16	Positioning the nose gear sequence valve & micro switch
13-6	13-19	Cable exit ramp, Nyla-Flow guide tubing
13-7	13-20	Mechanical inbd gear door system
13-8	13-23	Positioning the retract cylinder
13-9	13-24	Hydraulic inbd gear door system
13-10	13-26	Positioning the main gear sequence valve
13-11	13-28	Attaching the main gear sequence valve



3. EQUIPMENT REQUIRED - SPECIAL PARTS, TOOLS & SUPPLIES

A. Parts

- Parts for this chapter will depend upon options chosen for your particular plane.



13-4

Chapter 13	REV.	0/ 11-1-91	
GEAR & GEAR DOOR ADJUSTMENTS			

B. Tools

- Ruler or tape measure
- Dremel™ type rotary grinder
- drill motor
- drill bits: 1/8"
#12
#30
- Small level or Smart-Level, or compass for measuring degrees of elevation
- Pencil
- 2) C-clamps, small
- Carpenter's square
- 1/4-28 tap



13-5

Chapter 13	REV.	0 / 11-1-91	
GEAR & GEAR DOOR ADJUSTMENTS			

C. Materials & supplies

- epoxy
- flox
- BID cloth
- micro
- 3/16" Nyla-Flow tubing
- sandpaper, assorted grit
- some 1/4" plywood
- Duct tape or release tape
- MC or acetone for cleaning
- 3/8" x .083" aluminum tubing
- Cardboard for templates
- Instant glue or hot glue
-
-
-



4. PROCEDURE

A. Final assembly

Adjusting the gear up stops

Before the landing gear doors are adjusted for proper opening and closing, the gear legs **must** be adjusted with respect to their **up limit stops**. Without up limit stops, the full amount of hydraulic pressure would be pulling against the system at all times. The systems were not designed for such a condition.

WARNING: These gear up (or retract) limit stops are critical to safe operation of the landing gear mechanisms. Failure to establish proper limit stops would result in gear failure.

1. All three landing gear retract hydraulic cylinders must create "up stops" within themselves. These "stops" can be internal or external. Internal stops would result if the cylinder piston were to bottom out within the cylinder body. This may be achievable through adjustments of the rod end bearing on the shaft. Due to acceptable builder variations, this is not always possible so we therefore supply you with "cylinder stops" which can be slid over the shaft prior to attaching the check nut and rod end bearing. This will then create an external stop by jamming between the check nut and the face of the cylinder body. See figure 13-1 for these machined aluminum cylinder stops, three are required and supplied.
2. Retract the landing gear (the procedure is the same for either the main gear or the nose gear) and determine if the piston can be made to bottom out within the cylinder when the gear is fully retracted. You will have some amount of adjustment latitude by screwing the rod end bearing either in or out on the piston shaft.

NOTE: The bearing must have been threaded onto the shaft at least 5/16". It must also have sufficient threads remaining (when threaded on to the maximum) to allow for the check nut to thread on first.
3. If adjustment can be made to create a "bottomed out" piston at full retract, then the "cylinder stop" will not be required.
4. If the above can not be achieved, then attach the cylinder stop sleeve by slipping it onto the piston shaft before the check nut and bearing are attached. The sleeve must be slid on such that its internal "shoulder" is AWAY from the cylinder body. This then allows the sleeve to slide over the shaft and the shoulder prevents it from freely sliding all the way up the shaft. The shoulder therefore functions as a "keeper" to keep the sleeve located at the threaded end of the shaft.
5. Next thread the check nut and bearing onto the shaft.



Hydraulic cylinder stop assembly

(Gear actuator)

Figure 13-1

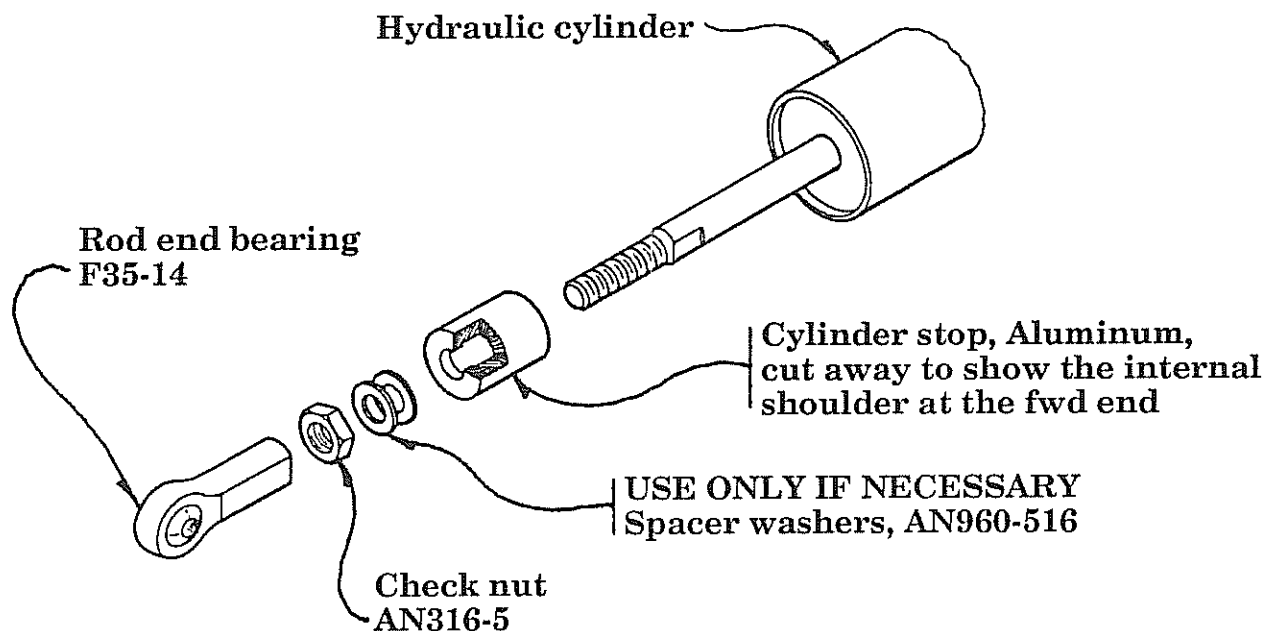

6. Retract the gear again and establish an external stop by having the sleeve jam between the check nut and the cylinder body. This can be adjusted in two ways:
 - a. The sleeve can be cut down in length if the piston shaft must retract farther into the cylinder in order to achieve full retract position. This will be a trial and fit procedure requiring several on and off installations until the proper dimension is set.
 - b. If the sleeve is not yet tight when the gear is fully retracted, then the dimension will have to be increased. This can be accomplished using 5/16" washers (AN960-516). These washers **MUST** be positioned between the check nut and the sleeve body so that they too are contained at the threaded end of the shaft.

With both of the above adjustment approaches, the bearing can be used to somewhat fine tune the adjustment by threading it more or less onto the shaft. Be sure that the proper amount of threads are engaged, though.

7. When the adjustment is correct, you will be able to (by hand only during this adjustment phase) push the gear into the full retract position and by feeling the sides of the sleeve, note that it is indeed jammed tightly between the check nut and the cylinder body. Tighten the check nut against the rod end bearing. This will complete the adjustment.

B. Nose gear door

The nose gear door is actuated by hydraulics. This system is comprised of one sequence valve and one retract cylinder. The door retract cylinder is much smaller than the actual landing gear retract cylinders and has a spring assembly over its shaft. The system is operated via hydraulic pressure from only the "gear up" side. This port is the one nearest the spring/shaft assembly. The upper port, nearest the bolt attachment, will not normally be used for the nose gear door. It will, however, be used for the two main gear doors if you purchase the main gear door hydraulic retract option.

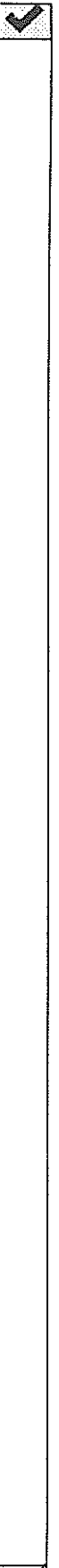

NOSE GEAR DOOR RETRACT ASSEMBLY

Overview
Figure 13-2

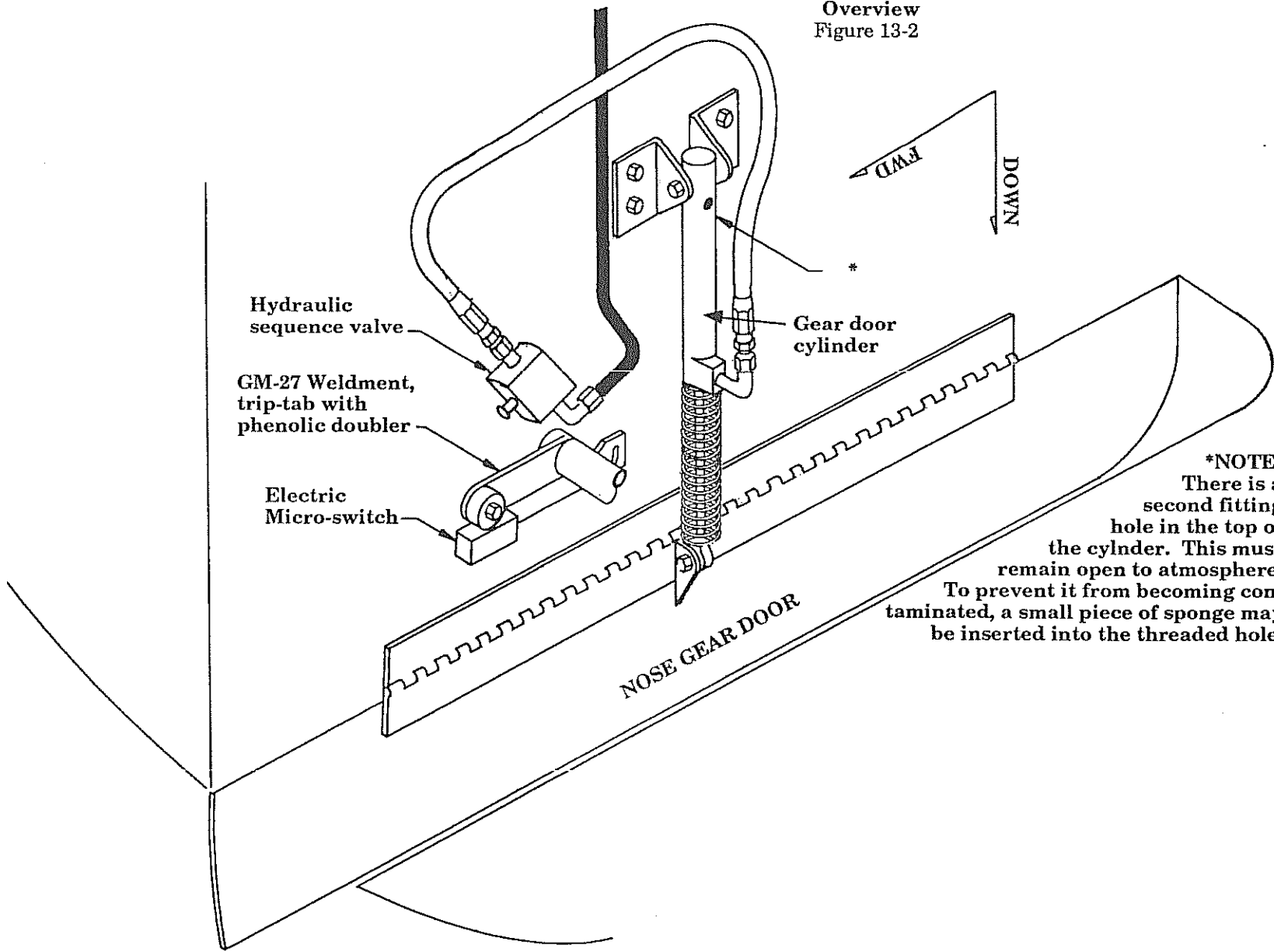

***NOTE:**
There is a second fitting hole in the top of the cylinder. This must remain open to atmosphere. To prevent it from becoming contaminated, a small piece of sponge may be inserted into the threaded hole.



Positioning the nose gear door retract cylinder

(View inside tunnel)

Figure 13-3

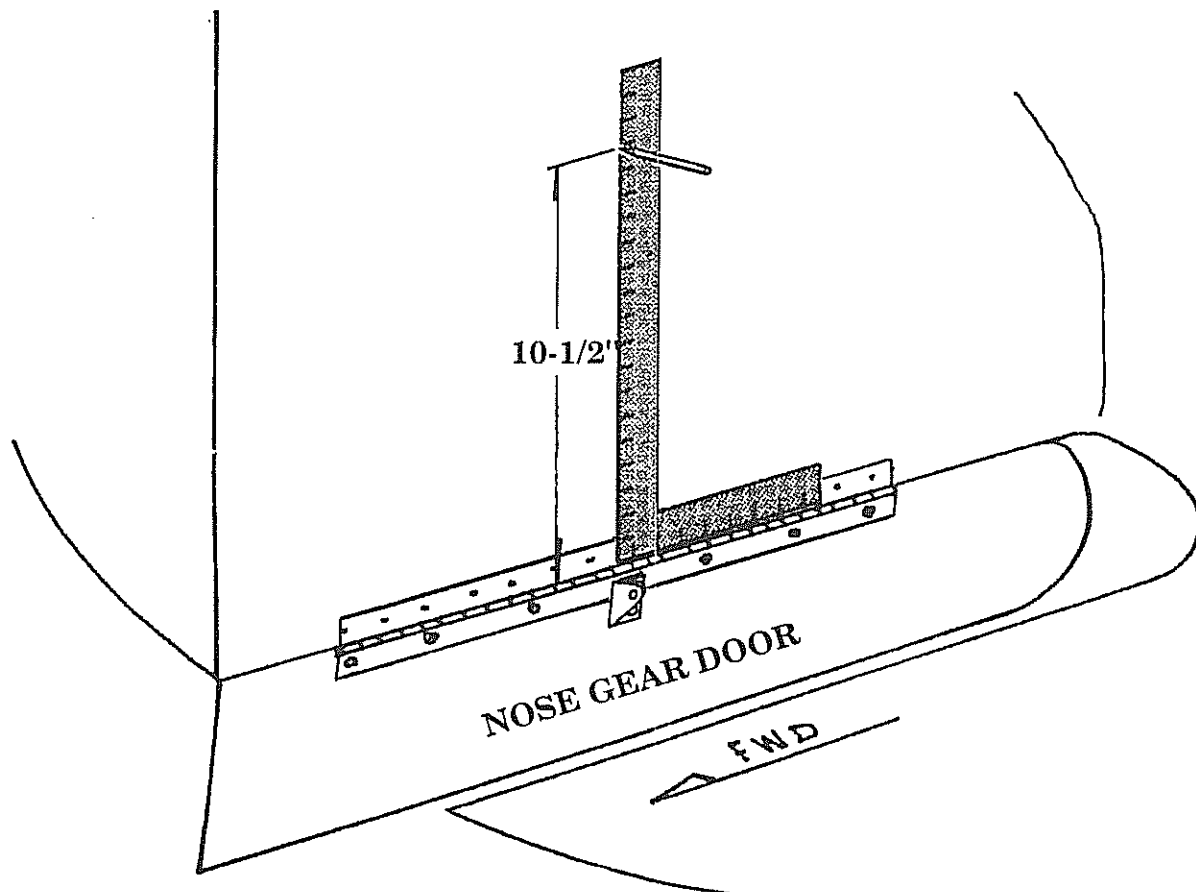

NOTE: Use the rod end bearing, attached to the "cylinder control horn" on the nose gear door, to establish the vertical center line of the actuating cylinder. Also be sure to align the carpenter's square along the *nose gear door hinge*, NOT the firewall (the firewall and the hinge are not perpendicular to each other).

1. Refer back to figures 6-14 on page 6-23 and figure 6-15 on page 6-24. It is important that the cylinder be located **perpendicular** to the hinge line of the door. Otherwise the cylinder shaft will bind at one point or another during cycling.
2. With the door held in position, locate the point where the cylinder control horn is attached (9-1/2" back from the L.E. of the door). See figure 6-14.

3. Place a carpenter's square along the hinge piece on the inside of the tunnel to establish the perpendicularity for the cylinder orientation. Mark a pencil line on the side of the tunnel for reference. See figure 13-3.
4. Locate a point 10-1/2" up from the bottom of the fslg, this will be the location for the attach bolt center that holds the door retract cylinder onto its brackets. Mark this as well. Check to verify that you are, indeed, ovetop of the 1/4" phenolic piece which was inserted onto the side of the nose gear tunnel during its assembly.
5. Per figure 6-16, make the two required brackets to attach the cylinder.
6. Position these brackets and drill the #12 through holes (4) and attach the two brackets. See figure 6-15.
7. Attach the gear door to the cylinder, see figure 13-2.

NOTE: It is advisable to create a mechanical "stop" for the retract cylinder when in the "door closed" position. This is to relieve the pressure exerted onto the door by the hydraulics. If this is not done, the door could slowly develop a bow due to the high pressures placed on it during retraction.

This "stop" can be easily made from the supplied piece of 7/16" dia. thin steel tubing. *Early Lancair kits were not supplied with this steel tube. If your kit does not contain the steel tube, please write and we'll ship it to you.*

Nose gear door cylinder "stop"

8. From the 7/16" steel tubing, cut a piece to slip over the shaft of the door cylinder. This will require some on and off trimming of the tube to establish the correct length. The tube itself will bottom out between the cylinder body and the bearing end cap. Fine adjustments can be made with the bearing itself however, that will affect the door angle when open. This door angle is not critical but must open beyond vertical.
9. To adjust the above "stop tube", first take the spring off the cylinder. Attach the bearing end to the door with about half of its threads engaged into the cylinder shaft. Close the door and from the fwd, open end of the tunnel (at the firewall), reach in and take a measurement of the shaft length with the door closed. This will be a good starting point for the tube length.
10. Saw the tube to length, file the ends smooth and slide it over the shaft, then replace the bearing with the machined spring aligner cap that slips over the shaft before the bearing.



11. Attach the bearing end to the gear door and again close the door. Reach into the tunnel and see if the tube is "snug" between the cylinder body and the spring aligner at the bearing end. The bearing can be adjusted somewhat to seal the door closed provided the door is allowed to extend beyond vertical when fully opened. If the door does not extend open beyond vertical, then the bearing will require less insertion into the shaft and the tube will require shortening to allow the door to fully close.

When the alignment is correct, the door will open past vertical and the door, when fully closed, will cause the tube to be snug between cylinder body and spring aligner. When this fit is satisfactory, snug up the check nut on the bearing - finger tight only.

12. Now remove the tube and note the location of the small through hole in the cylinder shaft (the bearings check nut will provide a notation for returning to the proper bearing location when the unit is re-assembled). The small through hole in the shaft is to allow you to slip a pin through (nail or whatever) which will hold the shaft from rotating so you can tighten the bearing check nut against the spring aligner. Now, since there is a tube over the shaft, you'll need to drill a hole in the tube at the approximate location so that you can access the hole in the shaft. This hole in the tube can be larger (1/8" dia.) so that it is not difficult to align (also, the tube will simply be floating on the shaft with the cylinder extended thus it should be easy to insert a pin through the assembly when tightening the check nut).

Fairing the nose gear door into the fuselage

14. Since the nose gear door sets ON the bottom of the fslg, it will require fairing. This is easily accomplished using micro. Close the door and apply a generous amount of micro around the perimeter. Taper this micro outward from the door about 3" - 4". Spread a smooth layer around then come back with the edge of a mixing stick, carved to a point, and run it around the edge of the door. This will form a separation in the micro around the door. Now you can carefully open the door and wipe off any micro that may have gotten under the door during application. Allow the micro to dry and then sand to blend.

Sequence valve for nose gear door

This sequence valve will route hydraulic fluid to the door retract cylinder, thus closing the door (the door is opened by the spring pressure alone which is created by the coil spring around the shaft).

15. Rotate the gear to the retracted position inside the tunnel. Note the tab on the right side of the GM27 weldment, it will be used to trip the sequence valve as the gear reaches full retract. It will require a small phenolic doubler on it to provide more surface area to contact the sequence valve shaft head, see figure 13-5. Note that this tab is the same one used to trip the gear "down" micro switch, see figures 5-36 and 5-37.



16. Make an attachment plate for the sequence valve per figure 13-4.
17. Temporarily attach the valve to the plate. The screw in the shaft should be in the middle range so it can be adjusted both in and out somewhat. Also be sure that there are sufficient threads for the check nut. Position this assembly in the tunnel to establish alignment with the GM27 tab. You can simply hold it with your hand while the gear is retracted. When the alignment is good, make a pencil reference mark around the plate.

WARNING: During alignment, it is very important to orientate the sequence valve such that the shaft is contacted and pressed "in line" with its natural plunging direction. **A side load on the shaft could bend it and cause a jam.** Take time to carefully position the sequence valve and align the valve shaft with the motion of the GM27 tab. See figure 13-5.

Attachment plate, sequence valve
(Nose gear)
Figure 13-4

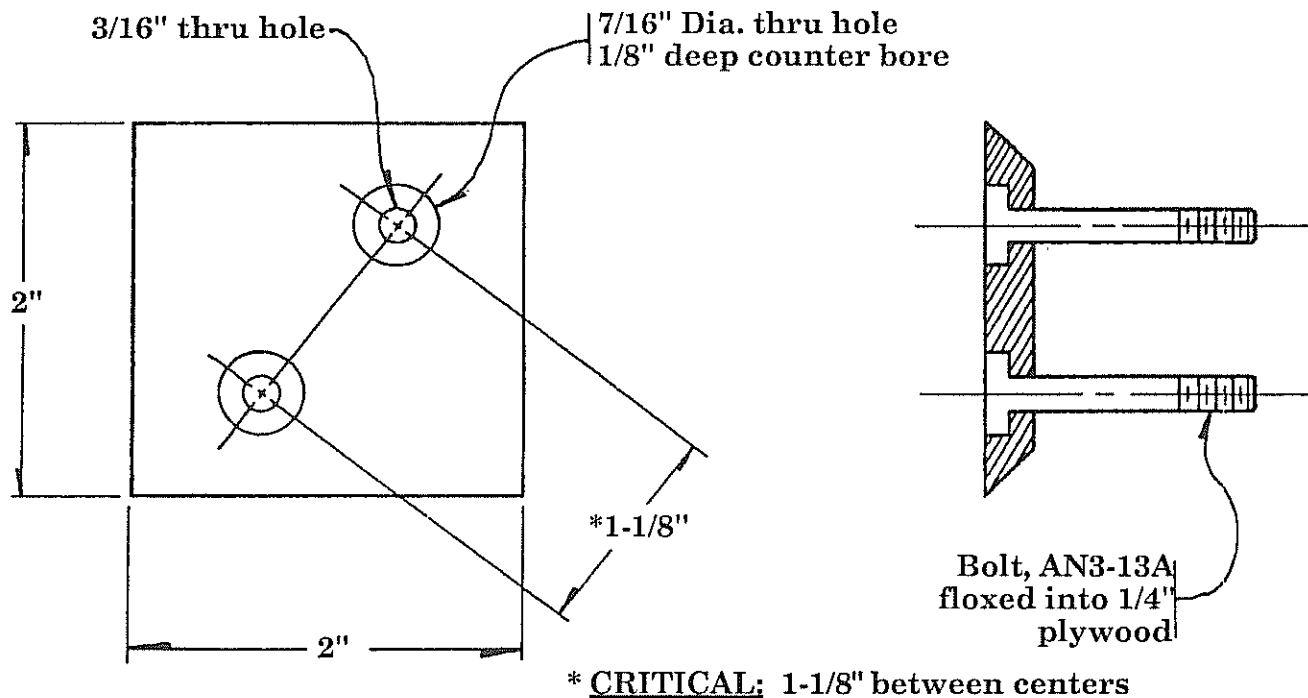



18. Now, clean the surface of the nose gear tunnel where you placed the reference pencil marks for the sequence valve attach, but be careful to not loose your reference marks. Bond the plate to the side of the tunnel wall using the pencil marks as a reference. Use epoxy/flox under the plate and add 4 BID over it. Cover the two bolts with tape to protect their threads from epoxy. The 4 BID must contact the tunnel walls 1.5" - 2" all around the plate.
19. Per figure 13-5, insert the hydraulic fittings into the sequence valve prior to permanently mounting it to the tunnel wall.

WARNING: It is very important that the sequence valve ports are correctly established. The valve will not operate properly if you put the lines into the wrong ports on the valve. See figure 13-5 for proper orientation of hydraulic lines. The "out" port is the one nearest the plunger shaft. The "out" line connects to the retract cylinder.



Positioning the nose gear sequence valve & micro switch

Figure 13-5

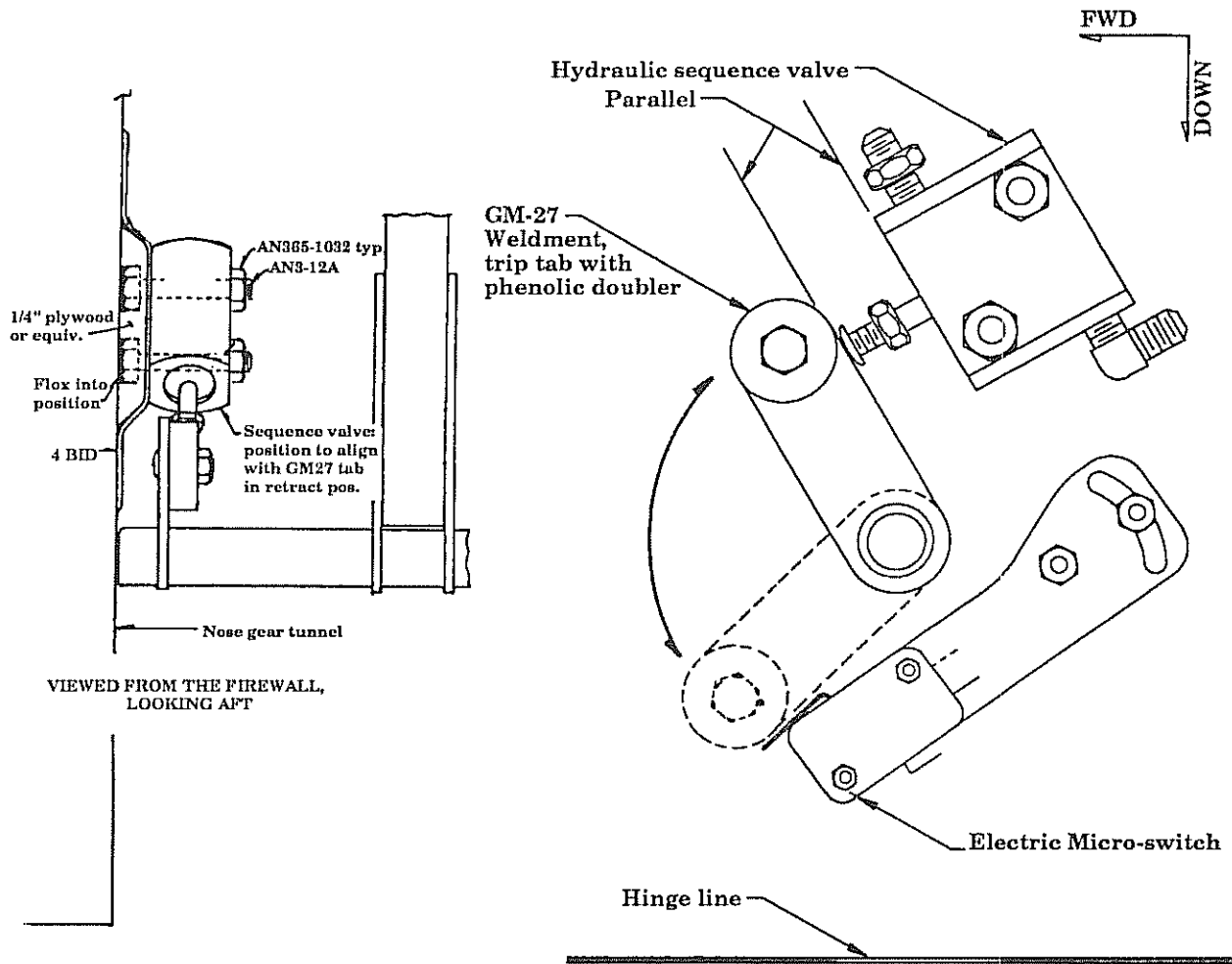

C. Main gear doors - adjustments

The main gear have three doors each, which were cut from the belly pan. The outbd door hinges on the lower wing near BL-50 and is driven with the short push rod connected directly to the gear strut. The middle door is attached directly to the gear casting. The inbd door is attached via piano hinge to the belly pan / cockpit closeout rib and driven either mechanically, via a cable system, or optionally via hydraulics.

Main outbd gear door adjustment

Before the doors can be adjusted, the gear up stop must be established.

1. Refer to the push rod shown on figure 5-19. First set the rod to the 3-1/8" dimension shown. Attach it and slowly move the gear up into the well by hand. Note when the gear door closes, if the gear leg is not all the way up into the well, then the push rod will have to be lengthened. If the gear is fully into the well and the door is still cracked open, then shorten the rod.

WARNING: It is important to not only have the gear door tight *enough* but to also NOT have it too tight. If the door is too tight, the gear hydraulics will easily overpower the doors stiffness and eventually deform the door and possibly cause an attachment failure. An attachment failure could then lead to a jam and prevent the gear from extending down and locked.

Main gear middle door adjustment

2. Refer to page 6-14, Main Gear Middle Doors. The middle gear door is attached directly to the gear casting using three machine screws. The upper door adjustment is made by sizing of the bushing on the upper machine screw. This will move the top of the door panel either inward or outward from the gear casting.
3. The lower end of the door is adjusted by bending the aluminum attach plate or shimming under the two lower machine screw holes.

NOTE: As the gear starts down from the fully retracted position, there is a near "sliding" motion where the outbd door "slides" past the middle door. Often this action requires some sanding along that mating line between those two doors so that the outbd door does not get caught on the middle door. If required, sand a bevel onto the edge of the middle door adjacent to where the outbd door aligns.



Main gear inbd door actuation and adjustment

There are two methods of actuating the inbd gear doors. One method is "mechanical" via a cable. The other method is "hydraulic" via small actuating cylinders (the same cylinder type with sequence valve as used for the nose gear door system). The differences can be broken down to cost and reliability. Inbd gear doors are notorious for requiring constant adjustment since they are usually mechanical in nature. That is why we developed an optional "hydraulic" system. It is absolutely "positive" and once adjusted, will not require further adjustments.

D. Mechanical inbd door system

Refer to blueprint "L"

1. This cable operated mechanical system will operate directly off the main gear leg tab as shown on blueprint "L".
2. First locate on the cockpit closeout rib, the installation point for the 1/4" plywood (or phenolic) blocks. You will need to check for clearance from the tire when retracted and also from the aileron push rod. The clearances are rather close so a fit check is definitely required.
3. It is best to first make the control horn assembly which will fit between the two 1/4" plywood pieces so this assembly can be used to size the actual installation of the 1/4" plywood.
4. Cut out the two inner gear door bellcranks per blueprint "L". Note that one will require the #30 hole drilled into the tab while the other will not require the tab at all. This tab will pick up the spring. Use the 3/8" x .083" aluminum tubing as shim stock to space the bellcranks properly, per blueprint "L". This shim stock will first require drilling out with a 1/4" bit to accept the AN4-23 bolt (a .250" reamer is actually best for this operation).
5. Bond the 1/4" plywood pieces onto the cockpit closeout rib using 4 BID per side as indicated on blueprint "L". A dab of hot glue or instant glue in the corners will hold the pieces until the BID is applied.
6. Make and install the inner gear door control horn for the inbd gear doors per blueprint "L".
7. Make and install the gear door push rod by tapping a 1/4-28 thread into the 3/8" x .083 tubing at both ends. Position the M34-14 rod ends in their approximate mid range adjustment positions.
8. Start with the gear door in the vertical (open) position and the bellcrank assembly just over center in its travel rotation. The MS24694-S82 machine screw should be installed and will serve as the "stop" for this overcenter bellcrank when the spring pulls on it.

9. Attach the cable to the bellcrank assembly with a nico press sleeve and thimble. **Use only nico press clamps to set these nico press sleeves.** Run the cable through a length of nyla-flow line per blueprint "L". This line will be bonded to the inner, upper wing skin in a position such as to provide a clean straight pull from both ends (bellcrank and gear leg). This will require a slight "S".

NOTE: The nyla-flow line should be terminated in an aligning manner with the direction of pull on the cable (similar to the approach used when routing the rudder cables and guide tubes). See blueprint "L" for a depiction of this termination style. This will require a slight raising of the nyla-flow line at each end. A little micro will work well to form a slight ramp as shown on blueprint "L". Also see figure 13-6. Use dabs of hot or instant glue to temporarily position the line. Cover and secure it with 2 BID overtop.

Cable exit ramp, Nyla-Flow guide tubing

Mech. inbd gear door system

Figure 13-6

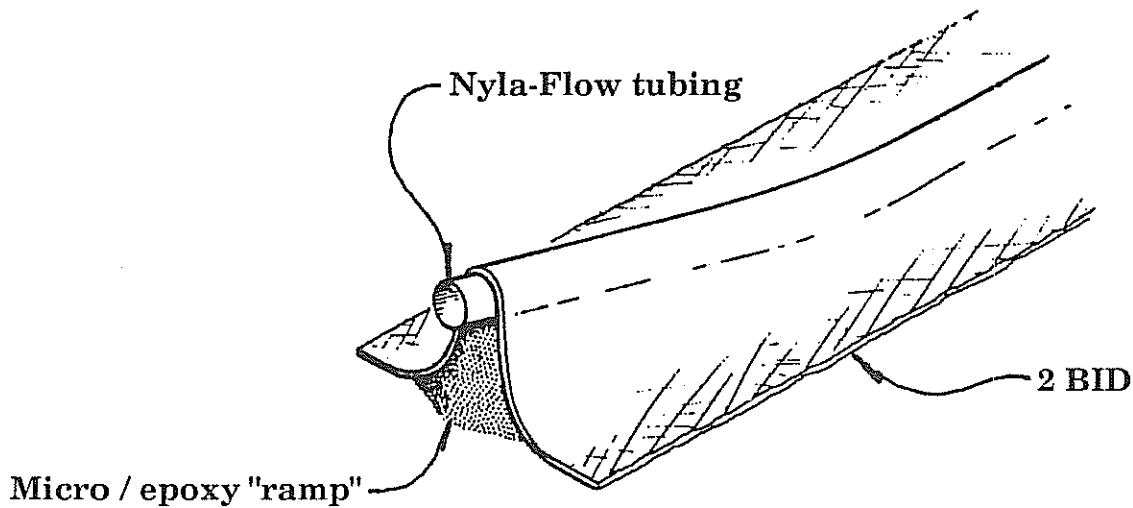

MECHANICAL INBD GEAR DOOR SYSTEM SHOWN INVERTED

Figure 13-7

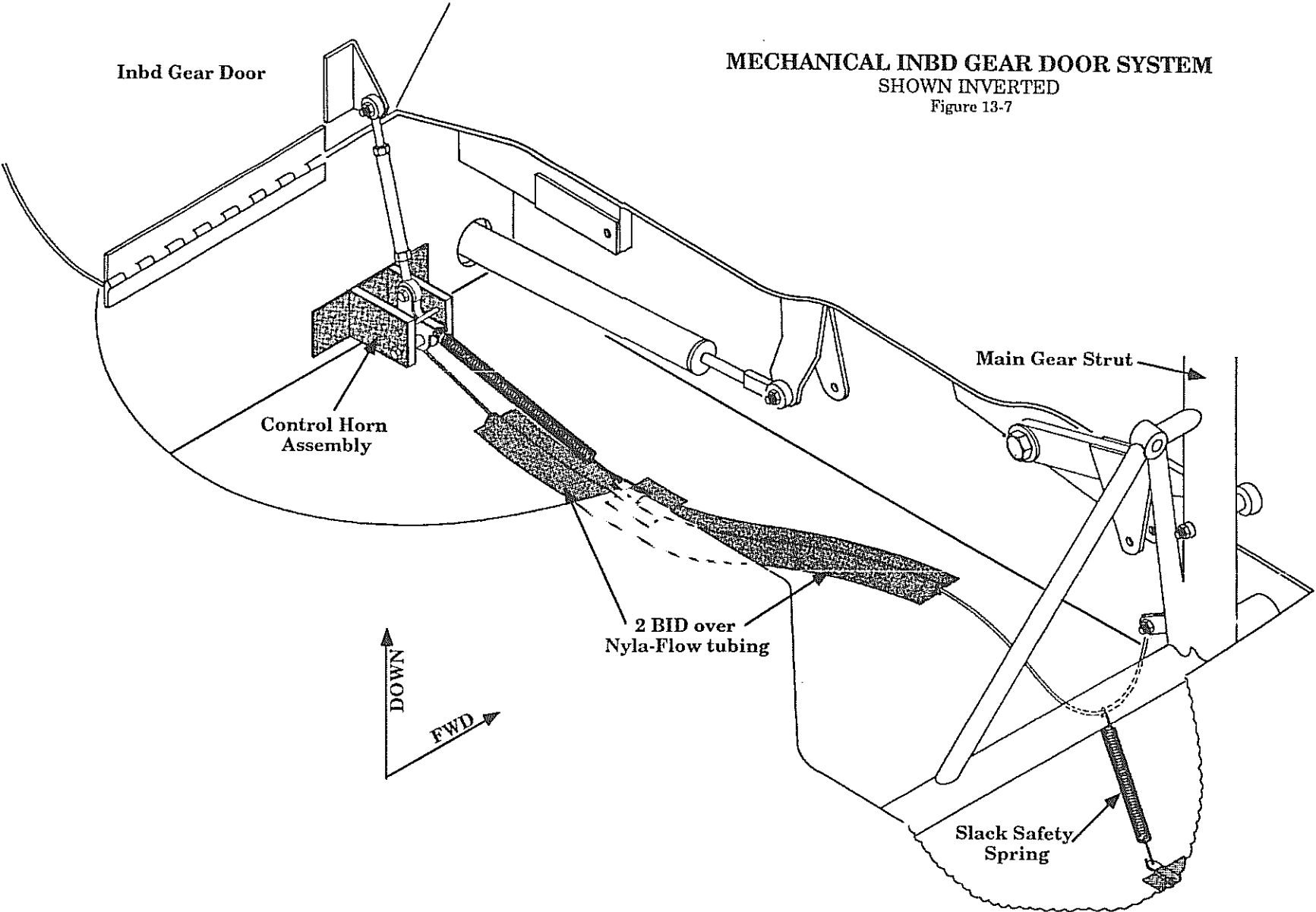

Lanair International Inc. Copyright © 1991, Redmond, OR 97756

JANCAIR® 320FTB

13-20

Chapter 13
GEAR & GEAR DOOR ADJUSTMENTS

REV. 0 / 11-1-91



WARNING: The cable will become slack as the gear extends down and the door opens. It may be necessary to attach a light spring to pull the slack cable and keep it away from the landing gear mechanism. See figure 13-7.

10. Prior to adjustment, remove the other two gear doors.
11. Retract the gear fully, close the inbd gear door tightly and pull the cable as tight as possible. Mark the cable at the gear leg end where it will attach to the tab on the leg. If you temporarily attach any bolt through the tab hole, then the cable can be pulled around that bolt from outside the wing box. This will make the measuring process a little easier. A piece of masking tape on the cable will make locating a reference mark a little easier as well. This is probably the toughest part of this whole installation.
12. With a reference mark made on the cable at the point where it will attach to the gear leg tab, install an AN111 thimble and nico press sleeve such that the dimension is approximately 1/4" shorter than marked previously. This will help account for the expected cable stretch and thus the required tension on the door will be achieved. (The tension desired is quite higher than your ability to pull on the cable.)
13. With the nico press sleeve attached, connect the unit and first back off one of the M34-14 rod end bearings about 1/4" prior to running the gear up for the first time with the door closure mechanism attached. Adjust this rod end as necessary until the door fits tightly with the gear all the way up (it's better to start loose and work your way up to a tight condition). When you are finished, the gear door would likely be positioned at an angle that is less than vertical - this is acceptable provided the gear clears by at least 1/4" - 3/8" at all positions.

Tightening up on the bearings (shortening the push rod) will of course tighten the door when closed but it will also leave it in a position which is less open when the gear is down. It is conceivable that this could take a couple of tries to get it right.
14. Attach the #5566 spring onto the door bellcrank and in the gear down (door open) position pull the spring (thus pulling the bellcrank assembly against the overcenter stop) to achieve the 7" dimension of the spring shown on blueprint "L". Mark this location on the upper wing skin. Check that the spring location will not interfere with the tire when retracted and adjust accordingly.
15. Check that the spring does in fact pull the bellcrank assembly overcenter thus locking the gear door pushrod in the open position. This is essential in preventing the door from partially closing and getting caught by the tire as it retracts into the well.

16. This door system will require periodic adjustment as the cable will always have a tendency to stretch and the gear tab will flex slightly. Thus, the aircraft should be jacked up periodically and the gear retracted to check for proper closure.



13-22

Chapter 13	REV.	0 / 11-1-91	
GEAR & GEAR DOOR ADJUSTMENTS			

E. Hydraulic inbd main gear door system (optional)

This system will operate the main gear inbd doors via hydraulic pressure in a manner that is very similar to that used for the nose gear door. This optional system is much more positive, provides increased up load to hold the door shut during high speed cruise and requires virtually no adjustment after installation is completed. See figure 13-9 for hydraulic system drawing.

1. See blueprint "L" for installation drawings of this system. Locate and cut the access hole through the cockpit closeout ribs having first checked to verify that there will be sufficient clearances from the tire for the control horn which mounts to the inner gear door. There is some room for placement fwd / aft to aid in achieving adequate clearances. This control horn is designed to pass through the cockpit closeout rib just fwd of the piano hinge attachment. The cylinder will attach on the FWD face of the control horn to provide maximum clearance from the tire. Adjust the through hole in the closeout rib accordingly.
2. Fabricate and attach the control horn per blueprint "L" to the inner gear door. Note that there is a build up of BID under this control horn so as to achieve a flat surface. The control horn will also rest on top of the piano hinge section.

NOTE: The distance (radius) generated between the piano hinge center and the attachment hole in the end of the control horn is important. See blueprint "L", that dimension must be maintained to within 1/16". Placement of the control horn on the door will establish this dimension.

3. With the control horn attached, the small door retract cylinder will next be located. The cylinder **MUST** be positioned on the fslg floor (under the seating area) such that it's line of piston shaft travel is perpendicular to the piano hinge line of the door. Use a small carpenter's square against the inner side of the cockpit closeout rib to establish line of perpendicularity. See figure 13-8.

Positioning the retract cylinder

(Hydraulic inbd gear door)

Figure 13-8

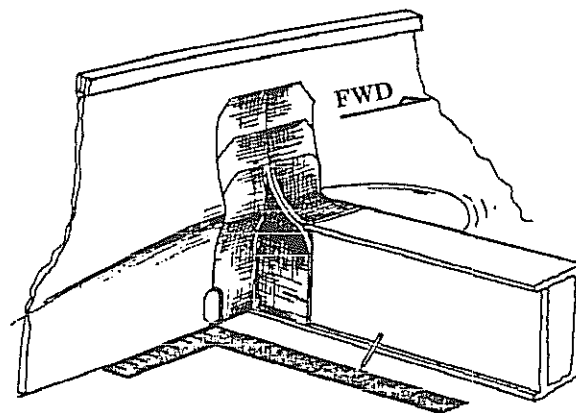

**HYDRAULIC INBD GEAR DOOR SYSTEM
(SHOWN INVERTED)**

Figure 13-9

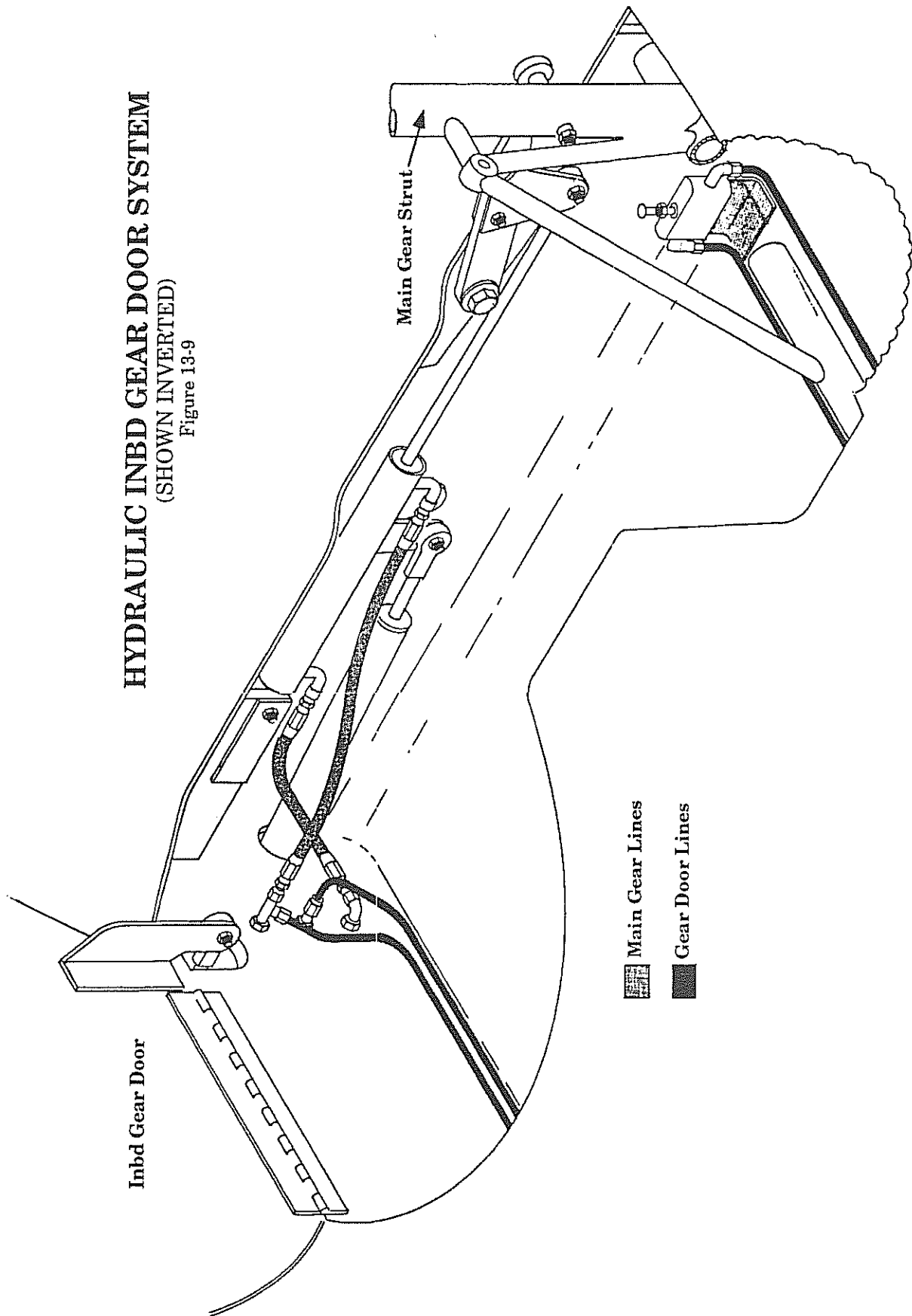

Main Gear Lines

Gear Door Lines

4. Before locating the mounting position of the cylinder attachment, the bearing on the end of the shaft must be securely positioned (the bearing, check nut and spring are only temporarily positioned for ease of shipping when they leave our stock room and the check nuts are not secured).

To secure the check nut and locate the rod end bearing, first remove the bearing from the shaft. With it off, position the check nut such that it provides for 5/16" of insertion into the shaft. This can be set by simply positioning the check nut 5/16" from the end of the threaded end of the bearing. Next, compress the spring by firmly grasping it and pulling down toward the cylinder base. Screw the bearing into the end with the check nut remaining in the pre-selected location. (Be sure that the spring retainer is also positioned.) Set the check nut by tightening it against the piston shaft. Hold the shaft from rotating by slipping a small pin through the hole drilled into the shaft.

5. To locate the cylinder assembly attach point on the fslg floor, temporarily attach the cylinder to the door control horn using an AN3 bolt. Locate the bearing on the FWD face of the door control horn. The through hole in the cockpit closeout rib can be ground to accommodate the passage of the shaft assembly.
6. Place the gear door in the open position. (The ideal open position is from vertical to not more than 3° short of vertical.)
7. Next place the cylinder base on the line which was made on the fslg floor that represents a perpendicular alignment to the door piano hinge.
8. Mark the location for the AN3 attachment bolt that will hold the cylinder assembly to its two attach brackets. Mark this reference line on the floor. Remove the cylinder assembly.
9. Fabricate and install the two attach brackets for the cylinder assembly per blueprint "L". This will require a BID lay up on the floor and then a BID lay up over the brackets per blueprint "L".
10. Next locate the sequence valve attachment location on the upper stub wing skin, see figure 13-10. This can be located by simply holding the gear in the retracted position and having someone position the valve and mark its relative position onto the inner wing skin surface. This alignment point should be such that the plunger shaft is contacting the vertical member of the GM1 weldment at dead center.

WARNING: the location of the valve plunger assembly is critical and should not be more than 1/16" off dead center on the GM1 weldment. Failure to establish this tolerance could result in gear system damage and / or failure.



11. With the location marked, extend the reference marks far enough out so that the next BID ply lay ups will not hide them and you will thus be able to re-establish this location.
12. Add the BID lay ups to the skin first per blueprint "L".
13. Next add the 1/4" plywood (or phenolic) attach block and add the BID lay up schedule to it as well. See figure 13-11. Use either 5 min. epoxy or instant glue or a couple of dabs of hot glue to hold the blocks in position until the floc cures. When positioning the block, be sure to account for the thickness of the valve body itself since it will bolt up to ONE SIDE of the block thus the plunger center will be displaced that equivalent distance.

NOTE: This installation is a lot easier if the airframe is in the inverted position.

Positioning the main gear sequencing valve

(Shown inverted)

Figure 13-10

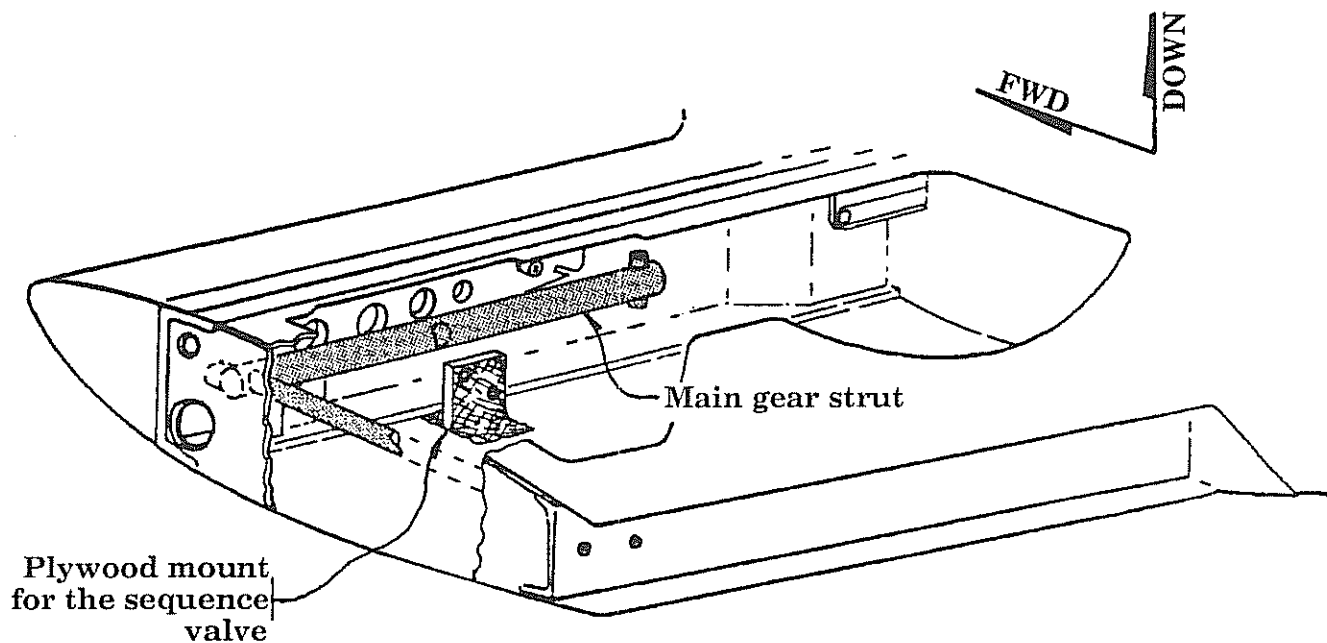



14. After cure, reposition the sequence valve. Set the small screw in the plunger shaft at a position that is about mid way in its available travel range. This will allow maximum potential adjustments after the valve is permanently located. Note the distance of travel required of the plunger (about 0.100"). Have someone hold the gear in the full retract position and with the valve placed against the attach block, locate it so that it contacts the GM1 at dead center of its diameter and also adjust the valve vertically such that the plunger is fully depressed when the gear is retracted. Mark this position on the attach block.
15. Now you can allow the gear to extend back down (getting it out of the way) and reposition the valve to the reference marks. Then drill for the two AN3 attachment bolts using a #12 drill bit.
16. Attach the valve and recheck plunger travel and alignment by retracting the gear by hand.

WARNING: Be absolutely sure that the plunger is not adjusted too long. If it were, then the gear leg would place its full pressure against the bottomed out plunger. This could either damage the valve assembly or possibly create a bulge in the upper wing skin at this location. The plunger should have just a few thousands of an inch of free play with the gear fully retracted.



Attaching the main gear sequence valve

(shown inverted)

Figure 13-11

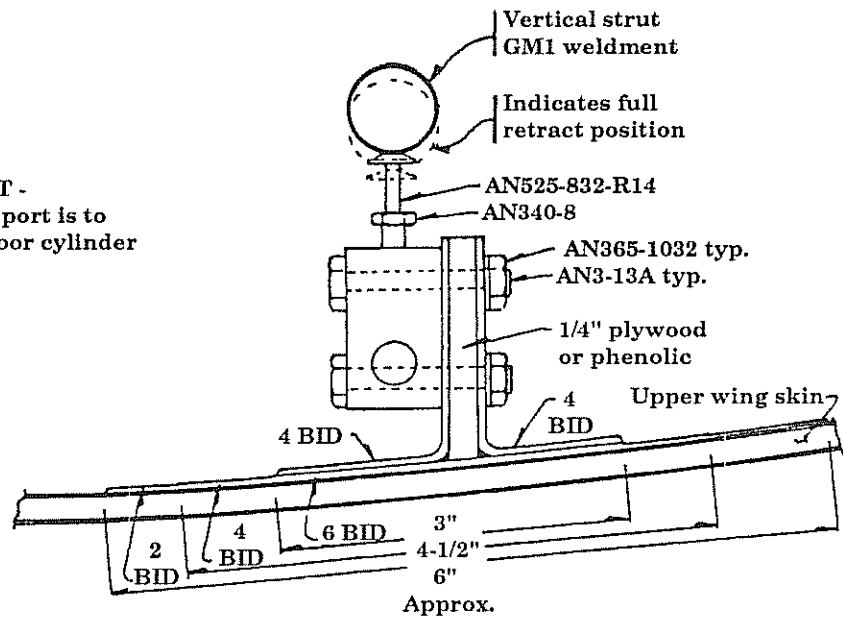
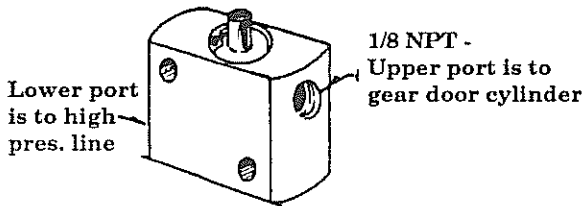
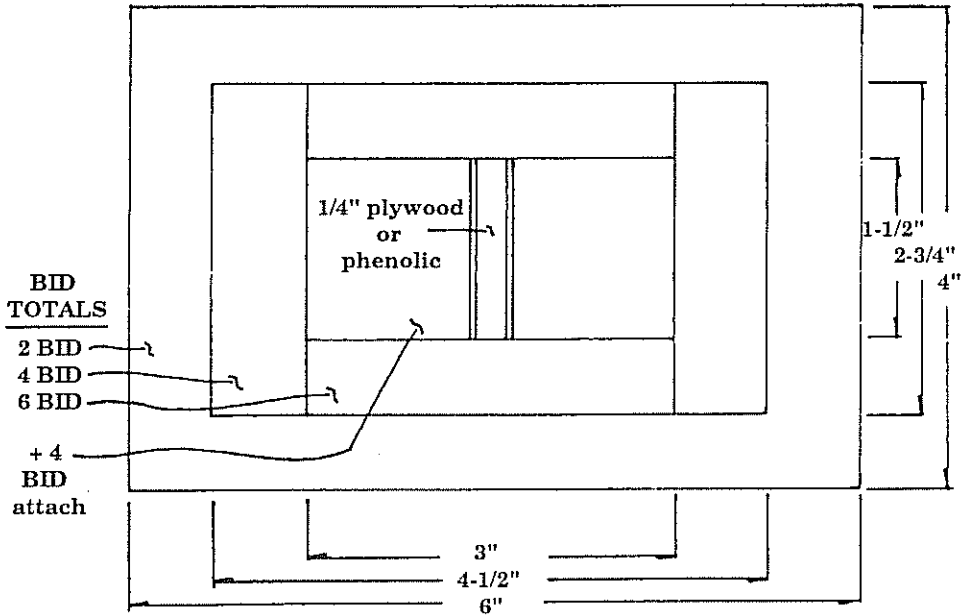

CHAPTER 14 REVISION LIST



The following list of revisions will allow you to update the Lancair ES construction manual chapter listed above.

Under the "Action" column, "R&R" directs you to remove and replace the pages affect by the revision. "Add" directs you to insert the pages shown and "R" to remove the pages.

Page(s) affected	Current Rev.#	Action	Description
14-1 thru 14-9	0		
14-10	6	R&R	Modified figure 14-3, added fig. 14-3a
14-11	6	R&R	Modified figure 14-4a
14-11a	6	Add	New style power pack
14-12 thru 14-34			
14-35 thru 14-36a	5	R&R	Rewrote section, changed figures
14-37 thru 14-44	0		



14-i

Chapter 14

6/4-1-99

LANDING GEAR



CHAPTER 14: LANDING GEAR

FINAL ELECTRICAL & HYDRAULIC INSTALLATIONS

REVISIONS

From time to time, revisions to this assembly manual may be deemed necessary. When such revisions are made, you should immediately replace all outdated pages with the revised pages. Discard the out dated pages. Note that on the lower right corner of each page is a "revision date". Initial printings will have the number "0" printed and the printing date. All subsequent revisions will have the revision number followed by the date of that revision. When such revisions are made, a "table of revisions" page will also be issued. This page (or pages) should be inserted in front of the opening page (this page) of each affected chapter. A new "table of revisions" page will accompany any revision made to a chapter.

Arrows

Most drawings will have arrows to show which direction the parts are facing, unless the drawing itself makes that very obvious. "A/C UP" refers to the direction that would be up if the part were installed in a plane sitting in the upright position. In most cases the part shown will be oriented in the same position as the part itself will be placed during that particular assembly step. However, time goes on and changes are made, so careful attention should be paid to the orientation arrows. That old cartoon of the guy agonizing over the plans for his canoe, built one end up, one end down, should not happen in real life. Especially to you.

CONTENTS

1. INTRODUCTION
2. DRAWING LIST
3. SPECIAL PARTS, TOOLS & SUPPLIES LIST
 - A. PARTS
 - B. TOOLS
 - C. MATERIALS & SUPPLIES
4. PROCEDURE
 - A. POWER PACK & PRESSURE SWITCH INSTALLATIONS
 - B. GEAR FREE-FALL VALVE INSTALLATION
 - C. BASIC HYDRAULIC LINE FABRICATION TECHNIQUES
 - D. FLEXIBLE HYDRAULIC LINE FABRICATION
 - E. ALUMINUM HYDRAULIC LINE FABRICATION
 - F. INSTALLING THE GEAR HIGH AND LOW PRESSURE LINES
 - G. FLEXIBLE LINE INSTALLATIONS
 - H. GEAR ELECTRICAL INSTALLATIONS: GEAR SWITCH
 - I. GEAR DOWN LIGHTS
 - J. GEAR TRANSITION LIGHT
 - K. GEAR MICRO SWITCHES - MAIN GEAR
 - L. NOSE GEAR MICRO SWITCH
 - M. GEAR MICRO SWITCH WIRING
 - N. GEAR PRESSURE SWITCH WIRING
 - O. GEAR WIRING SCHEMATIC
 - P. GEAR SYSTEM START UP / TEST OPERATIONS: ADDING HYDRAULIC FLUID
 - Q. START UP OF HYDRAULIC GEAR
 - R. PRESSURE SWITCH ADJUSTMENT
 - S. FREE-FALL TEST
 - T. IN-FLIGHT FREE FALL TESTING

1. INTRODUCTION

Refer back to chapter 5, page 5-50, "Gear hydraulics", which began a section that primarily addressed the installation of the cylinders themselves. This section will address the hydraulic and electrical connections that will make it all operate correctly. Note that there will be some beginning duplication used here which might help get you back to the right train of thought.

The landing gear itself should now be fully installed, with the completion of this chapter, you'll be able to make it go up and down by itself. The electro-hydraulic system that actuates the landing gear, although perhaps appearing to be complex at first glance, is actually very simple and straight forward in its design. As with all systems, they can be designed in a variety of ways. The choices for the Lancair have all placed a strong emphasis on simplicity and reliability.

There are essentially two sides to the system, the UP side and the DOWN side. Another way of describing them is via pressures, i.e., high pressure (UP) and low pressure (DOWN). The pressures are achieved via an electric motor and small gear pump. This is a self-contained unit that combines the motor, pump and reservoir in one compact 6 lb package.

HIGH PRESSURE SIDE: The high pressure lines will always attach to the retract cylinder port that is nearest to the shaft of that cylinder. All cylinders on the Lancair "retract" their shafts into the cylinder body when the gear is retracted or the gear doors are closed. This side of the system will operate at pressures of about 1,100 psi.

LOW PRESSURE SIDE: The low pressure lines will always attach to the cylinder port that is farthest away from the shaft of the cylinder. This side of the system will push the gear down & locked and open the appropriate gear doors. There is less operating pressure used for gear down functions, about 550 psi.

SAFETY BACKUP: There is a built in safety backup system in the event of a hydraulic or electrical system failure - it is the FREE FALL ability. The landing gear will usually free fall down and locked faster than it can be pumped down since the hydraulics tend to act as a restrictor as the gear extends down and locked.

The high pressure and low pressure sides of the system will never be mixed or connected except at the free-fall valve. This valve will normally remain closed. If electrical power is lost for any reason, the free-fall valve can be opened and the gear will automatically drop down & lock. All gear legs are spring loaded to the down & locked position.

When this free-fall valve is opened, it essentially allows fluid from the high pressure side to flow across to the low pressure side thus allowing the gear to drop down and the spring loads lock it down.



2. DRAWING LIST

Drawing	Page	Title
14-1	8	Schematic - landing gear hydraulics (mech. inbd gear door)
14-2	9	Schematic - landing gear hydraulics (hydraulic inbd gear door)
14-3	10	Attach plate
14-4	11	Hydraulic power pack installation
14-5	12	Gear Free-fall valve mount bracket & assembly
14-6	13	Gear Free-fall valve placement
14-7	14	Flexible hydraulic line fabrication
14-8	18	Hand bending aluminum hydraulic line
14-9	20	Anchor points for aluminum hydraulic line
14-10	21	Bulkhead fitting installation for hydraulic line
14-11	23	Stub wing installation of hydraulic lines
14-12	24	Hydraulic line routing inside the nose wheel tunnel
14-13	26	Wiring - landing gear switch
14-14	27	Gear "quadrant" location
14-15	31	Micro switch installation, main gear
14-16	33	Micro switch wiring connections
14-17	36	Wiring schematics



3. EQUIPMENT REQUIRED - SPECIAL PARTS, TOOLS & SUPPLIES

A. Parts

- Hydraulic power pack
- Pressure switch (high)
- Pressure switch (low)
- Starter relay (2)
- A/C master relay
- 50 Amp circuit breaker
- Attach plate
- Gear free-fall valve
- Gear switch
- Gear "quadrant"
- Gear micro switches (3)



B. Tools

- Sharp utility knife
- Bench vise
- drill motor
- drill bits: 7/16"
- 9/16" wrench (2)
- Pencil
- Flaring tool, 37°



14-5

Chapter 14

REV. 0 / 11-1-91

LANDING GEAR

C. Materials & supplies

- epoxy
- flux
- BID cloth
- micro
- sandpaper, assorted grit
- Duct tape or release tape
- MC or acetone for cleaning
- 1/4" 5052-0 rigid line aluminum tubing
- HR 303 flexible hose Alternate Part number R703



NOTE: It is hopefully obvious, and already settled upon, as to the choice regarding the optional hydraulic gear door system for the main gear. The basic hydraulic installations are essentially the same with some additions used with the hydraulic gear door option.

4. **PROCEDURE**

A. **Power pack & pressure switch installations**

1. Review pages 5-59 and 5-60 in chapter 5, "Hydraulic power pack installation". Per figure 14-3, this attach plate is highly recommended as a very convenient means of assembling all the elements as shown in figure 14-4.
2. The power pack, as discussed above, is a self contained unit comprised of three elements: electric motor, gear pump and reservoir. This pack is attached to the aft face of the baggage bulkhead. The pressure switches will also be located there as will the two starter relays that operate it.
3. It is also recommended that you install the MASTER RELAY for the aircraft's full electrical system at this same location. See figure 14-4.
4. A 50 amp circuit breaker must also be used with this system and, per figure 14-4, the location is best suited near the power pack. This will place the circuit breaker in the baggage bulkhead.
5. Now go back to the power pack and install the two short lines from the AN826-4D fittings that are screwed into the power pack ports. These lines will extend vertically and attach the pressure switches.
6. Attach the pressure switches to the above lines.

WARNING: Be very careful in marking the pressure switches for "high" and "low" since once you remove the switches from their marked packets, they will look the same. Put a marking system onto them immediately as you remove them from their packets. If you mix the order, the system will not operate.

SCHEMATIC - LANDING GEAR HYDRAULICS STD. - MECH. INBD GEAR DOOR

FIGURE 14-1

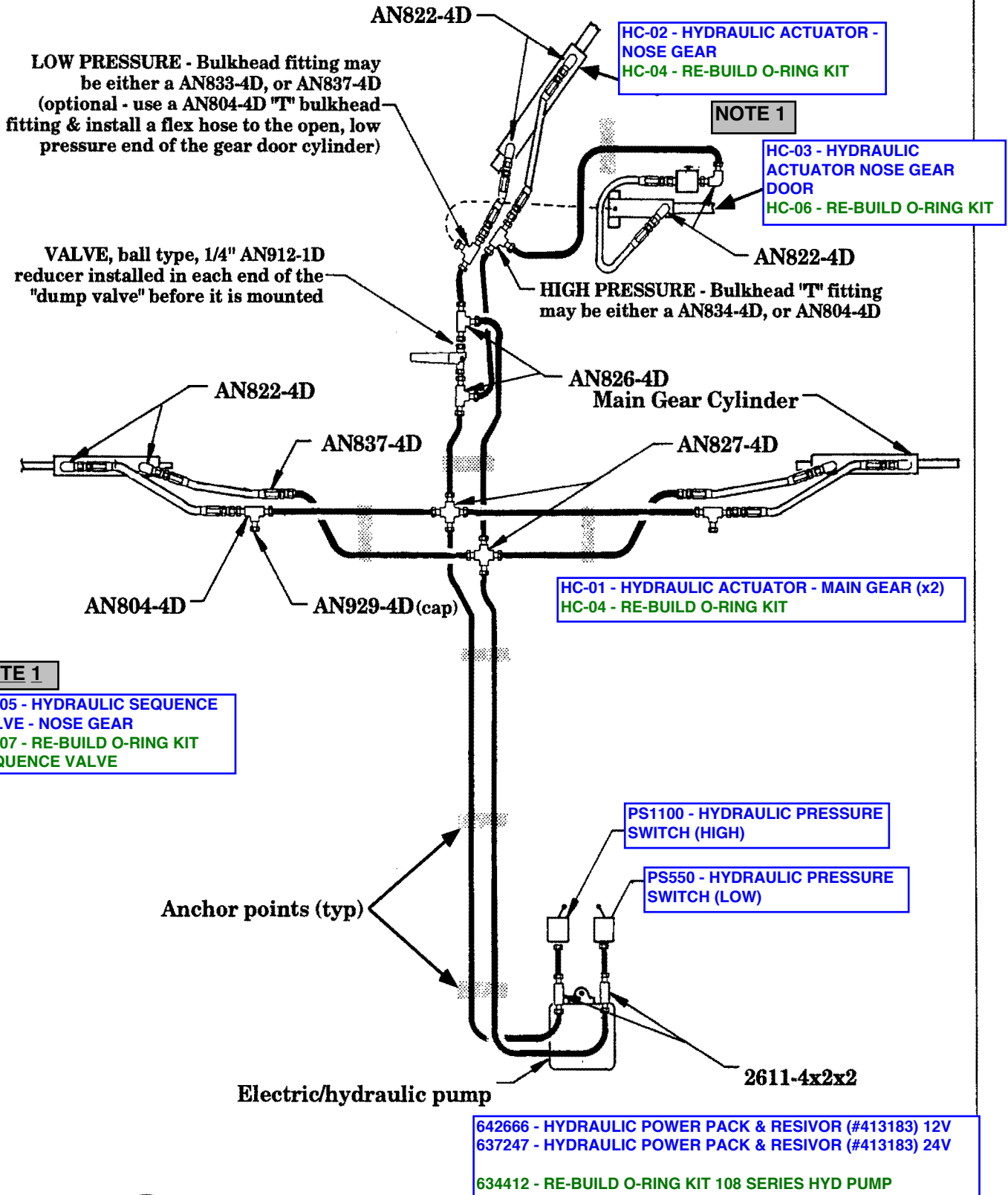

Old style with small black wire

(Hydraulic power pack assembly)

Figure 14-3

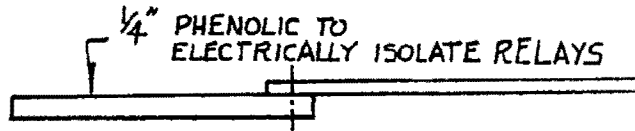
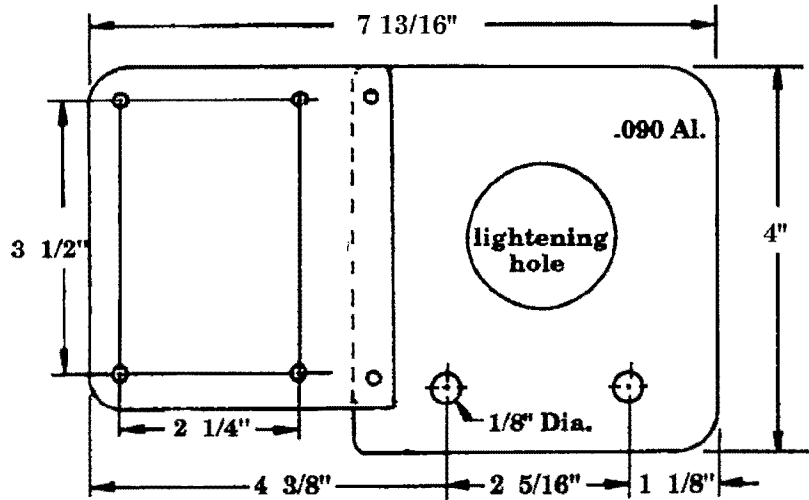

New style with large black wire

Figure 14-3a

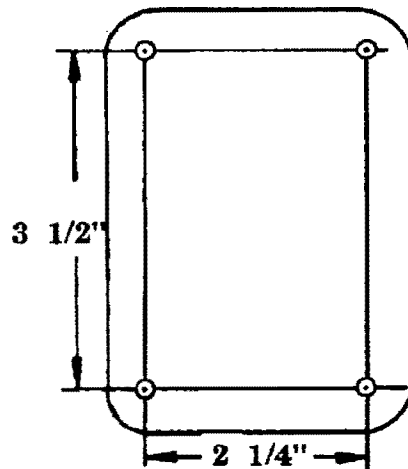

Note: No metal plate is needed under pump.

Hydraulic Power Pack Installation

Old Style
Figure 14-4a

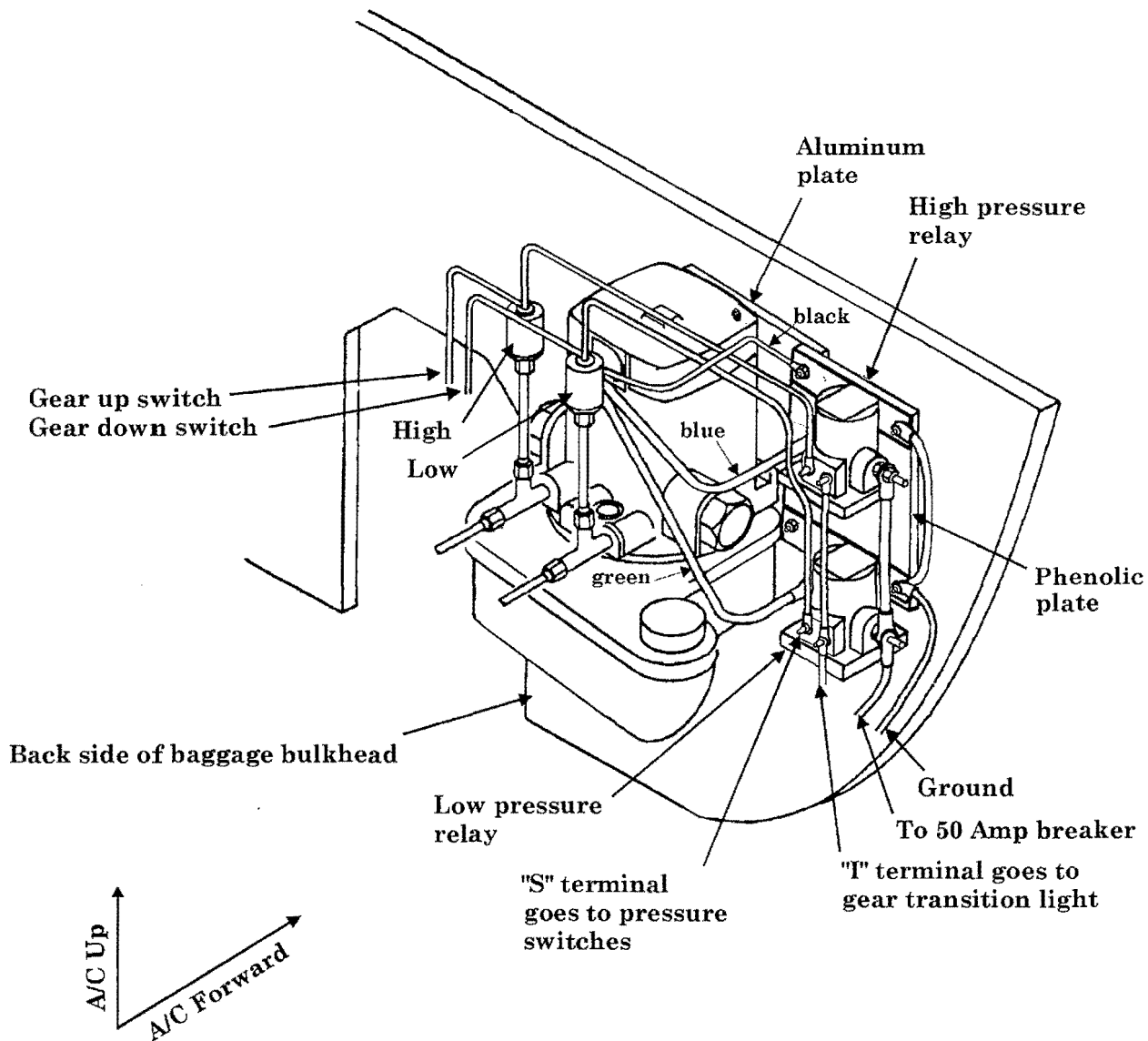

Hydraulic Power Pack Installation

New Style
Figure 14-4b

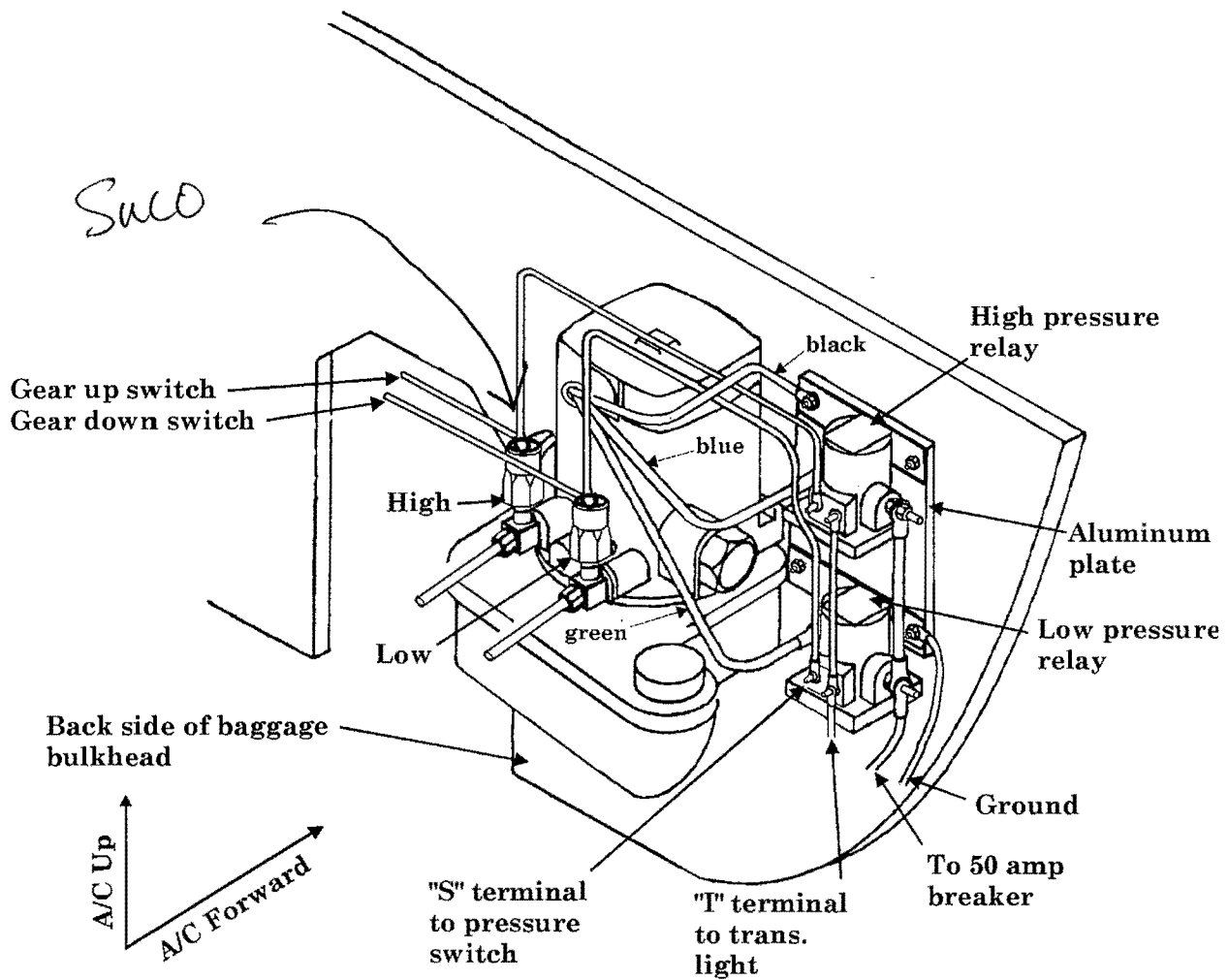

HYDRAULIC POWER PACK INSTALLATION

(VIEW: AFT SIDE OF BAGGAGE BULKHEAD)

Figure 14-4

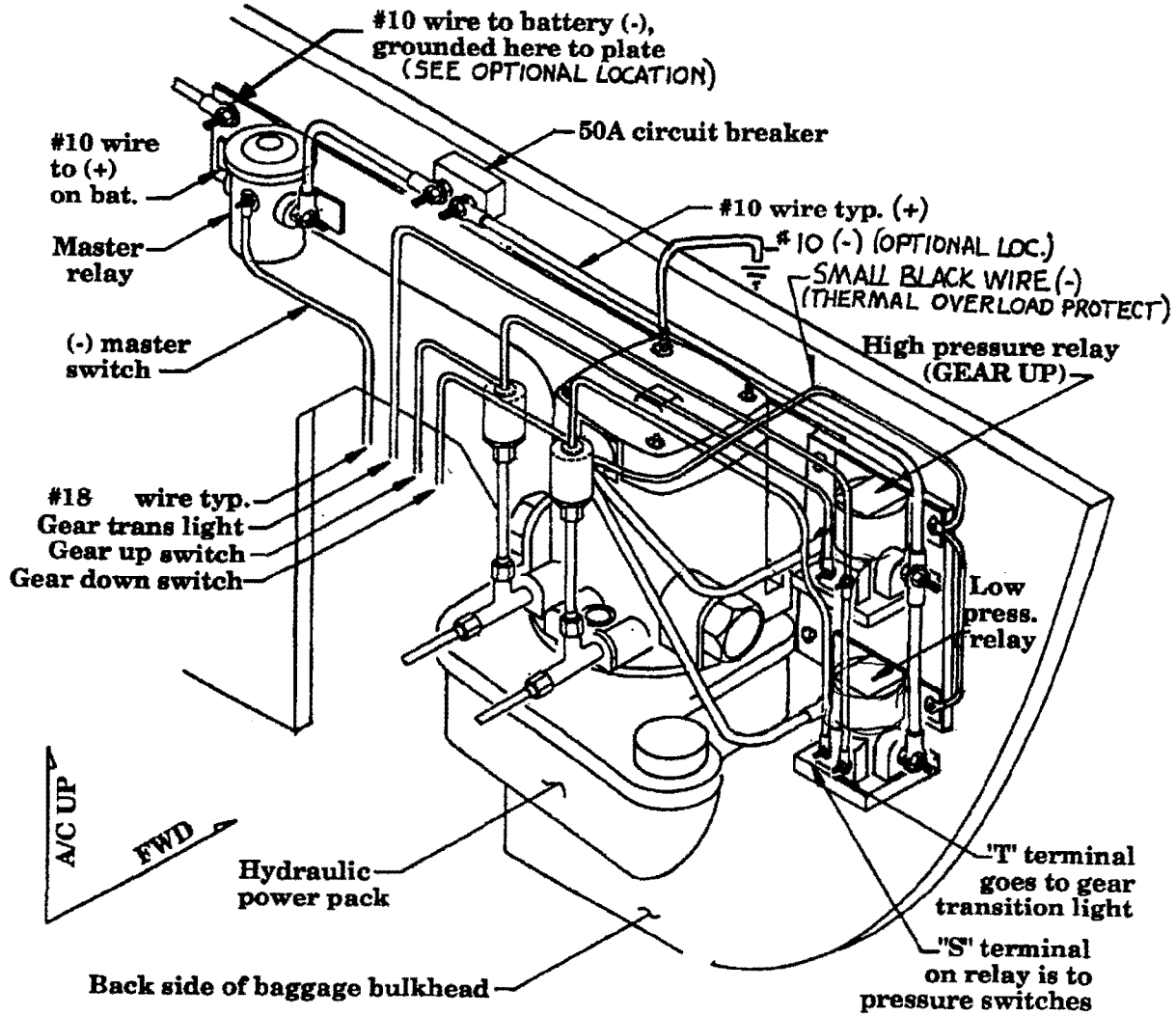

PRESSURE SWITCH ADJUSTMENT

The pressure switches will control the power to the motor relays and thus the power to the motor itself. These switches are preset but they are also easily adjustable. Without pressure they are wired in the NC (normally closed) configuration. When the pressure setting is reached, they will open thus cutting current flow.

SYMPTOM: The gear in retract mode, runs in short on and off bursts until the gear is fully retracted.

CAUSE: The pressure switch is most likely shutting off current to the relay and as backside pressure drops, the switch closes again providing current.

CURE: The UP side pressure switch will require a higher setting.

- 1) Remove the two small nuts on the back of the case and gently pull the case back to reveal the inner nuts (which are of the same size). These are the two nuts which hold spring tension on the two internal compression springs.
- 2) Turn these two nuts down approximately 1 full turn thus tightening the spring load.
- 3) Test the gear again and tighten additionally if required.

NOTE: It is possible to over tighten these nuts which would result in the inability of the motor to shut down even though the gear was fully retracted, (ie: the pressure setting would be then set higher on the pressure switch than the bypass relief valve setting within the pump.)

If this occurs, immediately cut power to the motor and loosen the two nuts in the pressure switch until proper operation is achieved.

PRESSURE SWITCH

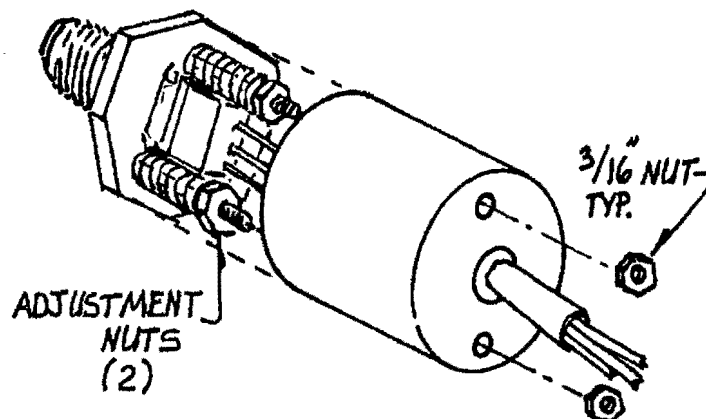

B. Gear free-fall valve installation

The Free-Fall valve must be located in a position that affords relative ease of reach. The ability of free falling the gear should be checked regularly in flight, the proper test procedure will be detailed at the end of this chapter.

1. See figure 14-5 for a method of securing the valve in position. This valve should be located at a position that can be reached with relative ease by the pilot. It is generally positioned just fwd of the instrument panel center console area and up on top of the nose gear tunnel.
2. Generally, the Free-Fall valve is desired at a position that flushes with the left side of the nose gear tunnel, to avoid interference with the pilots right leg, see figure 14-6. The valve can then be positioned behind an upholstery panel which has a hole nicely cut in it for access. This makes for a good looking finished detail.

NOTE that the Free-fall valve has the two AN912-1D reducers installed into it so that it can attach to the AN825-4D fittings spliced into the lines.

Gear Free-fall valve mount bracket & assembly

Figure 14-5

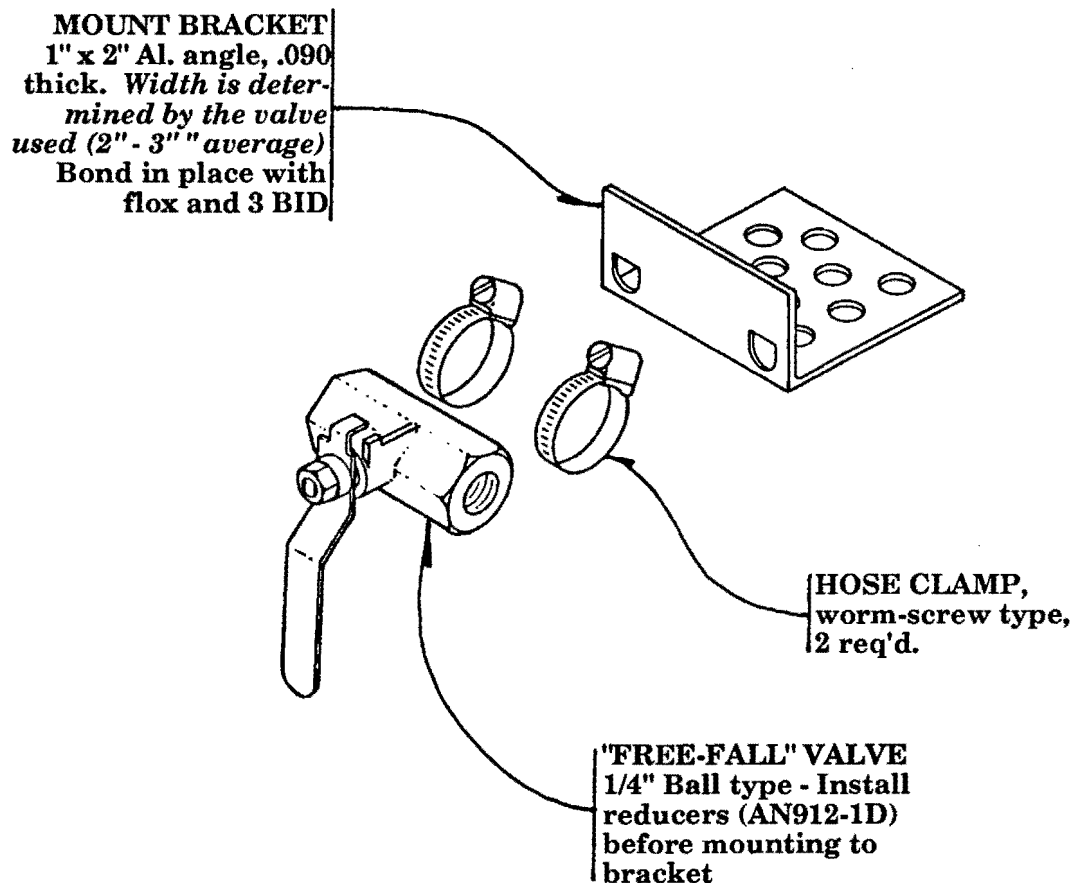

Gear Free-fall valve placement

Figure 14-6

Be sure that the valve handle has free movement, that the upholstery will not interfere, and that the valve is easily accessible by the pilot!

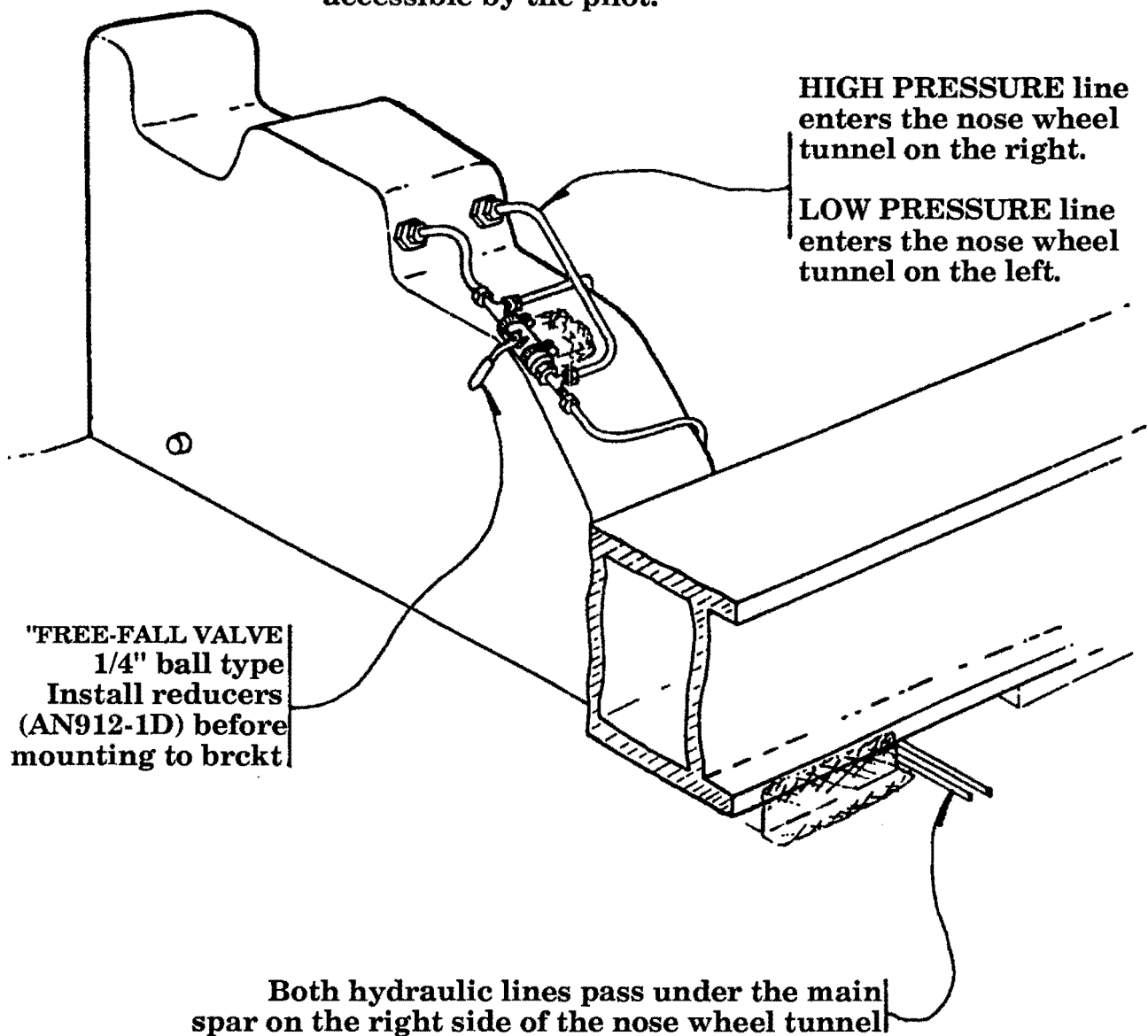

D. Flexible hydraulic line fabrication

We now use R 703 hose for all Lancair flex line applications. The fittings are two part assemblies consisting of a "socket" and a "nipple". The socket fits over the hose and the nipple threads into the socket. The end fittings can be easily installed provided you follow a couple of simple instructions. See figure 14-7.

1. When sizing the line lengths, don't forget to calculate the length of each fitting on that line. **The fittings will add 1-1/4" each to the line assemblies overall length.** Thus the flex hose itself must be cut 2-1/2" shorter than the *overall* hose assembly length to compensate for the length of the two fittings.
2. A mandrel is required. This need only be a simple steel rod of proper diameter. We use a drill bit #11) which slips through the threaded nipple portion of the fitting (it should not be a snug fit, or you may not be able to remove it once the socket is tight).
3. Make a clean cut with a sharp utility knife on the first end of the flex line.
4. Next slip the mandrel (drill bit) about 2" into the hose end (the bit should however be sticking out of the hose by 1-1/4" minimum). Place the hose into a vise, vertically, with 3/4" extending above the jaws. Then snug up the vise on the hose, not too tight, just enough to hold it firmly. You won't crush the hose since the drill bit is inside of it (something that works well here is a piece of wood with a hole drilled through it the size of the hose diameter, then sawn through the center of the hole - you can put the hose in the hole in the wood and chuck up the wood in the vise. The saw blade width now missing from the wood usually gives you just the right amount of gripping force when clamped into the vise).
5. Now use a 9/16" end wrench to screw the socket portion of the fitting onto the hose. **THESE ARE LEFT HANDED THREADS, IT WILL SCREW ON WITH WHAT WOULD BE CONSIDERED A BACKWARDS ROTATION.** Once you start threading the socket on, try to keep a steady, progressive movement going. You will be generating heat from the friction and if you stop in the middle, the going will be tougher when you resume. So don't stop until the socket is screwed fully onto the hose (.650" hose penetration). Note the small "tick" marks on the barrel of the socket, that's where the hose should screw up to. Thus with .75" of hose sticking out of the vise, you will basically continue until the socket screws just short of the vise jaws.

NOTE: You will generally have to push against the end of the socket as you twist *counter clockwise* in order to get it started on to the hose. Once the threads are engaged, you can simply twist.

6. Next remove the hose from the vise and place the socket into it (the hose). Then thread the nipple into the socket. These are standard, right hand threads. Oil threads with Hoze oil or 30 wt. motor oil. Slip the nipple over the mandrel and push as you twist to engage the threads. This nipple should be tightened up until just snug against the socket. This requires a 9/16" wrench as well. That's it except for the visual check.

WARNING: It is very important to make a visual check to verify that the nipple entered the hose correctly and did not create a blockage due to misalignment. When finished with the fitting installations, check by looking through the end of the completed hose piece. This is actually quite easy to do. Simply have a bright light at one end and sight through the other end. Pull and slowly rotate the hose until it is straight enough to see through it. You'll be able to view the opposite end fitting quite clearly. There must be absolutely no obstructions in the line. Sometimes, if the nipple mis-enters, it will cut a slice of hose lining out and push it to the end of the nipple. This could cause disastrous effects and failure at some point in time during operation. So check carefully.

Another test is to blow through the hose first from one end, then from the other, and make sure that there isn't a bit of torn hose anywhere in between acting as a one-way, or "flapper" valve. If this is the case, you may feel a different resistance or hear a different sound as you blow first from one end, then the other.



E. Aluminum hydraulic line fabrication

The Lancair uses all 1/4", 5052-0 rigid line. This requires AN818-4D nuts and AN819-4D sleeves for end fittings. The only flare angle acceptable is 37°.

WARNING: DO NOT USE AUTOMOTIVE FLARING TOOLS, THEY ARE 45° AND TOTALLY UNACCEPTABLE. FITTING FAILURE WOULD RESULT. Only aircraft type, 37° flaring tools can be used.

1. Use tubing cutter to cut the end of the aluminum tube. It should be a good, perpendicular straight cut. After that, use a flat file to dress the end of the tube so that it is squared off nicely with no ragged saw cut marks. You'll notice a slight "burr" which often results along the edges of the tube end. These burrs should be removed. You can use a pointed knife to carefully remove JUST the burr from the inside of the tube and a file to carefully remove JUST the burr from the outside perimeter. Remove only the burr and no more. Blow out the line with compressed air.
2. Now slip the nut assembly over the tube in the proper order. First the AN818-4D nut (small dia. end goes on first) and then add the AN819-4D sleeve (facing the proper direction - narrow end goes on first). *You will surely forget this more than once and be forced to cut the flared end of the tube off again since you've make the flare without first putting the nut assembly on. You can get away with that on the first end, but not on the last end.*
3. Now you're ready for the 37° flare. There are many types of flaring tools available from cheap to pretty expensive. We use a \$50.00 unit that performs very well. Single flares are acceptable. Consult your flare tool instruction book for specific instructions on use of the tool.

In general though, the flare should be just wide enough to cover the sleeve that mates to it. If the flare gets too wide, the end will start to break down and crack due to excessive stretch. This could cause a failure either right away or at some distant point in time. If your flare looks too big, don't guess about its integrity, just saw it off and make another. The aluminum line is not very expensive and leaking hydraulic systems are a real nuisance.

Hand bending aluminum hydraulic line

Figure 14-8

With your thumbs close together, bend a little then slide the tube fwd 1/8" and bend again, then slide fwd 1/8" and bend again, etc.

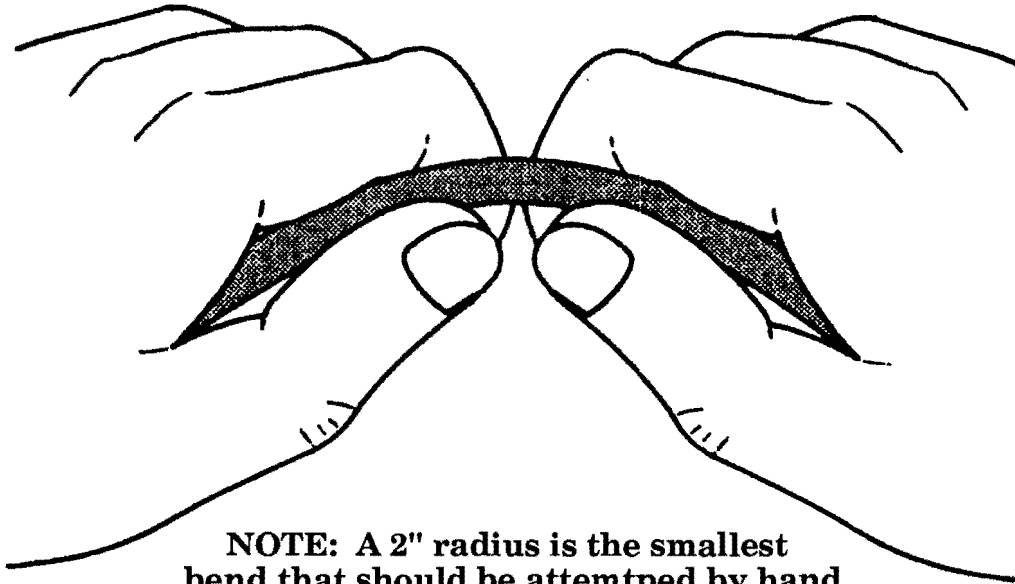

4. **Bending the aluminum hydraulic line:**
The supplied aluminum line is 5052-0 which is not particularly difficult to bend. The primary requirement is to avoid any "kinks" that would close up the inner diameter and consequently restrict the flow. There are many types of hand operated tube benders, you do not need an expensive, highly sophisticated bender. In fact, if you are very careful, you can produce excellent bends by use of just your thumb and fingers to very gently make the bend. Try to keep the radius as generous as possible with a 1" radius being about the smallest advisable. The smaller the radius, the greater care required to produce it correctly. See figure 14-8.

F. Installing the gear high and low pressure lines

With the power pack installed onto the aft face of the baggage bulkhead, the lines can be installed. We will start at the pump and work our way forward.

This is a very straight forward installation and is very simple. The primary initial concern is to be very certain NOT to mix up the high pressure vs. low pressure lines. And that's easier to mix up than you might expect. It's even a good idea to mark the ends of the lines with colored tape as you go - green for down (low pressure lines) and red for up (high pressure lines).

It is generally best to first attach all the aluminum lines, then come back and attach all the flexible lines. This keeps you working with the same sets of tools instead of jumping back and forth and getting slowed down in the process.

1. From the power pack, two aluminum lines will be routed forward. One will be for high pressure, one for low pressure. Review figures 14-1 and 14-2 thoroughly before proceeding. Note that two installations are shown, the system used with the optional hydraulic main gear door closure (figure 14-2) will obviously have additional lines for them. You should have made up your mind about this option before continuing (the hydraulic gear door option is however, retrofitable at any time, it's just less work if you figure it out now).
2. Locate the position on the cockpit floor where the AN827-4D "Cross" fittings will be installed. There must be adequate clearances around these fittings so that the lines can be easily routed to them without rubbing on anything.
3. Use a measuring tape or a piece of string to trace out the length of these first lines (from power pack to "Cross" fittings). Refer to figure 14-1 for orientation. You will likely be installing and removing these lines several times each before the "final" installation. This first sizing is only to get the piece of tubing cut to approximate size (remember that it can be a little long, but it cannot be a little short!).
4. It is generally best to measure the approximate tube lengths *between* bends and make those bends prior to inserting the tube into the fuselage. These first two tubes will extend under the aft spar and should be kept well to the sides of the center "tunnel area thus clearing the elevator push rod and idler arm assembly which should be already installed behind the aft spar.
5. When the fit is close, attach the ends of these first tubes to the power pack as shown in figure 14-1. Finger tight is OK for now. Now it will be easy to locate the exact trim point for the other end of the lines so as to attach nicely to the "Cross" fittings.



6. Check the tubing's overall alignment, adjust as necessary and attach the other ends to the "Cross" fittings. These lines can lay loose on the floor for now. Later, the lines should be anchored at periodic points to secure. See figure 14-9 for a suitable means of securing lines to stationary objects (like fslg floor, nose gear tunnel sides, etc.).

Once all the lines are positioned, both rigid and flexible, the assembly will begin to nearly hold itself in position by virtue of their rigidity once attached to bulkhead fittings, etc. However, these lines should still be anchored at a few points which are shown in figure 14-1 (or 14-2).

ANCHOR POINTS for ALUMINUM HYDRAULIC LINE

Figure 14-9

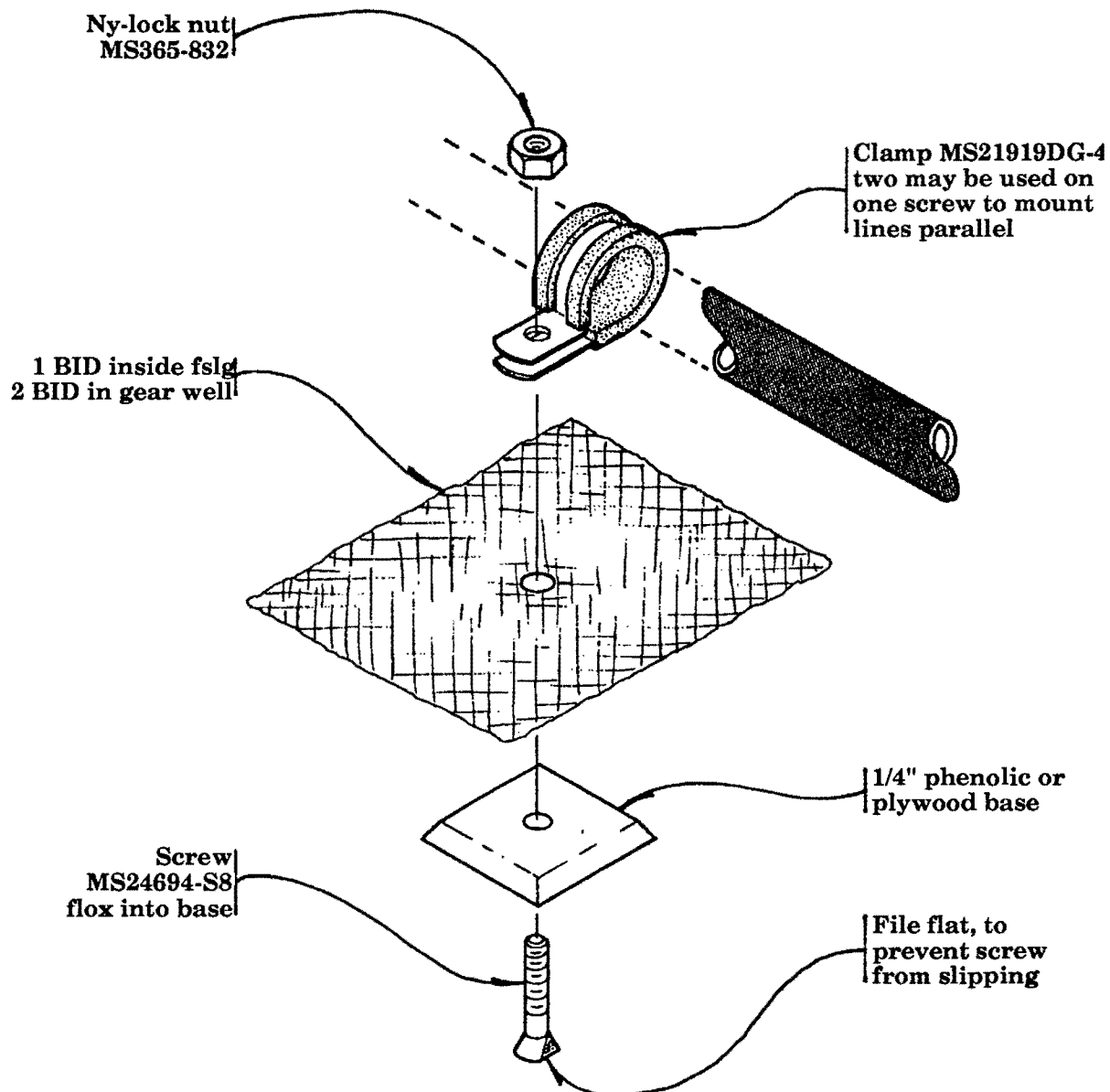

7. Install the bulkhead fittings, that attach to the cockpit closeout ribs, from gear well side of the rib. Use a 7/16" drill bit to drill through the area that has the core material removed and reinforced with 3 BID from the inside. Refer to blueprint "K" for these bulkhead fitting locations, and see figure 14-10. These will be the next connection points for line installations.

NOTE: If you drill a good clean hole for the bulkhead fittings, the fittings will seat nicely into the hole. If the hole is a little ragged then the small end of the bulkhead fitting will not seat properly since its shoulder is only 0.065" wide. If this should occur, simply slip an AN960-716 washer over the fitting first, then insert it into the hole and tighten up with the AN924-4D bulkhead nut.

Note that there are three bulkhead fittings for each side when using the optional hydraulic gear door closure system. For the mechanical system, there will only be two fittings installed per side and the AN804-4D fitting will have an AN926-4D cap attached to seal off that extra unused port.

Bulkhead fitting installation for hydraulic lines

Figure 14-10

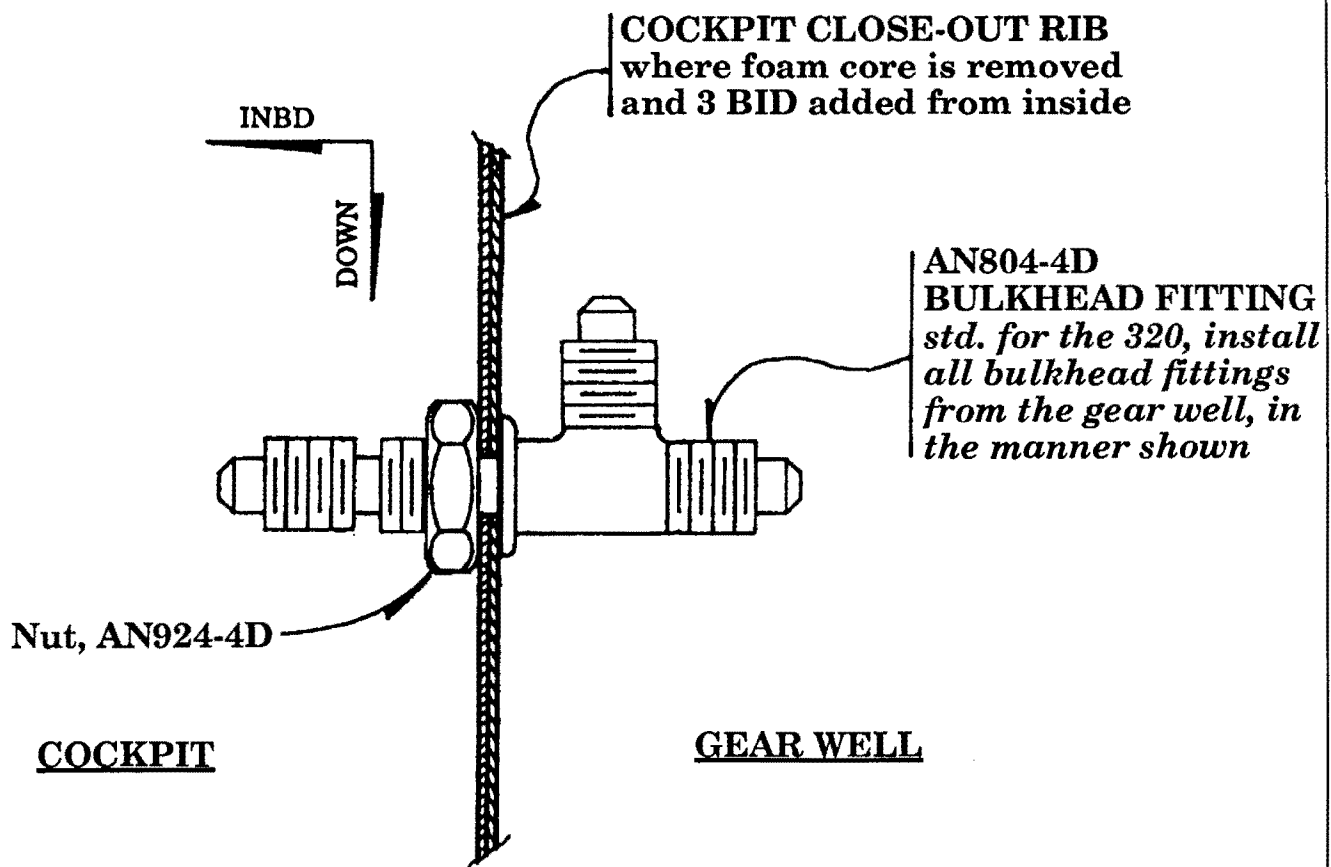

8. Make and attach the lines that run from the "Crosses" to the AN804-4D fittings next. See figure 14-2. If you have the standard mechanical gear door (figure 14-1), then route the low pressure lines from the bulkhead fitting to the low pressure "Cross" fitting next.
9. Next continue the aluminum lines forward, under the main spar to the position just aft of the nose gear tunnel where the Free-fall valve is located. See figure 14-6. The Free-fall valve will have the two AN912-1D reducers installed onto it so that it can attach to the AN825-4D fittings spliced into the lines.
10. Next you will install the bulkhead fittings into the nose gear tunnel. Before drilling the holes, retract the gear by hand and verify that you will have adequate clearances for the fittings. See figure 14-6 for location. Drill the 7/16" holes and install the bulkhead fittings in the same manner used for the close out rib, refer to figure 14-10.
11. Install the lines from the Free-fall valve to the above bulkhead fittings on the nose gear tunnel.
12. This will complete all the aluminum line installation inside of the fslg. The aluminum lines still must be installed into the nose gear well from below (one line to the sequence valve). If you have the optional hydraulic gear door system for the main gear, then there are two additional aluminum lines in the main gear wells yet to install.
13. For the optional hydraulic main gear doors, refer to blueprint "K". Before you can install these two lines, the sequence valve must be located. During line installation, check by cycling the gear up by hand, that proper clearance is maintained from all moving parts. The two aluminum lines should route up high into the "fillet" area formed where the upper skin rolls up and meets the fslg. See figure 14-11. These lines will route through the partial rib in the stub wing, use either a short length of rubber type hose as an insulator or use grommets. You can simply drill through the partial rib and install the lines. No reinforcement is required. Anchor the lines in the gear well since air turbulence is one added factor in the gear wells. See figure 14-9 for recommendations.
14. Install the one and only aluminum line into the nose gear tunnel, see figure 14-12. This line runs from the AN834-4D bulkhead "T" to the "IN" port of the sequence valve. This line must also be secured and carefully clearanced away from all moving parts in the nose gear well.

THIS WILL COMPLETE ALL ALUMINUM LINE INSTALLATIONS

STUB WING INSTALLATION OF HYDRAULIC LINES

Figure 14-11

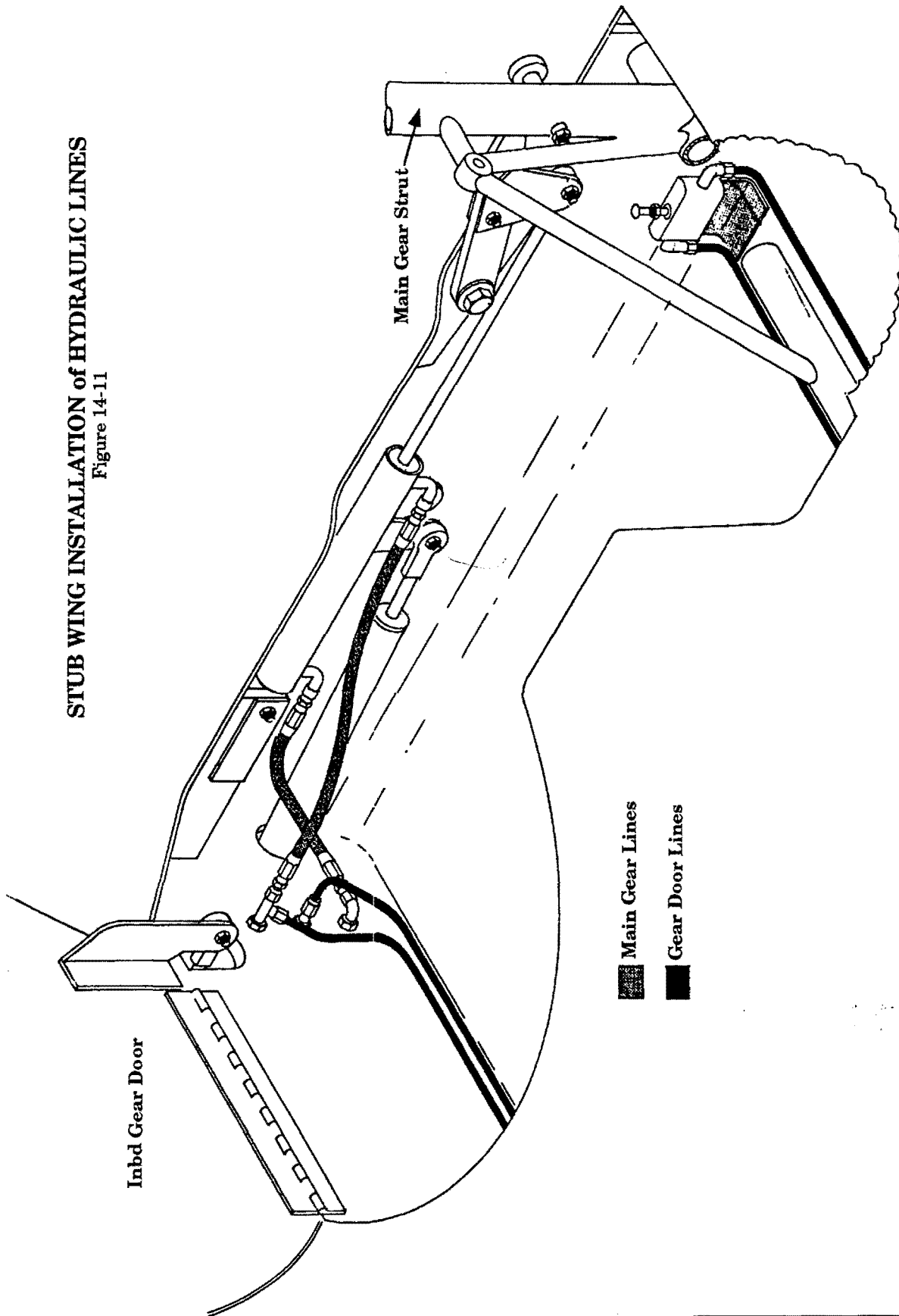

Hydraulic line routing inside the nose wheel tunnel

Figure 14-12

LOW PRESSURE- Bulkhead fitting may be either a AN833-4D or AN837-4D (optional- use a AN804-4D "T" bulkhead fitting & install a flex hose to the open, low pressure end of the gear door cylinder.

HIGH PRESSURE- Bulkhead "T" fitting may be either a AN834-4D or AN804-4D.

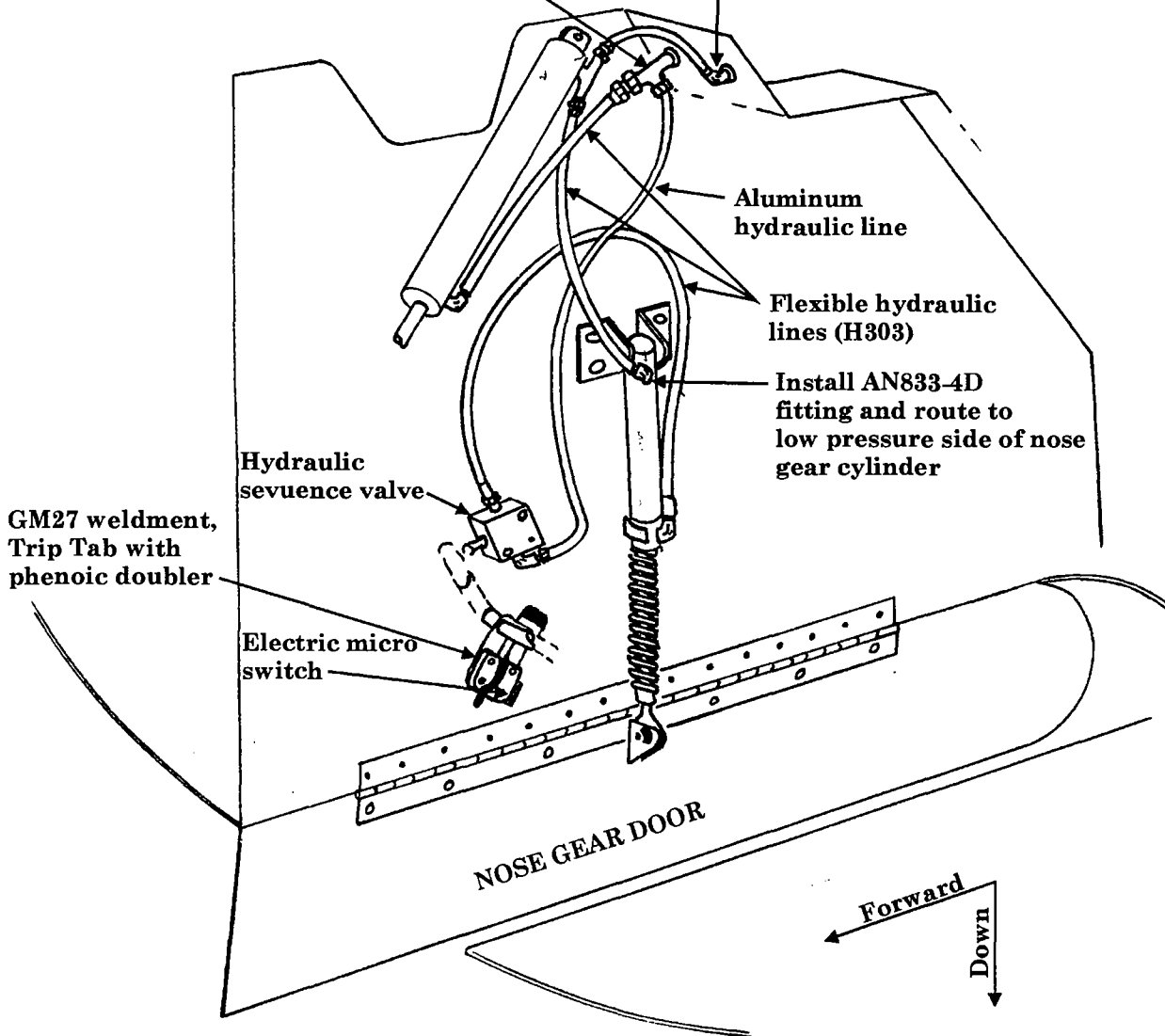

G. Flexible line installations

With the aluminum lines all installed, it is a relatively easy matter to install the hydraulic flexible lines.

1. Start in the main gear wells and fit the high pressure lines (for gear retraction) first. See figures 14-1 and 14-11.
2. Next fit and install the low pressure lines to the main gear cylinders (for gear down). These lines are a bit more critical in installation since their length must be just right to not kink or be stretched.
3. Cycle the gear up and down by hand to verify the installation and clearances. These lines must be kept away from all moving parts that could generate a "rub". Also check that they clear the tire as it passes by during retraction. The nylon type wire ties work very well for securing the flex lines.
4. Next fit and install the three flex lines in the nose gear tunnel. See figure 14-12.. These lines must, like all the others, be verified as clearing all moving parts. When the assembly is completed, run the nose gear up by hand and verify clearances.
This will complete the flexible line installations and thus completes all gear hydraulic line installations.



Gear electrical installations:

The gear electrical installations, although described in this chapter, should not be made until basically all glass work is completed on the airframe. The one exception is regarding the power pack assembly with pressure switches and relays. This assembly can be wired at most any time.

H. Gear switch

1. The standard gear switch is a locking switch, as shown in figure 14-13. It takes up little room on the instrument panel. The switch is a SPDT meaning that it "pulls" voltage from a single source and can "throw" that voltage in either of two directions. The switch is in addition positive locking and must be gently pulled out of its detents before it can be shifted to the opposite position. As with all electrical parts, it should be handled with care and kept clean.
2. The center contact of the gear switch will have the primary "hot" lead from the battery soldered to it. The other two contacts will connect to either of the pressure switches. The wire on the pressure switch that connects to the gear switch can be either the red or the blue lead (the white lead is not used at all). See figure 14-13, and refer back to chapter 5, pages 5-59 and 5-60.

NOTE: It should be pointed out that the alignment between gear switch handle position and the back contacts is perhaps opposite to what you might think is correct, i.e., if the gear switch handle is "UP" then the contact on the "bottom" is activated, and vice versa. This will obviously become important when you wire it. See figure 14-14 for a suggested location of the gear "quadrant".

Wiring - landing gear switch

Figure 14-13

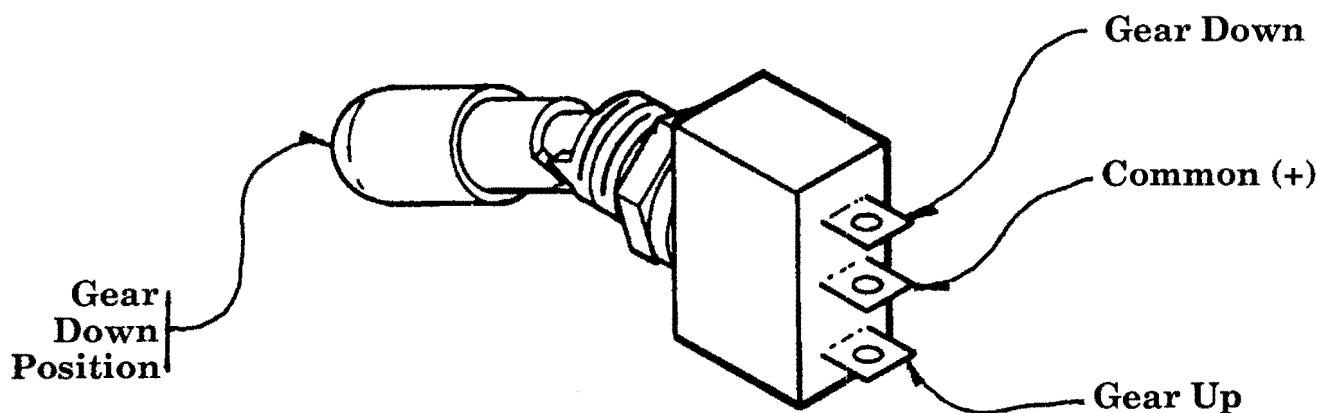

Gear "quadrant" location
Figure 14-14

Std. indicator lights shown, optional dim-adjustable lights are available from Neico

Or locate
GEAR QUADANT
here

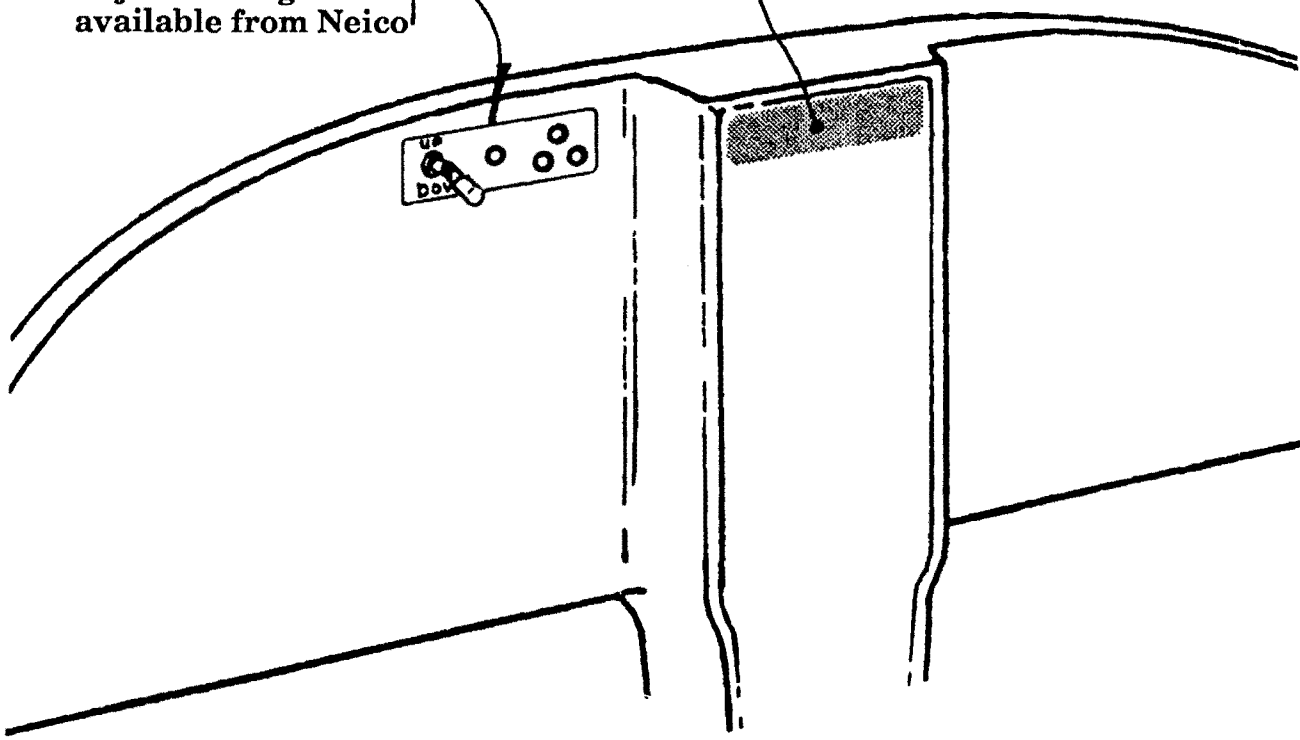

I. Gear down lights

The standard gear lights are AMP type lights and are non-dimmable. For night flight, you will want to install an adjustable "pot" to be able to dim the lights at night. Optional gear lights with push to test and dim features are now available from Neico.

1. These lights will be illuminated by voltage that is interrupted by the gear micro switches. Thus the micro switches must be "CLOSED" in order for voltage to pass by and reach the gear lights. This "closed" position is only achieved when the gear is down and locked. See figure 14-16 and the wiring diagram, figure 14-17. Generally, the gear down (green) lights are arranged visually so that the center green light is for the nose gear and the left is for the left main, etc.



J. Gear transition light

A gear "transition" light (amber or yellow) is provided. This light allows you to monitor exactly when and how long the gear motor runs. It is an excellent safety feature in that it can indicate problems that you might not otherwise be aware of.

Example: If you have a small hydraulic leak, the gear transition light will warn you of the condition since you will see this transition light blinking on and off repeatedly during cruise. This will alert you to start looking for leaks as soon as you next land. That's much better than running the system out of fluid unexpectedly. Also, if for any reason the pump motor does not shut off within 20-30 seconds, you will be alerted and you should then immediately pull the relay breaker on the instrument panel to shut down the system. Otherwise you would run the risk of burning up the pump motor.

The gear transition light is generally placed just to the left of the three green gear down lights, near the gear switch. These units together comprise the "gear quadrant".



K. Gear micro switches - main gear

Gear micro switch installation & adjustments

Each of the landing gear will require a micro switch to indicate a "down and locked" condition. This is a simple installation but extreme care should be taken with the micro switches themselves and with the wiring that connects them. If a wire were to fall off because, for example, you did not adequately secure the wires on the gear bay, the net result would be some very high anxiety when you realized that the gear down light was not on. Of course in that case, the landing would be uneventful but there is no point in stressing your anxiety levels due to loose wires or improperly adjusted micro switches.

1. The main gear micro switches will attach to predrilled holes in the GM4 alignment brackets. These are the small (4-40 screw size) hole and slot in the inboard ends of these GM4 brackets.
2. First simply place the micro switch in relative position and check to see if the chrome trigger arm requires any trimming. Some may require trimming for clearance from the welded boss on the GM4. If so, snip with a pair of wire snips. The trigger arm must fully clear the GM4 boss.
3. Position the micro switch and insert the inboard 4-40 screw with AN365-440 lock nut. See figure 14-15.

WARNING: Do not overtighten the micro switch mounting screws. They should be snug only. Overtightening could cause the switch case to crack. If the case becomes cracked, the switch should be discarded and replaced.

4. The outboard micro switch mounting screw will fit into a slot in the GM4, thus allowing adjustment range. Insert this screw and tighten it up just a little so as to still allow hand rotational adjustment of the switch, i.e., it should have a little friction but still be movable.
5. With the gear in the fully adjusted, down and locked position, rotate the micro switch until it strikes the roll pin that extends out of the forward face of the GM3 (over center link assembly). When you hear the switch "click" then the contact will be made. You'll notice that you will still have additional rotational adjustment remaining. Some of this additional depression of the trigger is advisable. The proper adjustment is achieved when nearly all of the available trigger movement is taken up but the trigger should not be tightly "jammed" against the switch case. There should be about 0.010" clearance remaining.
6. When the micro switch is adjusted correctly, then very carefully snug down the two 4-40 screws and nuts that secure the switch to the GM4. Check with your fingers that you can no longer move the micro switch by hand.



Micro switch installation, main gear
Figure 14-15

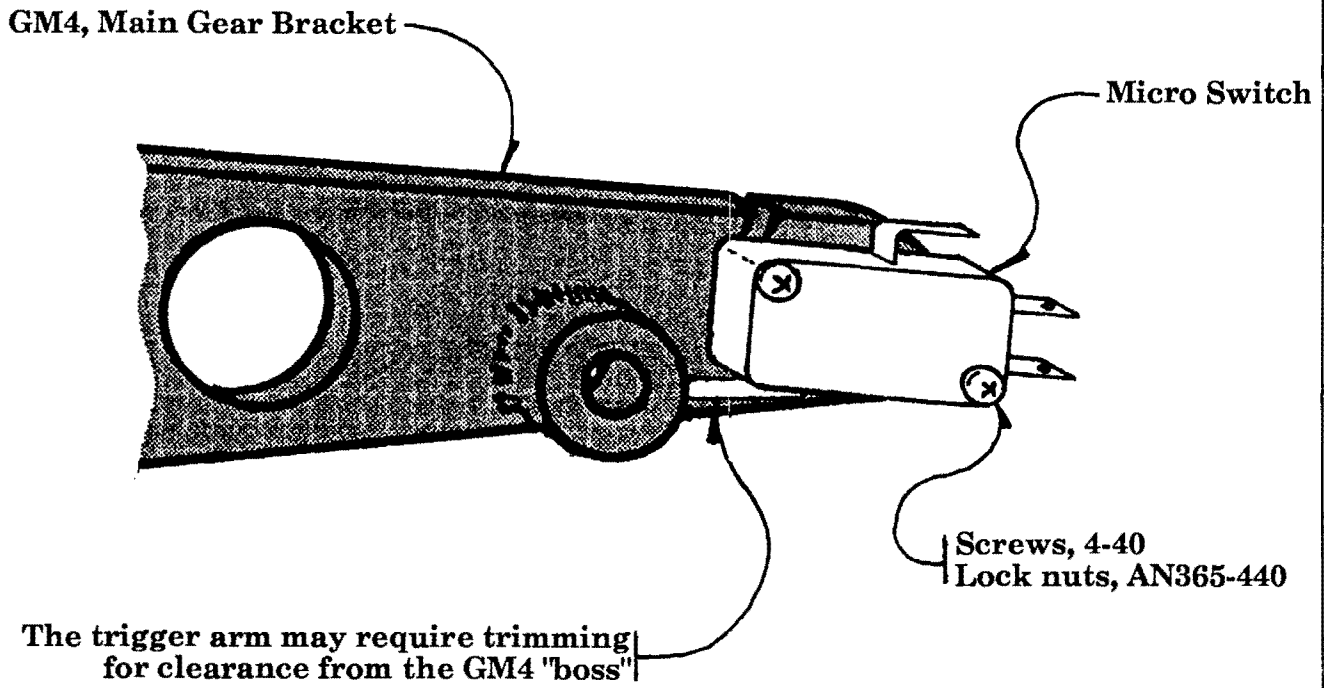

L. Nose gear micro switch

The nose gear micro switch is a different type of installation. Refer to pages 5-47 to 5-50, "nose gear gas strut installation", and to figure 13-5, "Positioning the nose gear sequence valve & micro switch). This assembly should be adjusted in a similar manner as that used with the main gear micro switches. The switch will be rigidly mounted to the aluminum attach plate and all adjustments will be made by positioning of that created assembly as it rotates on the two MS24694-S8 screws.



M. Gear micro switch wiring

The wiring for the micro switches is quite simple. The stock switches are built such that they can be used as NO (normally open) or NC (normally closed). We will only use the NO (normally open) circuit and thus one spade connector will not be used on the switch. If you look closely you will see the markings on the switch case, see figure 14-16. These are 3/16" wide spade terminals as are the terminals on the gear lights.

Micro switch wiring connections

Figure 14-16

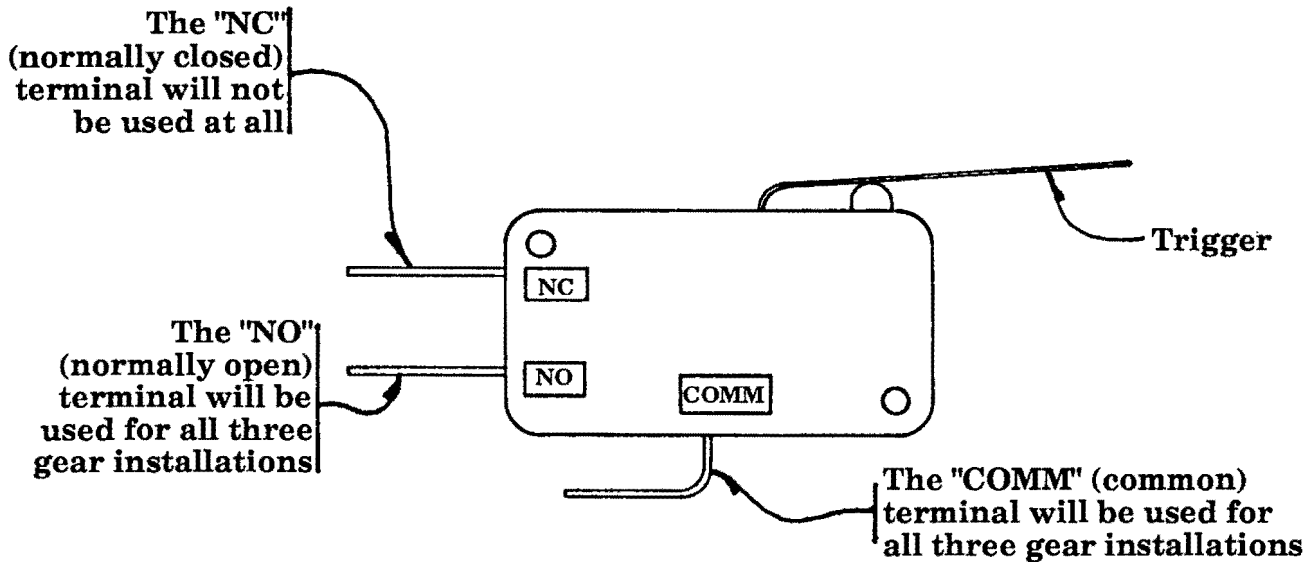

1. The micro switch wires should be tied securely in the gear wells since considerable air turbulence will be encountered. Use the nylon type wire ties. Also, it is important to use the insulated type of terminal connectors to prevent water, etc., from making a contact and giving a false reading.
2. We generally use the (-) side of the electrical system to route through the micro switches and wire the (+) side directly to the gear lights. See chapter 18.
The wiring can be 18 or 22 gauge. Two wires are needed for each micro switch which must be routed to the back central area of the instrument panel. This wiring can enter the cockpit area through the cockpit closeout rib. A good location is between the spar closeout web and the aft phenolic attachment for the retract cylinder. See figure 14-11.
3. From there, route under the main spar (at the central console area) and up behind the instrument panel. The nose gear switch wiring can simply travel up the side of the tunnel and punch through the radius where the side of the tunnel rolls into the top portion. See figure 14-12.



N. Gear pressure switch wiring

1. This is again very simple. Refer to page 5-50. There are two spades exiting the pressure switches.
2. The high pressure switch which operates the "gear up" cycling is located above the left port on the power pack. One wire on that switch will connect to the relay that operates the pump (high pressure side). The other wire on the pressure switch will connect directly to the lower solder terminal on the gear switch (remember that the lower terminal makes electrical contact when the switch handle is up).
3. The low pressure switch will connect in a similar manner to its respective contacts.
 Also see section "P" of this chapter for possible adjustments of the pressure switches.



0. Gear wiring schematic

1. See figure 14-17. This is a very straight forward schematic and should be easy to follow. As mentioned already, the 50A circuit breaker is generally located on the face of the baggage bulkhead. This will save weight and make for a nice compact installation.
2. The gear pump will draw about 30-40 amps and therefore must run through the two relays. This pump motor will spin in both directions thus generating a gear up and gear down movement of the hydraulic fluid.
3. Note that the secondary terminals on the relays will be jumped together and will operate the "Gear Transition Light".
4. From the power pack itself, you will have to run three wires up to the instrument panel. One for the gear up relay to the gear switch, one from the gear down relay to the gear switch, and one from the relays to the "Gear Transition Light".

Note: Differences Between Old and New Style 235/320/360 Landing Electro/
Hydraulic Power Packs.

Old power pack for all 235's and many 320/360's
Motor has 3 wires
Large blue and green
Small black

New current power pack
Motor has 3 wires
Large blue, green, and black

Note: The old power pack has an internal temperature sensitive switch which is normally closed at lower motor temperatures, and opens when the motor overheats. The small black wire is connected to this thermo switch and opens along with the switch. When wiring this unit, the blue and green wires are connected to the high (up) and low (down) solenoids, respectively. The black wire is used to provide the only ground for the solenoids. If the motor overheats, the black wire opens, the solenoids lose their ground and they open, which stops the power pack motor. The motor ground is connected to the motor housing with a separate wire.

Old Style Schematic

Landing gear system

Figure 14-17

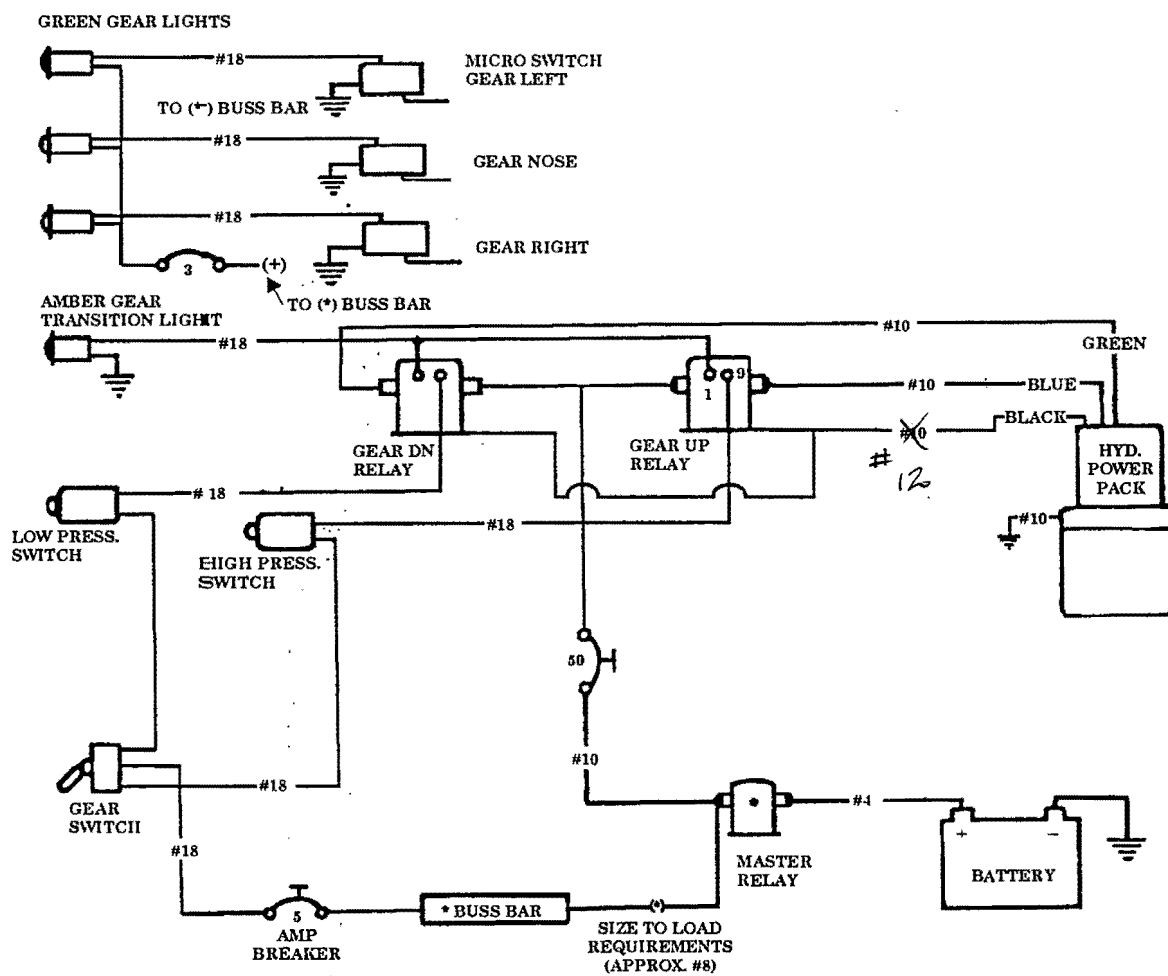

Lancair International Inc. Copyright © 1997, Redmond, OR 97756

Note: The new power pack has an internal load and temperature switch which stops the motor when either condition goes over the limit. The black wire is used for the motor ground.

New Style Schematic Landing Gear System Figure 14-17A

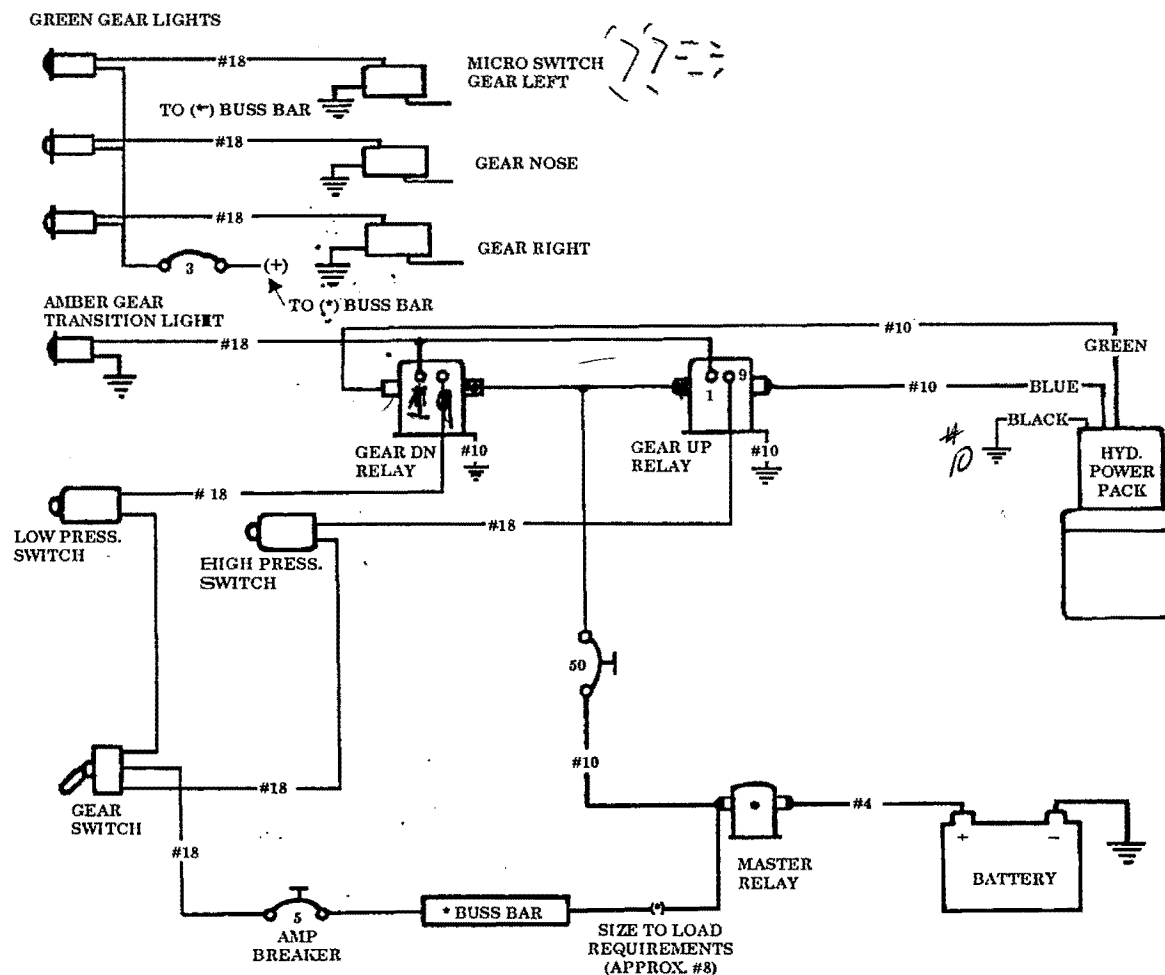

P. Gear system start up / test operations: Adding hydraulic fluid

Fluid type: Petroleum based
MIL-H-5606-Red

You'll need about 1 qt. minimum therefore you should get 2 qts.
This fluid is the same as used for the brake system.

1. Remove the filler cap and fill with fluid. A piece of 1/4" vinyl tubing works well as a siphon tube from a 1 qt can of fluid. Pinch off the tube when the reservoir is full.

NOTE: Before starting the system up for the first time, go around and check each and every fitting to insure that it is tight. The odds are very high that no matter how many times you "thought" you checked that fitting, it will still be loose and that will cause a mess. Also, have many rags around and have a very quiet room when you first start up. A quiet room will allow you to hear the "fissss" of a leaky fitting that's under pressure.

2. The reservoir will hold about a pint of fluid which will be emptied as the gear is first run and the empty lines are filled. This will then require refilling of the reservoir. The reservoir will usually require about three or even four fillings until all is working well and the reservoir is again full.

NOTE: The gear system will self bleed but this will take many back and forth cycles which is OK but time consuming so don't expect the cycle time to be particularly fast in the beginning. You will encounter many small "burps" of the pump motor once the gear is fully retracted because the air in the lines is compressing and the motor therefore comes on for only an instant to re-establish the operating pressures dictated by the pressure switches.



Q. Start up of hydraulic gear

When the gear is all installed, and known to operate by hand without any binds or interferences, and the pump is filled ... its time for the real thing. This, for most builders, is considered to be a monumental event and a major milestone. There is great joy in watching all that gear tuck up into the airframe and totally disappear - all by itself. Of course the odds are about 25% that you'll have some sort of a small problem to correct before it all tucks away neatly but in a short time all will be working well and the excitement of the event will still be real.

1. The airframe will have to be supported for this testing and there are two good ways to do that. One is to simply use the jack pads for the main gear if you put them into the fslg. Jack the airframe up only enough to clear the main tires off the ground and then weight the tail down or pull it down so as to lift the nose gear off the ground. The other means is to simply use a portable jack and lift the engine by the normal engine hook that temporarily bolts to the upper case bolts of the engine and slide a rigid support under the fwd baggage area of the fslg. The fslg is strong enough to be supported from such a point. (Don't ever try that with a sheet metal plane though.) We've used a small stool with a good thick foam pad on it to disperse the loads over an area of about 1 sq. ft. You'll then have to steady the wing tips. Which ever approach you use to elevate the airframe, check to verify that it is indeed stable before retracting the gear.

WARNING: Don't ever assume that you have wired everything correctly prior to this first start up. You must assume that you have wired everything **WRONG** and that the gear switch, although placed in a down position, might actually cycle the gear up as soon as power is put through it. Thus don't put power to the system until the plane is supported and can thus tolerate those kinds of surprises!

2. If you prefer, with the help of a friend, undo a line as far down stream as possible. Place a piece of hose on the line and place the other end in a clean container. One guy watches the hose while the other works the gear and master switch. Bump the system on and off until fluid and no air is coming out of the hose. Reconnect the hydraulic hose or aluminum line. Do this in a couple of locations and your system will take fewer cycles to come on line.



3. Install a battery temporarily into the system and establish the following:
 - a. Plane supported off the ground, steady and secure.
 - b. Gear switch is in the down position.
 - c. Gear itself is down and locked.
 - d. Free-fall valve is closed.
 - e. Nose gear is straight.
 - f. Cycle each gear leg up by hand to verify that there are no obstructions or interferences, etc.

Now connect the power (12V DC)

The motor will produce a good deal of noise and will run for several seconds beyond the normal 6-7 seconds for cycling since there is no fluid in the lines at this time.

WARNING: The motor must not be allowed to run more than 20 seconds continuously. Running beyond that length of time could generate too much heat and damage the motor.

4. If the motor runs more than the 20 seconds allowed, remove the power thus shutting the motor off. The motor is not designed for continuous operation and must be allowed to cool down somewhat before operation can continue. Give it just a few minutes (5 min. should be sufficient) to cool down before continuing.
5. Check all fittings for leaks and correct as required.
6. Check the reservoir to see if all the fluid has been pumped out, refill and continue to pump in the down direction. If three runnings like this do not shut the pump off automatically then stop and continue with the next step. Thus don't worry about it for the moment.
7. Check again that the nose gear is straight.
8. Flip the gear switch to the up position and observe as it starts to retract. The order of retraction is unimportant as that is strictly a function of which system gets the fluid first.



9. As the gear retracts, generally the mains will retract first and the nose will follow last. Once all the gear is up, assuming it all goes up on the first try here, the motor should run for just two or three seconds only and automatically shut down.

WARNING: If the motor has adequate amounts of fluid available, you will hear a distinctive tone change as the pump reaches its higher PSI loads. It will slow down and sound as if it is working harder. This is when the heat can really build up fast in the motor as it can pull over 40 amps so do not let it run more than two or three seconds in this condition.

10. If the gear comes up and the motor bogs down without shutting down automatically, then the pressure switch will require adjustment. This rarely will happen though.

If the gear comes up most of the way and the motor continues to run with little or no tone change, then you are again out of fluid in the reservoir. Shut the system down, free-fall the gear down and locked and crawl back in to refill the reservoir.

11. Cycling the gear up and down several times will work to bleed the air out of the system and you'll notice that the cycle times will become shorter. Once the system is fully charged and free of air, the cycle time should be about 7 seconds.

12. When the gear retracts, the motor will shut off due to the pressure switch being tripped which cuts the current to the "UP" relay. If, as mentioned in step 9, the pump does not shut off automatically, then the pressure switch will need adjusting (or you've got a basic wiring problem that's having the effect of bypassing the high pressure switch). See wiring diagram and the section following this one, "Pressure switch adjustment".

NOTE: As the nose gear retracts into the well, if it is allowed to hit the GM27 weldment, a pretty loud "clunk" may result. This should be avoided by attaching a rubber strip around the weldment to serve as a cushion. A couple of nylon wire ties will adequately secure it in place.

13. It is common for the motor to cycle on for a couple of periodic "burps" when the gear retracts. This is the system "tightening" up on itself as air is compressed and slowly forced out of the loop as cycling continues.

If you get repeated, continuous bursts of the pump motor, then there is a leak some place so shut it down and go hunting.

14. At some point it is a good idea to run the gear up with some of the gear doors removed so that you can inspect the condition of everything up in the wells. Look for any interferences, binds or rubs. These must be corrected immediately. Verify that the retract cylinders are indeed bottomed out on themselves, this is critical. Make any adjustments necessary.





R. Pressure switch adjustment

1. The two pressure switches control the power to the pump motor through the relays and thus the power to the motor itself. These switches are preset but they are also easily adjustable. They are wired in the NC (normally closed) configuration. When the pressure setting is reached, they will open thus cutting current flow to the motor, opening the relay and shutting the system down.

Sometimes the pressure switches will require a little adjustment to achieve proper operation of the gear system. Here are two possible problems:

2. **SYMPTOM 1:** The gear in the retract mode runs in short, on and off bursts until the gear is fully retracted.

CAUSE 1: The high pressure switch is most likely prematurely shutting off current to the relay and as the backside pressure drops, the switch closes again thus providing current.

CURE 1: The UP side pressure switch will require a higher setting.

a. There is small slotted screw in the top of the pressure switch. Turn this screw 1/4 turn to the right. Turning to the right increases pressure and to the left decreases pressure.

b. Test the gear again and tighten additionally if required.

3. **SYMPTOM 2:** The gear retracts up but the motor does not shut off at all, it merely bogs down and continues running (As previously mentioned, this is dangerous to the life of the motor and should therefore be disconnected immediately if this symptom occurs.

CAUSE 2: The high pressure switch is set too high and although the power pack has reached full pressure, the motor can not shut off since the pressure switch has not reached its higher pressure setting. **NOTE:** The power pack has internal bypass valves that are factory set. The pressure switch must be set lower than the internal bypass valve setting.

CURE 2: Lower the pressure of the high pressure switch, see "cure 1" above. The procedure is similar except you will be backing off the internal screw 1/4 turn at a time.

4. It is also possible that similar circumstances could occur involving the low pressure side of the system. History has however indicated that usually no problem is found or if there is a problem, it will be with the high pressure system.



S. Free-Fall test

The ability for the gear to successfully free fall to the down and locked position is critical. Flight can not be made if this condition is not achievable. In addition, you should make it a practice to check it on a regular basis (monthly) during operation so you will not be caught off-guard by a broken spring or deflated pressure strut.

1. While still in your ground testing setup, run the gear up and disconnect the power.
2. Open the free-fall valve by making the 90° rotation of the handle in one smooth, quick movement.
A bit of "clang" will result and the gear will start coming down. The nose gear will usually be the first down and locked due to the 100 lb gas spring up front.
3. The main gear will usually fall about half way very quickly and the remaining half could be a slow struggle for the springs. This is OK. In fact it is OK if they never do lock down by themselves but you must measure the pressure against the sides of the tires that is required to bring them down and locked.
4. If the main gear does not lock down, take a scale and press against the inside of the tire bottoms. The force required to lock the gear down should not exceed about 5-8 lbs. This force is easily achieved by simply kicking a little rudder left to create a side slip which will lock the left main then right rudder to lock the right main. If more force is required, then you have a "bind" condition somewhere in the linkage or the springs are stretched out of shape. You'll have to correct the condition before flight.

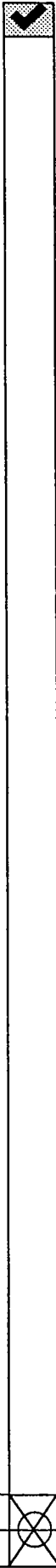

T. In-flight free fall testing

This must be conducted on a regular basis to insure safety on the event of either a hydraulic loss or an electrical loss.

CAUTION: This Free-fall check should be made monthly during normal operations. It's easy and only takes a couple of quick steps.

1. Start with the A/C in a normal gear up, cruise mode at a speed of 140 m.p.h. or less.
2. Pull the circuit breaker (or fuse) that operates the gear relays.

WARNING: Do not pull *only* the 50A gear pump circuit breaker, this would appropriately disconnect the pump but it would not disconnect the relays. This would then allow the relays, which are for intermittent use *only*, to close. Possible damage could result to the relays if left on for too long. Thus you should pull the circuit breaker *for the relays* when shutting down for this test.

3. With the electrical system disconnected, place the gear switch into the down position. Of course, nothing will happen.

4. Open the Free-fall valve with a fast smooth 90° rotational movement.

The gear will now drop down and lock in place, the three green gear down lights should illuminate. There is no particular locking sequence between the three gear. Sometimes the nose will lock first and we've seen cases where the nose gear is last to lock down. And you ask, "what if they don't lock down?"

If the main gear does not lock down: If, after one minute, the mains do not lock down (no green light appears) then try kicking in a little rudder to cause a slip in the direction of the non-locking gear leg, i.e., left rudder to lock the left main, etc. This additional air load on the gear door and gear itself, will provide the extra force to cause the gear to lock. The main gear should easily lock down with no more than half rudder applied at 140 m.p.h. indicated. If this is not successful, then you have a problem of either too much friction or too little spring pull. Ground adjustments must be made before your next flight.

If the nose gear does not lock down: If the nose gear does not lock down, first try slowing up to reduce the air loads acting against the gas strut that is trying to push the gear out into the air stream. Slow up by 10 m.p.h. increments, wait at least 1 minute between speed changes and note the speed at which the nose gear does lock down, keep this for reference to determine whether or not the nose gear is requiring more and more help as the flight hours build.



If at 85 m.p.h. indicated, you still can not lock the nose gear down, then you have a problem, do not go slower in attempting to lock it down. Increase speed back to about 110 m.p.h. and try pulling about 2 g's. If after two or three attempts at this, you still can not lock the nose gear down, then you have a problem and ground adjustments must be made before your next flight.

5. With the test completed, either all the gear will be down and locked or the stubborn ones will not be locked down. At this point, there is a three step procedure to follow when reactivating the hydraulic power system.

1. Close the Free-fall valve by rotating it 90° back to the closed position.
2. Check to make sure the gear switch is still in the "down" position.
3. Push in the *gear relay* circuit breaker to reactivate power to the pump. The gear will now recharge and establish a down and locked position under hydraulic pressure.

WARNING: If there is ever a test which results in the inability to free fall the gear down and locked, pump the gear down, land and do not resume flight until the problem has been identified and corrected.

6. If you had Free-fall trouble with any of the gear, then ground inspection and adjustment **MUST** be made prior to your next flight. Repeat the ground cycling procedure until all the gear is free-falling well. Then go back up and repeat this test procedure. Normal flight can not be made until this free-fall test is successful.

(As a final note, it should be mentioned that the free fall test has an extremely high percentage of first flight test successes.

This concludes the chapter on the landing gear hydraulic systems.



CHAPTER 15 REVISION LIST



The following list of revisions will allow you to update the Lancair 320/360 construction manual chapter listed above.

Under the "Action" column, "R&R" directs you to remove and replace the pages affect by the revision. "Add" directs you to insert the pages shown and "R" to remove the pages.

Page(s) affected	Current Rev.#	Action	Description
15-1 thru 15-10	0	None	
15-11	B3	R&R	-
15-12 thru 15-18	0	None	
15-19	B3	R&R	-
15-20 thru 15-27	0	None	
15-28	B6	R&R	Added figure 15-9a
15-29 thru 15-31	0	None	



15-i

Chapter	6/4-1-99
CONTROL SYSTEMS/RIGGING	



CHAPTER 15: CONTROL SYSTEMS / RIGGING

REVISIONS

From time to time, revisions to this assembly manual may be deemed necessary. When such revisions are made, you should immediately replace all outdated pages with the revised pages. Discard the out dated pages. Note that on the lower right corner of each page is a "revision date". Initial printings will have the number "0" printed and the printing date. All subsequent revisions will have the revision number followed by the date of that revision. When such revisions are made, a "table of revisions" page will also be issued. This page (or pages) should be inserted in front of the opening page (this page) of each affected chapter. A new "table of revisions" page will accompany any revision made to a chapter.

Arrows

Most drawings will have arrows to show which direction the parts are facing, unless the drawing itself makes that very obvious. "A/C UP" refers to the direction that would be up if the part were installed in a plane sitting in the upright position. In most cases the part shown will be oriented in the same position as the part itself will be placed during that particular assembly step. However, time goes on and changes are made, so careful attention should be paid to the orientation arrows. That old cartoon of the guy agonizing over the plans for his canoe, built one end up, one end down, should not happen in real life. Especially to you.

CONTENTS

1. INTRODUCTION
2. DRAWING LIST
3. SPECIAL PARTS, TOOLS & SUPPLIES LIST
 - A. PARTS
 - B. TOOLS
 - C. MATERIALS & SUPPLIES
4. PROCEDURE
 - A. STICK ASSEMBLY
 - B. AILERON CONTROL SYSTEM INSTALLATIONS
 - C. CONTROL STICK ASSEMBLY TO AILERON IDLER ARM
 - D. AILERON IDLER ARM TO OUTBD BELLCRANK
 - E. AILERON BELLCRANK TO CONTROL HORN ON AILERON
 - F. AILERON CONTROL ADJUSTMENTS & LIMIT STOPS
 - G. AILERON ADJUSTMENT CORRECTIONS
 - H. ELEVATOR IDLER ARM
 - I. ELEVATOR IDLER ARM ATTACH BRACKET
 - J. ELEVATOR PUSH ROD INSTALLATION
 - K. ELEVATOR CONTROL ACCESS PANELS
 - L. ELEVATOR CONTROL ADJUSTMENTS & LIMIT STOPS
 - M. RUDDER
 - N. FLAPS

1. INTRODUCTION

This chapter will address each control system and adjustment.



2. DRAWING LIST

Drawing	Page	Title
15-1	7	Main spar web attach brackets
15-2	8	Crossover weldment installation
15-3	11	Aileron control system
15-4	17	Aileron travel range
15-5	19	Elevator idler arm / bob-weight
15-6	21	Elevator idler arm assembly
15-7	25	Access panel, elevator control horn
15-8	25	Push rod assembly
15-9	27	Elevator travel stops
15-10	30	Establishing rudder travel



LANCAIR[®] 320FB

15-3

Chapter 15

REV.

0 / 11-1-91

CONTROL SYSTEMS / RIGGING

3. EQUIPMENT REQUIRED - SPECIAL PARTS, TOOLS & SUPPLIES

A. Parts
•



15-4

Chapter 15	REV.	0 / 11-1-91
CONTROL SYSTEMS / RIGGING		

B. Tools

- drill motor
- drill bits: 1/2"
#12
#30
- hammer
- hack saw
- tape measure
- rotary grinder (Dremel or equiv.)
- 5-10 lb weight bags (2)
- 3/8" socket and ratchet wrench (2)
- flat file
- protractor, degree reading



C. Materials & supplies

- epoxy
- flox
- BID cloth
- micro
- sandpaper, assorted grit
- Duct tape or release tape
- MC or acetone for cleaning
- zinc chromate paint
- top coat for applying over zinc chromate (on pushrods)



4. PROCEDURE

A. Stick assembly

1. The control stick assembly will attach directly to the main spar web via the two attach brackets fabricated out of phenolic. Refer to figure 15-1. The "Stick Crossover Weldment", figure 15-2, will attach directly to these two phenolic brackets with the AN4-11 bolts using AN310-4 castle nuts and cotter pins. See figure 15-2 for proper orientation onto the attach brackets.

NOTE: You might find it easiest to first assemble the sticks and their linking push rod prior to installing into the fuselage.

Main Spar Web Attach Brackets

Figure 15-1

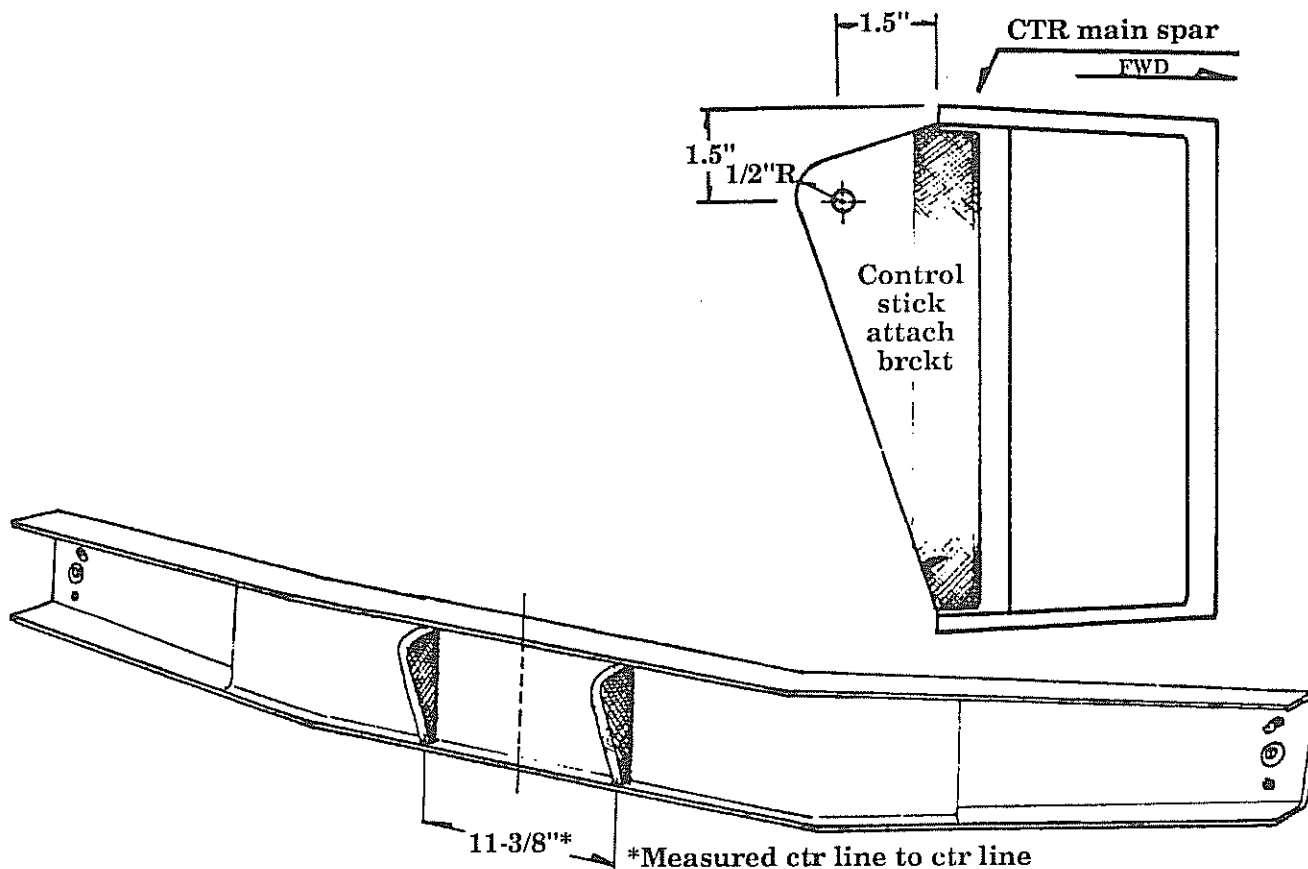

CROSSOVER WELDMENT INSTALLATION

Figure 15-2

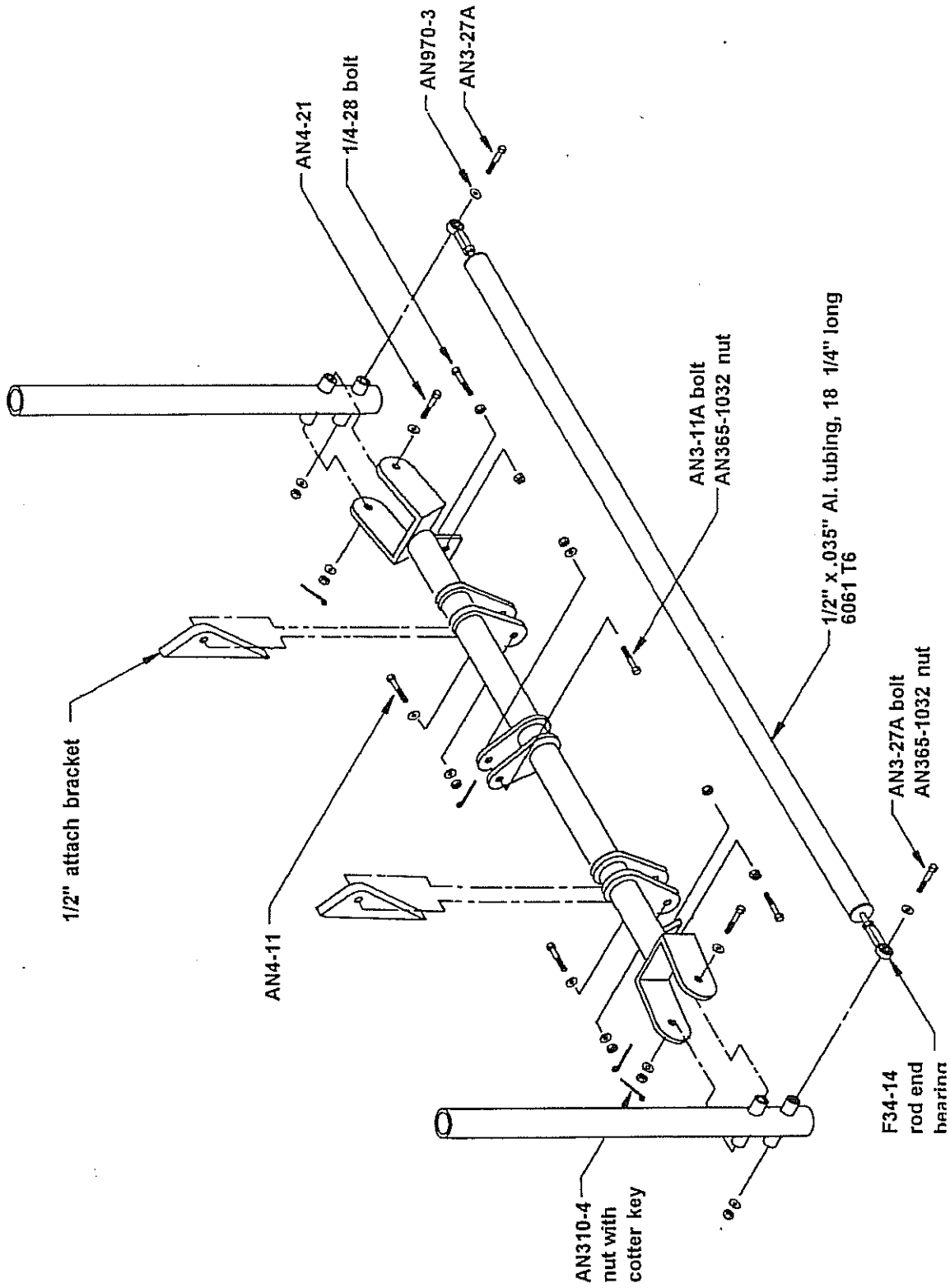

2. Install the two control sticks using the AN4-21 bolts with AN310-4 castle nuts with cotter pins. The sticks should be positioned with the longer portion of the pivot bushing to the fwd side of the stick tube itself. Place a small dab of grease on the bolt prior to inserting into the assembly. Also, the nuts should be set such that there is no "slop" yet the side to side rotation of the stick is smooth and easy.
3. Make a push rod tube (AL-1) that will connect the lower ends of each stick, see figure 15-3. This 1/2" O.D. tube should be cut 18-1/4" long. Insert the rod ends (AN490HT-8P) and secure them with two rivets each. These rivets must be "peened" over with a hammer, do not use a rivet squeezer.
4. Thread the check nuts (AN315-4) and follow with the rod end bearings (F34-14). Adjust these rod ends until, when placed on the lower end of the stick, the sticks are positioned parallel to each other. Set the rod end bearings by tightening the jam nut against them. Temporarily slip this assembly together using the AN3-27A bolts. (These bolts will be too long until the additional aileron push rods are attached, but it will still help hold it together for now.)

NOTE: The control sticks are made to accept a stick handle with a 3/4" I.D. (inside diameter). You may wish to trim the control sticks down but you should have your stick handles first since they will contribute to the overall length of the control stick assembly.



B. Aileron Control System Installations

Also refer to page 10-16, "Aileron Travel Limits". Some of that section will be duplicated here.

1. See the Aileron breakdown drawing, figure 15-3. The aileron idler arms should be fabricated using the drawings in figure 2-10. It is recommended that the alternate AL-3 attachment location be used, see "NOTE" on figure 2-10.
2. The aileron bellcranks should be fabricated and installed (see pages 9-16 through 9-24), and the aileron control horns should also be installed (page 10-11, figure 10-5). You are now ready to install the remaining pushrods, see figure 15-3.



QTY	#	Description
1	AL-1	1/2" tubing, 18 1/4"
2	AL-2	3/4" tube 20.0"
2	AL-3	3/4" tube 65"
2	AL-4	1/2" tube 10.25"
2	AL-5	.125 Alum. idler arm
2	AL-6	Phenolic
4	AL-7	1" x 2" angle bracket x 4"
2	AL-8	.090" Alum. control horn
2	AL-9	1" x 2" angle bracket

AILERON CONTROL SYSTEM FIGURE 15-3

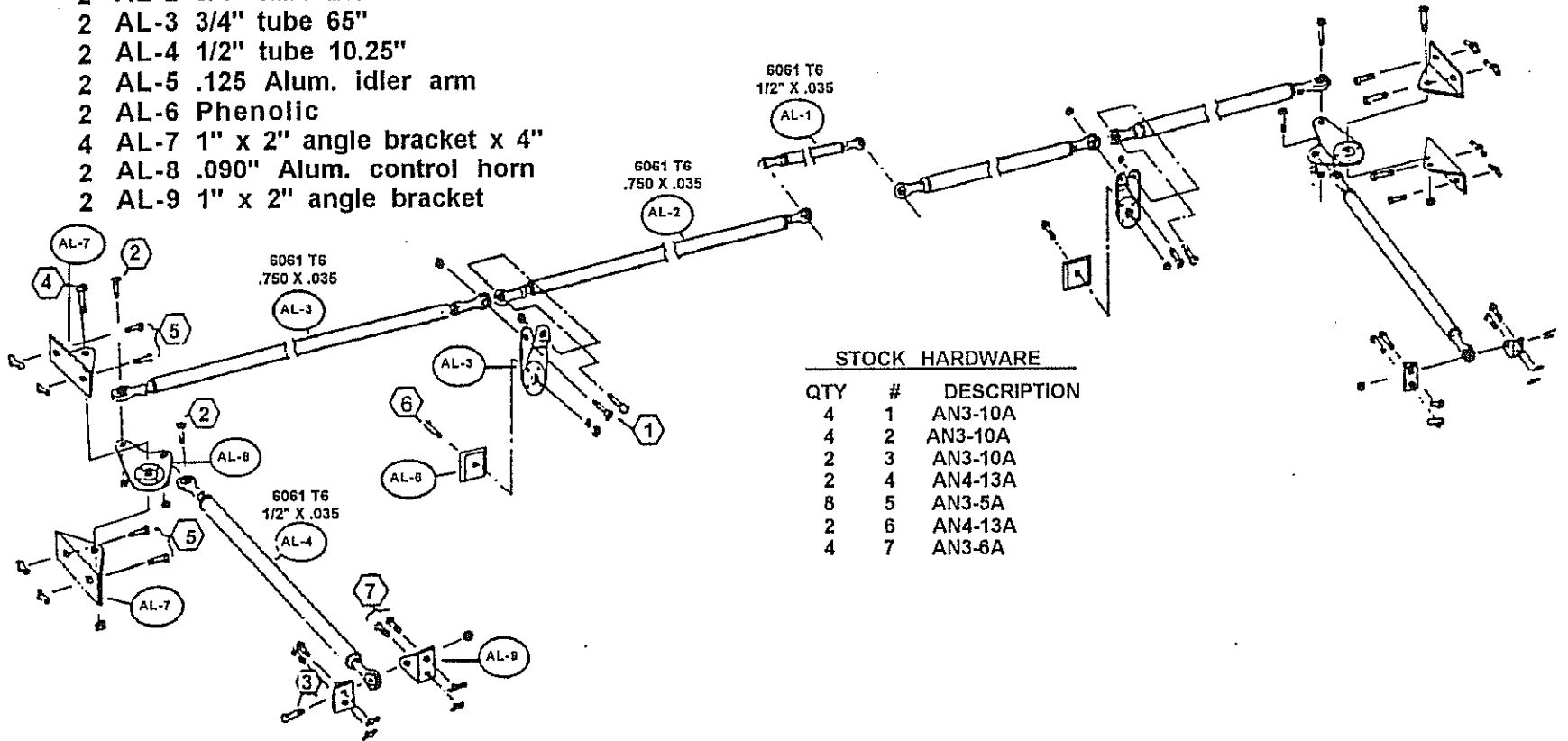

STOCK HARDWARE

QTY	#	DESCRIPTION
4	1	AN3-10A
4	2	AN3-10A
2	3	AN3-10A
2	4	AN4-13A
8	5	AN3-5A
2	6	AN4-13A
4	7	AN3-6A



C. Control stick assembly to aileron idler arm

1. The AL-2 push rods (3/4" diameter) will attach between the control sticks and the aileron idler in the stub wing. They will therefore be transitioning through the cockpit closeout ribs. See page 4-20, figure 4-12 for the approximate clearance hole required.

WARNING: This AL-2 push rod clearance hole in the close out rib must be kept small to maintain structural integrity. The hole must not be more than 10% larger than indicated in figure 4-12 on page 4-20.

2. Measure for the proper required length of the AL-2 push rods.

NOTE: For adjustment of the AL-2 push rods, hold the stick assembly in the vertical position and place the idler arms such that the two push rod attachment holes at its top are equidistant (measured left to right) from an imaginary line projected straight up from the lower 1/4" BC4 bearing attachment of the idler. It is very important that both left and right idler arms are in identical positions. If they are not, the ailerons will not operate with the proper travel ranges relative to one another.

3. Use a tape measure to check for the push rod length while the control stick is vertical and the aileron idler arm is also vertical (see above note). Be sure to deduct 4" from the overall length required when cutting the push rod tube. This is to allow for the rod end installations at each end of the push rod tube (you may want to first check the length again with the rod ends merely slipped and taped into position on the push rod tubes. After the length is verified, attach the rod ends with the AN470AD-4-16 rivets. Some kits may have been supplied with longer rivets (-22's), these should be trimmed to 1-1/8" in length. Thread the bearings onto the rod ends.

Attach the AL-2 push rod and check for clearance at the cockpit close out rib. The left to right action can be simulated accurately by moving the control stick full left and right until it hits the stops on the stick cross over weldment. The fwd to aft movement can not be adequately determined until the elevator linkage is attached, therefore this will be checked later.

4. When attaching AL-2 the pushrod bearings onto the stick and idler arms, check to verify that the bearing housing does not hit the stick or idler arm. If it does, a bind will result. Since the travel requirements of the system are substantial, a small washer used as a spacer is often required to shim the bearing out just a little from its attachment surface. This provides additional rotational room for the bearing housing.



D. Aileron idler arm to outbd bellcrank

1. Attach the AL-3 pushrods. Set the outbd aileron bellcrank neutral position such that 1-1/4" of travel is available in a direction outward toward the wing rib that it is attached to. This will leave a little clearance when the 1-1/8" of travel is made, see figure 9-8, page 9-17.
2. Measure for and attach these AL-3 push rods in a similar manner as used with the measure and fabrication of the AL-2 push rods. Check that there is clearance from the aluminum tube inserted through the fuel tank. There must be no contact throughout the full aileron travel range. Again, check that the bearing housings clear their attachments. Set the checkouts tightly against the bearings.



E. Aileron bellcrank to control horn on aileron

1. Next fabricate and install the AL-4 push rods which connect from the outboard aileron bellcrank to the aileron control horn. This is a 1/2" diameter push rod and uses AN490HT-8P rod ends. With the control stick still in the neutral position, attach the AL-4 push rod and set the aileron at the neutral (in-plane) position.
2. Router the access hole through the aft spar web using a drill bit first and follow up with a rotary tool to enlarge as required for adequate clearances through all ranges of aileron travel. Again, keep this hole as small as possible.



F. Aileron control adjustments & limit stops

With all the push rods connected, it is time to adjust the system and verify the proper travel ranges and limit stop.

1. See figure 15-4 for aileron travel ranges. You'll need an assistant to help perform an accurate check. Have him push the control stick to the maximum left position. Then check the upward travel of the left aileron and the downward travel of the right aileron ($\pm 1/8"$ is acceptable). Do the same with the control stick in the maximum right position.
2. It can often take a lot of back and forth adjusting of the aileron push rods until acceptable travel ranges are established. This can be frustrating if you have the symmetry off since that will adversely affect the aileron differential.

NOTE: As a helpful tip during rigging: If you find that the differential is not working out the same for one side vs. the other side, it is most likely the aileron bellcrank that is slightly out of rig, i.e., those two bellcranks are probably not aligned the same relative to the "square" of the airframe.



G. Aileron adjustment corrections

Select the aileron that does not produce as much UP travel as the other. Have someone hold the control stick in the direction of that aileron. Disconnect the AL-4 pushrod and extend it so as to produce more up aileron. Re-attach and check against the other aileron. With this adjustment, the downward travel will be minimally affected. Rigging corrections may be required elsewhere but this is a good location to first inspect and adjust.

1. The limit stops can usually be set by the maximum allowable travel within the stick assembly itself. That is, the sticks will only rotate outboard until they contact the crossover weldment (at lower portion of stick). You'll also notice that the cross over weldment also has provisions for an adjustment screw stop on each side. This can be used if desired but the natural stops are usually correct. If you choose to use the screw stops, use a 1/4" bolt with check nuts on each side of the drilled tab under the cross over weldment. Adjust as necessary on each side and lock in position with the two check nuts - one on each side of the tab.
2. When all is adjusted correctly, there should be absolutely no binding of controls and no interference fits or rubs. If when all assembled, you find a peculiar bind of any type, it may be easiest to disconnect various sections and independently check them for the bind. Otherwise, it can be difficult to determine exactly where the bind is being generated.

CAUTION: All rod end bearings must have an area washer used if the bearing is being attached in a single shear mode, i.e., if it is being bolted up to the side of a tab or controlling arm. The washer must be on the opposite side of the controlling arm attachment. This is to prevent the bearing from slipping off the bolt if it were to work loose from the rod end bearing housing into which it is installed. Use AN970-3 type washers.



Aileron travel range
CROSS SECTIONAL VIEW, MEASURE AT AILERON TIP
Figure 15-4

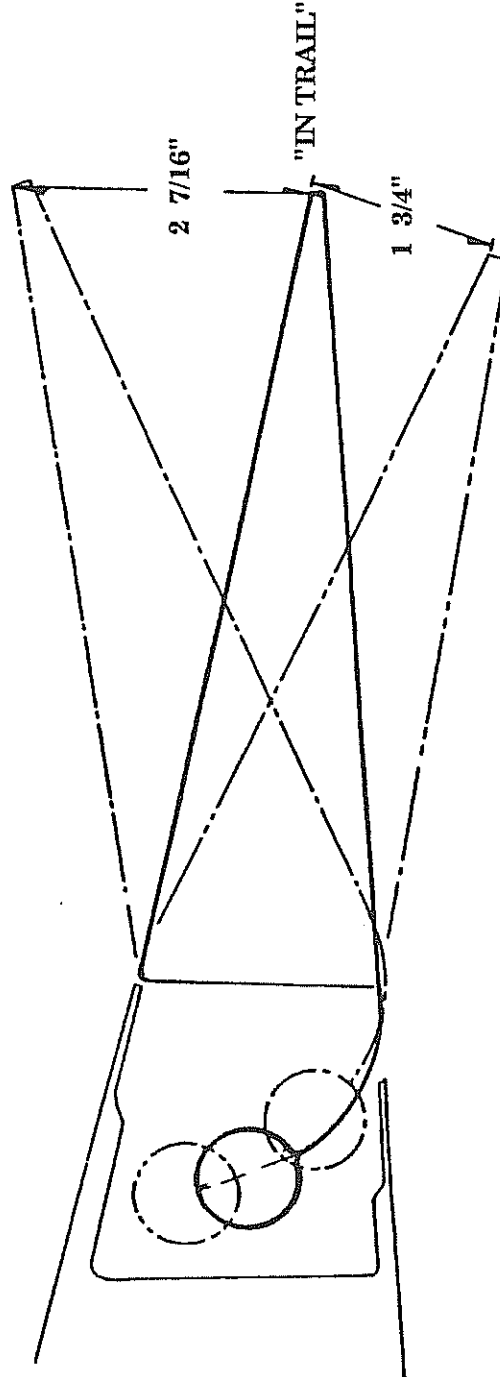

Elevators

The elevator and control horn should be already installed per instructions in chapter 7, see figure 7-7.

The elevator push rods will travel from the stick crossover weldment, over the aft spar and through the baggage bulkhead where the idler arm will be located. From there the second pushrod will route directly to the elevator control horns.

H. Elevator idler arm

1. The standard elevator idler arm on the Lancair 320 also incorporates a bob-weight system. The weighted system will introduce dynamic feedback into the elevator controls. See figure 15-5. The idler arm is required for several reasons. The primary reason is for system rigidity and also to help keep the controls low over the fuselage bottom.
2. Select the two, pre-cut idler/bob-weight arms and the two BC4 bellcrank bearings. Per figure 15-5, attach the bellcrank bearings to the idler arms using six (6) rivets AN470AD-4-6 per bearing. (You can of course install all twelve rivet locations per bearing but six is sufficient and is the minimum allowable). Note that when you place both idler arms together, the bearings will mount to the same side of each arm, they are not mounted in a mirror image fashion. In this manner, one bearing flange will be located between the two idler arms and the other bearing flange will be to the outside of the assembled idler arm system.

Check that the chamfer made in the idler arms is sufficient to accept the fillet on the bearing. The bearing flange must sit FLAT against the idler arm. File if necessary.

You may use a rivet squeezer if desired to properly set the AN470AD-4-6 rivets or peen them by hand. Use a #30 drill bit for these rivets.



Elevator Idler Arm/ Bob-Weight

Figure 15-5

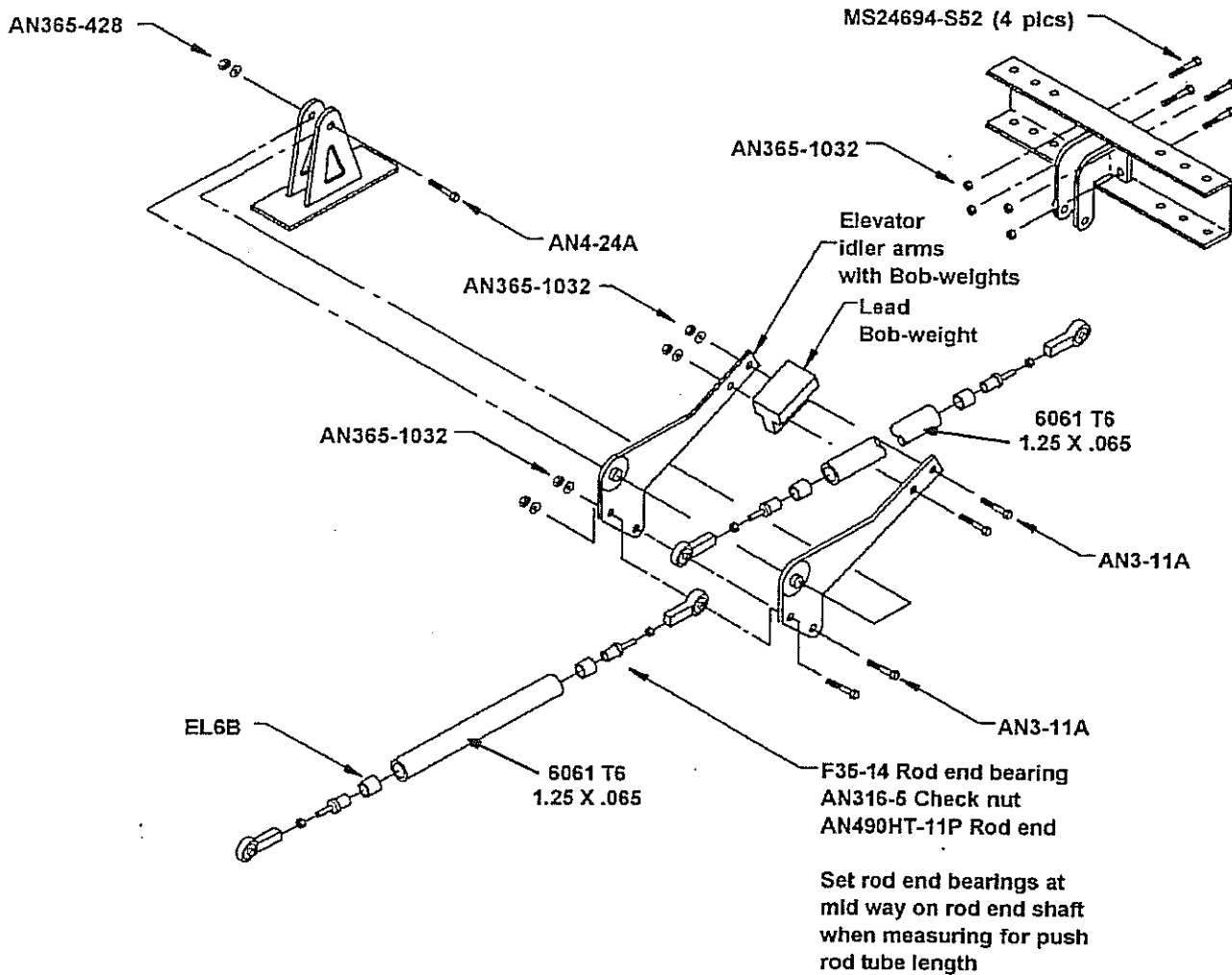

I. Elevator idler arm attach bracket

1. Next build the Elevator Idler Arm Attach Bracket, see figure 15-6.

This attach bracket is made of 1/4" plywood (excess from the firewall plywood section). Cut the two side panels and the base plate per figure 15-6. Go ahead and drill the 1/4" bolt hole in the tops and the oval slot in the middle of the side pieces. If you stack the two side pieces together during this drilling, then the holes will be well aligned.

To cut the oval slot, use a 3/4" drill bit at each end (drill centers spaced 1-1/4" apart) and complete the oval using a sabre saw (with a fine cut blade) for the side cuts.

2. Use epoxy/flox to attach the side panels to the base plate, be sure to establish the necessary spacing per figure 15-6. It is perhaps easiest to now allow this to cure.

Then add the 2 BID layup to the inside first and follow with the 2 BID on the outside. Allow to cure. This 2 BID on each side **MUST** cover the entire faces of the side plates. Place a small epoxy/flox fillet in the inside corners where the inside 2 BID will wrap around. This may be a little difficult to get in and stipple the BID but care must be used to achieve a good job on the part.

WARNING: There must be no air voids along this inside joint line. The presence of air voids could cause part failure and loss of elevator controls.

3. After the assembly has cured, use an X-acto knife to carefully trim the glass away from the oval cutout in the center of the side panels. Use a heat gun to soften the glass which will first allow for easy trimming and also provide a secondary post cure as it cools back down. Carefully trim the BID away from the 1/4" bolt hole as well.
4. The finished assembly will install onto the fuselage floor, along centerline. Locate the bracket assembly at FS-94 which is just aft of the baggage bulkhead.

NOTE: Earlier Lancair 320 plans called for the baggage bulkhead at FS-96. While this is perfectly acceptable, the idler arm bracket assembly should then be placed 1" aft of the baggage bulkhead.

5. Clean and prepare the area on the fslg floor (lower joggle seam at centerline) where the attach bracket assembly will be installed.
6. Using a generous amount of epoxy/flox under the bracket assembly, pot the assembly onto the floor in the correct location. Check that it is parallel to the centerline of the fslg and on centerline as well. Apply weights (5-10 lbs of lead shot or equiv.) during cure. Clean away any squeeze out of flox and allow to cure.

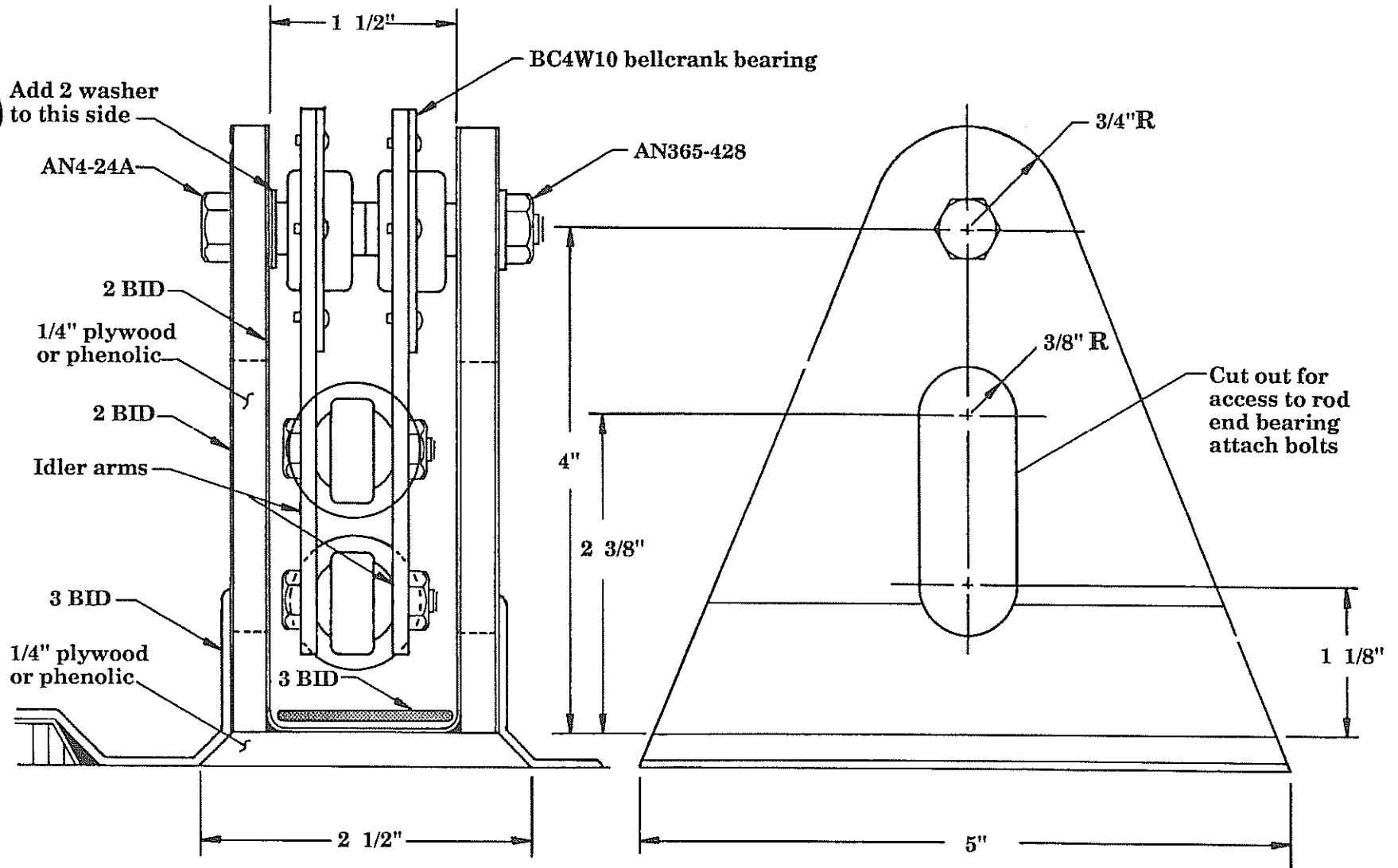

ELEVATOR IDLER ARM ASSEMBLY
FIGURE 15-6



7. Next add 3 BID tapes to both sides of the assembly and also through the center section of the bracket assembly. Contact at least 2 inches all around the assembly. The attachment BID tapes will ride up onto the honeycomb core material, use a light epoxy/flox fillet where necessary to assure a smooth, air bubble free, application of these BID tapes. See figure 15-6.
8. Next install the lead bob-weight into the two idler arms. Place a bolt temporarily through the bearings, also set one bolt through one set of the lower push rod attach bolt holes (AN3 bolt needed). These two bolt holes will hold the two idler arms in proper alignment during installation of the lead weight. See figure 15-5. Position the lead weight and use a #12 drill bit to drill through for the installation of the two AN3 attach bolts and AN365-1032 stop nuts. The lead **MUST** be positioned such that it extends above the idler arms, not below.
9. Next install the idler arms into the attach bracket in the fslg using the AN4-22A bolt. They will install such that the lead weight is to the aft side. Note that there are two AN960-416 washers placed between the inner side of the plate and the idler arm that has the bearing mounted to the **INSIDE** (nearest fslg centerline) of it. The idler arm with the bearing mounted to the **OUTBD** side will not require a washer. These two washers are to provide adequate clearance room for the bolt heads that will later attach the two elevator push rod bearings. See figure 15-6. Set the 1/4" pivot bolt with the AN365-428 stop nut.
10. The elevator idler arm assembly should be fully installed at this time. The two push rods will be later attached to them. Access to the bolts that hold the push rods will be made available through the two oval cut outs in the side plates. A standard 3/8" socket will fit through these ovals.



J. Elevator push rod installation

1. Two push rods will be installed. These are 1-1/4" x .065" 6061-T6 tubes. EL6B plugs will be installed into each end which will accept the AN490HT-11P rod ends. The rod end bearings used are F35-14 which have a 5/16" female threaded socket and an AN3 bolt hole in the bearing.
2. First set all the controls to the neutral position. The control sticks should be initially in the vertical position. The idler arm should be positioned so that the forward push rod attach hole is directly below the 1/4" pivot bolt above.
3. Use a measuring tape to accurately measure the required total length of each push rod assembly. From that measurement, deduct 4" in overall length which will account for the space taken by the two bearing assembly ends.
4. Next saw the 1-1/4" tubing to length. Use a hacksaw. Make sure the saw cuts are straight across the tube (perpendicular). File the ends flat with a flat file. Insert the EL6B machined aluminum plugs and then the rod ends (AN490HT-11P). Before you secure them with the two rivets, thread the bearings on and check the assembly for proper length by installing the push rods temporarily into the fslg (use a wrap of tape to temporarily hold the rod ends into the ends of the 1-1/4" tubes).



K. Elevator control access panels

1. The elevator push rod will require two access panels so that you can reach and attach the bolt that secures the aft push rod into the elevator control horn assembly. See figure 15-7. This will require an access hole on the right side that is large enough to allow you to reach in with your fingers, set the bearing and insert the AN3 bolt. An additional small round hole must be drilled into the left side to allow access of a 3/8" socket. With this hole, you can slip the AN365-1032 stop nut into the socket and slip that into the hole and onto the AN3 bolt. Tighten up using another 3/8" socket from the other side. A 3/4" hole is sufficient on the left side which will allow for a simple installation of a 3/4" circular panel cover that simply snaps into position.

Make a panel to close out the right side access hole from a piece of .025" aluminum or similar. Simply make it so that it fits the hole with about 1/4" overlap on the fwd, aft and bottom sides. The top will fit to the 13° DN elevator travel limit (the down limit stop will be established on the left side, see step L3, below). This larger access panel can simply be attached with silicone. Apply a good bead all around with the overlap surfaces and press the panel into position. Allow to cure with pressure against it.

2. With the push rod lengths verified, permanently install the rod ends into the 1-1/4" tubes. See figure 15-8. Use two AN470AD-4-24 rivets. These rivets must be "peened", do not use a rivet squeezer.

WARNING: When checking and adjusting the push rod lengths, the rod end bearings **MUST** be threaded onto the rod ends by at least the equivalent length of the rod end diameter. Also, the rivets that set the rod ends into the push rod must be peened. Do not use a rivet squeezer. Failure to establish these criteria could result in push rod failure and resultant control surface failure.

3. Set the rod end bearings with check nuts (AN316-5) tightened against the rod end bearing body.
4. With the push rods now completed, mask off the rod end portions of them and paint the tubes with zinc chromate. You may also wish to follow that up with a "finished" enamel, acrylic or urethane top coat paint (hardware store "rattle can" paints will work just fine).

NOTE: It is generally best to select a light colored top coat since that will allow for improved visibility of the surfaces during inspections.



Access panel, elevator control horn

Figure 15-7

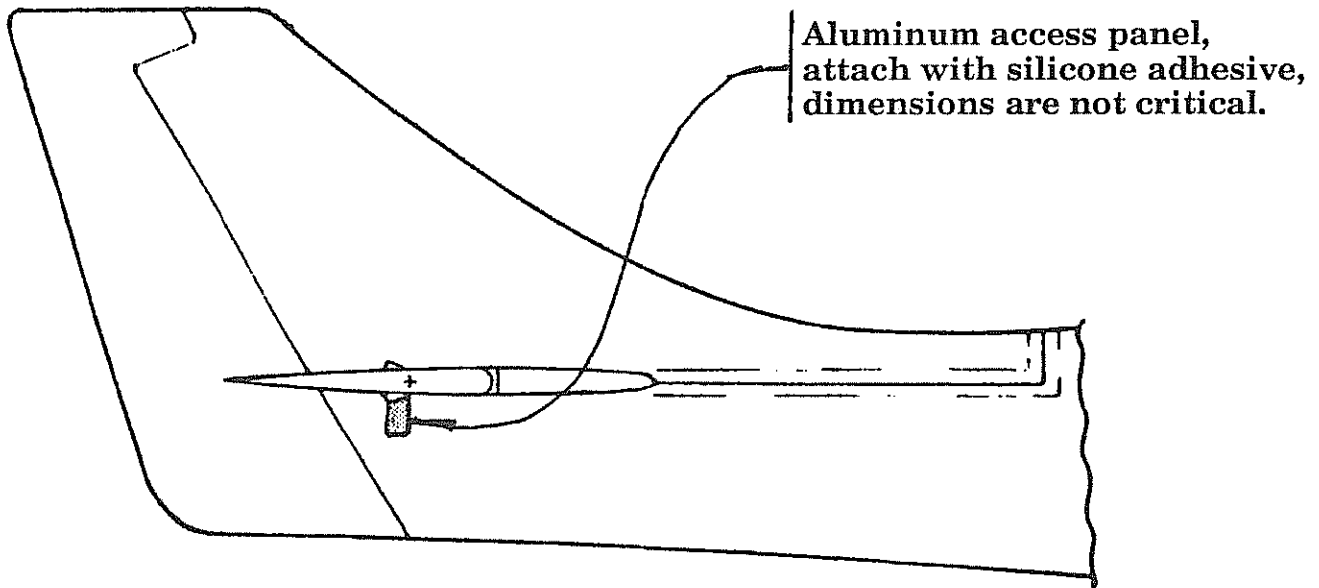

Push rod assembly

Figure 15-8

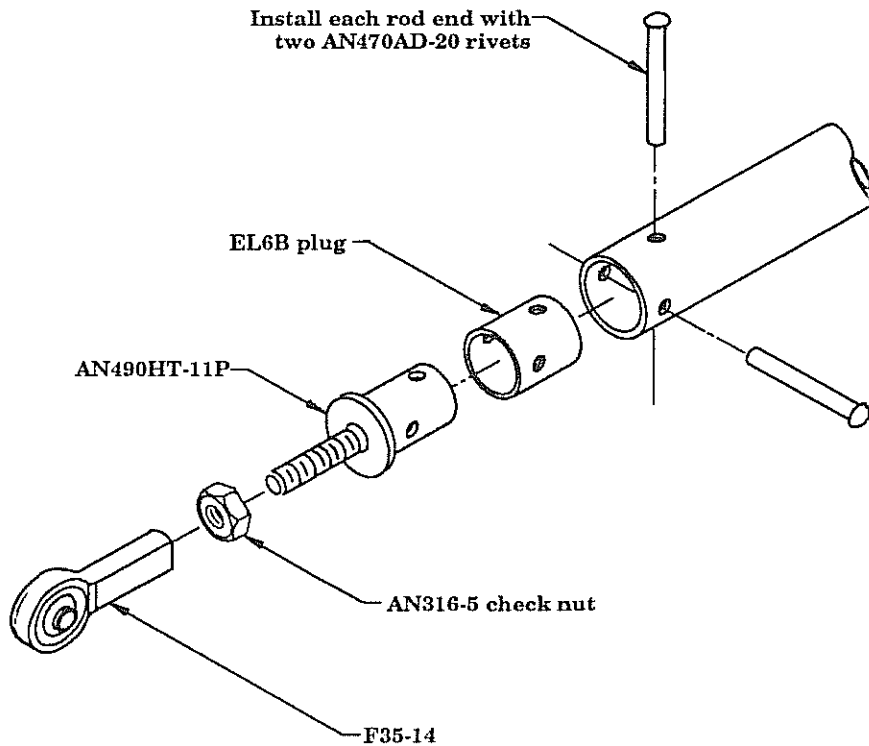

L. Elevator control adjustments & limit stops

With the push rods completed you'll need to establish proper adjustment of the system.

1. Connect the push rods (it is best to simply slip the rod end bearing attach bolts and omit the nuts for now since you'll likely be making several small adjustments of the bearings which will require frequent removals and you'll get real tired of installing and removing the stop nuts. Also the stop nuts will get worn out and would require replacement since they should not be used more than three times).

With the stick in the vertical position, the elevator should also be in the neutral position.

2. Place a degree reading protractor on the elevator and if it's adjustable, set it to zero. If it is not adjustable, then simply note the angle it is reading.

IMPORTANT: The correct elevator travel range is 27° UP and 13° DOWN.

3. The travel stops for the elevator must be established back where the elevator crosses through the tail cone. The clearance cut must be set to establish these control limits. If adjustment is required either clearance more for additional travel range or if less is required, cut a small phenolic block and insert it into the clearance hole, align and bond to the inside of the skin with structural adhesive. See figure 15-9.

4. Raise the elevator until the degree reading protractor reads 27° up. Set the clearance hole to allow only that amount of upward travel.

5. Lower the elevator to establish the 13° down travel limit.

6. Now sit in the cockpit and verify that in your normal seated position, you will actually be able to reach the control limit stops by moving the control stick. If necessary, adjust the control stick forward or aft to achieve full available travel from the cockpit. This can be accomplished by adjusting the rod end bearings on the push rods.

EXAMPLE: if you are unable to pull the stick back far enough to achieve full up elevator then you'll have to establish the neutral position of the stick farther forward. To do this, lengthen the forward push rod slightly.



Elevator travel stops

Figure 15-9

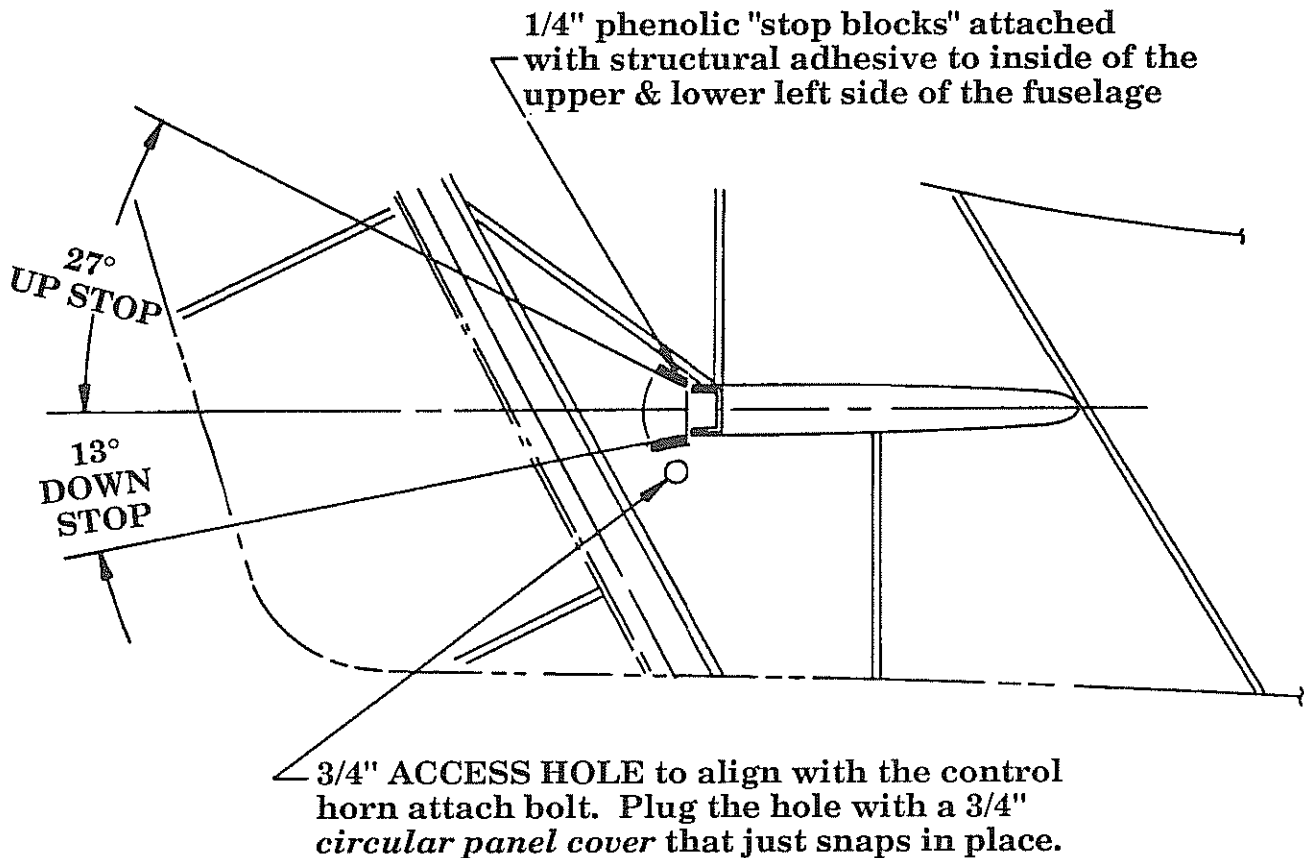

7. There are three additional KEY checks that must be made and will affect available travel.
 - a. The most forward position that the stick assembly can be set at is established by the required clearances needed between the forward most push rod bearing and its clearance from the top of the stick crossover weldment. If a more forward control stick position were needed, then you would have to modify the control stick itself to lean forward.
 - b. The bob-weight must have positive clearance from the aft push rod when the elevator is positioned into the most DOWN position. If the lead weight contacts the aft push rod in the 13° DOWN position, then the aft push rod will have to be shortened. And to keep the control stick in the same position, the forward push rod will have to be lengthened by approximately the same amount. This will then have the net effect of raising the bob-weight assembly for the same elevator position and control stick orientation.



- c. The elevator idler arm attach bracket side plates must have sufficient clearance away from the two AN3 bearing attach bolts that fit through the bottom of the idler arms. Swing the system back and forth to verify positive clearances. If your dimensions are correct though, this should not be a concern.
8. With all the control checks made and all limit stops established, the elevator control system is complete.
 9. Since you will likely have the system apart again, (probably during airframe painting, etc.), be certain that when you finally do install the pushrods back into the airframe, you use stop nuts to secure all the bearings.
 10. Finally, with the elevator controls fully installed, check that the aileron AL-2 push rod will still have positive clearance from the cockpit closeout rib throughout the full elevator travel ranges (as the control stick is moved fwd to aft, the aileron AL-2 push rod will also swing fwd to aft and thus affect the clearance needed in the cockpit closeout rib).

Set the Elevator Rigging

Figure 15-9a

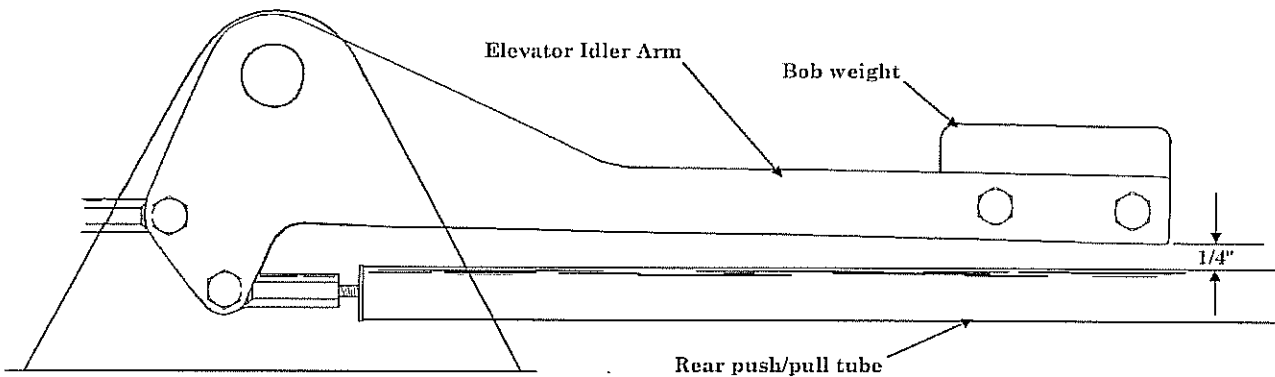

With the control stick all the way forward, the elevator should be on the down stop and the bob weight should be 1/4" off the rear push pull tube. This will set the proper rigging for the elevator.



M. Rudder

This will complete installation of the rudder pedal assembly and the rudder must be installed (it need not be locked into position, merely dropped onto its pivot pin bushings on the vertical tail post).

Refer to figure 15-10 for travel range measurements.

1. The rudder control stops should already be set per chapter 8, section G titled "Rudder travel stops" on page 8-33.
2. While seated in the cockpit, push the rudder pedals and have someone at the tail to verify that you are in fact, reaching the limit stops positioned into the vertical fin area down at the rudder control horn. Control movement should be smooth and the limit stops should be attainable.





Establishing Rudder Travel

Figure 15-10

30° Right Rudder, 25° Left Rudder

To check and establish the rudder travel limits, find a section on the rudder where the chord is 9-1.2" and use it simply as a reference point (the top of the rudder just below the counterbalance section is adequate). At this point, standing behind the rudder, you'll have 30°s right rudder when you achieve a 5" dimension as shown below. 25°s left rudder will be established when you achieve a 4-1/8" dimension

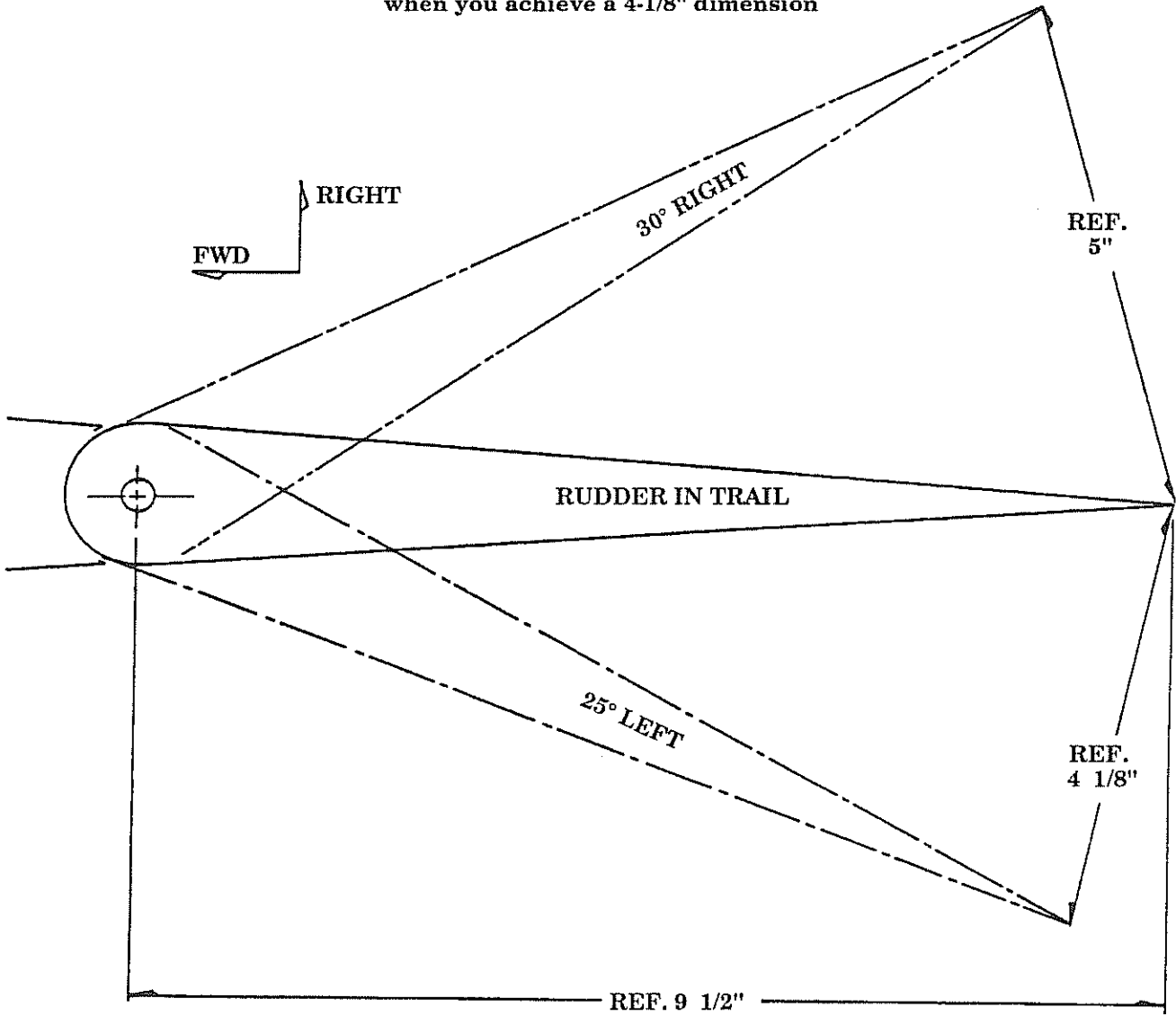

N. Flaps

1. The adjustment of the flap linkage is covered beginning on chapter 10, page 10-30 "Flap pushrod installations and adjustments".
2. The flaps are actuated via the electric linear actuator and the accompanying custom micro switch unit that installs onto the actuator. The micro switch adjustments will be covered in chapter 18 "Electrical Installations".

This concludes this chapter



CHAPTER 16 REVISION LIST



The following list of revisions will allow you to update the Lancair 320/360 construction manual chapter listed above.

Under the "Action" column, "R&R" directs you to remove and replace the pages affect by the revision. "Add" directs you to insert the pages shown and "R" to remove the pages.

Page(s) affected	Current Rev.#	Action	Description
16-1 thru 16-38	0		
16-39	6	R&R	Enlarged NACA scoop template
16-40	6	R&R	Enlarged NACA scoop template
16-41 thru end	0		



16-i

Chapter	6/4-1-99
COCKPIT INSTALLATIONS	



CHAPTER 16:

COCKPIT INSTALLATIONS

REVISIONS

From time to time, revisions to this assembly manual may be deemed necessary. When such revisions are made, you should immediately replace all outdated pages with the revised pages. Discard the out dated pages. Note that on the lower right corner of each page is a "revision date". Initial printings will have the number "0" printed and the printing date. All subsequent revisions will have the revision number followed by the date of that revision. When such revisions are made, a "table of revisions" page will also be issued. This page (or pages) should be inserted in front of the opening page (this page) of each affected chapter. A new "table of revisions" page will accompany any revision made to a chapter.

Arrows

Most drawings will have arrows to show which direction the parts are facing, unless the drawing itself makes that very obvious. "A/C UP" refers to the direction that would be up if the part were installed in a plane sitting in the upright position. In most cases the part shown will be oriented in the same position as the part itself will be placed during that particular assembly step. However, time goes on and changes are made, so careful attention should be paid to the orientation arrows. That old cartoon of the guy agonizing over the plans for his canoe, built one end up, one end down, should not happen in real life. Especially to you.

CONTENTS

1. INTRODUCTION
2. DRAWING LIST
3. SPECIAL PARTS, TOOLS & SUPPLIES LIST
 - A. PARTS
 - B. TOOLS
 - C. MATERIALS & SUPPLIES
4. PROCEDURE
 - A. SEAT BACK BULKHEAD
 - B. SEAT PANS INSTALLATION
 - C. FLAP PUSH ROD CLOSEOUT PANEL FOR SEAT
 - D. INSTRUMENT PANEL INSTALLATION
 - E. CENTER CONSOLE POSITIONING & SEAT BELT ATTACH POINT
 - F. PITCH TRIM INSTALLATION
 - G. PITCH TRIM ADJUSTMENTS
 - H. CONSOLE GLOVE BOX INSTALLATION (OPTIONAL)
 - I. SIDE ARM REST INSTALLATIONS
 - J. SHOULDER STRAP INSTALLATIONS
 - K. NACA DUCT INSTALLATIONS (COCKPIT VENTILATION)
 - L. PITOT / STATIC INSTALLATION - HOMEMADE PITOT TUBE INSTALL
 - M. AN5812 STANDARD PITOT TUBE INSTALLATION
 - N. STATIC PORT INSTALLATION

1. INTRODUCTION

This chapter will address installations within the cockpit. Since one installation will usually have some effect on the next, it is again recommended that you read this entire chapter prior to performing these installations.



16-2

Chapter 16	REV.	0 / 11-1-91
COCKPIT INSTALLATIONS		

2. DRAWING LIST

Drawing	Page	Title
16-1	16-7	Seat back bulkhead
16-2	16-8	Seat back patterns
16-3	16-10	Seat back and support stiffener
16-4	16-11	Seat pan
16-5	16-12	Seat pan fwd retaining lip
16-6	16-13	Seat pan cut out for control sticks
16-7	16-14	Seat close out panel
16-8	16-15	Instrument panel
16-9	16-16	Wood instrument panel pattern
16-10	16-18	Radio box support
16-11	16-19	Center console
16-12	16-20	Center console
16-13	16-21	Elevator trim arm attach
16-14	16-22	Console / instrument panel
16-15	16-23	Console / seat belt attachment
16-16	16-24	Console top
16-17	16-27	Elevator pitch trim
16-18	16-28	Elevator pitch trim breakdown drawing
16-19	16-30	Console glove box
16-20	16-31	Glove box
16-21	16-33	Side arm rest
16-22	16-34	Shoulder strap attachment
16-23	16-35	Shoulder strap attachment
16-24	16-37	NACA duct position
16-25	16-39	NACA duct layout
16-25	16-40	NACA duct layout (intentional duplicate of page 16-39)
16-26	16-41	Pitot tube (home made)
16-27	16-43	Pitot tube (commercial heated type)
16-28	16-44	Static port location
16-29	16-45	Static port installation



3. EQUIPMENT REQUIRED - SPECIAL PARTS, TOOLS & SUPPLIES

A. Parts

- Pre-molded seat bottom panels
- Pre-molded instrument panel (optional)
- Elevator pitch trim components - see figure 16-18, page 16-28.
- Hinge for glove box (optional)
- Shoulder straps (optional)
- NACA ducts and eyeball vents (optional)
- Pitot tube



16-4

Chapter 16

REV. 0 / 11-1-91

COCKPIT INSTALLATIONS



B. Tools

- drill motor
- drill bits: 1/4", preferably long shanked
#12
#40
- sabre saw
- small level
- tape measure
- rotary grinder (Dremel or equiv.)
- 5-10 lb weight bags (2)
- aluminum type hole punch (for instrument panel cut-outs)
- assorted files
- Unibit (cone shaped multiple diameter drill bit - very handy)
- pop rivet tool
- sharp matt or X-acto knife



C. Materials & supplies

- epoxy
- flux
- BID cloth
- micro
- sandpaper, assorted grit
- Duct tape or release tape
- MC or acetone for cleaning
- cardboard for templates
- 1/2" white Clark foam or 3/8" Nomex® honeycomb panel
- about a dozen pop rivets
- 1/4" phenolic material for hard points
- instant or hot glue



4. PROCEDURE

A. Seat back bulkhead

This is a relatively simple bulkhead that can be somewhat tailored to your seating position and desires. It is however recommended that the bulkhead be positioned so as to provide the maximum allowable room. If you desire less (i.e., more upright seating position) then use the upholstery cushioning to achieve a more vertical seat back angle (you can always pad it up but it's much harder to make it bigger once you have it locked in a position).

The seat back **MUST** attach to the top of the aft center spar cap. From that base point, it can be leaned back to an angle that suits you. We strongly recommend the position that places this bulkhead top position at a point that is approximately 1" aft of the aft deck roll over fwd face (as measured at the top longeron position). See figure 16-1.

SEAT BACK BULKHEAD

SIDE VIEW

Figure 16-1

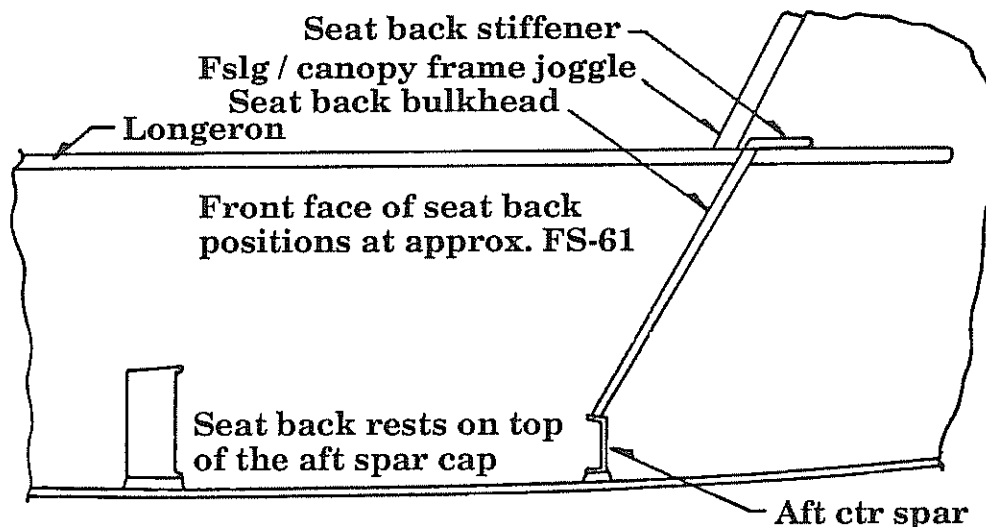

1. The seat back will be made from a bulkhead consisting of 1/2" white foam (or 3/8 Nomex® honeycomb) with 2 BID per side. Refer to Blueprint "B" for initial patterns for the seat back sides. Start with these patterns and make two cardboard templates. Make these templates wide enough that they can be overlapped and taped together when adjusted into the fslg. See figure 16-2.

2. Position the templates against the inside of the fslg along a line from the L.E. of the aft spar cap to an upper point about 1" aft of the intersection of top longeron & aft roll over brace. Adjust the contour as necessary to generate a good fit. Then tape the patterns together to generate the proper orientation of the side patterns and the proper width across the cockpit. This will serve well as an accurate pattern from which you can cut the actual bulkhead.

SEAT BACK PATTERNS

Figure 16-2

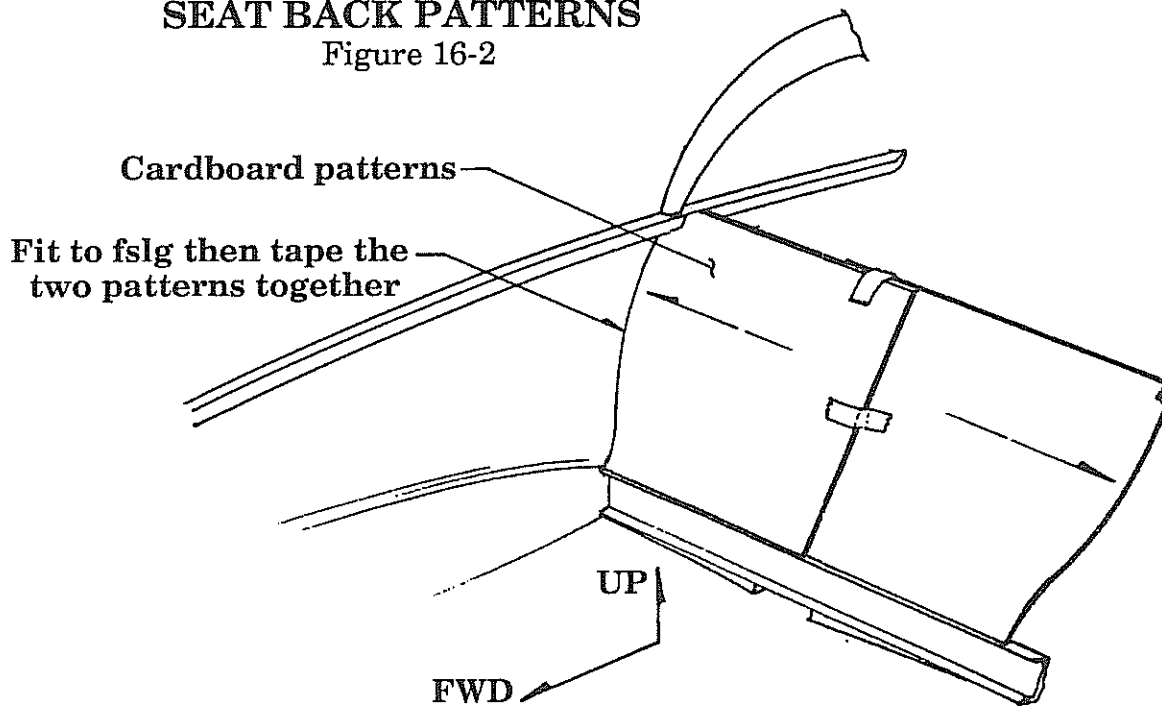

3. Cut the bulkhead out of either the 1/2" white foam or the optional Nomex® honeycomb panel. Establish 2 BID per side. Sand the bottom of the bulkhead panel to form a bevel so that it mates well with the top of the aft spar cap. The panel can sit aft of the leading edge of the spar cap by 1/4". This will provide the maximum possible length of the cockpit seating area. See figure 16-3.

4. Locate the center of the seat back and make a 2-3/4" wide cutout across the middle (at the bottom). This cutout should extend to what will be the top of your center console which is normally 11" above the floor of the cockpit as measured just in front of the aft spar.

NOTE: If you would like to make possible adjustments to the center console height, then simply make a cutout 10" up from the cockpit floor and you can easily cut additional material out at a later time when you've located the top of the console which can be adjusted up or down slightly for comfort. REMEMBER the dimensions listed above are measured up from the FLOOR, NOT UP FROM THE BOTTOM OF THE SEAT BACK BULKHEAD - THAT DIMENSION WILL BE LESS. Use a tape measure and a small level (with the fslg levelled) to establish this position on your seat back.

With the fit established, cut back the foam slightly around the two sides and the bottom of the bulkhead and use epoxy/micro to pot the bulkhead into permanent position on the fslg. Be sure to properly clean and sand the sides of the fslg and spar cap first.

5. Next add a 2 BID (3" wide) tape around the perimeter (left side, bottom and right side) of the bulkhead fwd face. Add a similar 2 BID around the perimeter on the aft face (use a micro fillet to help the BID tapes transition over the top spar cap, see figure 16-3). Allow to cure.
6. From a piece of 1/2" white foam, cut and fit the top seat back stiffener. It will be made 3" wide and will sit on top of the seat back and on top of the longeron tops. See figure 16-3.
7. Use micro / epoxy to pot it into position and 2 BID to attach it to the seat back and fslg sides. Note that the top 2 BID attach tapes will be wider than normal and will thus extend across the full width of the top of this stiffener. The stiffener will thus end up with 4 BID across its upper surface. The aft or lower 2 BID attach should be 3" wide tapes.
8. After you have established the final size of the center cutout (at the console position), you must apply a 2 BID attachment tape around this perimeter. This can be applied after the console sides are attached and prior to attaching the console top. (Also see section on console installation).



SEAT BACK AND SUPPORT STIFFENER CROSS SECTIONAL VIEW

Figure 16-3

Build this section on a bench, then bond into position and attach with the 2 BID tapes top and bottom.

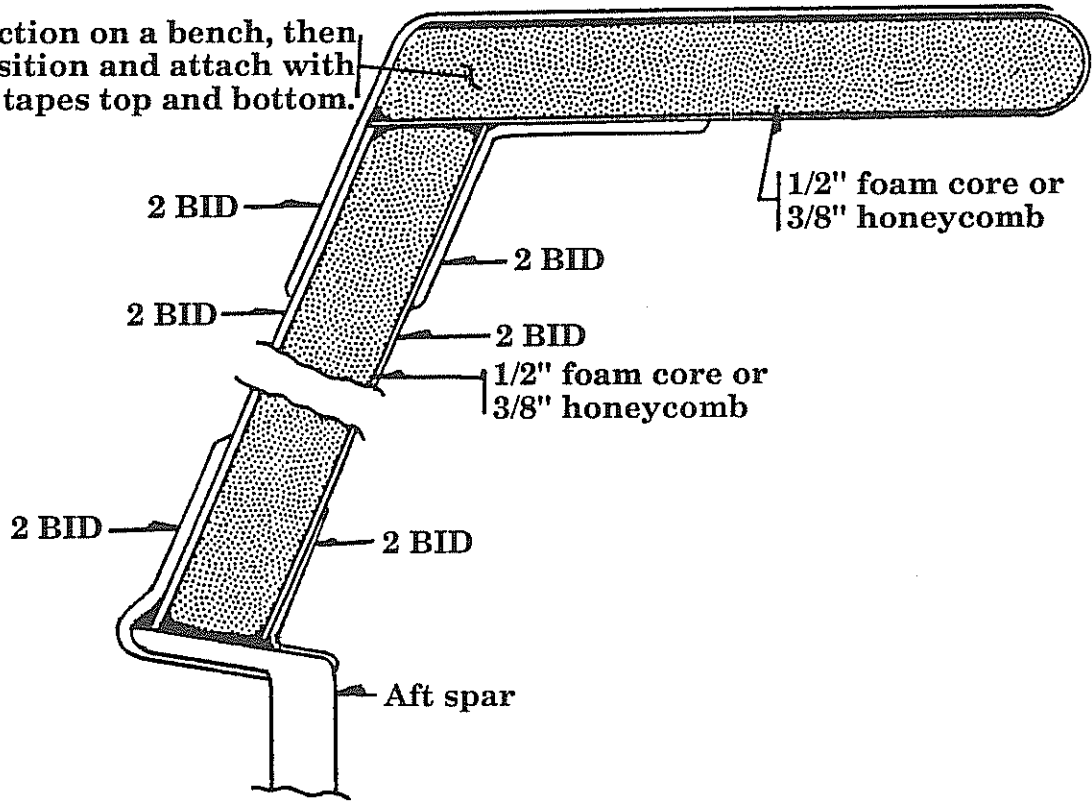

B. Seat pans installation

The seat pans are made from the supplied pre-molded seat bottom panels. These may be shipped as one piece which will then require splitting into two halves or they may already be split into two separate halves when you receive them. Also a closeout panel (removable) will be made to close off the flap push rod tubes, this is made from a flat panel.

1. First you'll need to mark a line on the fslg where the console sides will fit. You can also go ahead and make the console side (see section E., "Center console installation" in this chapter) and temporarily position them in the cockpit. We recommend that you install the seat pans before the console sides since you may wish to modify the console height but you'll need the seats installed with some temporary seat cushioning laid into position in order to make that determination.

SEAT PAN

FIGURE 16-4

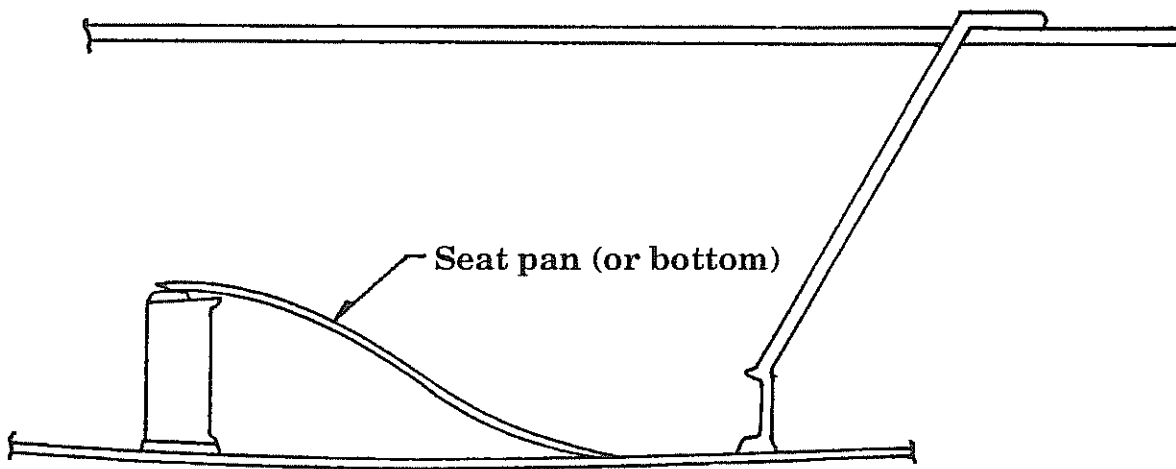

2. Cut the seat bottom to fit inside each side of the cockpit. You will have a little fwd / aft adjustment of the seat pan. This is a matter of comfort and also establishment of adequate clearance from the control stick and cross over weldment. The fwd end of the seat bottom will rest on the spar cap and the aft end will rest on the floor.
3. Trim the outbd fwd edges of the seat pans to clear the load transfer pads. Do not simply cut a notch in the seat bottom for the "web" of that load transfer pad since upon completion, the seat bottom will have to be slid aft about a half inch to be removed from its installation point.

SEAT PAN FWD RETAINING LIP

Figure 16-5

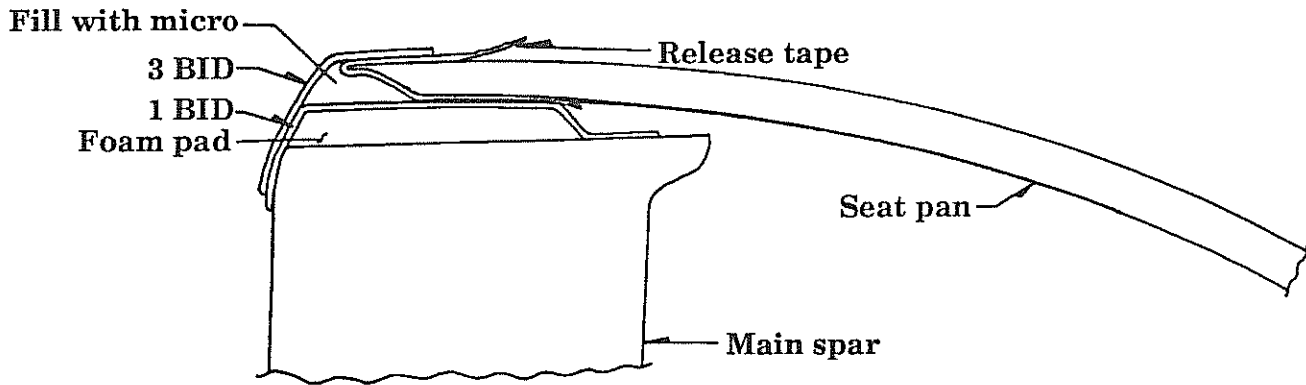

4. The aft end of the seat bottoms will sit on the fslg bottom. This bottom is slightly curved so the seat pan T.E. will not be a perpendicular cut but rather an angled cut which effectively makes for a longer seat bottom panel on the inbd side as compared to its outbd side. Adjust this cut until the seat bottom sits flat on the fwd main spar cap and also the fslg bottom.
5. Make the cutout in the seat pan for the control stick. With the seat in position, make sure that you can rotate the stick throughout its full travel ranges and not contact the seat bottom. There must also be about 3/8" clearance under the seat bottom from the top of the stick crossover weldment at any point. This will sometimes require a foam pad or doubler which can be fibreglassed on top of the main spar cap thus raising the L.E. of the seat bottom and creating greater clearances for the crossover weldment. Usually a 1/4" doubler is all that is ever required. If this is needed, simply use micro to pot the 1/4" foam pad onto the spar cap and cover it with a 1 BID ply that laps onto the spar by 3/4" fwd and aft. See figure 16-5.

WARNING: You must sit in the cockpit and allow your body weight to rest on the seat pans in order to determine the positive clearance of the seat pan from the control system. There must be no contact of the seat pan onto the controls. Failure to properly establish this positive clearance could result in a system jam and possible loss of adequate controllability during flight.

6. The sides of the seat pans should have clearance from the sides of the fslg by about 1/2" and clearance from the center console by about 1/4".
7. With the seat pan and its position located, cover the fwd edge of the seat bottom with plastic tape. This should wrap about 3" on both the upper and lower surfaces. It will be used as a "release".

SEAT PAN CUT OUT FOR CONTROL STICKS

TOP VIEW

Figure 16-6

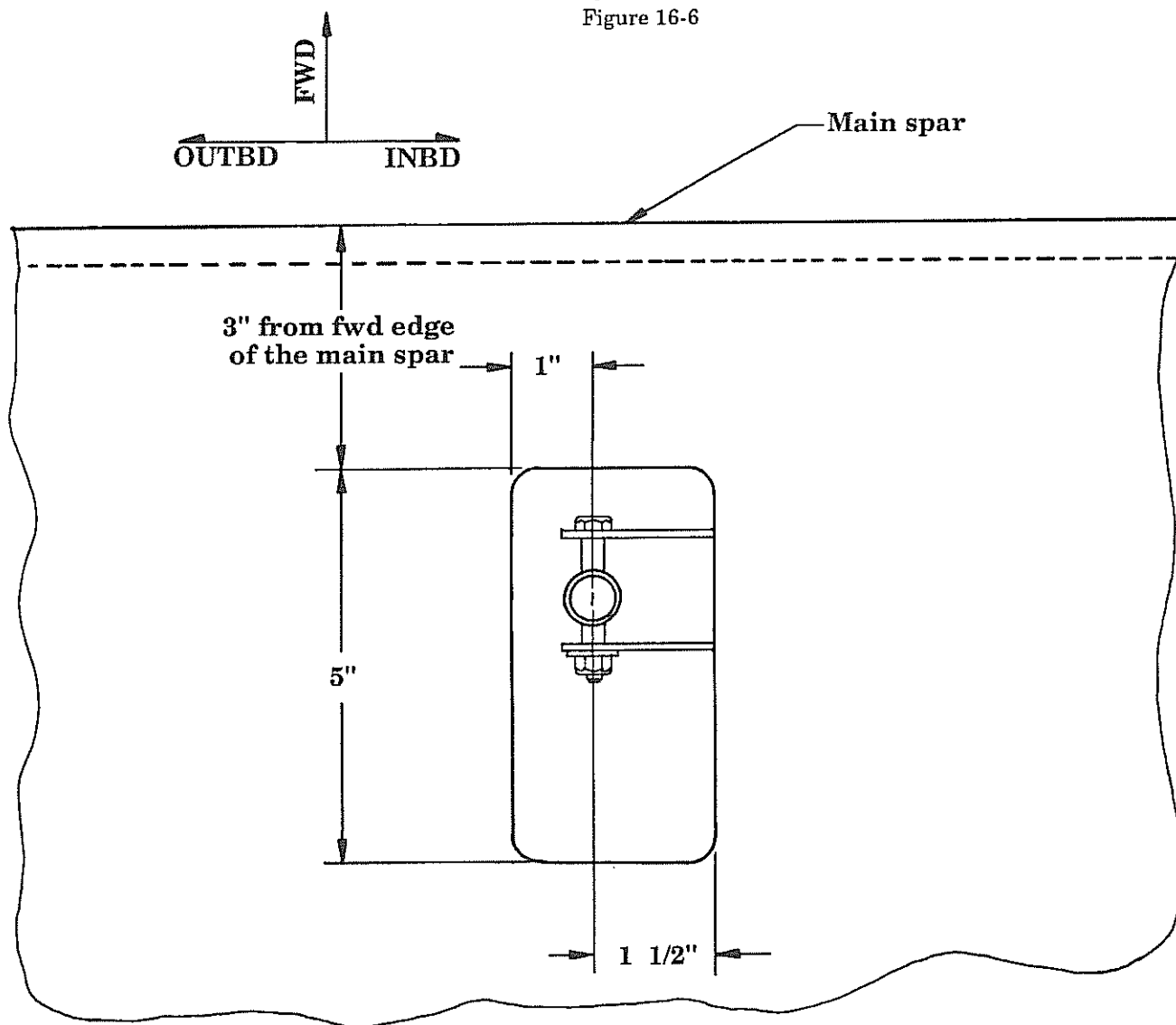

8. Place the seat pan in position and lay some weights on it to hold that position.
9. Apply a 3 BID layup across the fwd edge per figure 16-5. This will form a retention lip for the front of the seat pan. This BID layup should contact approximately 1-1.5" onto the spar and roll up over the seat pan L.E. by about 3/4". Allow to fully cure then remove the seat pan and trim the resultant retaining flange to size. This will form a fwd stop for the seat pan. An aft stop is not required.

C. Flap push rod closeout panel for seat

The flap push rods will require a simple flap panel that isolates them from the cockpit area and also provides a lower seat back panel.

1. Make a 1/4" foam panel with 2 BID on the outer side. It is generally easiest to simply use the plain, white foam material for this part since it requires some slight contouring on the back side for additional push rod clearance.

This panel should fit against the top spar cap / seat back and angle fwd to the floor panel. It should be angled fwd and positioned high enough on the seat back so as to provide positive clearance from the flap push rods during all ranges of motion. This area will be quite heavily padded with upholstery so a real smooth fit will not be required at all.

2. With this panel fitted and glassed with 2 BID on the outer side, remove it and sand the core material back to form additional clearance room where the flap push rod tubes will pass. Sand only about half of the foam core away through this central area thus leaving 1/8" of core. With this area sanded, add a 1 BID ply over it and establish a glass to glass bond on the top and bottom. See figure 16-7.
3. Wrap these pieces with plastic tape on the lower surfaces and position in the plane. Apply a small 3 BID strip along the junction of floor and panel that attaches permanently to the floor and forms a custom lip against the panel.
4. After cure, it is advisable to install one MS24694-S5 machine screw or an AN525 machine screw with one K1000-08 anchor nut to prevent the panel from possibly riding up and out of the retaining flange. See figure 16-7.

SEAT CLOSE OUT PANEL

SIDE VIEW

Figure 16-7

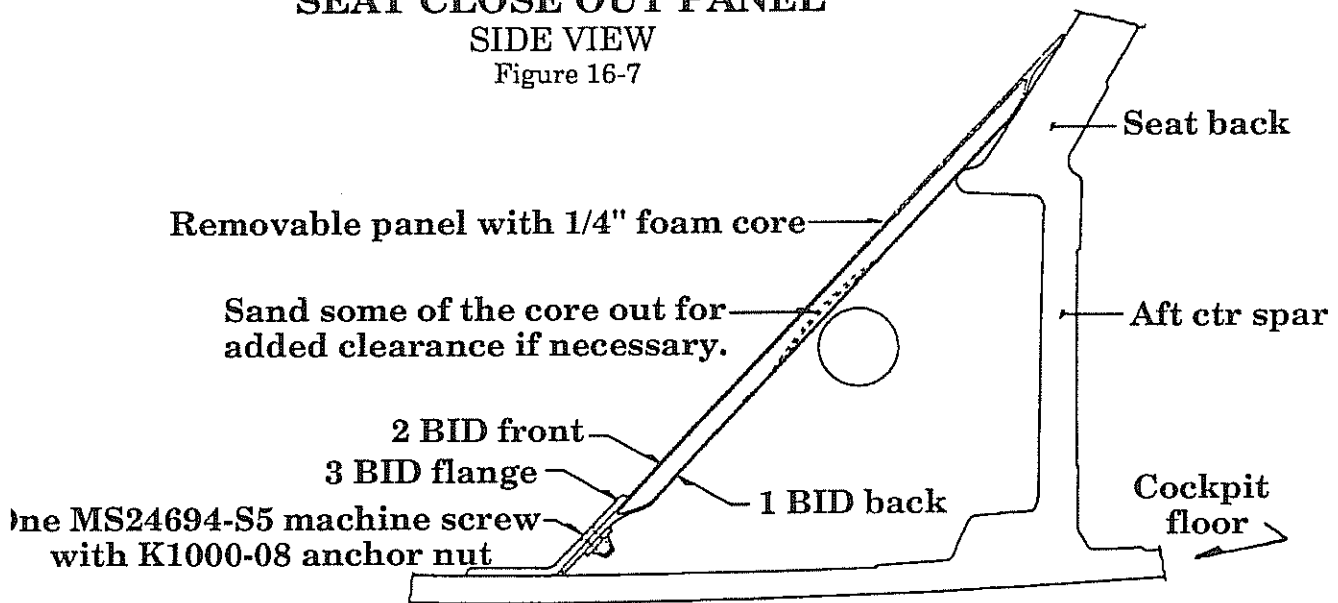

D. Instrument panel installation

The instrument panel is generally fiberglassed into the fslg however it is not a structural bulkhead. Its position should be determined with respect to comfort and instrument room fwd of the panel.

INSTRUMENT PANEL

Figure 16-8

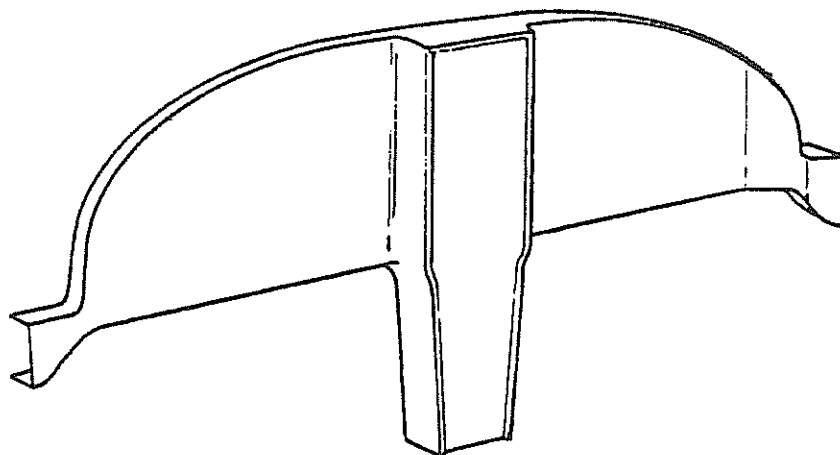

If you are installing our optional pre-molded instrument panel then the dimensions suggested will generally work well and the upper contours, when located off the top longeron, will easily fit under the canopy frame. If you are making your own instrument panel, it is recommended that you first simply lay the canopy frame over the aircraft in its approximate position. This will provide adequate contour information to allow you to check for necessary clearances between instrument panel and canopy frame. It is also possible to first install the canopy and frame prior to permanently installing the instrument panel, see chapter 17 "Canopy Installations". Either approach is acceptable.

1. The optional pre-molded instrument panel is designed to optimize all possible conditions and from all reports, it is well received. A simplified panel will be outlined below and can be easily fabricated. See figure 16-9.
2. The fwd / aft location for the instrument panel is dictated by several concerns. You should sit in the cockpit and feel comfortable with the location with regards to arms reach, knee room, etc. Also, the radio stack will require a minimum of 13" for most standard avionics however some radios and auto pilot boxes are as much as 14" deep. And thirdly, the upper left side of the panel will require careful attention regarding available depth due to the canopy slope.

- If you are fabricating your own panel, it is recommended that you follow the suggested dimensioning and make a pattern that is sawed out of a piece of 3/4" particle board or equiv. You can trial fit this pattern into position. Cover the pattern with plastic tape and apply a 5 BID layup over it. The BID should roll over the edge and extend the full 3/4" to form a stiffening lip around its perimeter. Arrange the BID in all slightly different weave orientations so as to aid in overall stiffness. See figure 16-9.

WOOD INSTRUMENT PANEL PATTERN
LAYOUT SIMILAR TO THE OPTIONAL PRE-MOLDED PANEL

Figure 16-9

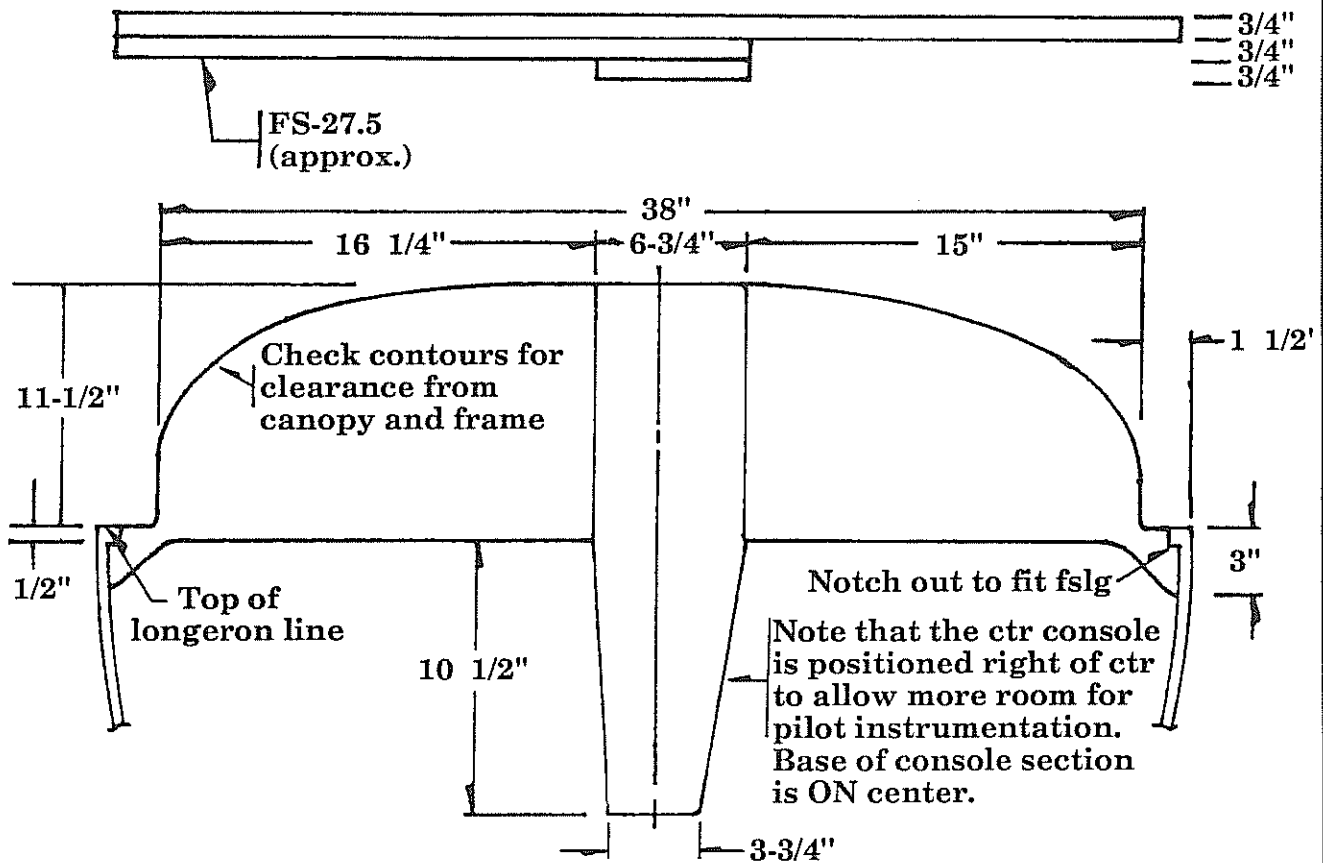

- Fit the panel into the fslg. The lower center portion of the vertical console should rest on the top of the spar cap. The console sides will later be installed up to this vertical console.



5. There is generally a little extra width to the pre-molded panels. This will allow for trimming to fit against the longerons. The panel can be notched to fit against the longerons. The outbd sides of the panel have a horizontal portion that can be aligned to the top of the longerons. This is acceptable however if knee room permits, a slightly lowered panel will afford better gyro installation room. Be sure to allow for upholstery thicknesses when making determinations for the vertical height of the instrument panel and the resultant knee room.

One of the nice advantages of the Lancair cockpit is the leg positions available. We like to fly with our feet back and resting against the angled portion of the sub floor. This will obviously require the ability to rotate your knees up and past the panel bottom so do leave room for that movement.

6. Also a slight lean will provide additional room for long gyros, etc., 2° - 3° is generally acceptable.

7. With the panel location selected, attach it with 3 BID tapes on both left and right fslg sides (fwd and aft faces of the panel) and at the bottom center onto the spar cap with similar 3 BID tapes. Sand the primer coat off the pre-molded panel prior to attaching the BID tapes.

8. When it comes time to start installing instruments, etc., a standard aluminum type hole punch will work for the standard sized instrument holes. We've used the type that have a 5/8" center arbor bolt with a matched die punch plate that fits in the front and back. You then use two big wrenches to tighten the nut on the 5/8" bolt and punch the hole through. This will be considerably harder than with a conventional aluminum panel but it works satisfactorily. Use a drill and / or a rotary tool cutter for the other cut outs.

The cone shaped multiple diameter drill bits (Unibit) work extremely well in producing beautiful smooth holes.

9. The gyro side of the instrument panel requires a small brace to support the panel face due to the weight and length of the gyros. This can be a thin wall steel tube (5/16" diameter) that is flattened out on the ends and then bent to the required contour to fit under the dust cover. Secure the brace with a pop rivet at the instrument panel and either 2 pop rivets or small machine screws at the lip of the fwd deck. The radio stack will also require supports on each side of it that attach to the sides of the nose gear tunnel, these will add additional rigidity. The right hand side of the panel usually does not require any supports.



10. An additional means of supporting the radio boxes at the panel face is to make two small phenolic blocks that will fit between the box sides and the inside of the panel itself (pre-molded panel). Drill and tap the phenolic pieces for 6-32 flat head machine screws. These pieces will only be about 3/16" thick so you'll need very short screws. Screw the phenolic pieces to the radio box, add some epoxy / floc to the mating surfaces and place the radio box unit into position to cure. After cure, simply remove the screws and the phenolic pieces will be bonded into perfect position. This will anchor the front of the radio stack nicely to the instrument panel. The radio boxes should all be screwed or riveted together to form a single unit, this can be accomplished by attaching a simple strap along each side of the radio box stack. (Most radio boxes have provided room for such screw attachments at the panel face areas.) See figure 16-10.

**RADIO BOX SUPPORT
CUT AWAY VIEW**

Figure 16-10

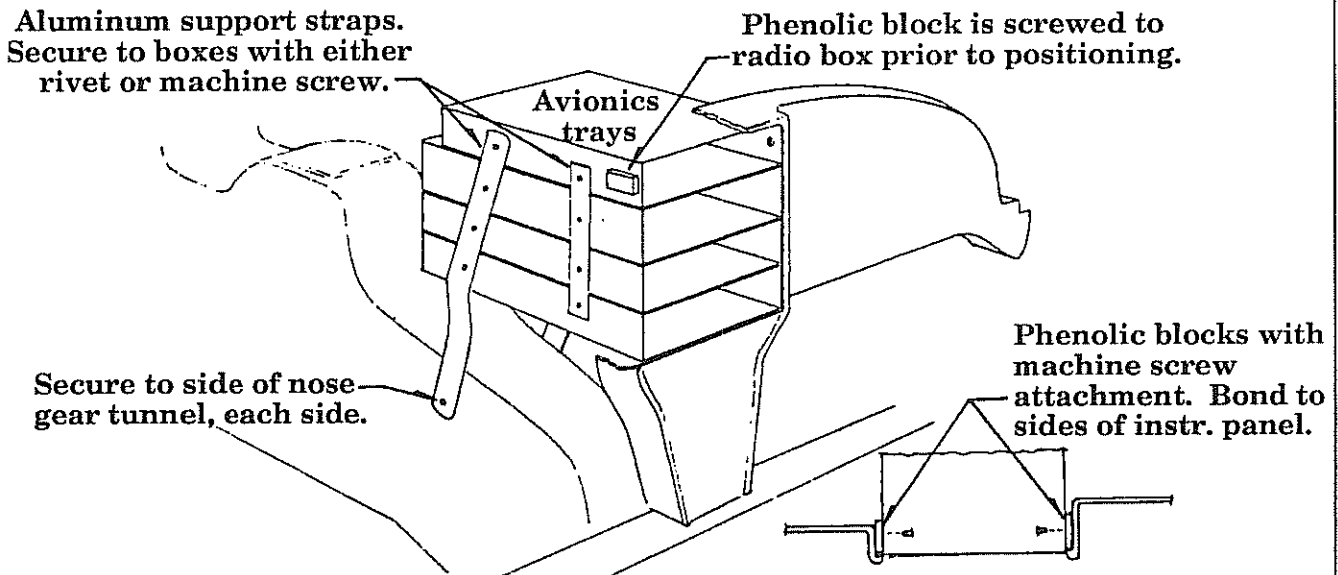

Center console installations

There are two basic installations involved with the center console:

1. Inboard seat belt attachments,
2. Pitch trim installation.

In addition we suggest a center glove box since there is available room and it's nice to have a place for storage of pens, scales, tie downs, flash lights, etc.

CENTER CONSOLE

3/4 VIEW, OVERALL

Figure 16-11

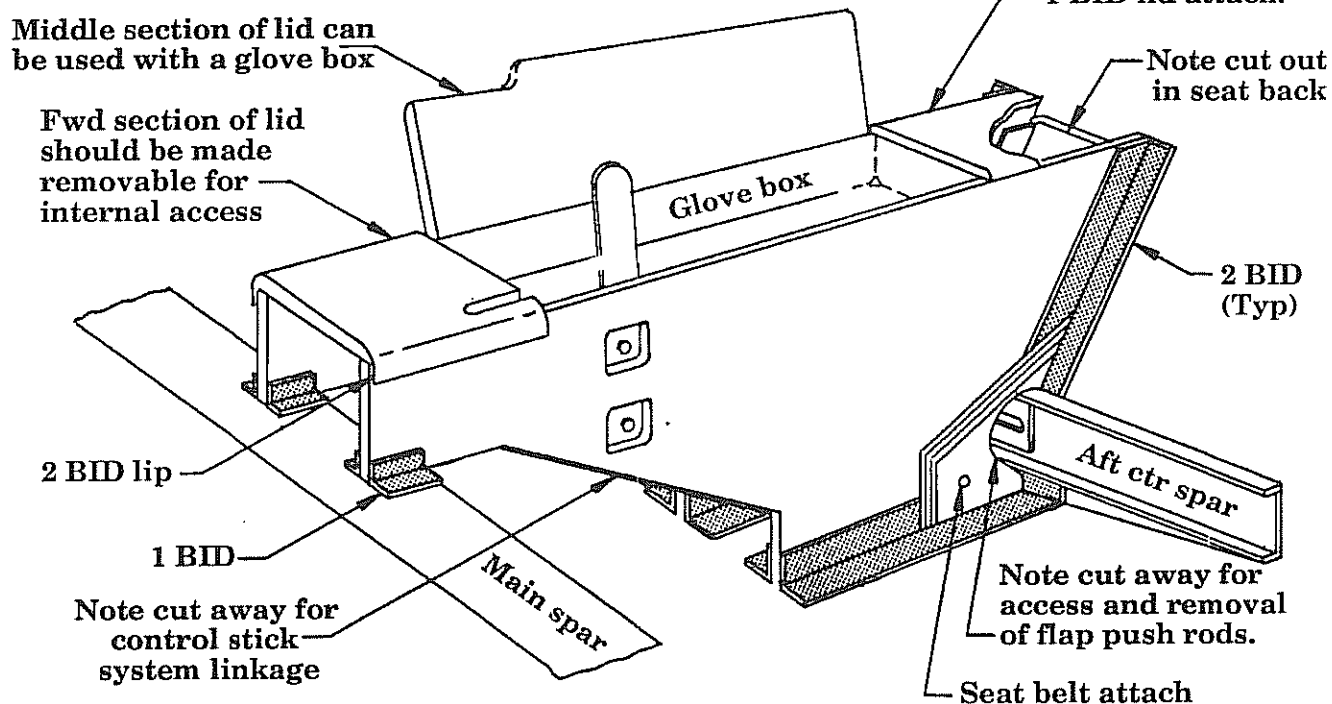

E. Center console positioning & seat belt attach point

The position will allow for your individual comfort. We generally suggest that the console have a narrow aft section which provides for more seat width. And a fwd width such that it blends into the vertical component of the instrument panel.

1. Select a vertical height for the console sides by sitting in the cockpit with approximately the amount of upholstery that will be used. You'll want to sit fairly close to the top of the canopy for the best visibility. This can be estimated with some accuracy by simply placing the canopy frame on the plane in approximate position and having someone carefully lay the canopy on top of it while you sit inside. (You can also install the canopy frame and canopy first, see chapter 17.)

2. We selected a maximum height of 11" for our center console and it seems comfortable. You may want to simply use that dimension.
3. See Blueprint "M" for the full size console pattern. Make this out of cardboard and fit it to your airframe and seat back angle. When completed, make the two sides out of 1/4" core with 1 BID per side. Insert the three 1/4" phenolic hard points into the left side and the one hard point into the right side panel per blueprint "M", see figure 16-12.

CENTER CONSOLE
 SIDE VIEW, ALSO SEE BLUEPRINT "M"
 Figure 16-12

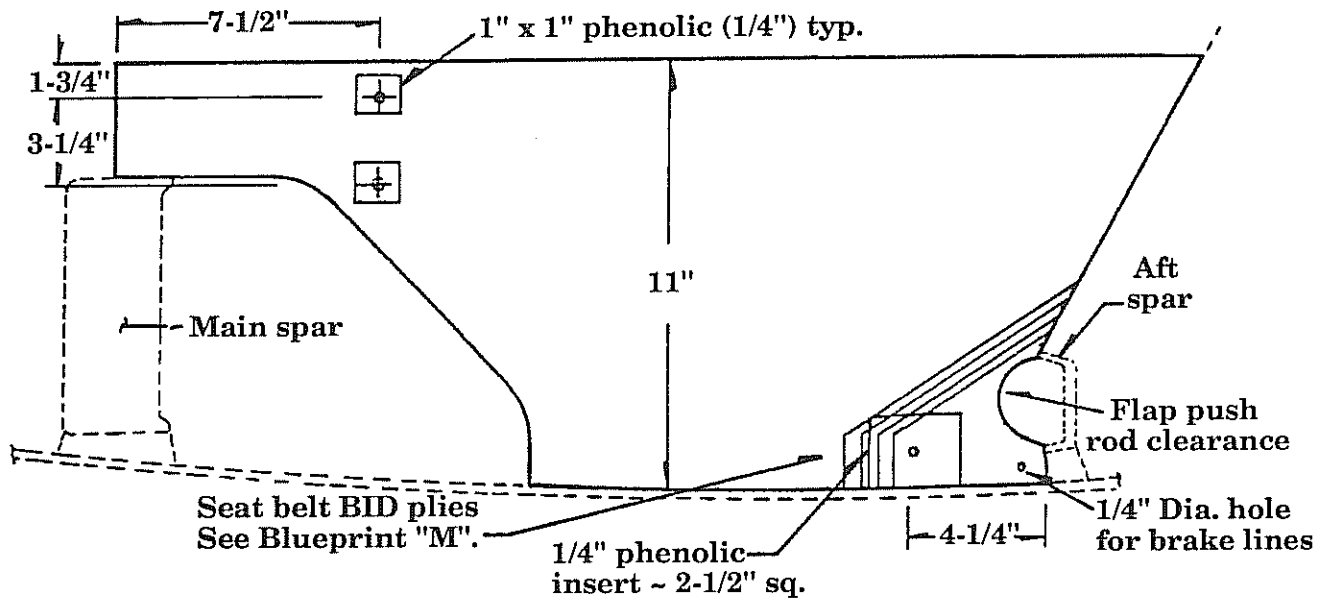

4. The two phenolic hard points for the seat belt attach are typical installations and can be inserted from either side of the panels.
5. The two phenolic hard points for the pitch trim system are unique in their installation. First locate their positions on the inside surface of the left panel.
6. Next attach them with a little epoxy / flox around their edges only. Then apply a 2 BID patch over them, contact at least 1" all around onto the inner surfaces of the panel. Allow to cure.

Lancair International Inc. Copyright © 1991, Redmond, OR 97756

7. Next use a matt knife to carefully cut the core material away from the outside surface and form a smooth bevel that transitions down to the surface of the phenolic that has been attached. Close this out now with a 2 BID patch that lays down into the cut outs. This will provide a recess for the bolt heads on the outside of the console side, see figure 16-13.

ELEVATOR TRIM ARM ATTACH CROSS SECTIONAL VIEW

Figure 16-13

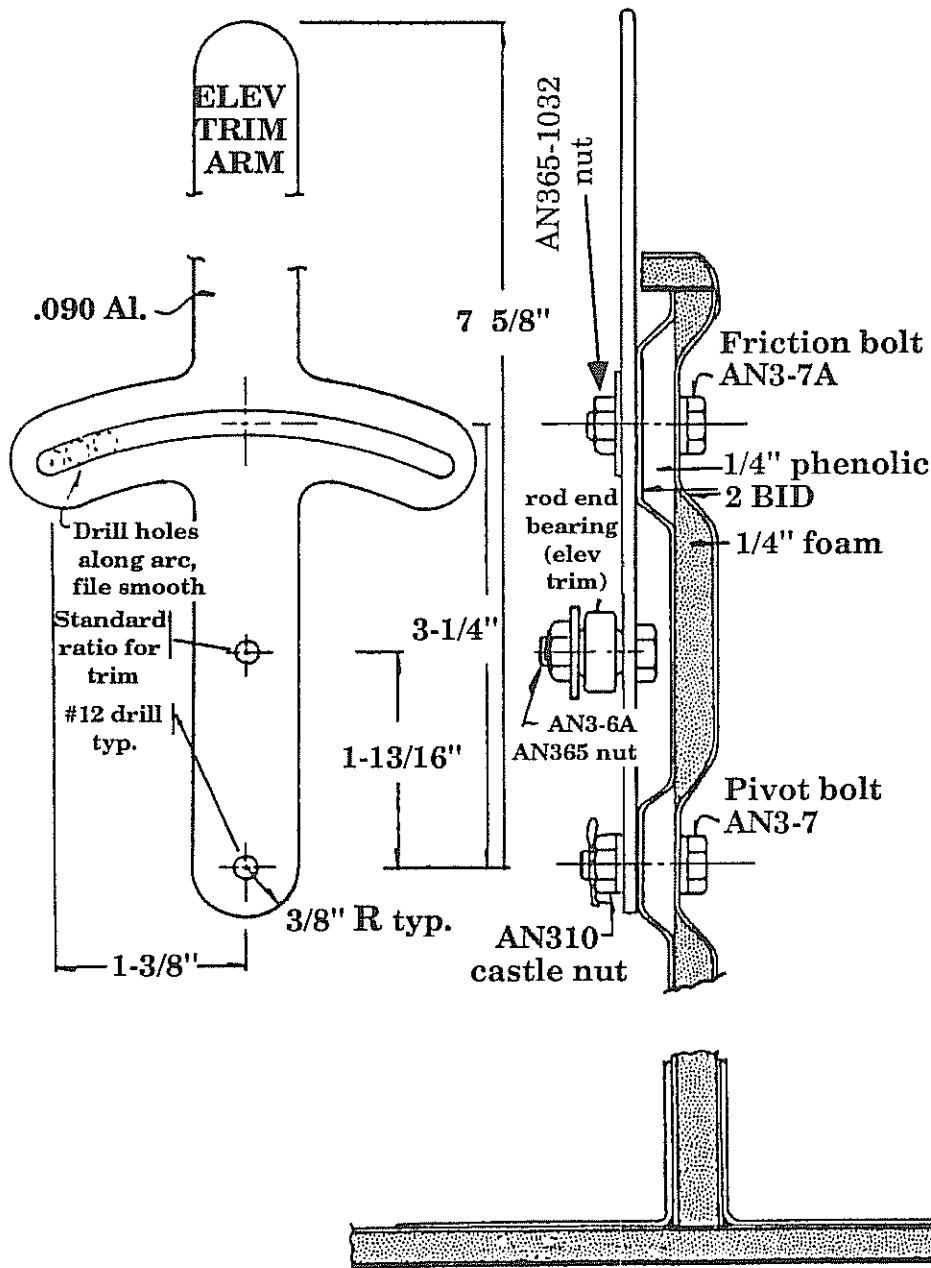

NOTE: When establishing the width of the console, be sure to leave enough room for the elevator pitch trim system installation, see figure 16-17. This will generally require 7/8" minimum clearance from the inner left side wall to the edge of the elevator push rod tube as measured at its widest point on the radius.

8. Make a final fit of the console sides into the cockpit. Mark the top of the console at the instrument panel (fwd end) and at the seat back (aft end).
9. Trim out the center portion of the instrument panel that lays between the two console sides, see figure 16-14. This is a good location to run wires through so you'll want the access. You can also trim the seat back panel to the top of the console sides if desired, but that's not essential. The seat back should however be trimmed so that its cut out aligns with the inner surfaces of the console sides. This will make the application of a bonding BID tape much "cleaner" and easier.

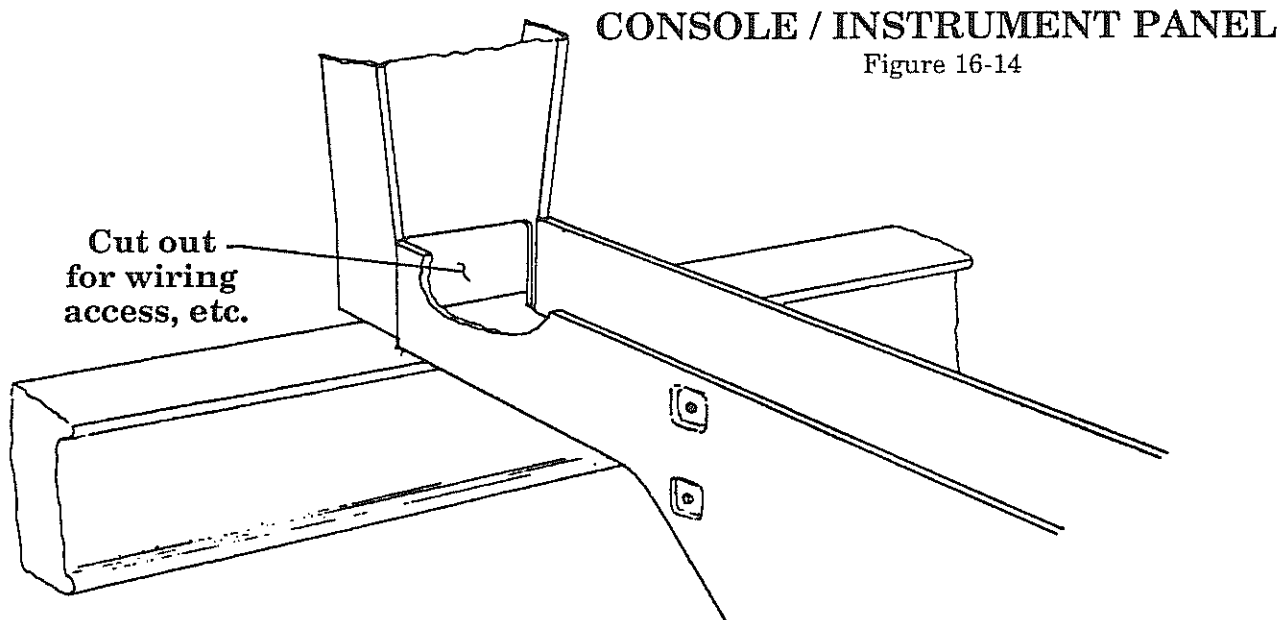

10. Now bond the center console into permanent position using micro / epoxy to pot it in position. Allow to cure.

NOTE: The phenolic pieces for the seat belt attachment should be potted into position but no additional BID tapes should be applied until after the console is bonded into position in the cockpit.

11. See figures 16-11 and 16-15 for the attach BID schedules of the console sides. Add the 2 BID around the entire perimeter on both the inside and the outside surfaces.

CONSOLE / SEAT BELT ATTACHMENT CROSS SECTIONAL VIEW

Figure 16-15

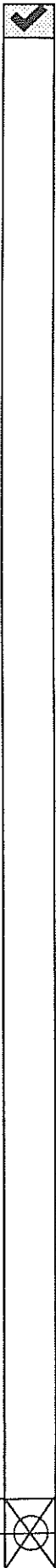
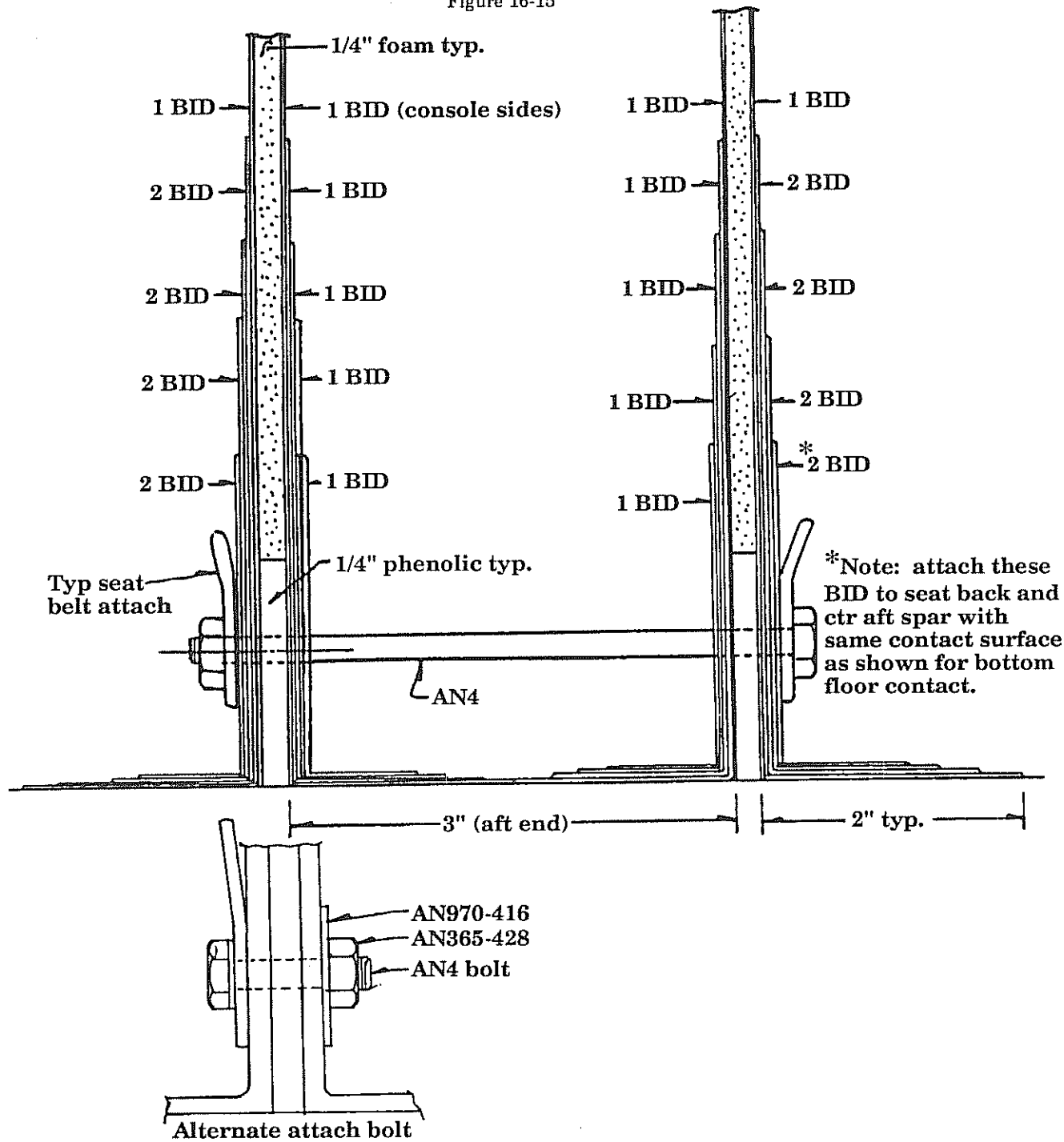

12. Add the additional BID schedules along the aft floor and against the aft spar web which will create the seat belt hard point. This additional (and quite substantial) BID ply schedule can be added immediately after the initial 2 BID are applied. In fact it's a good idea to do that all at one time rather than allow the 2 BID to cure first.
 You'll find it easiest to make a slit in the BID plies where they fit into the corner formed by the floor, console and aft spar web. See Blueprint "M".
13. When cured, drill the 1/4" hole for the seat belt attachment bolt. It is recommended that one through bolt be used instead of two smaller bolts. This has a structural advantage of reducing the bending moment on the bolt. This will require hole alignment from left to right side when drilling. Use a long 1/4" drill bit to achieve the alignment. Since the console width dimensions will vary from one builder to another, we are unable to supply this through bolt in standard airframe kits. If you use two smaller bolts, be sure to install an AN970-4 area washer between the bolts and the inner sides of the console sides. See figure 16-15.
14. Make a console top from 1/4" foam with 1 BID per side. Make a one piece console top to begin with. This top can then be cut into three segments. See figure 16-16. The aft segment should be bonded permanently to the console sides and seat back. Use 1 BID to make this attachment.

CONSOLE TOP

Figure 16-16

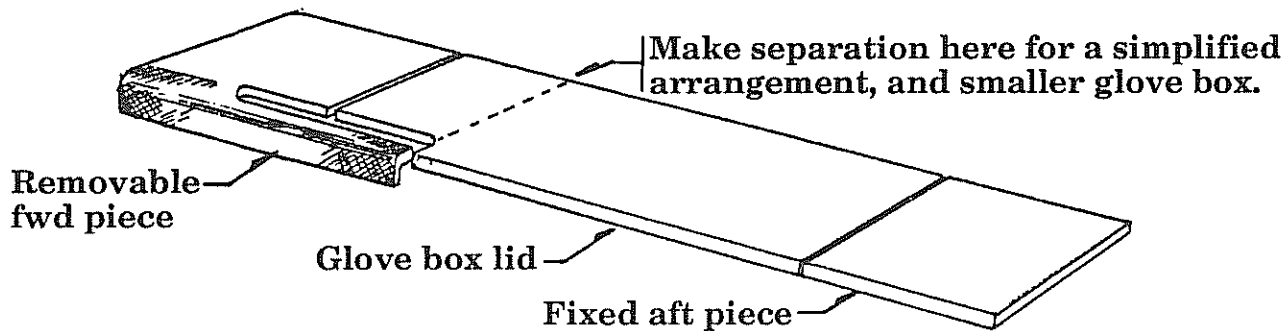

15. The middle portion can be made as a glove box lid, see section "H" in this chapter, "Console glove box installation".

16. The fwd portion of the console top should measure approximately 4" to 6" in length and should be made removable. To accomplish this, place plastic tape on the outer sides of the console and position the fwd top piece. Lay a 2 BID ply over the edges and extend them down about 1/2-3/4" past the top of the sides. Allow to cure. This will form a custom "lip" which will hold the part in position. It will require a slot cut into it for movement of the pitch trim handle but that can be done later as required for clearance. You'll want to be able to remove this panel for access to controls and wiring.



F. Pitch trim installation

The pitch trim system is a very simple and effective spring loaded unit. Some builders have installed an electric servo system to drive it, but we prefer the simple mechanical arm.

1. Make the control arm per figure 16-13. (This is supplied in the Builder Hardware Options Kit.)
2. Next select the nylon attach block and saw it in half as shown in figure 16-17. This will allow positioning onto the fwd push rod of the elevator linkage.
3. Assemble the spring rod per figure 16-18. This will require cutting the spring into two equal length pieces. Drill and tap one end only for the M34-14 rod end bearing. Use the washer and cotter key to "set" the springs properly onto the shaft.

NOTE: It is generally best to make a quick "fit check" of the installation into the console. If space allows, it is then best to position the springs & nylon block at the extreme opposite end of the rod end bearing. This will help with alignments throughout the small rotational arc created when the control arm is pushed from fwd to aft.

4. Mount the assembly onto the fwd elevator push rod using the two AN3-17A bolts and AN365-1032 lock nuts.

WARNING: Do not overtighten the bolts that mount the nylon block. The block should only be tightened enough to firmly set the block in position. Over tightening could break the nylon block thus loosening all pitch trim.



ELEVATOR PITCH TRIM

Figure 16-17

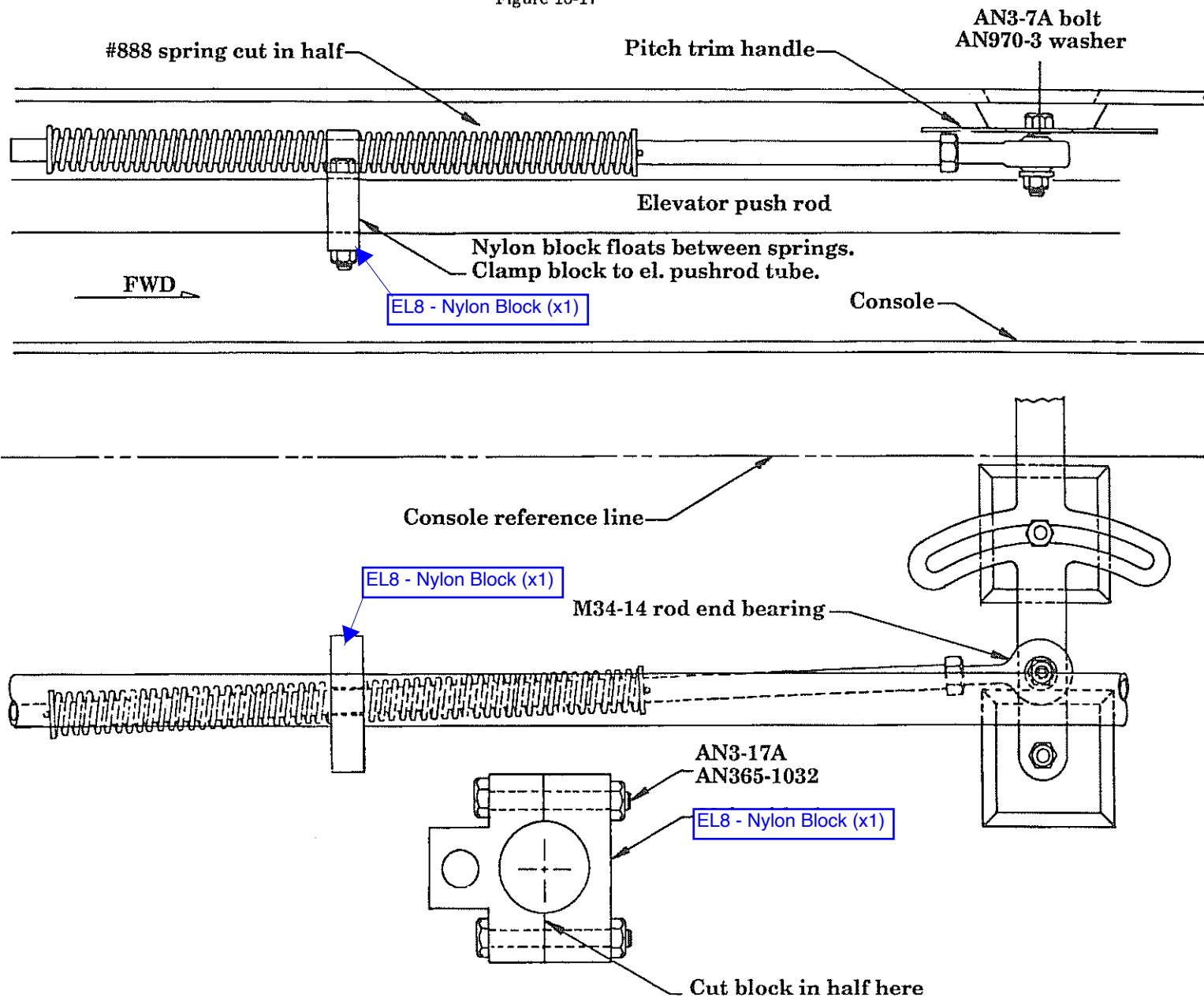

ELEVATOR PITCH TRIM BREAKDOWN DRAWING

Figure 16-18

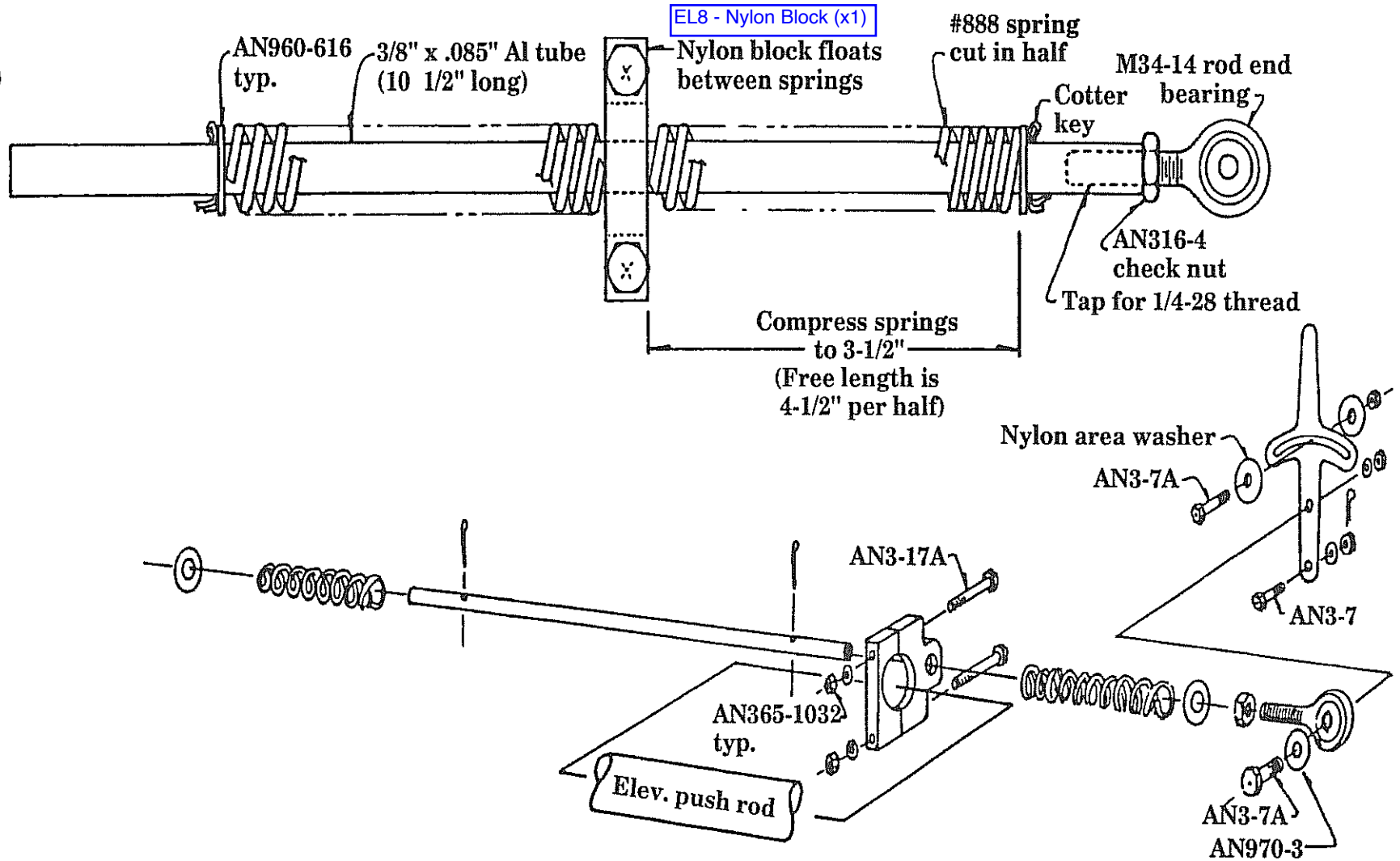



G. Pitch trim adjustments

1. The final adjustment of the trim system will be made based on flight conditions. However, as a preliminary position, set the spring assembly on the push rod such that when the trim arm is vertical, the elevator is slightly T.E. UP. (I.e., about 3-5° up elevator with the trim arm vertical in the cockpit.) This will be a good starting position.

When properly positioned, there should be sufficient travel to trim the plane in all flight conditions. Small adjustments can be made by simply sliding the nylon block fwd or aft on the elevator push rod. Make very small adjustments, a 1/8" position change of the nylon block on the push rod will have very significant results.

2. Also check the rotational position of the nylon block and the connected spring assembly. By rotating the nylon block slightly up or down (around the push rod), the assembly can be set into position that is most favorable for a smooth operation.
3. Set the tension on the two bolts that hold the control arm such that it moves smoothly but with considerable resistance. The two nylon area washers should be spaced on either side of the top "tension" bolt. To check the tension, set what you think is correct and then move the control stick through about 60% of it's full travel motion. The trim arm should not move. If you set it at an elevator neutral position, you should be able to pull about 3/4 of the elevator up motion without moving the trim arm at all. If you can pull full up elevator, then that's better yet. If you get a little movement of the trim arm with extreme up elevator, then that is generally acceptable as well. Normal flight conditions will not see that kind of travel extreme from a trimmed position and if it did occur, you would simply pull the trim arm slightly which would not cause any problems other than requiring a re-trim however if it resulted in a sharp snap movement of the stick then adjustments must be made to avoid such a condition as it would be detrimental to smooth, safe flight.



H. Console glove box (optional installation)

As mentioned previously, you do not have to install a glove box but the Lancair does have room for one and they're real handy to have.

1. With the location of the glove box selected, you should already have the part that will form the lid. See section "E" of this chapter. (After you have completed this installation, go back and fill the perimeter of the lid with epoxy / micro to close out the bare foam edges.)
2. It is perhaps easiest to make a "plug" of the actual cavity that you have chosen to become the glove box tray. This can be made from a piece of wood which has been covered with plastic tape as a release. See figure 16-19.

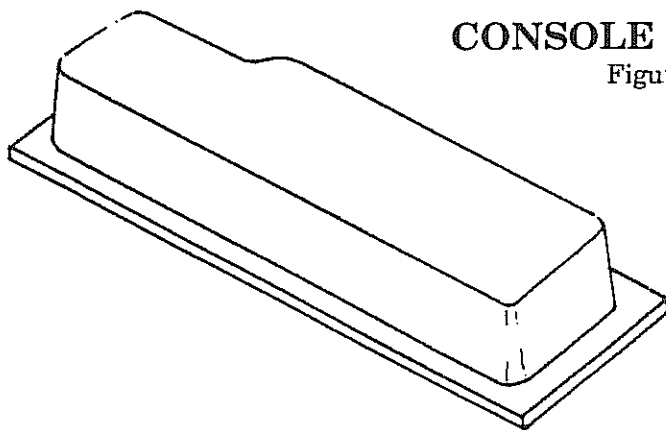

CONSOLE GLOVE BOX

Figure 16-19

The glove box "plug" should be made smaller than the inside width of the box by about $\frac{3}{16}$ ". This will allow for the thickness of the BID and a little clearance room.

Calculate the available depth of the box so that it will not hit any of the controls. Also note that a "jog" will be required at the left, fwd end where clearance from the pitch trim arm will be required.

3. With the plug covered with plastic tape, lay 3 BID over it. Allow the 3 BID to roll out at the base of the plug, this will be the top of the tray and thus form a lip for the tray to hang from. You will later trim the lip to not extend past the outside edges of the console. Allow to cure then lift it off the plug. You now have a custom tray.
4. With the actual tray fitted into the console, cut two small sections of hinge - about 2" long each. Drill several holes into one side of the hinge section only.
5. Scrape away the core in the lid where the hinge pieces can be pressed in position. Also do the same for a position into the right side of the console side to accept the other hinge halves.

6. Cover the undrilled hinge halves with plastic tape as a release.
7. Fill all four of the slots with epoxy / flox. Press the hinge halves that are drilled with holes, into the top panel and at the same time press the remaining sides that are covered with plastic tape into the console sides. Wiggle it down into a good aligning position, add a couple of weights to hold it in place and let it cure.
 Note that the tray will require a couple of clearance cuts around the areas where the hinges will be positioned.
8. After cure, you can remove the lid by pulling straight up and releasing the hinge "tabs" out of the console sides. This will make removing the console lid easy yet the lid will stay in place quite nicely by slipping into the custom made channels made into the console sides.

GLOVE BOX
CROSS SECTIONAL VIEW
 Figure 16-20

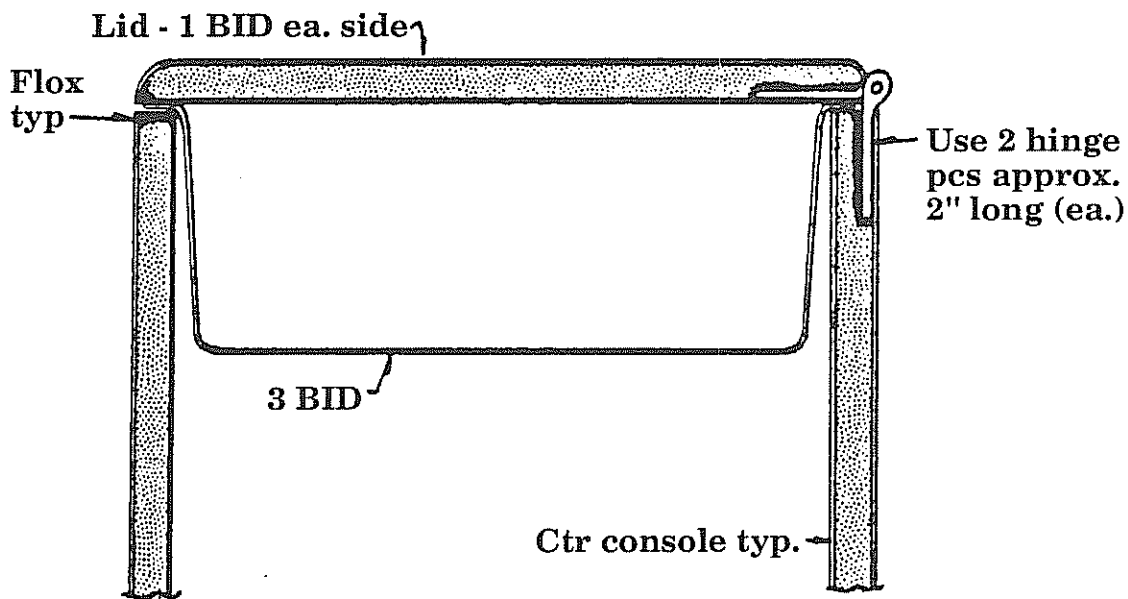

I. Side arm rest installations

Side arm rests are not required but they sure are comfortable and easy to install.

1. First sit in the cockpit with appropriate cushioning to simulate the upholstery and relative seating heights.

Take a book or anything similar and place it under your left elbow to simulate the ideal position for an arm rest. Now hold the control stick and pull it aft noting the angle of movement required of your left elbow. It's not horizontal at all but at an angle of about 15° (being higher in front than in the back).

When it feels about right, mark a pencil line on the side of the fslg to indicate this ideal position and angle of the arm rest. This line will indicate a "top surface" for the arm rest so you must calculate padding and base plate thickness when positioning the actual mounting bracket.

2. There are a lot of acceptable ways to attach an arm rest but probably the easiest and quickest is to simply cut a piece of 1" x 1" angle aluminum about 4" long per side. Drill a bunch of holes into one side for floc and also two small holes for a couple of pop rivets.
3. Put the angle aluminum pieces onto the fslg and set them with the two pop rivets. The pop rivets will simply penetrate the inner skin and core of the fslg, not the outer skin.
4. Make a base plate that can be padded and upholstered. Use a piece of 1/4" plywood for this purpose. Cut it to the size you want the arm rest to be. It should be small so as not to get into your way when entering or exiting. Our arm rest measures 6" long by 1-3/8" wide and it could be somewhat smaller and still be very comfortable.
5. Simply use two small screws, entering from the underside to secure the wood base to the aluminum tab.



SIDE ARM REST

Figure 16-21

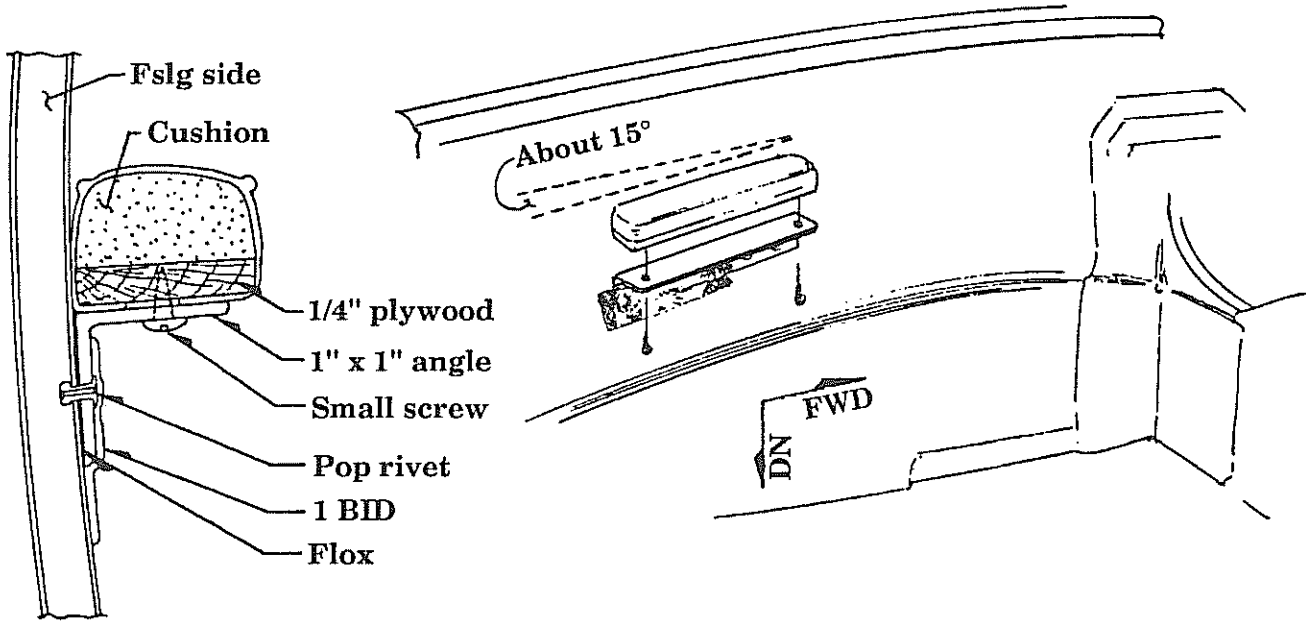

J. Shoulder strap installations

Shoulder straps, though not required are strongly recommended for safety. The "Y" type of shoulder strap is preferred. This type will therefore have less straps transitioning through the baggage area.

1. First make the upper brace for the top of the baggage bulkhead, this is where the shoulder straps will attach. See figure 16-22. Make a cardboard pattern that fits the fslg sides and in a manner similar to that used with the seat back bulkhead, tape the two cardboard sides together to form the accurate length of the upper brace panel.
2. Make the brace from 1/2" foam (or 3/8" honeycomb) with 2 BID per side. Insert the two phenolic pieces where the shoulder strap attach bolts will be located. See figure 16-23.

NOTE: This upper brace can also serve as a "hat shelf", see the suggested installation in figure 16-22. Due to its long moment arm, this area will have to be placarded for 5 lbs maximum (for CG reasons). Also check your particular weight and balance for accurate data on your aircraft.

SHOULDER STRAP ATTACHMENT

Figure 16-22

Removable panel with vertical member attached

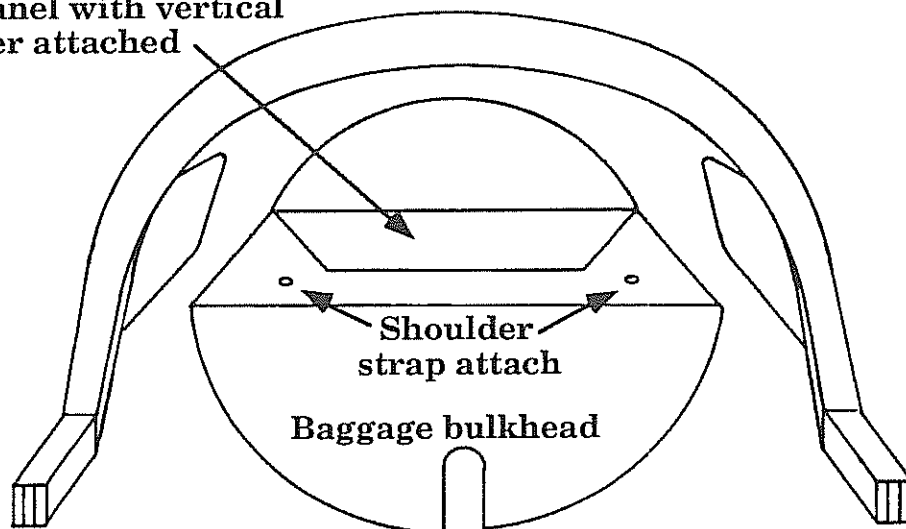

SHOULDER STRAP ATTACHMENT

Figure 16-23

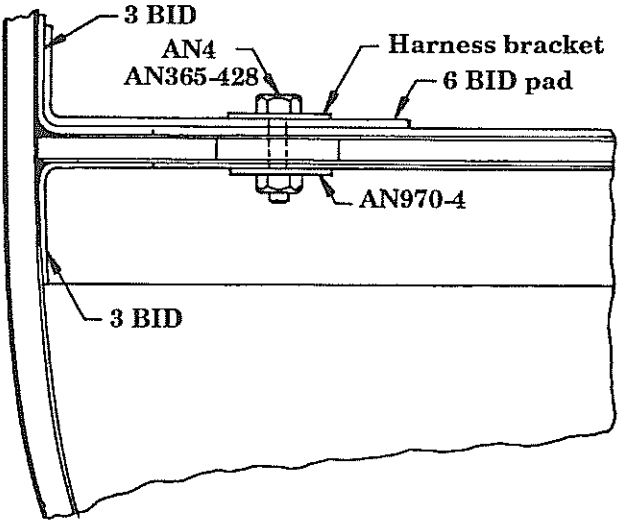
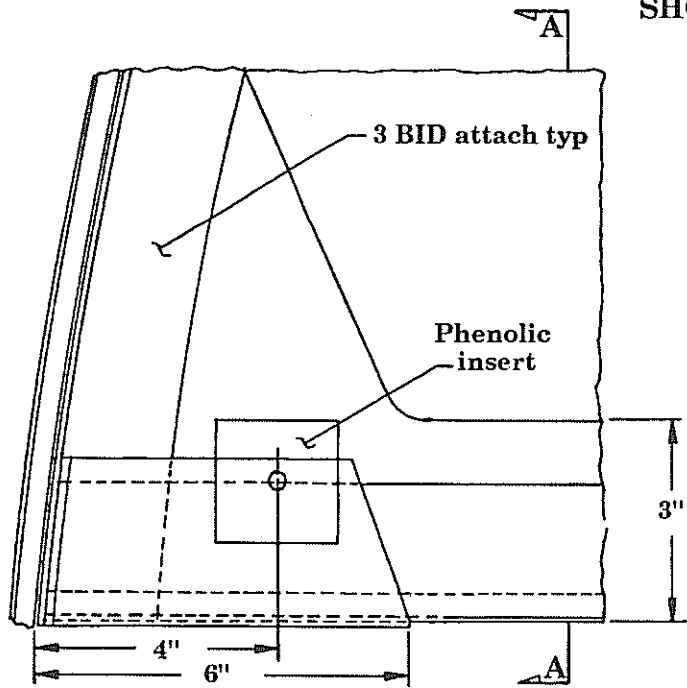

VIEW AA 2 versions

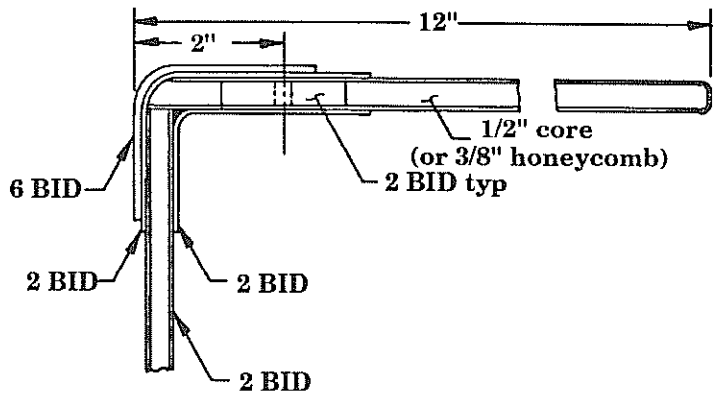
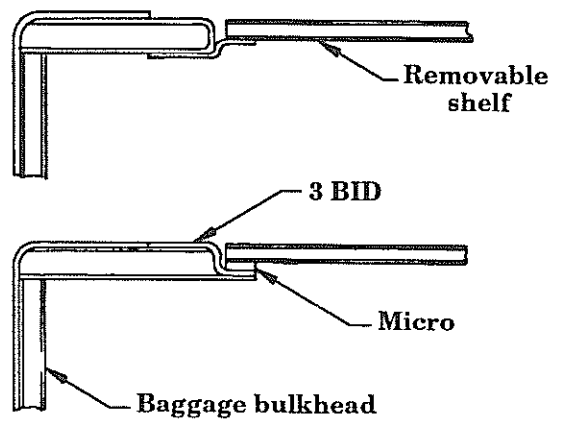

3. Use micro to pot the upper brace into position.
4. Secure it with 3 BID along the fslg sides both upper and lower plus 2 BID across the top of the intersection of baggage bulkhead to upper brace. This 2 BID should be on both fwd and aft sides. And at the same time, add the additional plies where the shoulder strap hard points are located, see figure 16-23.
5. Figure 16-23 shows two acceptable ways to fit a removable center portion which will complete the "hat shelf".
6. The hat shelf itself can be simply 1 BID over 1/4" foam. At the back edge, make a vertical bulkhead closeout to seal off the tail cone from the cabin area. This will also be simply a 1 BID layup over 1/4" foam core.
7. For removal of the vertical bulkhead, you have to hinge the piece onto the center portion of the hat shelf floor. Use two small 2" hinge sections in a manner similar to that of the glove box lid only permanently bond both sides of the hinges into their respective panels. Place a small tab vertically on the top of the fslg tail cone area so that you can hold the vertical panel up in position with a small velcro attachment from back of panel to the tab on the fslg. The tab can be made of a small 1/2" long 3 BID piece of angle. You may also need a small tab to hold the front of the panel down against the upper brace, use a small (1/2" x 1-1/4") piece of aluminum or a 3 BID piece of glass. Set it with one pop rivet into the fwd 3" wide section of the shoulder strap cross member. Then simply swing it over the front edge of the removable panel to hold the panel front down into its mating lip.



K. NACA duct installations (cockpit ventilation)

Cockpit ventilation is achieved best by installing two NACA ducts into the fslg. Neico Aviation has two popular vents available, see our options catalog. We prefer the simple plenum box NACA ducts as the other type is a bit delicate and do not seem to offer good longevity.

1. The recommended position for the NACA ducts is per figure 16-24. For position, what is important is that when you are seated in the cockpit, you should be able to see the duct under the instrument panel. If you can see it, it can see you (and thus blow air into your face if desired).

NACA DUCT POSITION

Figure 16-24

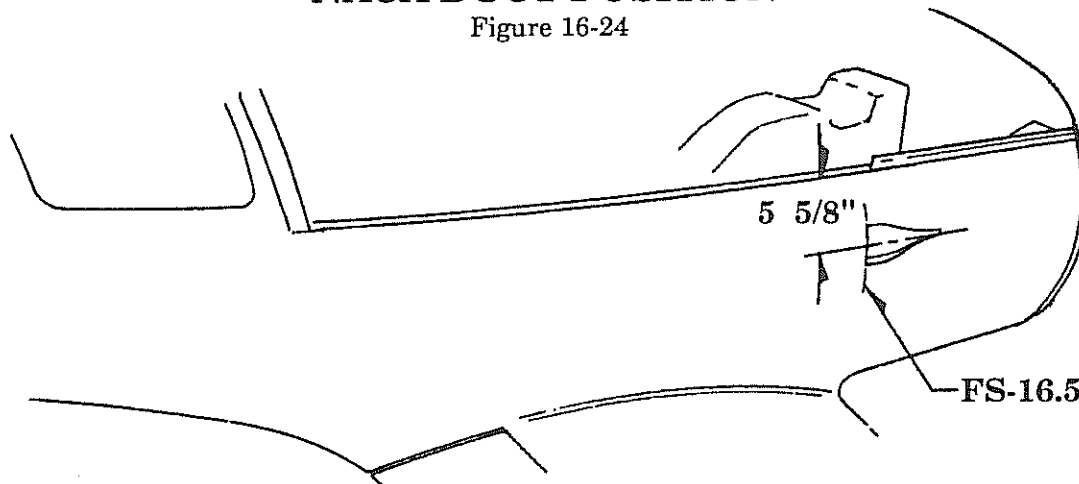

2. Use the full size pattern in figure 16-25 and position it onto the outside of the fslg according to the recommended positioning and also provided that it is in agreement with your particular cockpit orientation as determined by your seating position.
3. Use a sabre saw and cut all the way through the fslg.
4. Next, from the inside, enlarge the cut out so that the actual NACA duct can be bonded in from the inside and contact directly onto the outer skin plies. Leave about a 1/2" lip on the NACA duct itself. Use either epoxy/flox or better yet use structural adhesive to bond the NACA duct into position. Use pop rivets from the outside to hold it tight against the fslg skin when bonding into position. Allow to cure.
5. Next add a micro fillet around the inside against the honeycomb core that is exposed and follow up directly after with 2 BID all around the perimeter. Contact at least 2" onto the fslg and onto as much as possible of the NACA duct (up to about 1-1/2" maximum).

6. Now you can drill and install an eyeball vent or bond a short section of tubing onto the plenum box so as to be able to route a remote vent onto the instrument panel.
7. Neico Aviation has available two types of eyeball vents. One is the screw mount type that can be installed directly onto the plenum box of the NACA duct. The other can be panel mounted since it has a more decorative face panel with a rear attachment bezel. This unit can also be fitted with a custom plenum of its own that allows for a 3/4" hose connection. See the Options Catalog. With this combination, you can install two vents per side by simply attaching a short length of 3/4" tubing onto the top of the plenum box and routing a piece of 3/4" scot hose to the remote panel mounted vent. The lower center portion of the optional Lancair 320 instrument panel has a custom mounting position built into it.

NOTE: It is important to keep the edges of the NACA duct relatively sharp on the outside. This will help generate a vortex that slows the air, thus building pressure and making the duct most effective.

Page 16-39 and 16-40 are identical so that one may be removed and used as a full size template, while retaining manual content.



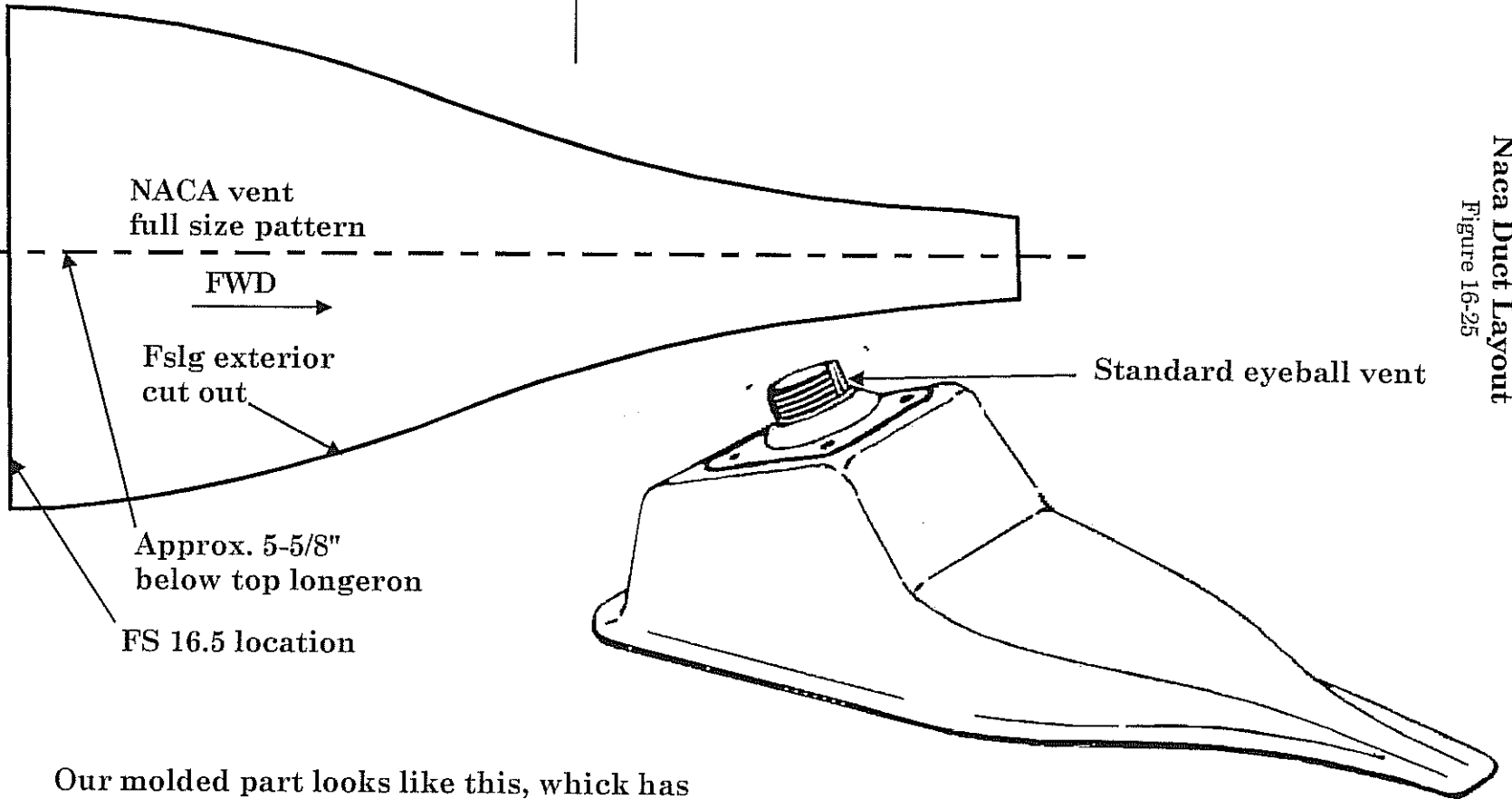
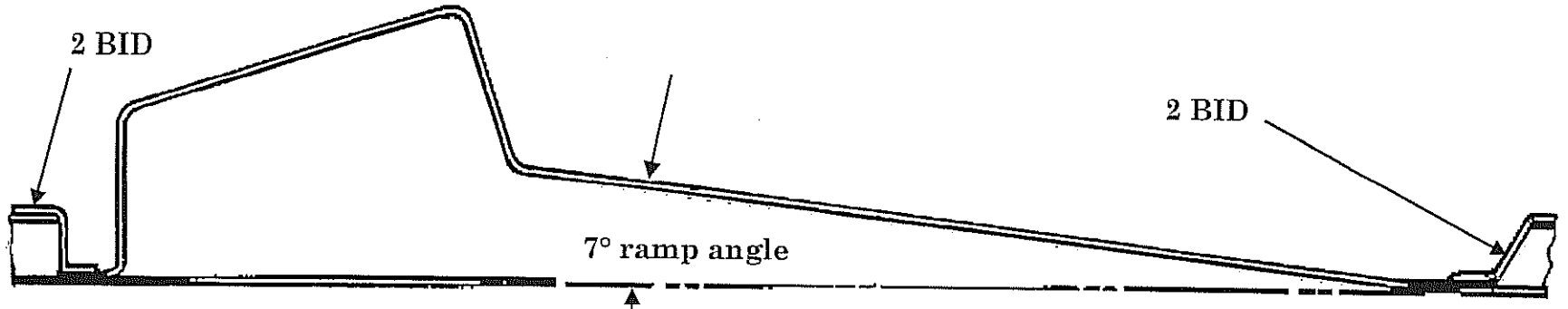

Our molded part looks like this, which has the provision for a direct mounting of the standard eyeball vent, as shown

Naca Duct Layout
Figure 16-25



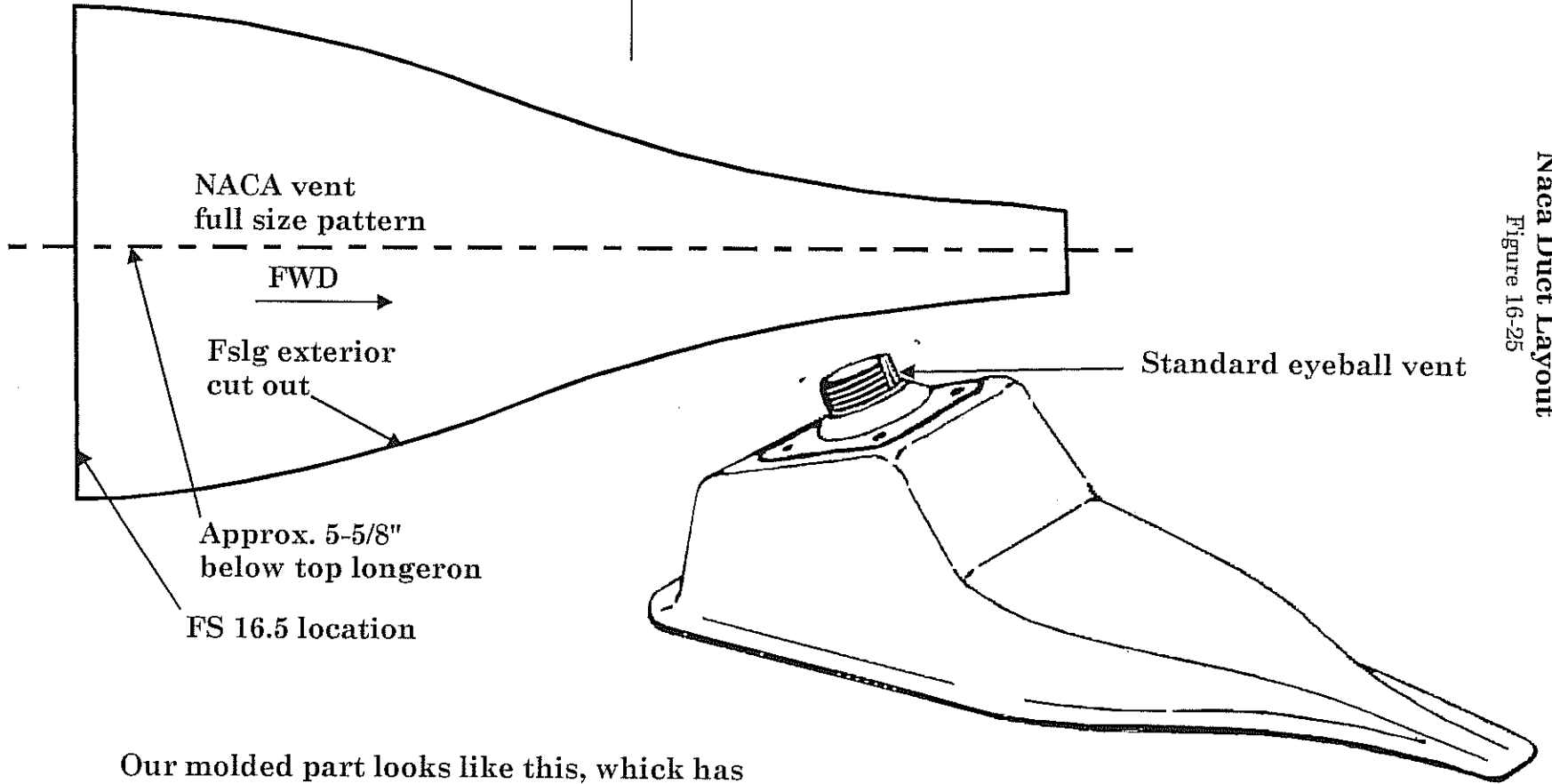
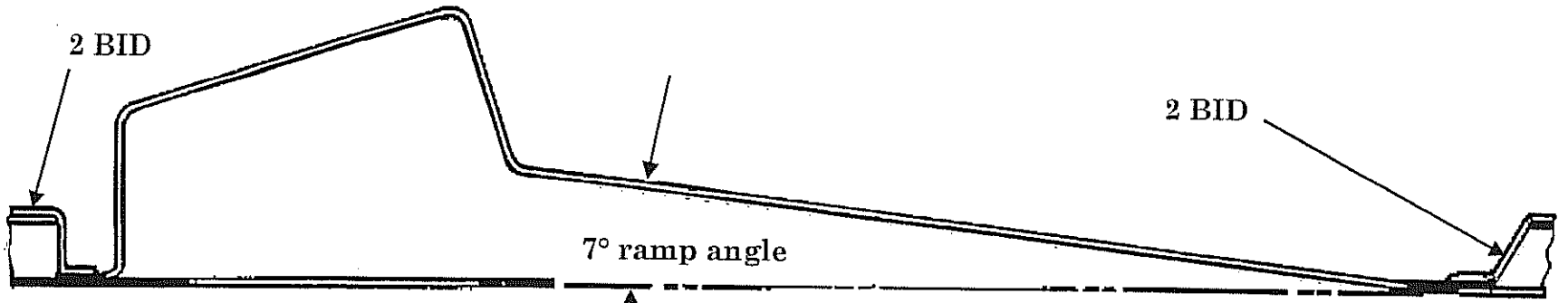

Our molded part looks like this, which has the provision for a direct mounting of the standard eyeball vent, as shown

Nacua Duct Layout
Figure 16-25



Pitot / static installations

There are many acceptable approaches to the installation of the pitot and static system. Much depends on your degree of preferred sophistication and intended flying uses. (I.e., for serious IFR flying you should have a heated pitot tube with alternate static air switching capabilities.) We will show two of the many possible installations.

L. Home made pitot tube installation

1. This installation can be placed just inside of the BL-50 rib thus eliminating a connection with wing removal. It is just marginally outside the prop wash so you will get a little buffet on the airspeed needle when on the ground due to the ground effect. In the air, it works quite satisfactorily. You can however locate this at an outbd wing location and make the connection with wing removal / installation. See figure 16-26.

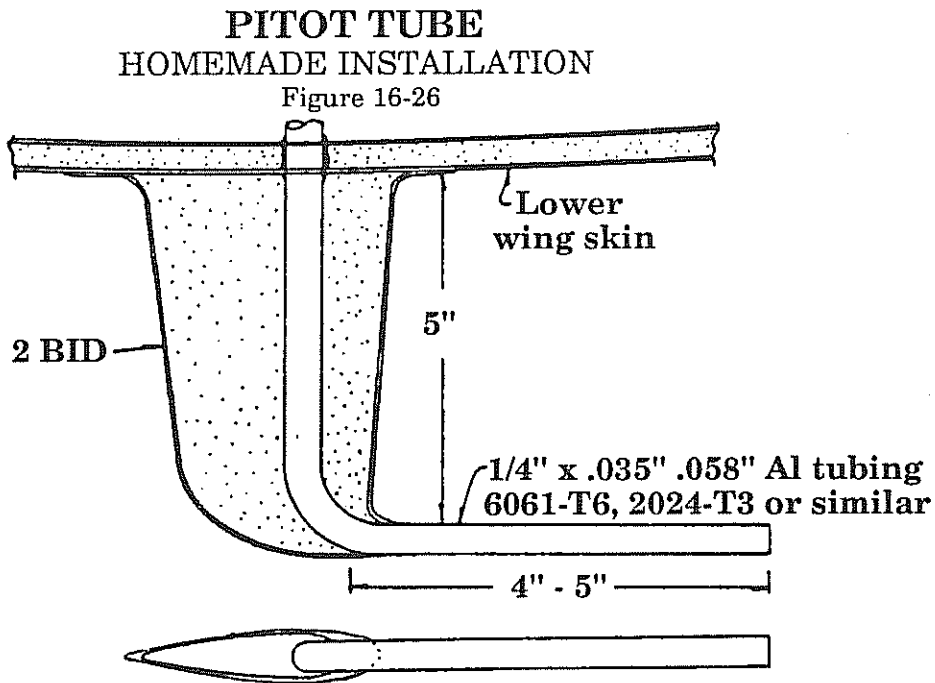

M. AN5812 Standard pitot tube installation

1. A standard heated pitot tube can also be a simple installation and looks perhaps a bit more professional. The AN5812 heated unit is available from a variety of sources (including Neico - be sure to use the correct suffix when ordering - the AN5812-12 is 12 volt, and the AN5812-24 is 24 volt) and can be installed quickly.
2. Cover the base of the unit with wax or plastic tape as a release then take a piece of scrap plywood or equiv. and cut a small hole in it to allow the leads to protrude through.
3. Check the approximate angle of the unit against the lower wing skin and set the plywood such to match that when the unit is placed on top. See figure 16-27. A few dabs of hot or instant glue will hold it in place temporarily. Cover the wood base with release as well.
4. Now lay up a 4 BID piece around the base. Roll up onto the pitot unit about 1/4" past the mounting screw holes. Roll onto the wood base form by about 1". Allow to cure.
5. After cure, pop the base off and pull the pitot unit out of the now formed attach bracket. It will pull out a bit hard, but it WILL pull out.

Trim the bracket and bond it onto the bottom of the wing panel having cut a clearance hole for the pitot unit into the skin. Use epoxy/flox to attach the bracket and fair it in with micro later. Drill through and use the supplied screws to hold the pitot unit into the fiberglass mount.



PITOT TUBE
COMMERCIAL, HEATED TYPE INSTALLATION
Figure 16-27

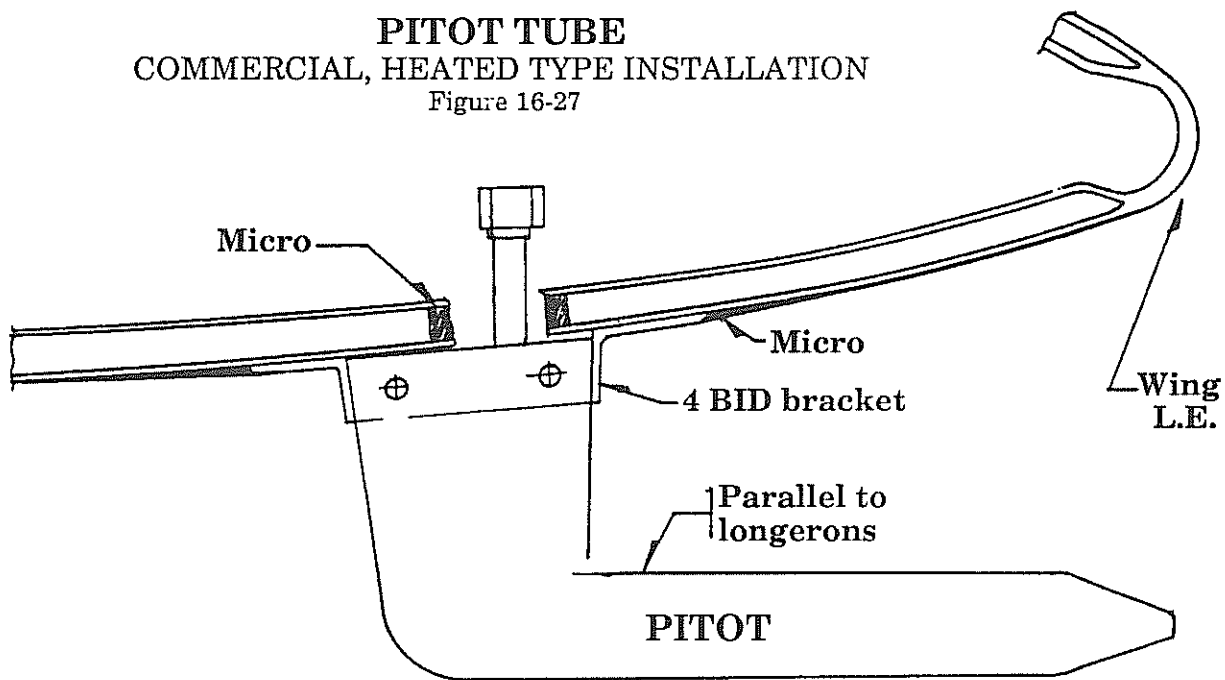

NOTE: The pitot tube should be positioned parallel with the level line of the fslg and just behind the leading edge of the wing.

6. Run a piece of aluminum line from the pitot unit through the D section of the wing into the cockpit and up behind the instrument panel. Secure it at the panel and fslg side with a couple pieces of 1 BID (each about 2" long will be sufficient).

CAUTION: Do not secure this aluminum line (from the pitot tube to back of instrument panel) until the canopy mechanism is installed since you will have to be sure to clear all of that mechanism with the line.

N. Static port installation

1. This static port is the most susceptible to instrument reading errors since it is not easy to accurately locate a position on the side of the fslg that is indeed *static*. Since the Lancair is not a "slab sided" airplane like so many other types, pressures are constantly changing as they move along the fslg. We have located a position that is accurate, but it has a relatively small "window of acceptability", i.e., a little bit off one way or another can produce a sizable change in pressures.

One way around the potential problem is to use a "Shark Fin" type of pitot / static unit like the Kollsman Pitot Static Tube. This will have the static line pick up in it and must be installed on the outbd leading edge of the wing. A bracket (made of fiberglass) would be made similar to that described for the heated pitot.

2. For the side mounted static source, locate the position (FS-80) per figure 16-28 and drill a small hole (#40 bit size) all the way through the fslg. We've always installed them on the right side. If you want to eliminate side slipping errors, then install one on each side and "T" them together.

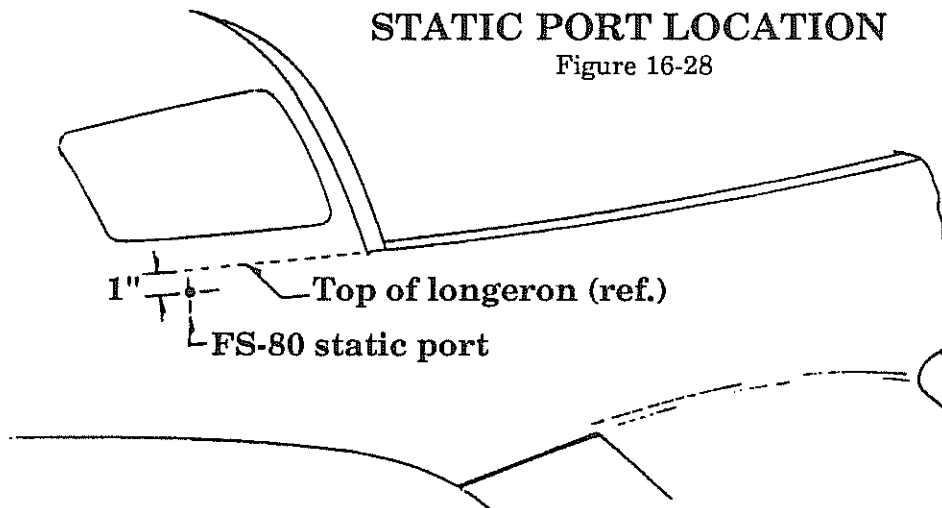

3. Two acceptable methods of implanting a pick up are shown in figure 16-29. Either will work well. Pot the tube section or Nylo-Seal fitting into the fslg side having first cut back the honeycomb and filled the area in with micro. Allow to cure. While it is curing, slip the drill bit back into the hole and push it through so as to open the hole that probably got plugged with micro. If you wax the drill bit you can simply leave it in the hole and that's it. Or, you can simply come back later and drill through once again.

STATIC PORT INSTALLATION

Figure 16-29

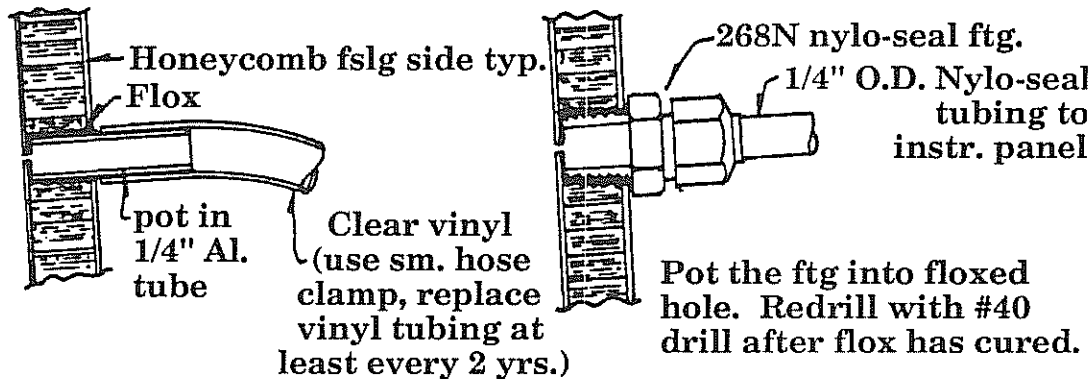

WARNING: The static port line, as it leaves the fuselage side, should angle upward first before heading down for the console where it will route to the panel. This is to prevent excess amounts of water from entering the line. (Water is not likely to run up hill.) A water trap could also be installed.

NOTE: It is a good idea to install a water trap into the static tube system at the first low point (nearest to the fslg origin). This is commonly a plastic bubble that allows water to be collected there and not continue on up into the instrument or plug the line which would make for very inaccurate airspeed, altimeter and VSI readings. It can be checked regularly and emptied as required. Many planes found at Oshkosh will not have this provision but it certainly must be recommended.

We've found that the company Lancairs do not tend to get water in the static line unless they're sitting in a windy raining condition where the wind blows on the appropriate side of the fuselage. If that happens, the static line could quickly fill up. Thus a collector is recommended. A collector bulb could be located just behind the seat, before the line routes up into the center console.

THIS CONCLUDES CHAPTER 16.

CHAPTER 17: CANOPY SYSTEMS

REVISIONS

From time to time, revisions to this assembly manual may be deemed necessary. When such revisions are made, you should immediately replace all outdated pages with the revised pages. Discard the out dated pages. Note that on the lower right corner of each page is a "revision date". Initial printings will have the number "0" printed and the printing date. All subsequent revisions will have the revision number followed by the date of that revision. When such revisions are made, a "table of revisions" page will also be issued. This page (or pages) should be inserted in front of the opening page (this page) of each affected chapter. A new "table of revisions" page will accompany any revision made to a chapter.

Arrows

Most drawings will have arrows to show which direction the parts are facing, unless the drawing itself makes that very obvious. "A/C UP" refers to the direction that would be up if the part were installed in a plane sitting in the upright position. In most cases the part shown will be oriented in the same position as the part itself will be placed during that particular assembly step. However, time goes on and changes are made, so careful attention should be paid to the orientation arrows. That old cartoon of the guy agonizing over the plans for his canoe, built one end up, one end down, should not happen in real life. Especially to you.

CONTENTS

1. INTRODUCTION
2. DRAWING LIST
3. EQUIPMENT REQUIRED - SPECIAL PARTS, TOOLS & SUPPLIES
 - A. PARTS
 - B. TOOLS
 - C. MATERIALS & SUPPLIES
4. PROCEDURE: STANDARD OPENING CANOPY
 - A. CANOPY FRAME
 - B. CANOPY SWING MECHANISM - CANOPY FWD PIVOT WELDMENT
 - C. CANOPY FRAME AFT SWING ARMS
 - D. CANOPY LATCH MECHANISM
 - E. CANOPY PLEXIGLASS INSTALLATION
 - F. CANOPY OPEN STOPS
 - G. CANOPY SEALING
5. PROCEDURE: FORWARD HINGE CANOPY
 - A. EQUIPMENT, PARTS AND TOOLS REQUIRED
 - B. MODIFYING HEADER TANK
 - C. FUSELAGE PREPARATION
 - D. CANOPY FRAME
 - E. SIDE RAIL STIFFENERS
 - F. CANOPY HINGE INSTALLATION
 - G. CANOPY PLEXIGLASS INSTALLATION
 - H. CANOPY LATCH STRIKE INSTALLATION - STANDARD LATCH
6. PROCEDURE: CANOPY COMPLETION (BOTH STYLES)
 - A. CANOPY SEALING SURFACES PREPARATION
 - B. ALTERNATIVE SEALING METHODS
 - C. ALTERNATIVE LATCHING METHOD FOR FWD HINGE CANOPY - DRAW-BOLT STYLE
 - D. ALTERNATIVE LATCHING METHOD FOR FWD HINGE CANOPY - LEVER STYLE**
 - E. CANOPY LOCKS - EXTERNAL
 - F. AFT WINDOW INSTALLATION
 - G. FINAL CANOPY FAIRING - IN PROCESS
 - H. CANOPY CLOSURE GUIDES
7. PLEXIGLASS HINTS FOR PERFECT CANOPIES
 - A. CUTTING
 - B. DRILLING
 - C. CLEANING

1. INTRODUCTION

As previously discussed, the canopy frame installation must be initially fitted in conjunction with the forward deck and the top cowling. The cowling, being best fitted with the aid of the engine for placement, will most effectively locate the ideal forward deck line. The canopy frame will thus fit to that established line.

There are two installation methods to choose from at this time; the Standard Opening Canopy (figure 1) and the Forward hinge canopy (figure 2). **If you have chosen the fwd hinge style, then you may* need to make modifications to the header tank before it is installed in chapter 11!** Refer to the specific instructions in section 5 of this chapter, the procedure for the fwd hinged canopy.

Both installations have their good points and trade-offs. The forward hinge method looks really sharp, but it will be a lot more work to install, whereas the standard method will be easier and cheaper to install.

You should review both methods before choosing, and then, after you have decided, it is again recommended that you re-read this entire chapter prior to performing the header tank installation and the canopy installation.

*Kits shipped after 9-15-91 will have header tanks with the "pockets" already installed in them, so they can be used for either canopy opening system without need of modification.

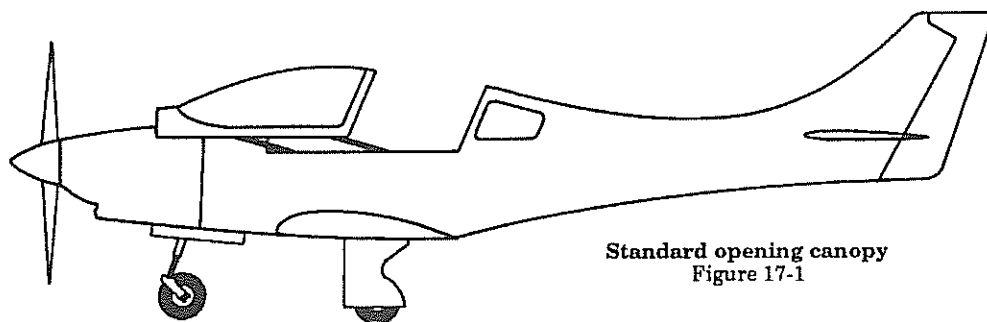

Standard opening canopy
Figure 17-1

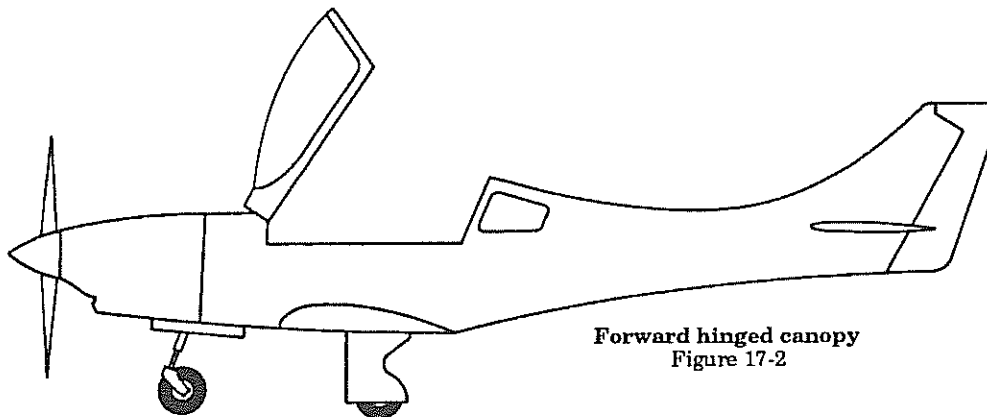

Forward hinged canopy
Figure 17-2

2. DRAWING LIST

Drawing	Page	Title
17-1	17-2	Standard opening canopy
17-2	17-2	Forward hinge canopy
17-3	17-7	Canopy frame assembly
17-4	17-8	Tracing pattern for canopy braces
17-5	17-9	Canopy frame taped in position
17-6	17-10	Canopy frame hard points
17-7	17-11	Canopy pivot arc
17-8	17-12	Canopy frame brace
17-9	17-13	Canopy frame side rail channel
17-10	17-14	Latch installation, canopy frame side rail channel
17-11	17-16	Canopy to frame assembly
17-12	17-18	Canopy forward pivot weldment
17-13	17-19	Canopy fwd pivot, keeper / saddle
17-14	17-20	Fwd canopy swing mechanism
17-15	17-22	Aft canopy "H" pivot
17-16	17-27	Canopy to frame, cleco mounting
17-17	17-29	Canopy fairing
17-18	17-30	Canopy open stops
17-19	17-31	Canopy sealing
17-20	17-34	Modified header tank
17-21	17-35	Mold for header tank pocket
17-22	17-36	Forming pocket
17-23	17-36	Trimming molded pockets
17-24	17-37	Header tank pocket mounting areas
17-25	17-38	Pocket attachment
17-26	17-39	Locating strut bracket attach points on longeron
17-27	17-41	Marking and positioning mounting bracket
17-28	17-42	Fabricating strut bracket
17-29	17-43	Drilling holes in strut bracket and mounting plate
17-30	17-44	Installing nut plates on mounting plates
17-31	17-45	Removing/installing retainer clip in rod end
17-32	17-46	Locating strut bracket
17-33	17-48	Canopy frame assembly
17-34	17-49	Tracing pattern for canopy braces
17-35	17-50	Canopy frame taped in position
17-36	17-52	Canopy frame brace
17-37	17-55	Canopy stiffening
17-38	17-58	Fairing in the gas struts
17-39	17-62	Canopy to frame, cleco mounting
17-40	17-64	Canopy fairing
17-41	17-66	Canopy latch striker installation
17-42	17-67	Aft latch, typical
17-43	17-69	Routing channel for "D" seal
17-44	17-71	Sealing side rail channel
17-45	17-73	Possible methods of sealing canopy
17-46	17-74	Alternative sealing methods to consider
17-47	17-76	Alternative latching method
17-48	17-77	Lever style latching mechanism
17-49	17-78	Positioning lever latch
17-50	17-79	Lever handle assembly
17-51	17-80	Finger recess area
17-52	17-82	Forming handle and finger recess
17-53	17-85	Installation of latch striker plate
17-54	17-87	Bonding striker plate into longeron
17-55	17-88	Canopy locks
17-56	17-93	Canopy closure guide

3. EQUIPMENT REQUIRED - SPECIAL PARTS, TOOLS & SUPPLIES

A. Parts

- Pre-molded canopy frame
- Pre-molded plexiglass canopy
- Appropriate components for your choice of canopy - either swing arms or hinges and air pistons
- Key locks (optional)
- Solenoid locks (optional)
- "P" strip or equivalent sealing strip - about 18'.



B. Tools

- drill motor
- drill bits: 3/16"
9/32"
1/8"
#12
#19
#30
- hammer
- hot glue gun or clamps
- tape measure
- rotary grinder (Dremel or equiv.)
- 1/4-20 tap & drill bit
- Clecoes (about 30)
- Cleco pliers
- Pencil



17-5

Chapter 17

REV.

0 / 11-1-91

CANOPY SYSTEMS



C. Materials & supplies

- L-320 Forward Hinge Canopy Kit (Optional)
- Uni-Directional carbon fiber (for fwd hinge canopy only)
- epoxy
- flox
- BID cloth
- micro
- sandpaper, assorted grit
- Duct tape or release tape
- MC or acetone for cleaning
- structural adhesive
- 1/4" and 1/2" white Clark foam sheets
- plastic tape (release tape)
- 1/4" phenolic material for hard points
- instant or hot glue
- Nails for making canopy frame brace
- 2" x 4" board, 16-17" long
- Inflatable "D" seal or equiv.
- 3/8" plywood or equiv.
- Some scrap wood for making a canopy frame brace / holding fixture
- Double-sided tape or equiv.
- Bondo or equivalent
- .090" aluminum for hard points
- plastic electrical tape (1/2" wide - get a couple of rolls)



4. **PROCEDURE: Standard Opening Canopy**

A. **Canopy frame**

1. Since you have already established the fwd deck location, cleco it in place as shown in figure 17-5.
2. In order to have the canopy frame maintain the proper shape, and still be able to work on it, a brace for it must be constructed. Get two pieces of plywood or equiv. and make a contour pattern of the fwd deck at the junction of the canopy frame and also a pattern of the rear roll over. These do not have to be accurate at all, just pencil them in by placing the piece of plywood on the longerons and by laying a pencil flat on the decks, trace off the contour line all the way down to the longerons. These pieces of wood should be about 6" wider than the fuselage at their relative positions so that they hang over the longerons by 3" per side. They will be used later to make a quick and simple jig to hold the canopy frame when you remove it from the fuselage. By making sure that the wood is level, it will be easy to sit the frame upside down later without it "walking around" when you're working on it. See figure 17-4. Set the wood aside.

Canopy frame assembly

EXPLODED VIEW

Figure 17-3

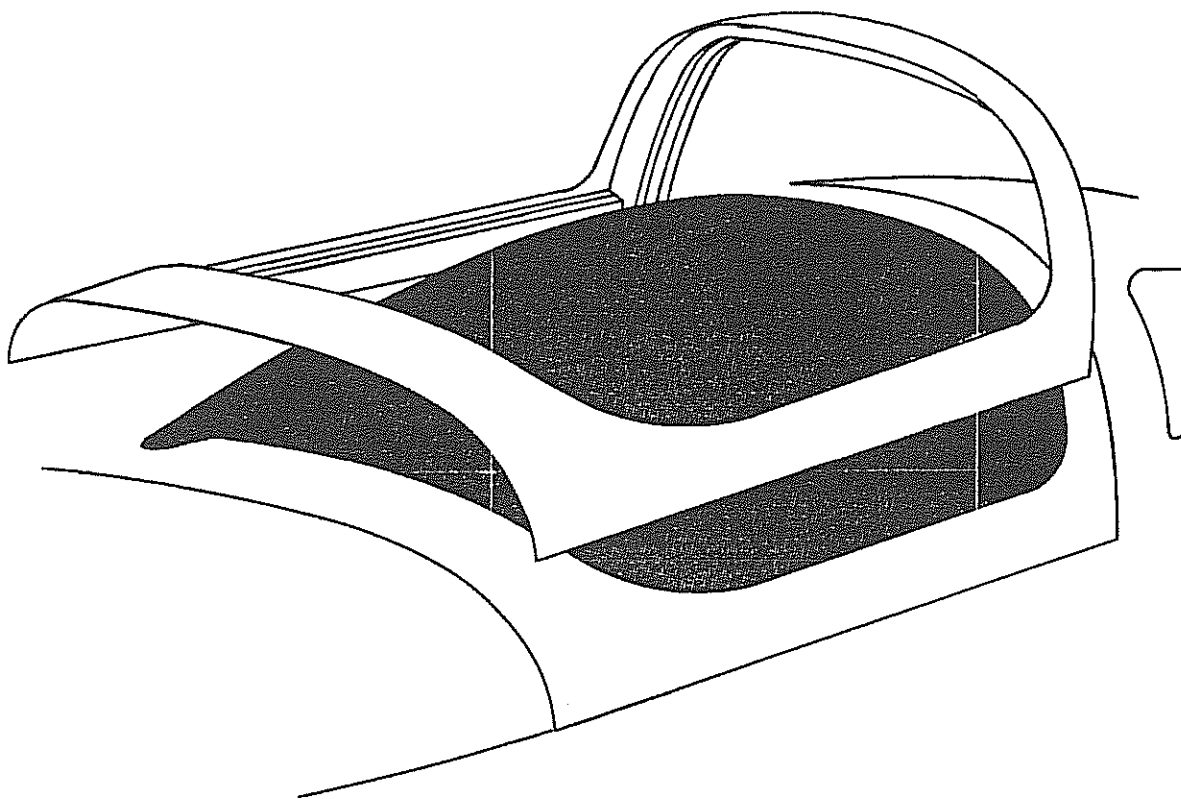

TRACING PATTERN for CANOPY BRACES

Figure 17-4

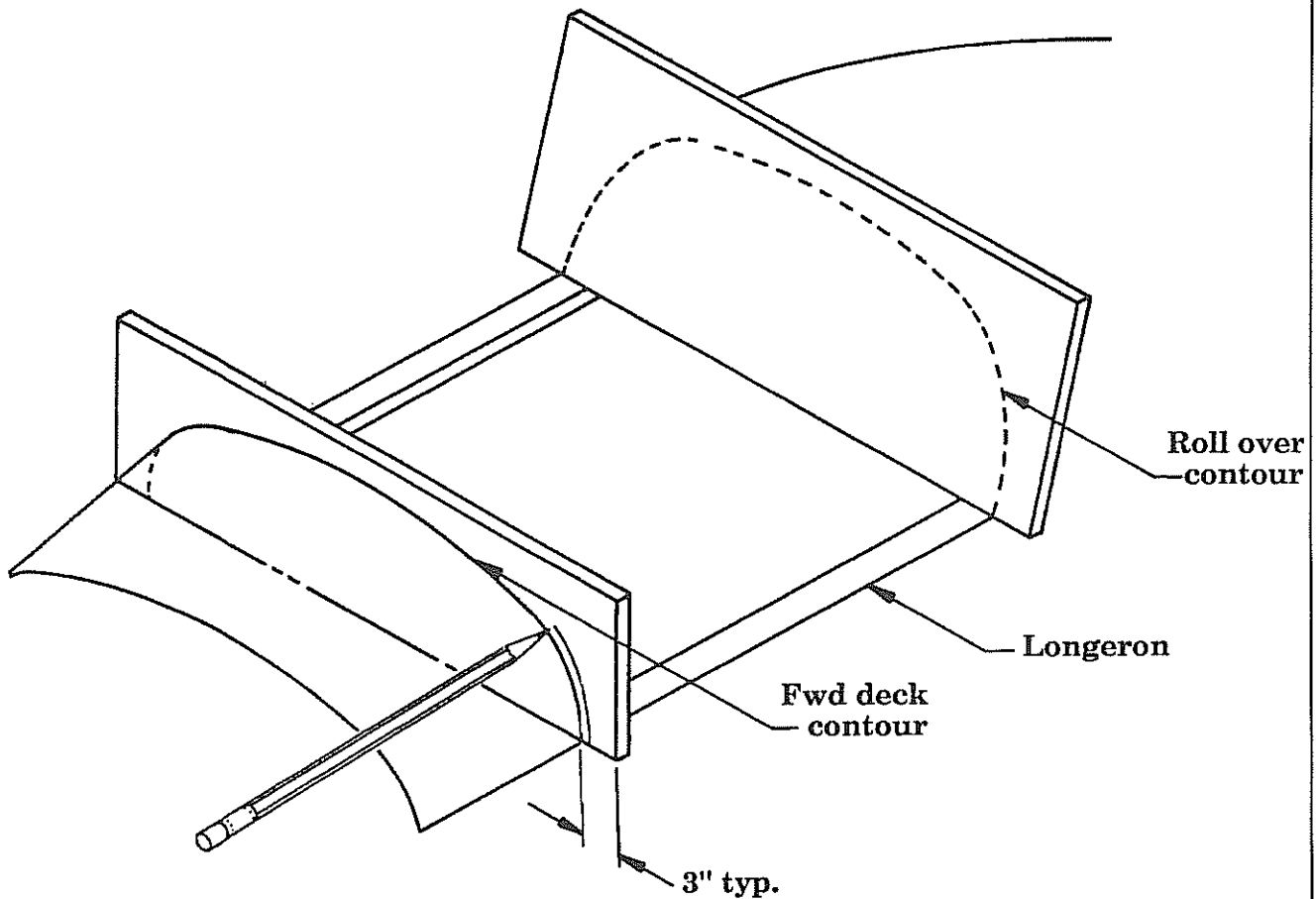

3. Lay the canopy frame over the airframe in relative position. Check for side rail alignment, the frame sides will eventually have approximately $1/8'' - 3/16''$ clearance from the top of the longerons. This is to allow for a "P" strip seal or equiv.

4. Locate the frame in a fwd/aft orientation that places it at a point which allows for complete coverage of both the fwd deck joggle and the aft roll over joggle. The frame has been factory trimmed to mate with these joggles. If at all possible, it is generally best to orientate the frame as far fwd as possible, this will provide additional instrument room since the distance from canopy to panel would be at its maximum potential. Trim and sand as necessary to establish an alignment with the L.E. of the fwd deck joggle and alignment with the T.E. of the aft roll over joggle.

NOTE: It is recommended that before you trim any of the material on the sides of the frame, first be sure that the frame is flushed up with the surfaces of the fwd deck and aft deck. The joggle may be initially too deep so use short pieces of mixing sticks to shim the frame up to a flush condition. Use dabs of hot or instant glue to hold these shims in temporary position as shown in figure 17-5.

NOTE: Do not trim the inside of the frame (where the canopy will install) until you have laid the canopy itself over and verified dimensions. You'll want to establish at least 5/8" overlap on all areas except for the front curved area where the overlap can be a little less. (The canopy will be bonded to the inside of the frame but you can verify dimensions by fitting it over the top initially.)

Canopy frame taped in position

Figure 17-5

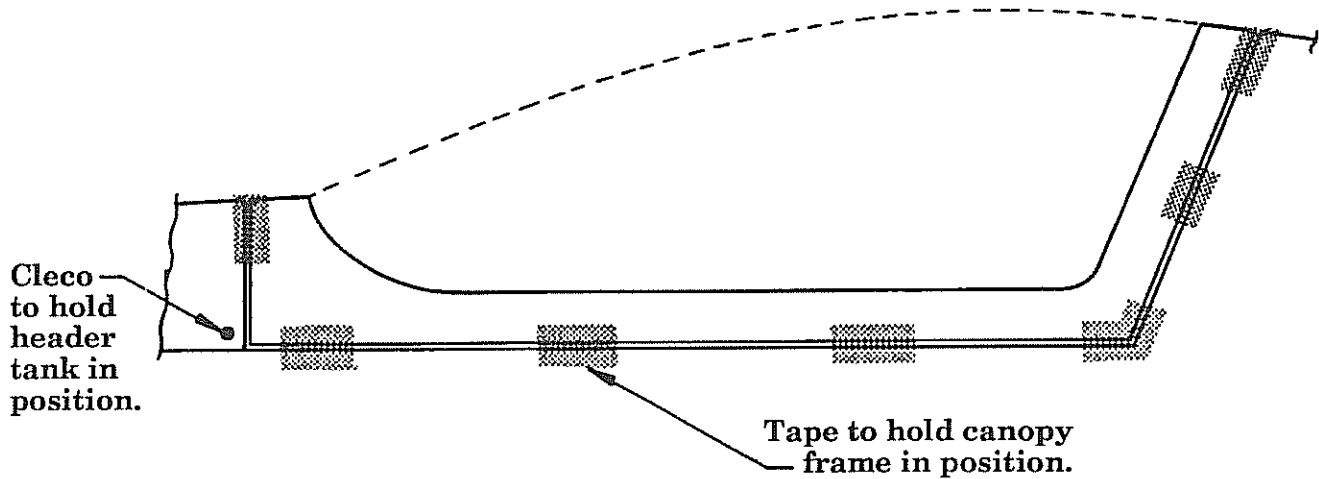

5. With the canopy frame fitted into the joggles you are ready to trim the lower edges as necessary to accurately match the frame side profile to the fuselage sides. By using mixing sticks and hot or instant glue, and cutting and sanding as necessary, position the canopy frame so that it is flush with the fuselage profile, with about 1/8" gap between the frame sides and the longerons, even fore & aft and on both sides. Either sand this to a smooth line now, or mark it well and sand it later after you install the bracing and remove the canopy frame for other steps.
6. Referring to figure 17-6, carefully lay out the hard point positions by marking their lines onto the fslg sides. Draw a line that crosses the longerons vertically and thus provides position marking reference on both the canopy frame (inside and outside) and the fslg. Label them as "fwd canopy swing, aft canopy swing, latch, etc. (This can become confusing later so some simple labeling now will eliminate some later head scratching.) Also mark the area that foam will need to be removed from to make clearance for the swing arms.

There will be eight hardpoints that must be installed for the swing arms; four on the inside of the outbd edge of the canopy frame, and four on the outbd side of the inbd edge. You will also need four hardpoints for the latches, two fore and two aft, on the outbd side of the inbd edge of the frame lip.

CANOPY FRAME HARD POINTS

Figure 17-6

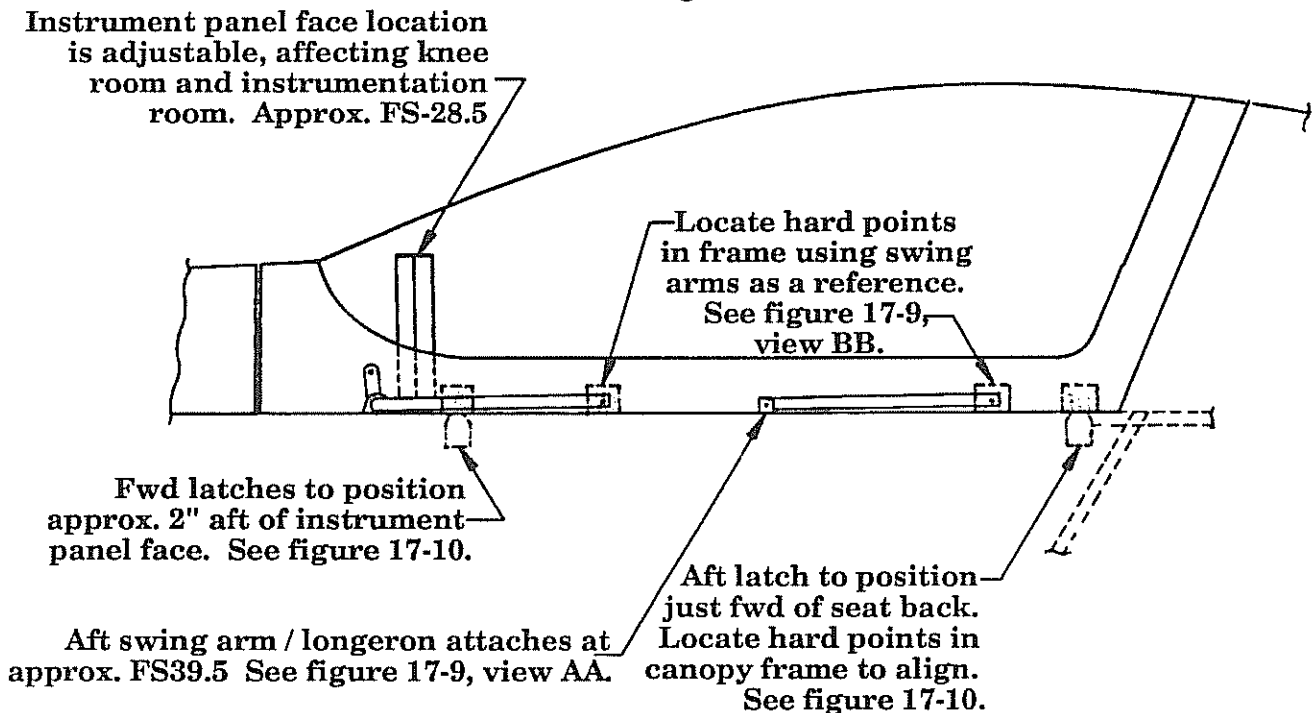

7. Referring to figure 17-7, mark off on the inside of the canopy frame the area that will have to be cleared of foam for the swing arms when they are in both the open and closed positions. Label these marks so you can recognize them later, you'll be pulling the frame off in a while to grind out the foam and you don't want to have to be putting this thing on and taking it off any more than you must.

CANOPY PIVOT ARC
FIGURE 17-7

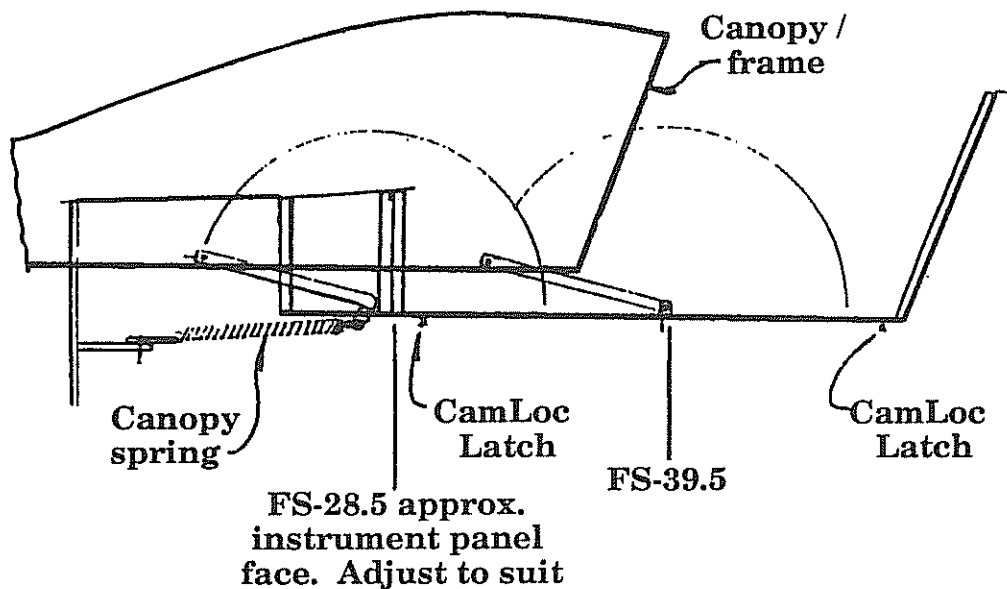

8. Now that the exterior of the canopy frame is the exact shape we want it to be, and we have all of the hard point locations marked off, we need to construct a brace to hold it in that position while we do some extensive modifying on the inside. Using a sabre or jig saw, cut out the plywood pieces you marked earlier, so that you have a silhouette that is slightly larger than the canopy frame itself. Don't bother trying to get it even close, Bondo will take care of that.
9. Sand the braces to remove any splinters that would get you later, and wipe the inside edge of the patterns with acetone or MC to clean them for the next step.
10. Referring to figure 17-8, mix up a big hot (lots of hardener) gob of Bondo, spread it along the forward part of the canopy frame from one side to the other, in spots about 2" long and a half inch deep. Squish the forward brace piece down into position, wiggling it a bit to get it down to the frame through the Bondo. Check that the top line of the board is level side to side (so it will be able to rest upside down) and true vertical (so it won't fold under when there is weight on it) and hold it for about 5 minutes while the Bondo cures enough to hold its position. Repeat this process for the aft brace.

Canopy frame brace

Figure 17-8

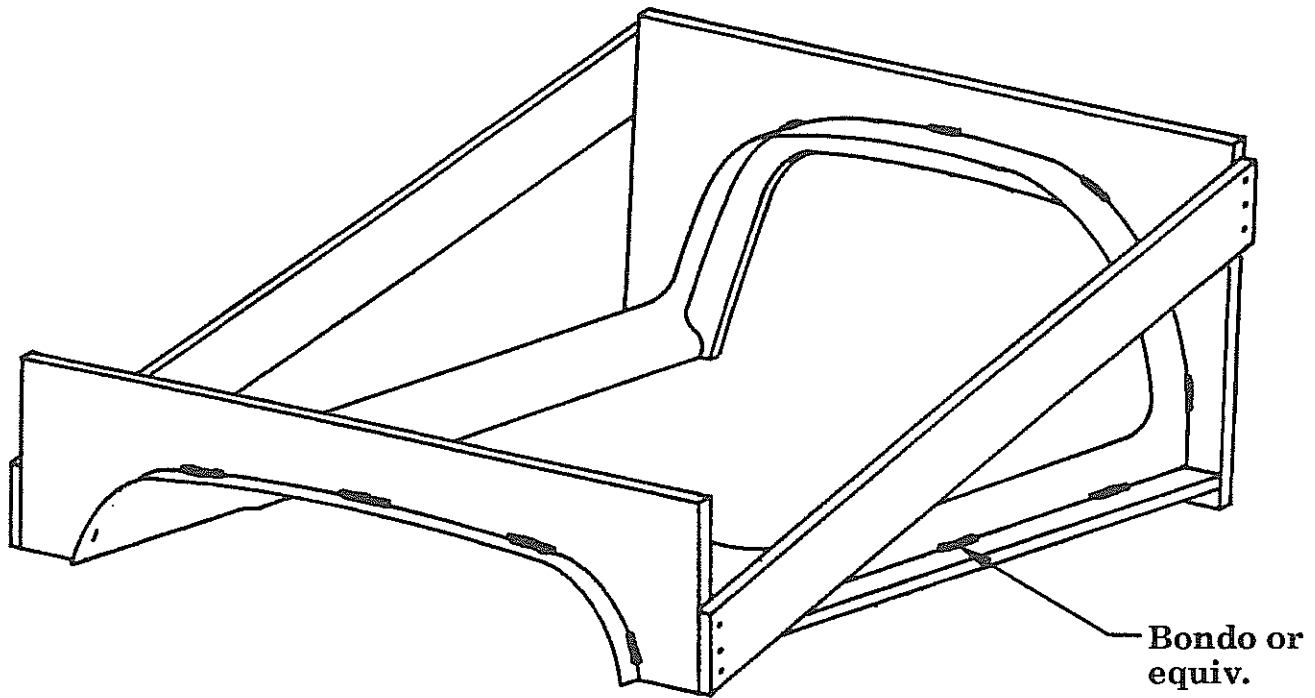

11. Nail, screw or glue a couple of pieces of wood as shown in figure 17-8 between the two braces to make them a more rigid structure. Then use some more Bondo to put a couple of fore-aft braces down the sides of the frame, bedding the wood as you did in step 6, and then screw or nail it to the front and back braces. **BE SURE NOT TO DISTORT YOUR CANOPY FRAME WHEN YOU DO THIS - When you are finished with the next steps, if you have distorted it here, the distortions will be permanent!**

Later on, when you are finished with the frame, you can simply knock the boards off with a good smack of a hammer.

12. Cut 8 pieces of .090" aluminum that are 1-1/4" square. These will be potted into the side rails (inside and outside surfaces) at all four attach points where the canopy parallelogram arms connect. See figure 17-6.
13. Cut 4 pieces of .090" aluminum that are 2" long x 1-1/4" wide. These will be potted into the inner sides of the frame where the four latches will anchor, see figure 17-6.
14. Remove the canopy frame and bracing from the fslg and place it inverted on a bench or on the floor. Sand a smooth line onto the bottom of the rails to create a finished line for the side rails, if you didn't do this in step 5.

15. Using a drill with a router bit (or using a Dremel tool), remove the foam from the inside bottom of the side rails to form a channel. See figures 17-9 and 17-10. This channel should be made such that about 3/16" of foam remains along the outbd sides, the inbd sides can be carved out on a taper so that you will end up with a glass to glass edge. See cross sectional drawing, figure 17-10. (A fairly standard "ball" type router bit is available in most hardware stores, these are sometimes called "rotary rasps".)

**CANOPY FRAME SIDE RAIL CHANNEL
CROSS SECTION VIEWS**

Figure 17-9

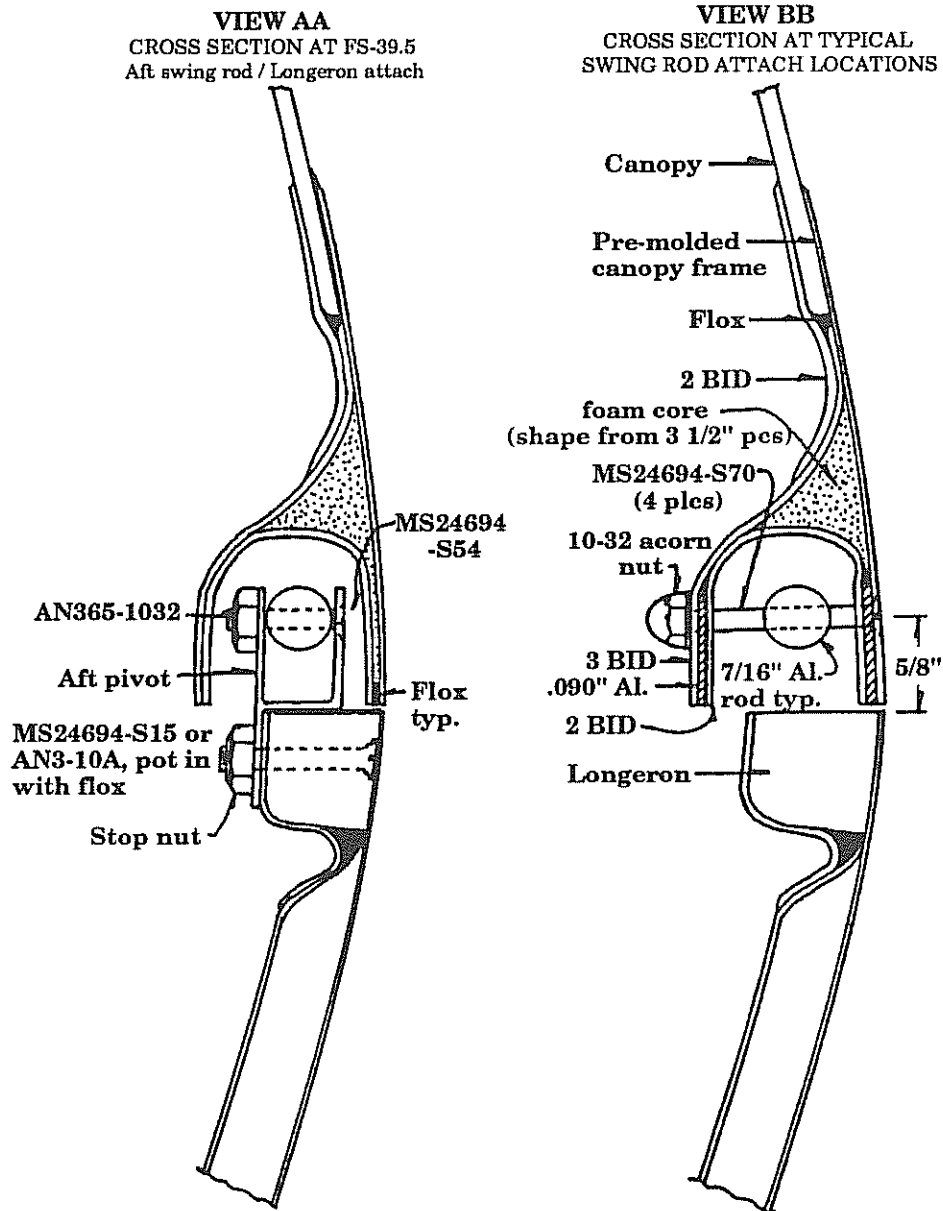

LATCH INSTALLATION
CANOPY FRAME SIDE RAIL CHANNEL
CROSS SECTION VIEW
 Figure 17-10

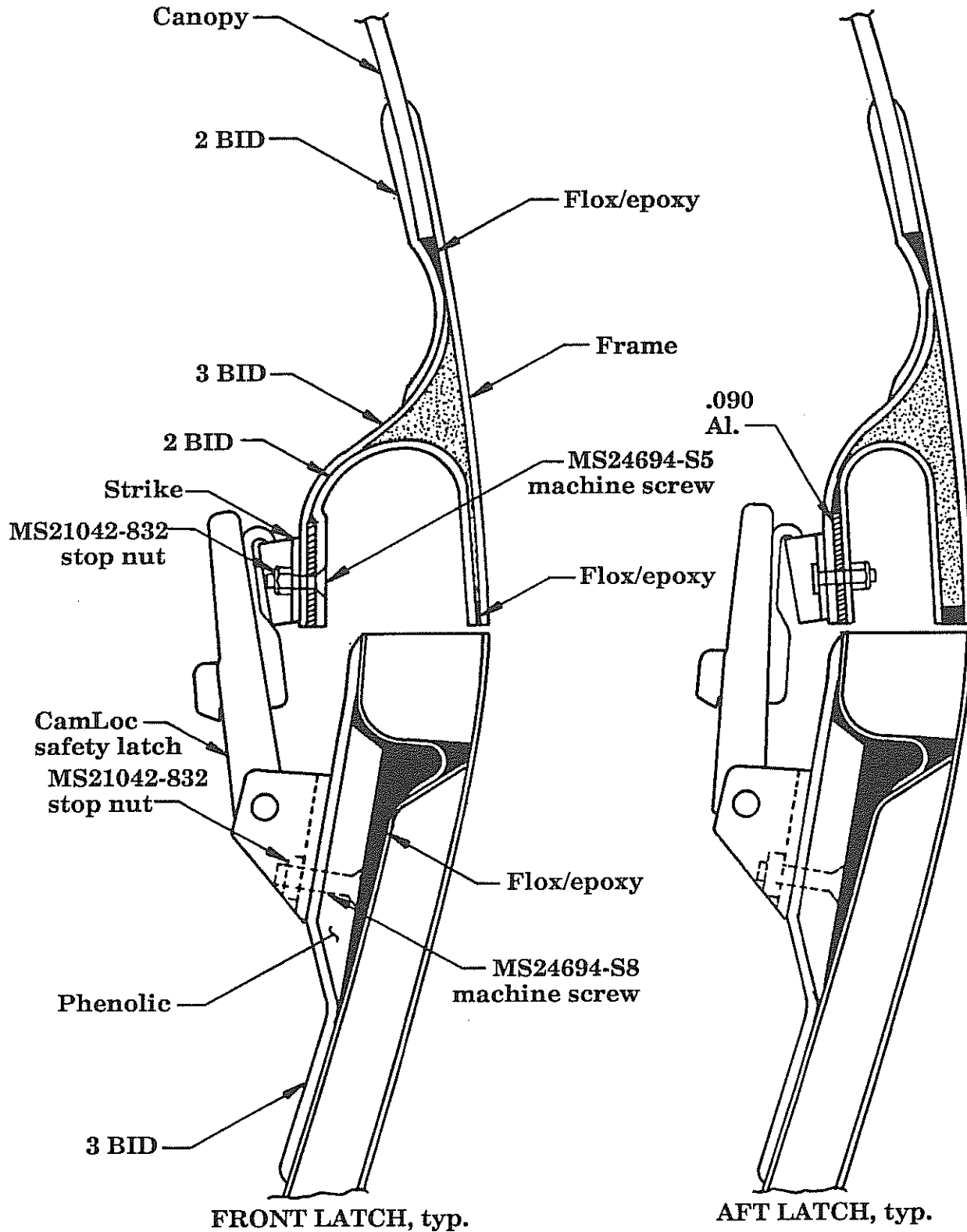

16. Once the channel is carved out fairly close to final size, go in by hand with a piece of 40 grit sand paper and give it a final sanding to smooth everything up.

NOTE: Clearances are fairly tight, particularly where the aluminum extrusion fits into the channel when the canopy is closed. Locate that area and establish proper clearances. Also the wide channel can terminate at an aft point that is approximately 1" aft of the rear swing arm attachment position however, the channel must continue aft to the point where the rear latches will be positioned. At that location, the channel can be narrower but room must be maintained to allow access for the latch "strike" mounting nuts. See figure 17-10.

WARNING: The four hard points that will attach the lock mechanisms will require the full elimination of foam against the inbd side of the channel where the aluminum inserts will mount. For structural integrity, all foam must be removed, thus the inner BID will attach directly to the aluminum inserts. See figure 17-10.

17. Remove the foam from the outbd section of the frame where the swing rod attach hardpoints will mount, sanding away all foam. Clean the area with MC or acetone. Rough up all surfaces of the four outbd aluminum hardpoints, clean them thoroughly with MC and, using epoxy/micro (or preferably, structural adhesive), bond them against the canopy frame. A small clamp should be used to hold them in place until cured. The squeeze-out of adhesive should be formed into a nice fillet, and any extra cleaned off before it hardens.
18. Locate and install the four inner hard points that will pick up the latches. Be sure to rough up the aluminum and clean it well for a good bond.
19. The fwd pivot weldment will exit the channel through a required cut in the channel walls adjacent to the instrument panel. See figure 17-11. Make this cut out now.
20. With the channel completed, it is a good idea to lay the canopy frame (with braces still attached) back onto the airframe and verify that the channel will clear all the rods that must lay inside when the canopy is closed. Adjust as required. Try to maintain as large of a lip on the outbd portion of the channel sides as possible. This will help provide a good surface upon which to place a seal strip later. With the checks made, place the frame back on the bench.
21. Apply a 2 BID lay up into the channel. Use a thin application of micro over the foam first to seal the foam pores. See figures 17-9 and 17-10.



**CANOPY to FRAME ASSEMBLY
FWD EDGE CROSS SECTION**

Figure 17-11

Foam must taper to
avoid interference
with the Glare
Shield-Dust Cover

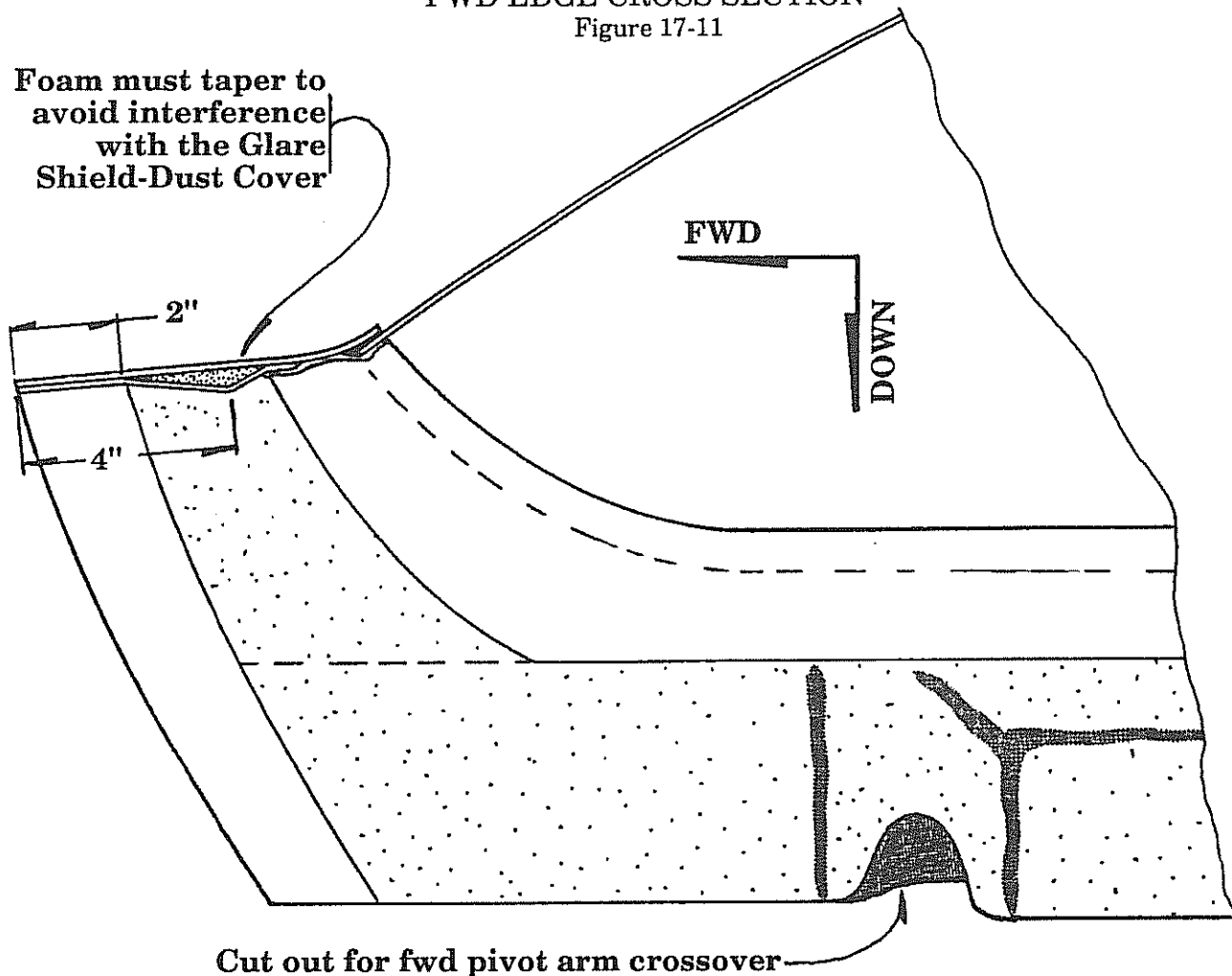

Cut out for fwd pivot arm crossover

B. Canopy swing mechanism - canopy fwd pivot weldment

The standard mechanism that opens and closes the canopy is that of a parallelogram system. There is one fwd cross weldment that crosses the fslg in front of the instrument panel and two aft swing arms that attach the aft portion of the canopy to the longerons. This will produce a movement that rotates the canopy up and forward providing excellent access into the cockpit area from either side of the plane. This system is spring loaded so that it will operate with finger tip ease.

1. Position the fwd canopy pivot weldment across the longerons. The actual FS location is not critical. If you keep at least three inches fwd of the instrument panel, then you will have room to install circuit breakers, switches, etc. along the bottom and still clear this pivot weldment. (A suitable position for the weldment is approximately FS-23).
2. The weldment must not extend more than half way over the longerons on each side. This is to allow adequate room for the canopy frame to extend down past the weldment and seal against the outbd portion of the longerons. See figure 17-12.
3. Lay the weldment down on the longerons and square it with the center line of the fuselage. Note the angle that the 12" arms form when laid on the longerons. They should approximately parallel the widening nature of the longeron spacing as they move aft, i.e., when moving aft, as the cockpit gets wider, the canopy pivot weldment should be bent to approximately follow that widening span. This can be easily tailored by simply putting a little additional bend if needed at the existing bends in the weldment.
4. Now, to make things work a little better yet, place a counter bend in the top of each arm on that weldment such to help align the through holes as approximately parallel to each other, see figure 17-12. This will help later when drilling for the attachment bolt holes in the canopy frame.

NOTE: This is not a critical fit and is not structural either. This system only functions to open and close the canopy and has no interaction with the completely separate safety latching mechanism for flight conditions.

5. Next cut the two phenolic saddles that will be used to mount the pivot weldment, see figure 17-13. These are cut from 1/4" phenolic. Drill a 7/16" hole to form the saddle then make two vertical saw cuts to complete the cut out shape. A little filing will be necessary to provide clearance for when the weldment is in the aft down position (canopy closed) and also when rotated fwd into the fwd down position (canopy open). See figure 17-12.



CANOPY FORWARD PIVOT WELDMENT

Figure 17-12

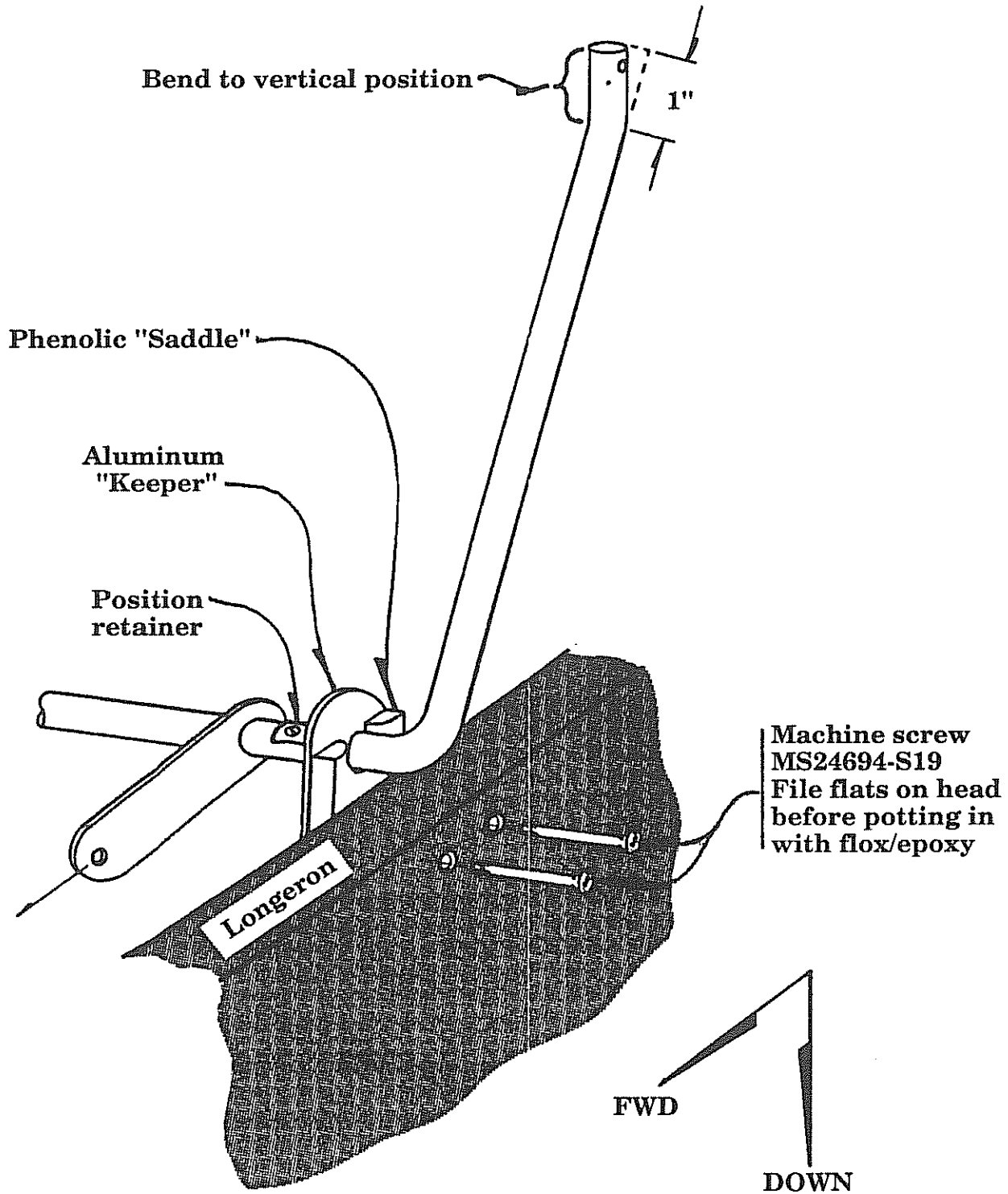

CANOPY FWD PIVOT, KEEPER / SADDLE

(2) TWO EACH REQUIRED

FIGURE 17-13

KEEPER: Al., .090" thick

SADDLE: Phenolic, 1/4" thick

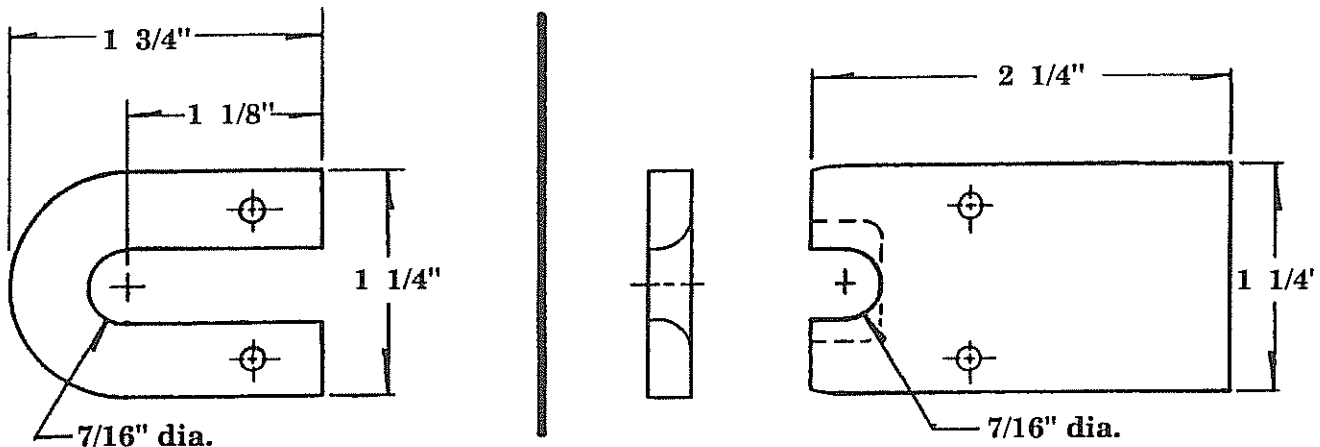

Clamp & drill (#19 bit) Saddle & keeper after Saddle is floxed in place.

6. Also make the two aluminum "keepers" that will secure the weldment down into the phenolic saddles, see figure 17-13 for dimensions.
7. Bond the phenolic saddles against the side of the longeron at the appropriate location. You will need to make a foam filler block per figure 17-14 to fill the void under the longeron. Use epoxy/micro to secure this in position. Clamp and allow to cure.
8. Next apply a 2 BID lay up over the phenolic saddles. This should contact about 1" onto the fslg all around. This 2 BID does not have to extend up and onto the longeron tops. Allow to cure.
9. After cure, position the weldment into the saddles and verify sufficient corner clearances to allow the weldment to rotate aft such that the ends of the arms are within 5/8" of the longeron tops. (The arms do not have to touch the longerons since they will be mounted higher.) Also swing the weldment fwd until an angle of approximately 25° is established. (The weldment arms must always clear the fwd deck when in the fwd position, this will generally become the basis of establishing the limit stops for the canopy which will be discussed later.)

FWD CANOPY SWING MECHANISM

Figure 17-14

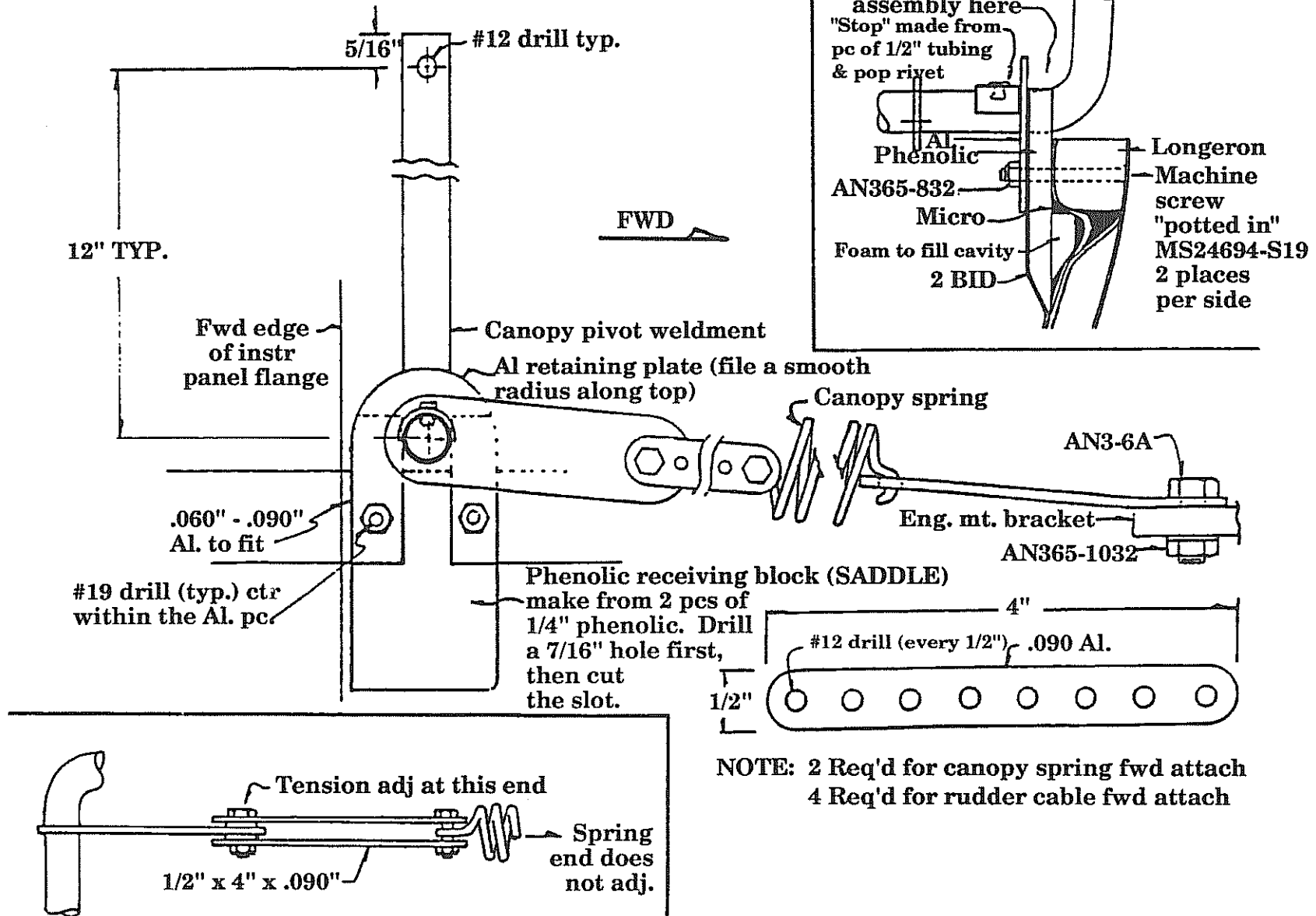

**NOTE: 2 Req'd for canopy spring fwd attach
4 Req'd for rudder cable fwd attach**



10. Slide the aluminum "keepers" down over the weldment that's in position in the phenolic saddles. The keepers should fit close but not tightly since the weldment will have to rotate under them. Check for a condition that does not allow more than about .015" clearance or looseness of the weldment in the vertical direction, i.e., you should not be able to wiggle the weldment up and down very much when held in position by the keepers.
11. Locate the two required bolt holes in the bottom of the keepers and drill them first into only the keepers. Use a #19 drill bit.
12. Using a small C-clamp, clamp one side of the keeper down to secure its position over the weldment thus allowing room to drill a hole through the other side. Drill the opposite hole through the entire assembly, all the way through the longeron and through to the outside of the fslg. Temporarily set a machine screw through this hole to secure positioning. Then release the clamp and drill the remaining hole.
13. Put in the machine screws from the outbd side. Use the standard approach of grinding "flats" on the side of the countersink head and then flux the screw into position. Allow it to penetrate into the longeron enough to add a little micro fill over it. This will require only about a .010" depression. Don't drill it too far. Allow the fluxed in screws to fully cure before tightening up on a nut. See figures 17-12 and 17-14.
14. From a short piece of 1/2" tubing, cut a section in half to form a "stop" for the side to side movement of the weldment. See figures 17-12 and 17-14. Set these in position with either a pop rivet or standard AN rivet, either will work well.
15. The tabs on the side of the weldment will attach to the big springs which can be adjusted to counter balance the weight of the canopy. See figure 17-14. These springs will be attached to the tabs with a simple "link" as shown in figure 17-14. Make one link set for each side.
16. The springs will be a tough pull. They will attach to a tab bolted to the lower engine mount brace arm on the top mount pads. See figure 17-14. They can be made adjustable by installing an adjuster arm similar to that described for the rudder cables. Always place the spring into the last hole and make adjustments by moving the attachment bolt.

WARNING: Be very careful when setting these springs. Avoid letting them snap free since they could recoil and hit you in the face!



C. Canopy frame aft swing arms

These are very simple rods that complete the parallelogram movement by supporting the back of the canopy frame. They attach to a fitting off the longeron and attach through the back of the canopy frame.

1. Select the "H" section aluminum extrusions and trim them down to resemble figure 17-15.
2. Locate the attach point on the longeron where these fittings will be installed and install using two machine screws. Locate the holes in the aluminum fitting first and use it as a guide in drilling through the longerons. You should also predrill the holes that will attach the swing rods. Pot the machine screws in from the exterior by creating "flats" on the sides of the countersink heads and pot them in with epoxy/flox.
3. Attach the swing rods per figure 17-7.

**AFT CANOPY "H" PIVOT
RIGHT SIDE SHOWN
FIGURE 17-15**

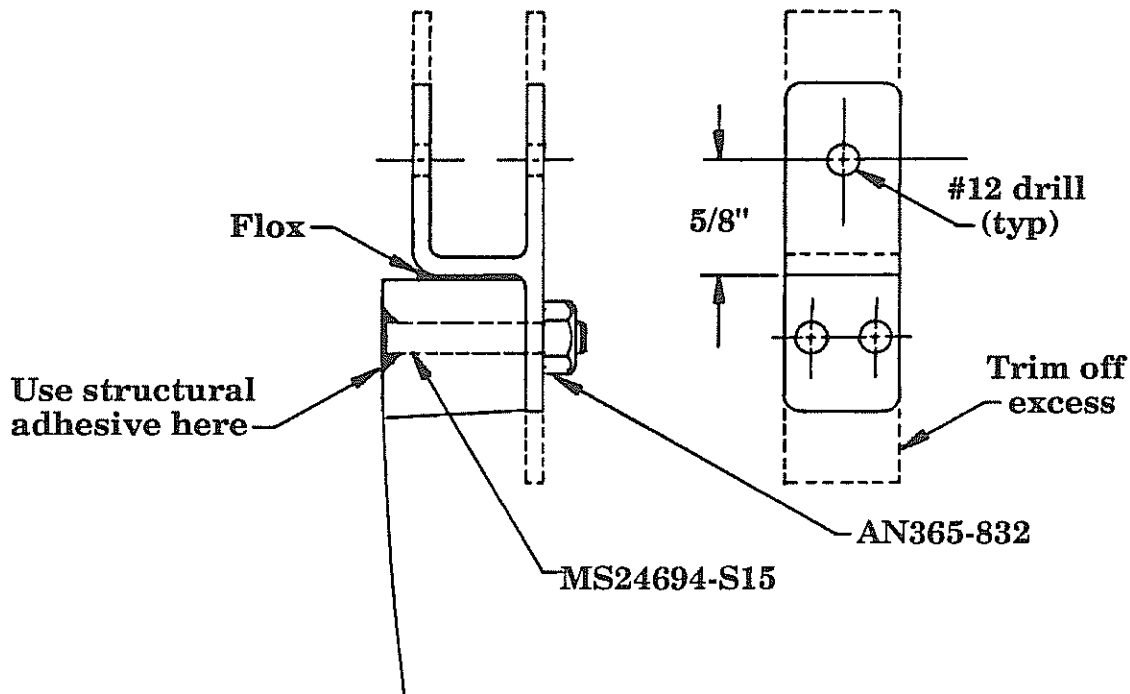

4. Carefully mark the locations of the canopy frame attachment holes that are on the ends of the aluminum pivot arms. These locations must be carefully marked onto the sides of the fslg and should represent a position for the rods when they are elevated approximately 1/16" above the top of the longerons. If you make two long reference lines on the side of the fslg to locate each hole, then finding their position once the canopy frame is laid onto the plane will be easy. (This is similar to the described method of locating the holes for the middle gear door brackets, refer back to page 6-18, step 9).
5. Place the canopy frame onto the fslg and locate the four attachment hole positions. Use a #12 drill bit and drill through the outer side only of the side rail.
6. Once you've drilled through the first (outer) wall of the side rail, reach in and slip the aluminum rod onto the drill bit to verify alignment. Then drill the rest of the way through the inner side rail of the canopy frame.
7. With all four hole sets drilled, you can slip the long machine screws in and the canopy frame can be rotated up. It will seem quite wiggly and clumsy - don't worry though. After the canopy is bonded into position, additional stiffeners are laid up and once the springs are set, it will work nice and smooth.



D. Canopy latch mechanism

The in flight latch mechanism is a very straight forward installation using CamLoc® safety latches. These latches will pull over center for a positive lock with an additional safety catch to prevent accidental opening. These are each load rated at more than 4 times the required strength.

1. First locate the positions of the hard points in the inner side rails where the latches will be positioned. Put a pencil mark on the glass to easily depict their location.
2. Position and mount the "strike" for the latches by drilling the two #19 holes through the strike as a guide and thus through the inbd side rails of the canopy frame. The strikes should be positioned even with the bottom of the side rail. See figure 17-10.
3. Next position the latch onto the strike and mark a reference position onto the sides of the fslg to show the location needed for the latch build up attachment block. See figure 17-10. Note the distance inbd from the fslg sides required for the latch when it is properly hooked on the strike. This will require the latch to be positioned off of the inner surface of the fslg skin.
4. Form a phenolic block that shims the latch out to the required position and orientation. Cut a smaller phenolic piece to fill the cavity under the longeron. This does not have to be a real snug fit, simply use epoxy / flox to pot this in and fill any little voids. See figure 17-10.
5. Drill and install the two machine screws that will pot in from the back side of the phenolic to secure the latch onto the face block. Use the MS24694-S8 screws and pot them into the phenolic in the usual manner.

WARNING: When potting the machine screws into the phenolic block for the latches, do not remove any more of the phenolic than is absolutely required to lock the heads into the piece. Remember to file flats on the screw heads to prevent the screw from slipping. You may also use 1/2" phenolic if the installation of the latch requires additional shim distance.

NOTE: When setting the proper vertical alignment of the latches, check to verify that the internal latch adjustment is set to a mid range. The hook on the latch can be screwed up or down to fine tune the amount of pull produced when the latch is closed. This should be in the middle of its adjustment range to provide final adjusting room on both directions.

6. Now bond the phenolic onto the fslg using epoxy/flox. Clamp in position and allow to cure.

7. Wrap the machine screw studs with a piece of tape to keep the upcoming resin off of the threads. Now sand to smooth the edges of the phenolic, apply a floc fillet where necessary and add a 4 BID lay up over these four attach points. Contact at least 2" all around on the fslg sides. As always, be sure to clean and sand the bonding areas first. Make a good effort to keep the area of the phenolic (now with the 4 BID over it) smooth and flat so a good base is established for the latch to tighten up onto. Allow to cure then remove the tape and clean up the BID around the studs so that the latch will again seat solidly against the phenolic/BID base attachment.

8. Secure the latches with the two small (MS21042-832) all steel lock nuts. These are required since the available space is limited. Also mount the "strikes" using MS24694 machine screws. It is generally best (for clearance reasons) to insert them from the inside of the channel (for the fwd strikes) and attach the all steel lock nuts onto the outside. This will require a little hand operation of the counter sink. If there is room, you can of course run the screws in from the outbd side and place the nuts on the inside.

9. To attach the aft "strikes", since there is nothing else there, you can run the screws in from the inbd side and set the all metal lock nuts on the inside of the channel.



E. Canopy plexiglass installation

NOTE: DO NOT REMOVE THE PROTECTIVE COATING FROM THE CANOPY UNTIL INSTRUCTED TO DO SO!

1. With the canopy frame upside down on the bench, STILL IN ITS BRACE, lay the canopy into it. Adjust it from left to right and fwd to aft until a good fit is established. Note the areas of overlap. You should have about 5/8" minimum around all sides with less around the front curvature.
2. Trim the canopy frame and sand the edges smooth. This will NOT be a finished paint line but it will determine that line to some degree. The actual finished paint line will be inside of the trim line by approximately 1/4".
3. Prior to bonding the canopy into the frame, sand a gradual bevel onto the outside of the cutout, this will help the transition during "finishing" later.
4. Also sand and smooth the inside frame surface where the plexiglass will be attached.
5. Now place the canopy back into the frame (inverted) and run a felt tip marker around the outside of it to indicate on the plexiglass wrapping exactly where it will register back into the frame for bonding purposes. Transfer this line onto the inner side of the canopy protective coating as well.
6. Trim the canopy if necessary. Consult the recommended directions for canopy cutting produced by Airplane Plastics, which has been reproduced in this chapter in section 7, "Plexiglass Hints For Perfect Canopies".
7. Using a #30 bit, drill holes through the frame about every 6" around the entire perimeter of the canopy, directly adjacent to the edge of the plexiglass. These will be used for clecoes which will serve as temporary clamps to hold the canopy in position during cure. Refer to figure 17-16.
8. Remove the canopy and peel back the protective coating, on the outside of the canopy, to a point beyond the felt marker line. Come back with plastic electrical tape (1/2" wide works best since it bends around contour lines easier) and remask the exposed canopy such that the tape line is just inside (by 1/8") the actual canopy frame line. Refer to figure 17-17. You'll be able to see the reference line marked on the inner protective coating. Make sure there are no other exposed areas of the canopy showing. All little peeled spots on the protective coating (inside or outside) must be covered with a piece of tape.
9. Sand the exposed surface of the canopy with 50-80 grit sand paper.



CANOPY TO FRAME, CLECO MOUNTING
FWD EDGE
Figure 17-16

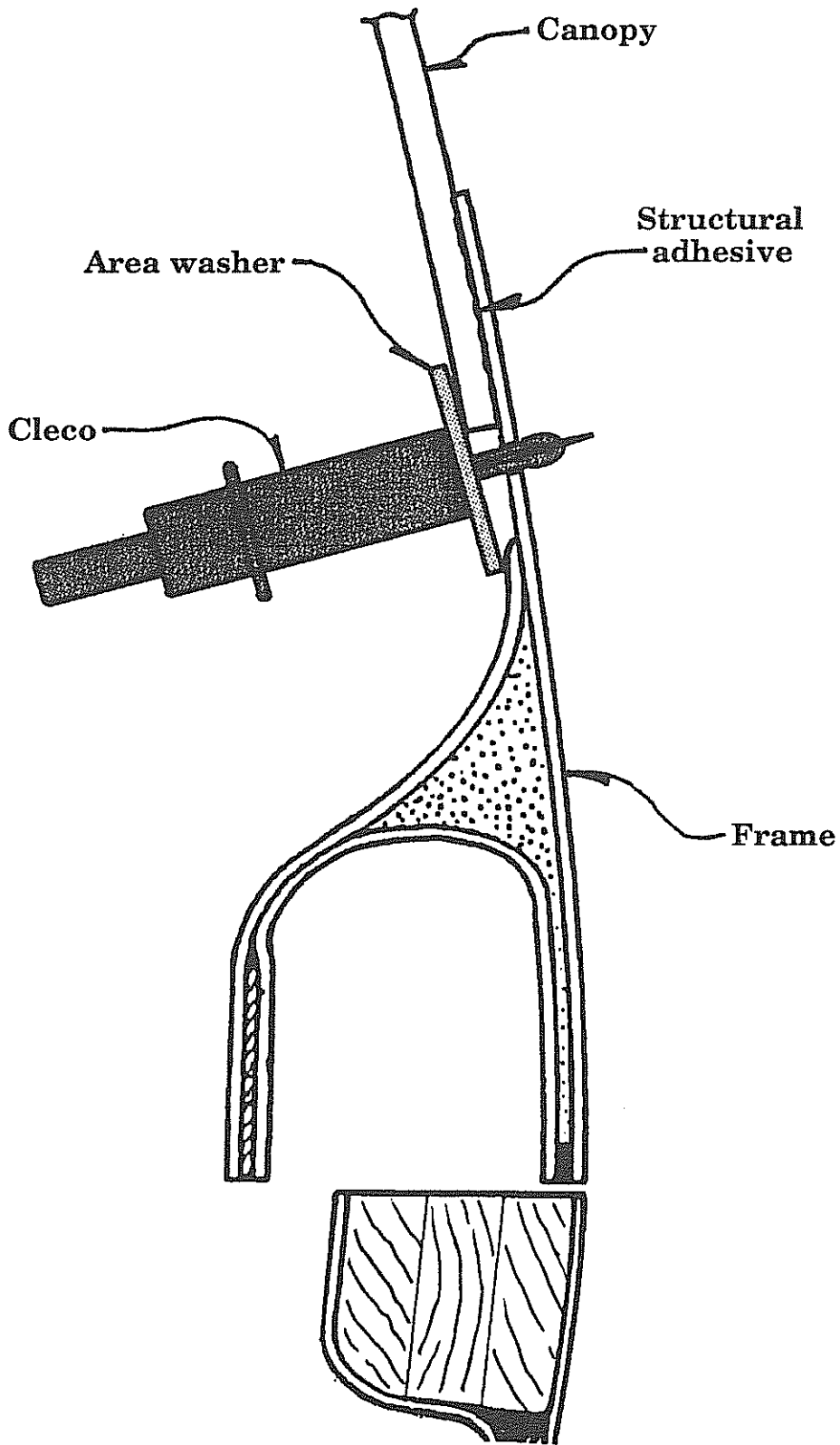

10. Mix up a batch of structural adhesive (with 5-10% flox added to thicken it up a bit) and spread a film on both the canopy and the frame.
11. With a little help from a friend, carefully place the canopy into position and set all the clecoes from the inside. It may be helpful to place an area washer over the cleco to attain a little more surface area on it while clamping however, it usually works quite well without these washers. If the clecoes have any tendency to slip off, then use the washers. As you set the clecoes, press down firmly on the canopy to squeeze out excess adhesive. Wipe this away as you proceed. You will generally be able to witness the bond area integrity by seeing the contact through the hazy (sanded) plexiglass. It turns darker when it has good adhesive contact. If you find that added pressure is needed in certain areas, just drill for a couple more clecoes.
12. When all the clecoes are set, carefully lift the unit off the bench and place it back onto the fslg to cure in the actual position. This is just a final safety measure to insure that you are not locking in any kind of twist in the canopy frame during this bonding process. With the canopy/frame positioned onto the fslg, wipe off any excess adhesive that squeezed out along the outside. Allow to cure at least 24 hours at room temperature.
13. Next, remove the canopy/frame and invert it back onto the bench top. Remove all the clecoes and clean away the protective coating from the inside. Peel it back about an inch and retape with plastic electrical tape to within 1/8" of the bond line. This bond line should be the same as on the other surface.

At this time you may carefully beat the brace off of the canopy!

14. Sand with 50-80 grit and clean. The fwd area of the canopy will form a ridge where the glass extends down away from the frame. Sand the edge of the canopy slightly and fill the remaining area to form a micro fillet so the BID tapes will install properly. This will also help to stiffen the front end. See figure 17-11.
15. Add 2 BID all around the interior perimeter of the canopy. Overlap at least 1" onto the frame. On the side rails, extend the BID tape down 1" past the point where the channel begins to roll out. This is to add additional stiffening to that area. See figure 17-17.



Canopy fairing
Figure 17-17

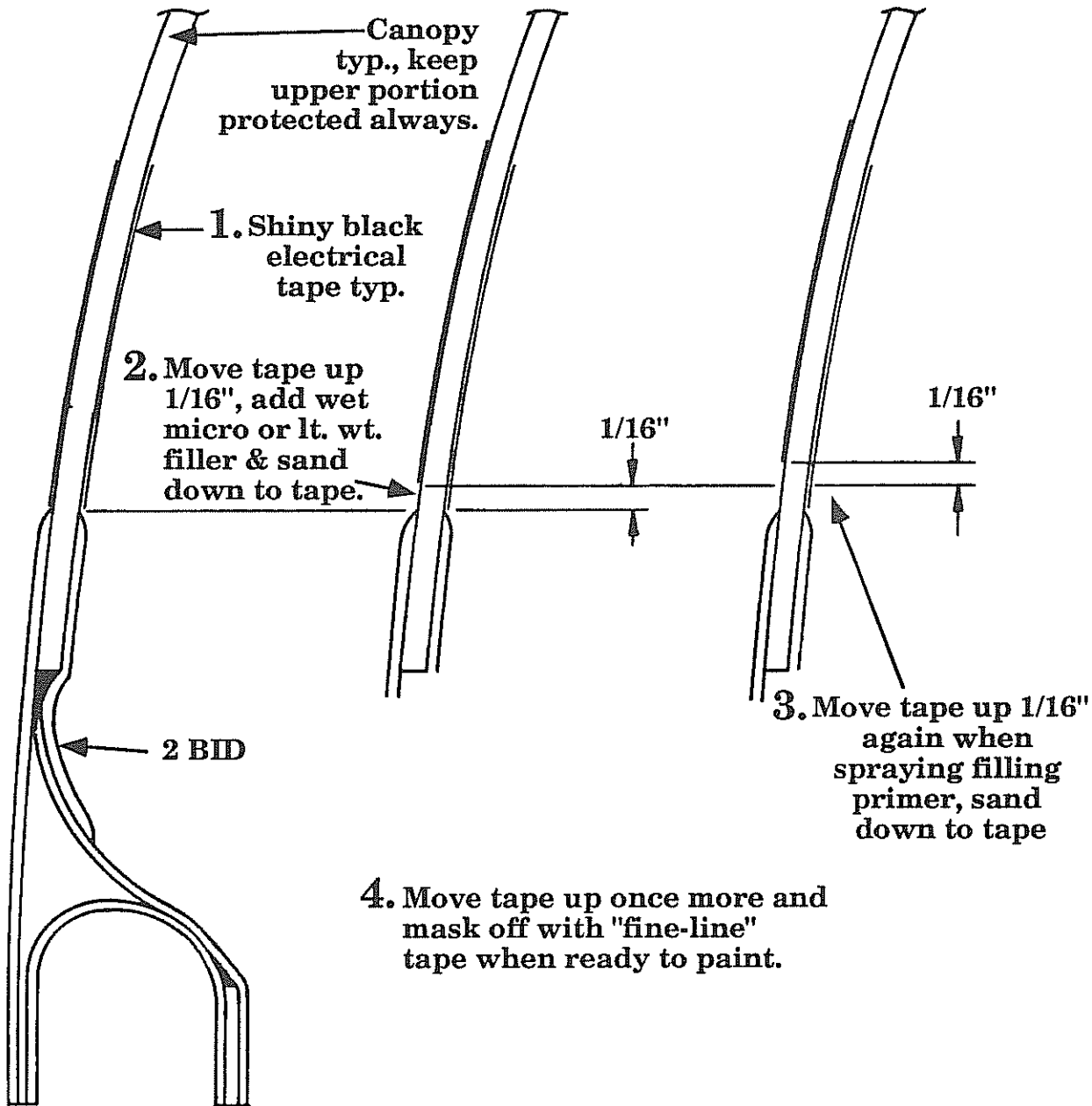

F. Canopy open stops

1. The canopy must have stops that prevent it from rotating fwd (open) too far. These should be established at the front pivot weldment.
2. Make two phenolic shims that can be bonded (epoxy/flox) into the channel just aft of the point where the pivot weldment bolts into the canopy frame. See figure 17-18.
3. To establish this stop, open the canopy and support it so that it is as open as possible without contacting the fwd deck. There should be at least 1/2" clearance preferably so that even with a bouncing action, it will not hit the fwd deck (and scuff your paint).
4. Grind some small shims that can be bonded into the inside top of the canopy frame channel so as to contact the pivot weldment arms and prevent any further fwd rotation. See figure 17-18. They do not have to be very closely carved to shape since the epoxy/flox will fill any little voids. Wrap the aluminum arms in plastic tape then insert the carved shims with a generous amount of epoxy/flox added. Lower the canopy down onto the shims and allow to cure. You may need to clamp a retainer type brace temporarily to prevent the shim from slowly being wedged back out of position. Sand it smooth later, no BID are required.

The edge of the canopy frame channel at the aft swing rod locations can also be adjusted so as to create a stop as well.

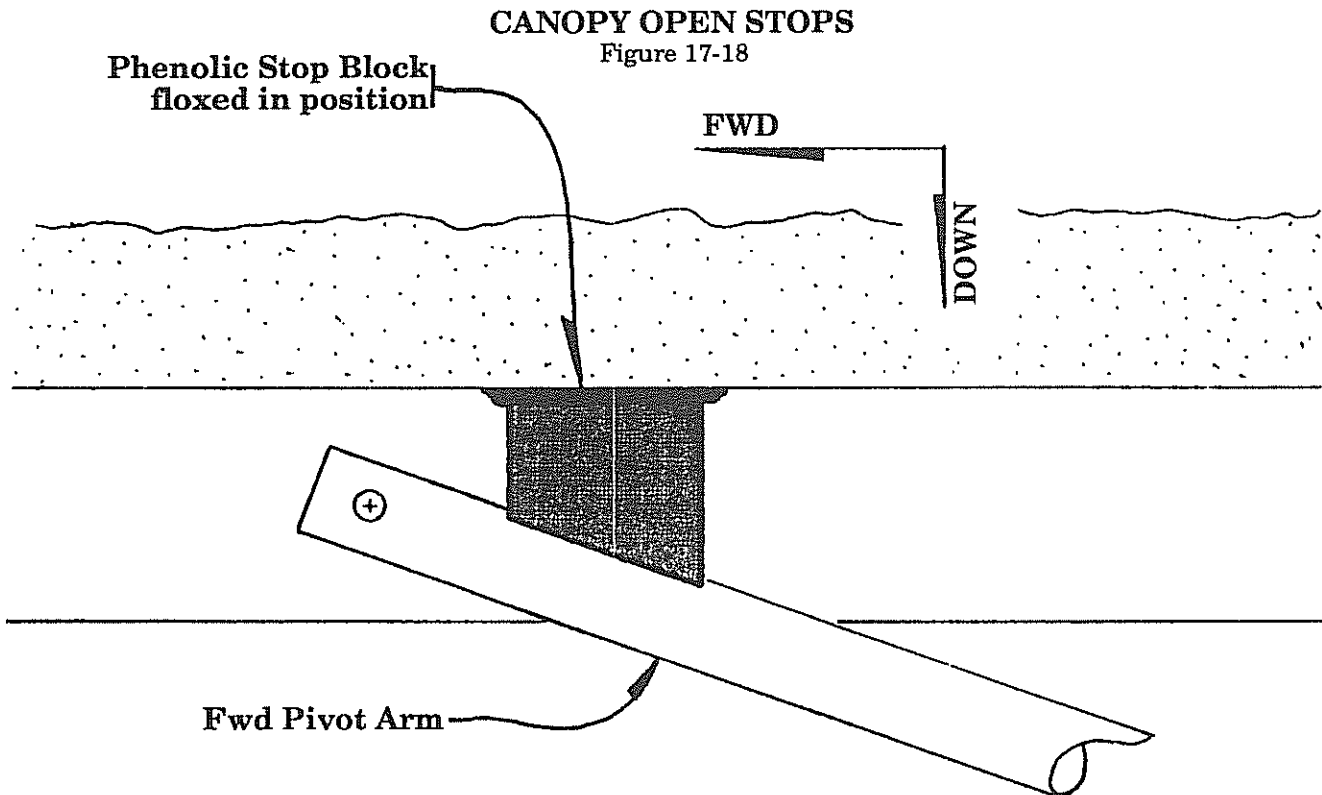

G. Canopy sealing

There are several commercially available rubber seals. The common "P" strip, while working quite well along the front and sides, does not last too long. It is however, pretty cheap, so it can be easily and quickly replaced without too much time or cost. The silicone rubber seals are the best.

1. The aft deck line is generally the toughest to achieve a good seal against. This is because it's a low pressure area up there and difficult to seal. The best means of sealing is to seal against the two faces of the roll - overs, not along the aft joggle as you might think of as being best.
2. The roll overs should be about 1/4" apart, so a relatively large seal strip can be nicely fitted along either of these faces such to seal well on the other face. See figure 17-19.
3. The fwd edge of the canopy frame will seal down onto the dust cover or it can seal directly onto the fwd deck joggle. This will depend on clearances and how you choose to fit the instrument panel dust cover which also sits on that same joggle.

At this time, refer to info beginning on page 17-69, "Canopy sealing", choose a method shown or devise your own and install it at this time, then continue through that section, installing your canopy locks and aft windows. From here thru page 17-68 apply only to the fwd hinge canopy system.

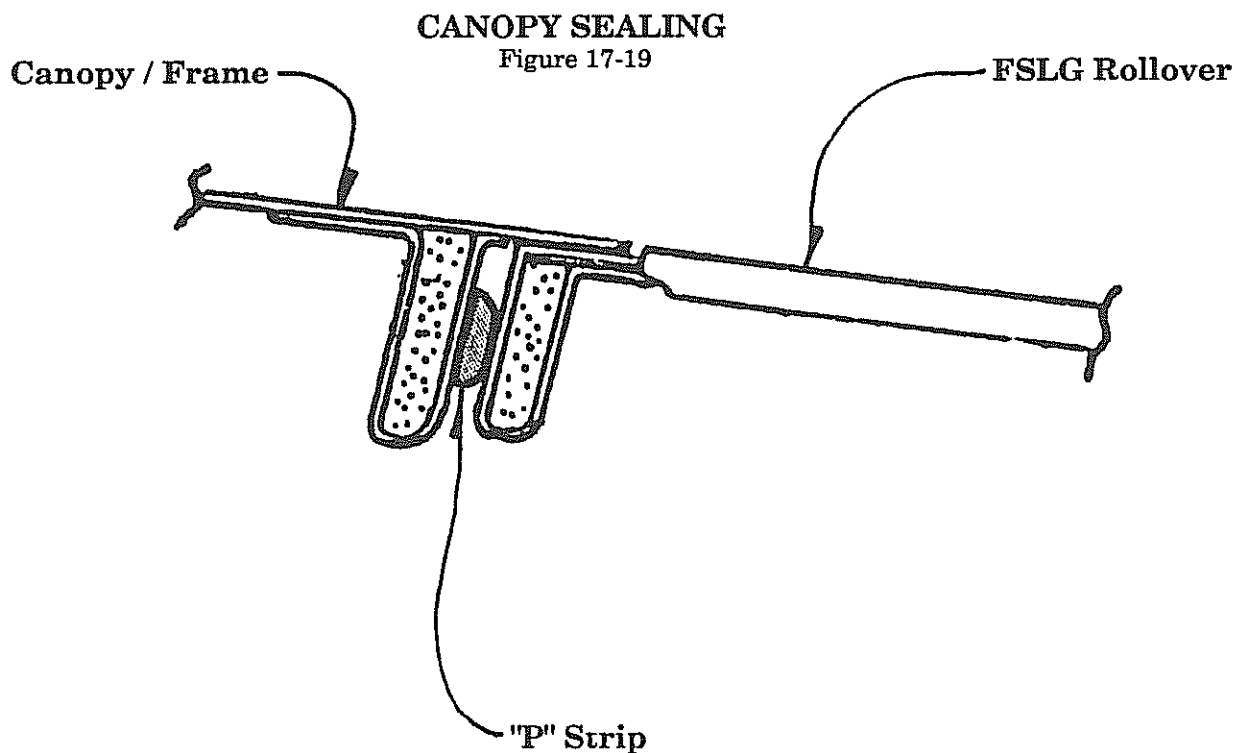

5. **PROCEDURE: FORWARD HINGE CANOPY**

This section is to provide the information necessary to mount your Lancair 320 canopy as shown in figure 17-2. The normal mounting method is shown in figure 17-1. This installation may require alterations to the header tank (chapter 11, "Fuel System"), but any of the three header tank mounting configurations (permanent, hinged or screw mount) can still be used (Note - we do not recommend permanent installation of the header tank, since it severely limits future access to rudder pedals and engine mount bolts, and expansion of your instrumentation cluster!). If your kit was shipped after 9/15/91, you should receive a header tank as shown in figure 17-20, which is already modified for the forward hinge canopy type installation. If you have one of the older tanks, it will have to be modified per the instructions included here. This section will detail the modification of the header tank and installation of the Forward Hinge Canopy. Read these instructions through entirely at least once before proceeding with these modifications.



17-32

Chapter 17	REV. 0 / 11-1-91
CANOPY SYSTEMS	

A. Equipment, parts and tools required:

Parts: Forward Hinge Canopy Kit
Blueprint "Q"

Tools: 3/8" wrenches (2)
3/16", 9/32" and 1/8" drill bits
Drill motor
Hammer
Hot glue gun or clamps
Tape measure
Router
1/4-20 Tap & drill bit

Materials: L-320 Forward Hinge Canopy Kit
Uni-Directional Carbon Fiber, 5" wide x 80' (ft.) long
Epoxy/Flox mix
Material for BID lay ups
Bondo
Sandpaper, #40 Crit
White foam sheets, 1/4" & 1/2"
Structural adhesive
Plastic tape
Epoxy/micro mix
Nails
2x4" board, 16-17" long
Hot glue (or clamps)
Inflatable "D" seal or equiv.
3/8" plywood or equiv.
Some scrap wood for making a canopy frame holding fixture
Thin plastic, like supermarket grocery bags
Double-sided tape or equiv.



B. Modifying header tank

Chapter 11 calls for attaching the header tank to the fwd deck. Before doing this, we need to install pockets in the header tank to accept the hardware for the canopy hinges. If your kit shipped after 9/15/91, it should already have a modified header tank. Refer to drawing 17-20.

Modified header tank

Figure 17-20

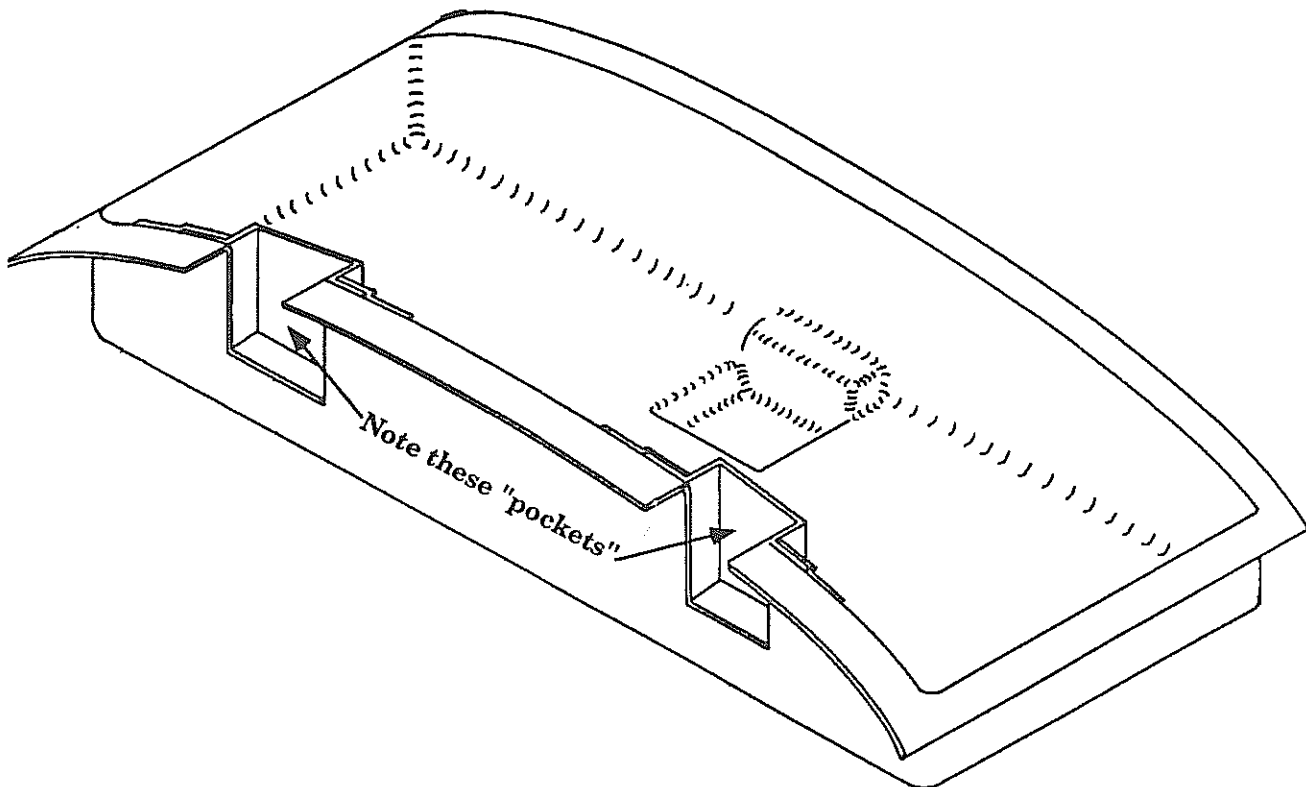

If your tank has these pockets already installed, proceed to chapter 11, page 7 and begin the forward deck alignment there. When you are back to this point in assembly, you can skip from here to top of page 17-39, as all of the intervening steps have been performed for you already.

If your tank does not have these pockets, begin with step 1., below.

1. Put tape or caps over the ends of the fuel tank fittings so that nothing from the following steps can get into them and form an obstruction.
2. Place the header tank in position on the forward deck, with the forward deck mounted in it's cradle.

3. Mark areas of header tank to be cut out for pockets (refer to blueprint "Q", L-320 FWD HINGE CANOPY, for locations).
4. Mark outline of header tank on fwd deck, and mark where pockets will be.
5. Cut out pocket areas.
6. Make foam blocks (or pcs of 2x4 wood) per figure 17-21, contouring to fwd deck shape.
7. Cover blocks with plastic release tape.
8. On a flat sheet of plastic bag, make 3 BID lay ups over the blocks and forming the flanges, as shown in figure 17-22.

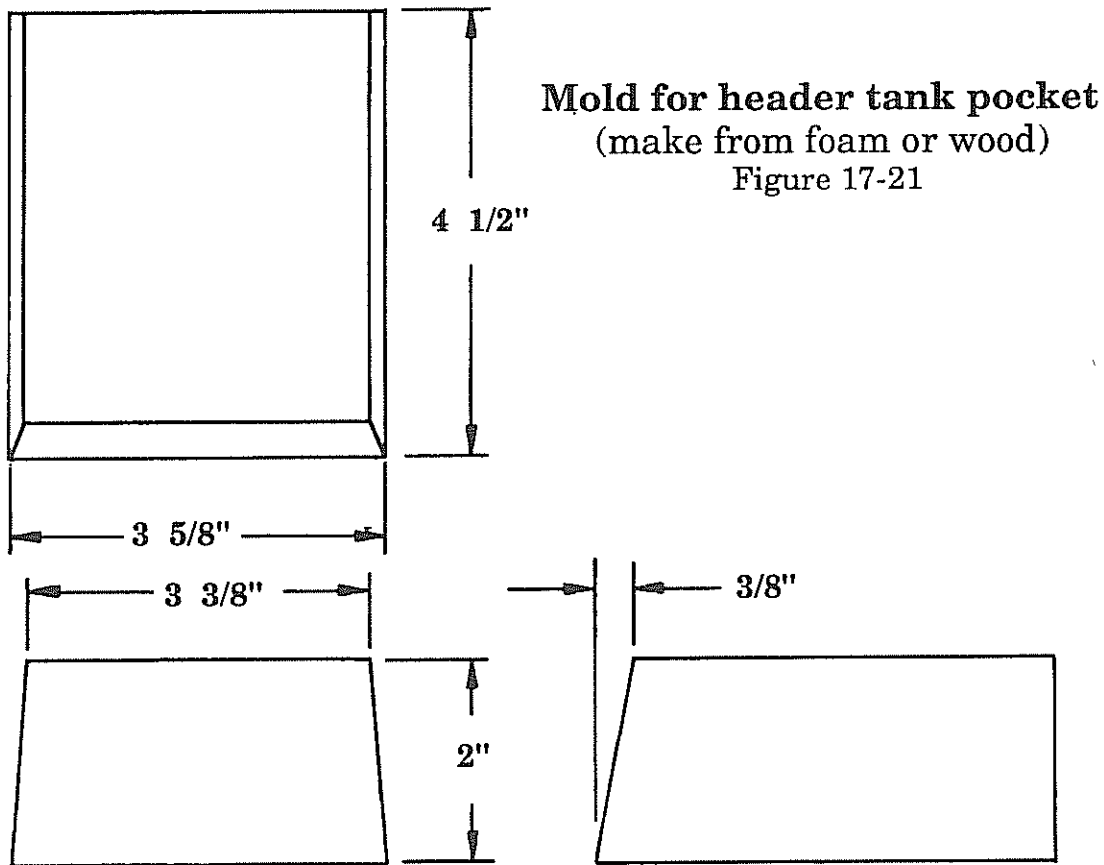

FORMING POCKET

Figure 17-22

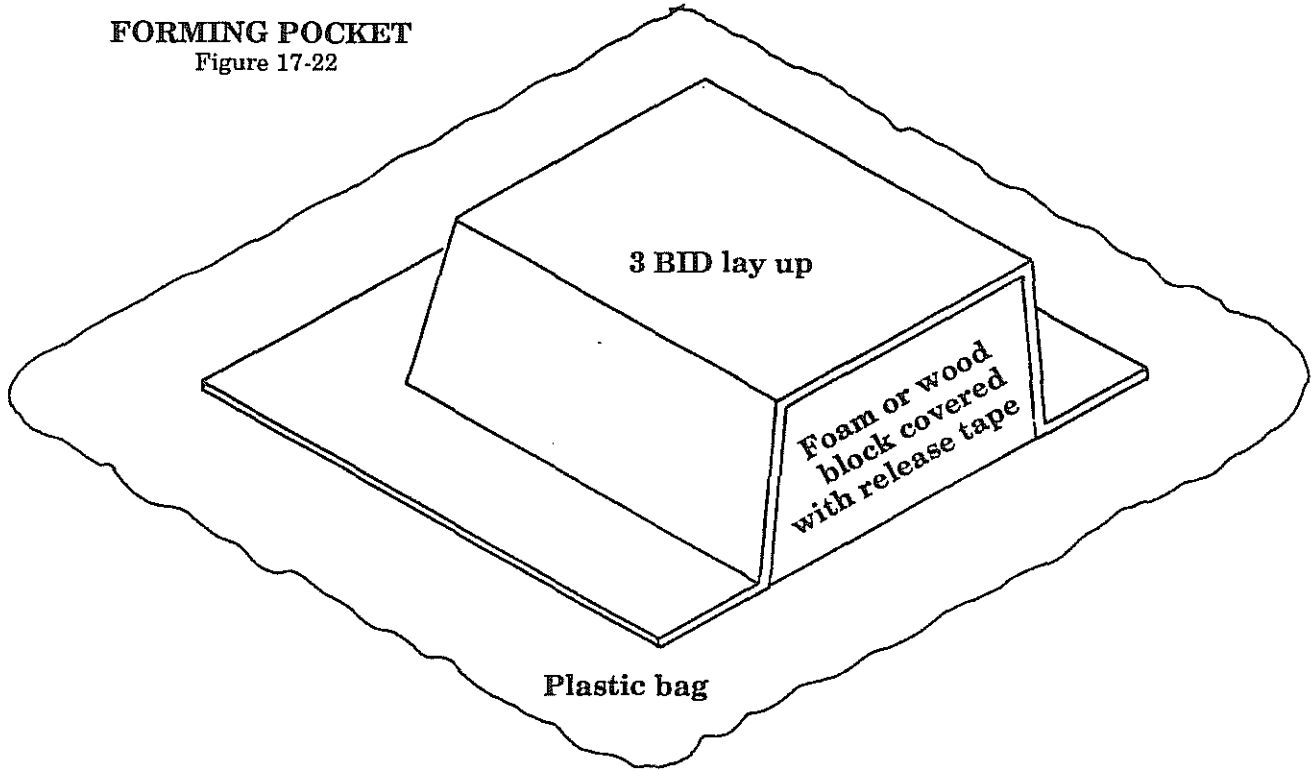

9. When dry, remove from plastic sheet, pry out taped blocks and trim molded pockets per figure 17-23.

TRIMMING MOLDED POCKETS

Figure 17-23

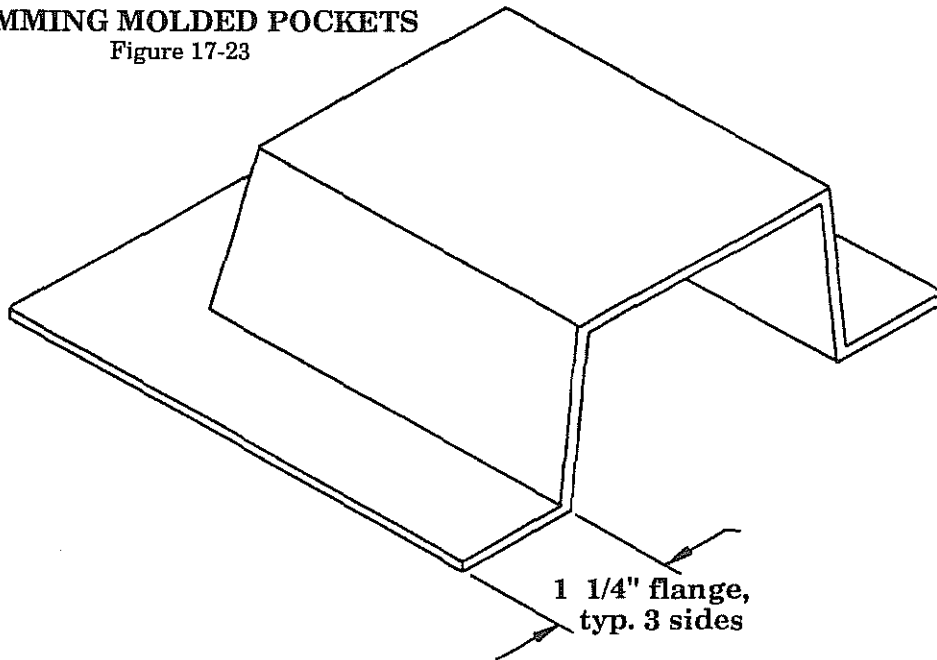

HEADER TANK POCKET MOUNTING AREAS
Figure 17-24

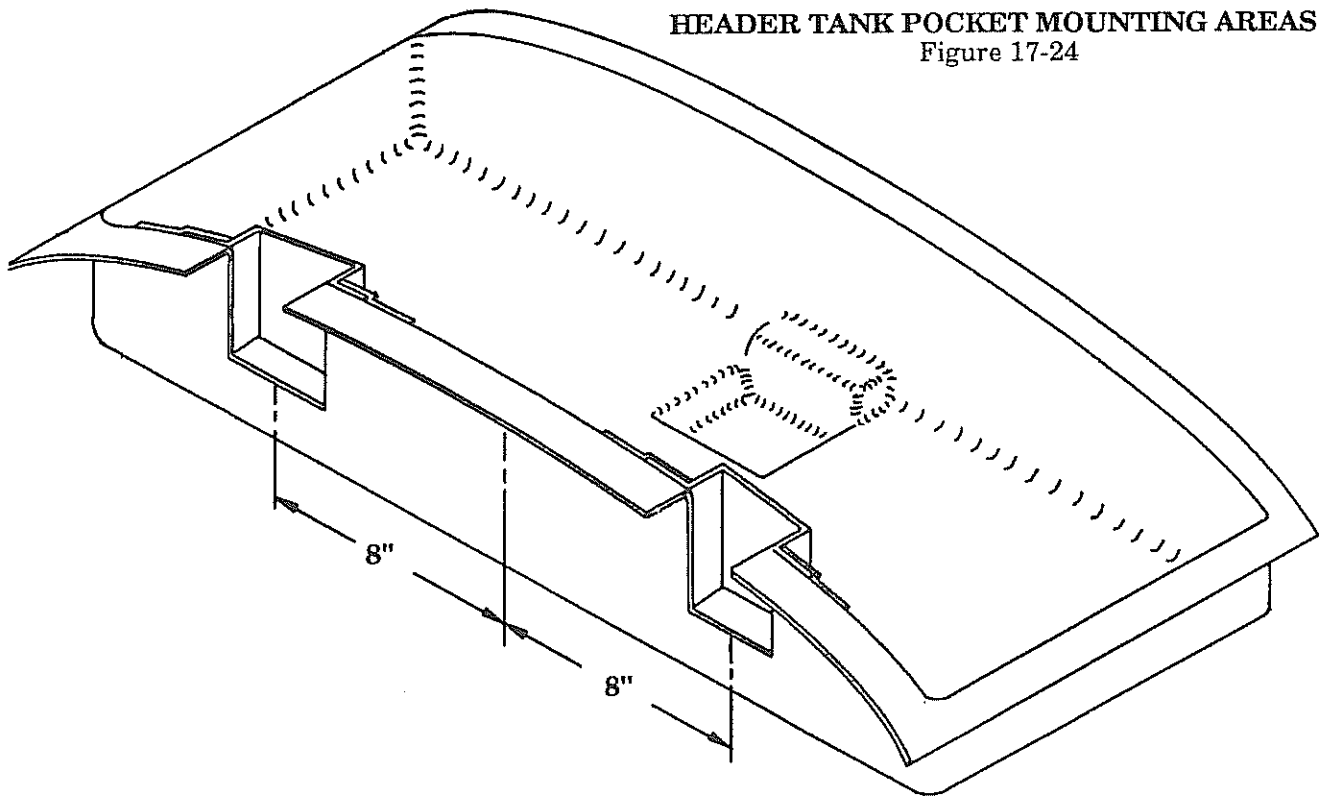

10. Position pockets on inside of header tank and mark positions, see figure 17-24.
11. Using #40 grit paper, 'scuff' the inside of the header tank where pockets will go. Clean surfaces of pockets and header tank with acetone or MC.
12. Using structural adhesive, bond the pockets to the inside of the header tank and clamp in place, wiping off any excess adhesive before it hardens, and leaving a bit to act as a fillet for the BID to be applied later. Let cure before proceeding.
13. Lay up a 3 BID attachment strip around pockets as shown in figure 17-25.

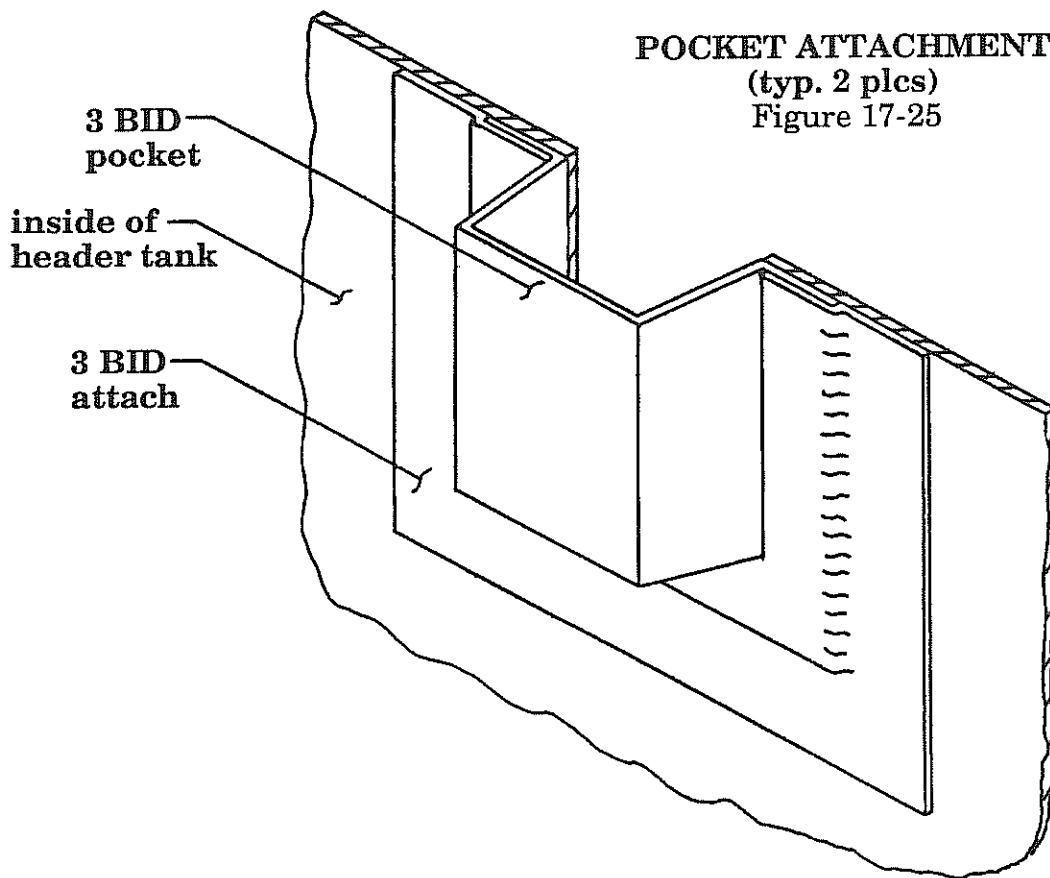

14. Remove the tape or caps from the header tank fittings and proceed with the section in the manual for attaching the header tank to fwd deck (chapter 11). When you attach the header to the fwd deck, you will, at that time, attach the top of the pockets to the fwd deck. **AT THAT TIME, LAY IN THE 8 BID STIFFENER SHOWN ON DWG "Q".**

NOTE: IF YOUR HEADER TANK HAS GEL-COAT ON IT, IT MUST BE REMOVED FROM ANY AREAS THAT ARE TO BE BONDED.

You can now return to page 11-7, and perform the steps in the manual until you get back to this chapter. At that point, you can proceed to page 17-39 and begin at the top of the page.

As previously discussed, the canopy frame installation must be initially fitted in conjunction with the forward deck and the top cowling. The cowling, being best fitted with the aid of the engine for placement, will most effectively locate the ideal forward deck line. The canopy frame will fit to that established line.

C. Fuselage preparation

1. Referring to figure 17-26 and to the blueprint "Q" for "L-320 FWD HINGE CANOPY", measure aft to FS-17.6, and put a mark on the top and inboard sides of both longerons as shown below.

LOCATING STRUT BRACKET ATTACH POINTS ON LONGERON

Figure 17-26

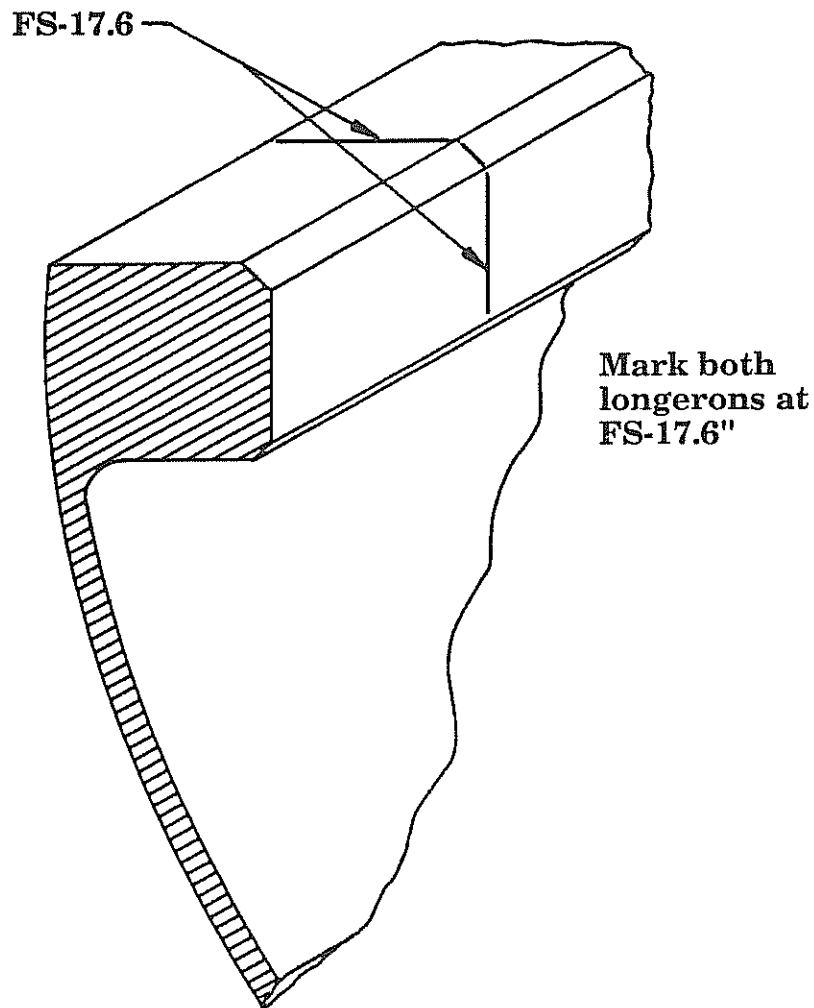

2. You need to make a mounting plate to support the strut brackets that will be mounted at the FS 17.6 position on each side of the aircraft. On your bench, lay out a piece of plastic and, using a marking pen, draw a square that is 2" wide and 8" long, making the lines dark enough to be seen through the lay up that follows.
3. Lay up 5 BID on the plastic, about 9" by 3", overlapping the pattern you have drawn. Don't worry about making the edges neat. When the mounting plate layup is still in the green cure stage, trim the edges to the pattern you have drawn. Allow to fully cure on a nice flat surface.
4. After the part is fully cured, cut it in half such that you now have 2 mounting plates, each about 2" x 4" in size.
5. Remove the plastic from the mounting plates. If you used the sandwich method, be sure you remove the plastic from *both* sides of the parts.
6. Draw a line down the center of both mounting plates, in the lengthwise direction. Mark one part "L" for left, the other "R" for right.
7. Doing first one side then the other, place each mounting plate against it's respective longeron at the FS 17.6 point and line up the center line on the mounting plate with the line you drew on the longeron. Slide the plate down until the top of the plate is 1/8" below the top edge of the longeron. Mark the plate as shown in figure 17-27 at the bottom point of the longeron. Remove the mounting plate and draw a line across it, as shown in figure 17-27, that is 3/8" below the marks denoting the bottom of the longeron.
8. Again refer to the mounting plate shown in figure 17-27. Measure out 7/16" from the center line, in each direction, on the line you just made, and mark as shown for two holes to be drilled later. Make a mark for a third hole, on the center line, 1-1/4" down from the other two. Don't drill the holes yet.
9. Using the 1" x 1-1/2" aluminum angle provided in the kit, make two strut brackets as shown in blueprint "Q" (they are mirror images of each other).



Marking and positioning mounting bracket

Figure 17-27

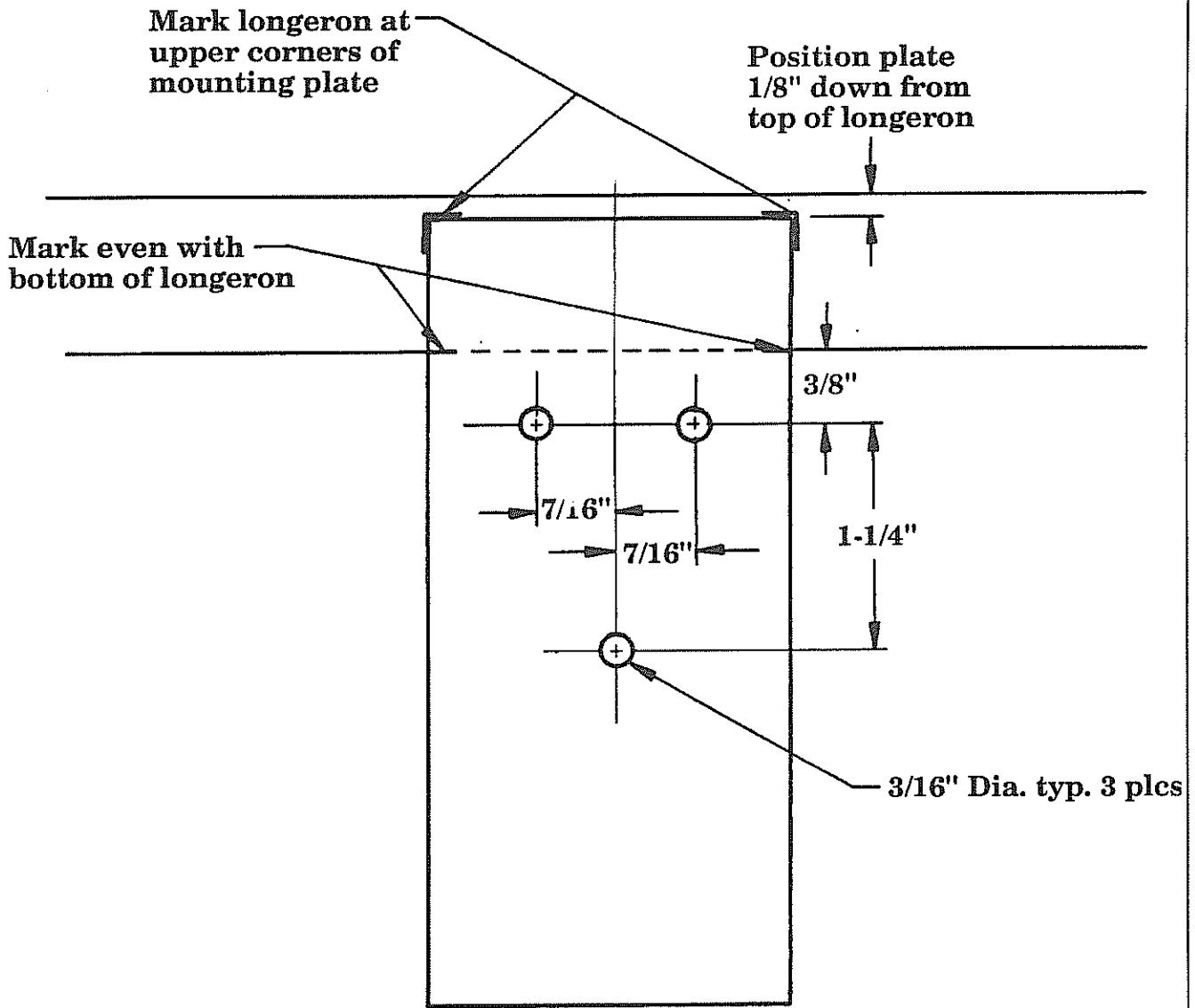

Fabricating strut bracket
 (STARBOARD SIDE SHOWN)
 Figure 17-28

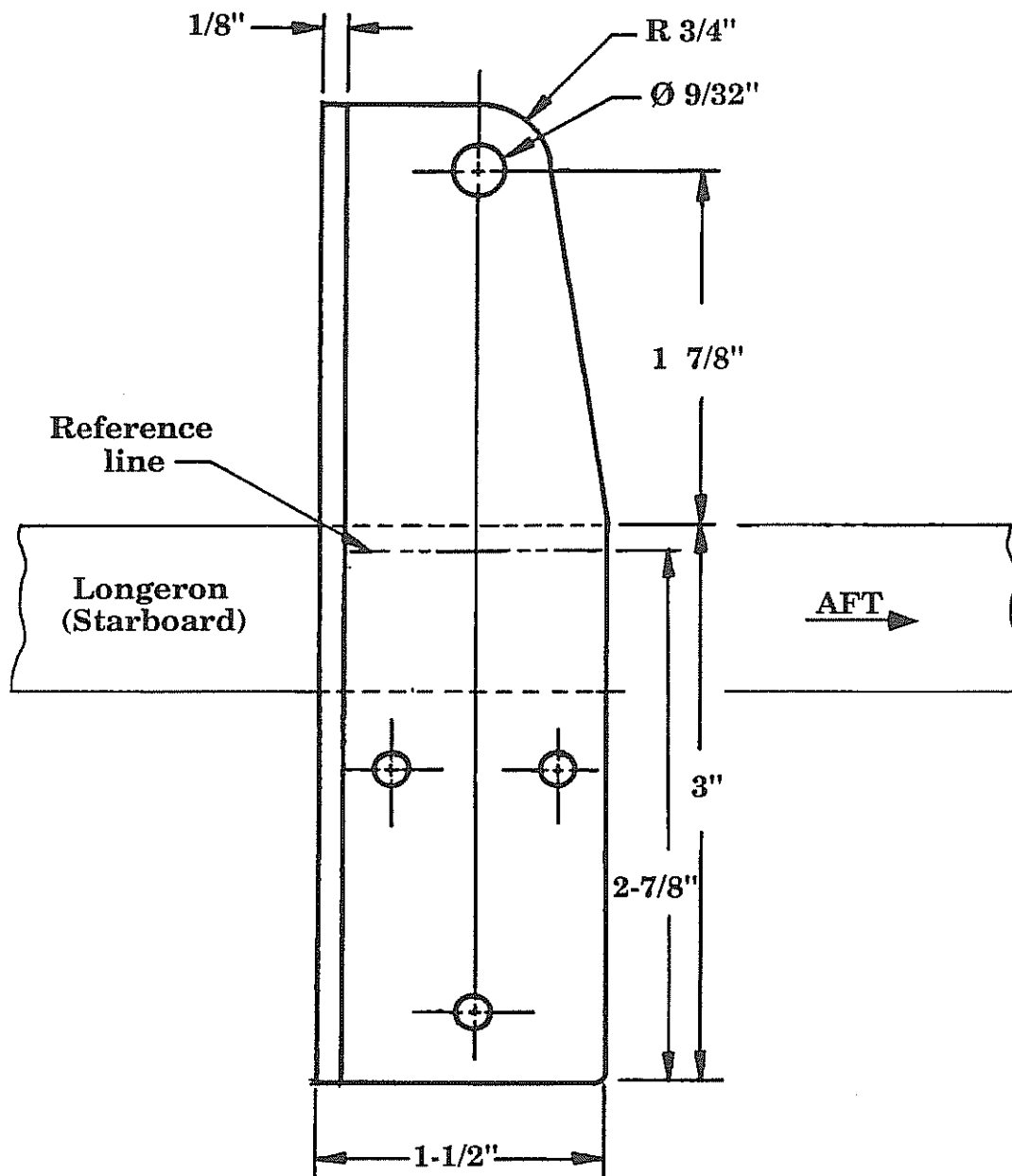

10. Mark a line up the center of the strut bracket as shown in figure 17-28. This line is in the center of the face, and disregards the web. Drill the $9/32"$ diameter hole $4\ 7/8"$ up from the bottom on this line as shown in blueprint "Q".

11. Measure up from the bottom edge of the bracket 2-7/8" as shown in figure 17-28 and mark a line across the bracket.
12. Place the top edge of the mounting plate flush with the line 2-7/8" up the strut bracket, and temporarily glue the parts together with four *small* dabs of instant or hot glue (see figure 17-29).

Drilling holes in strut bracket and mounting plate

Figure 17-29

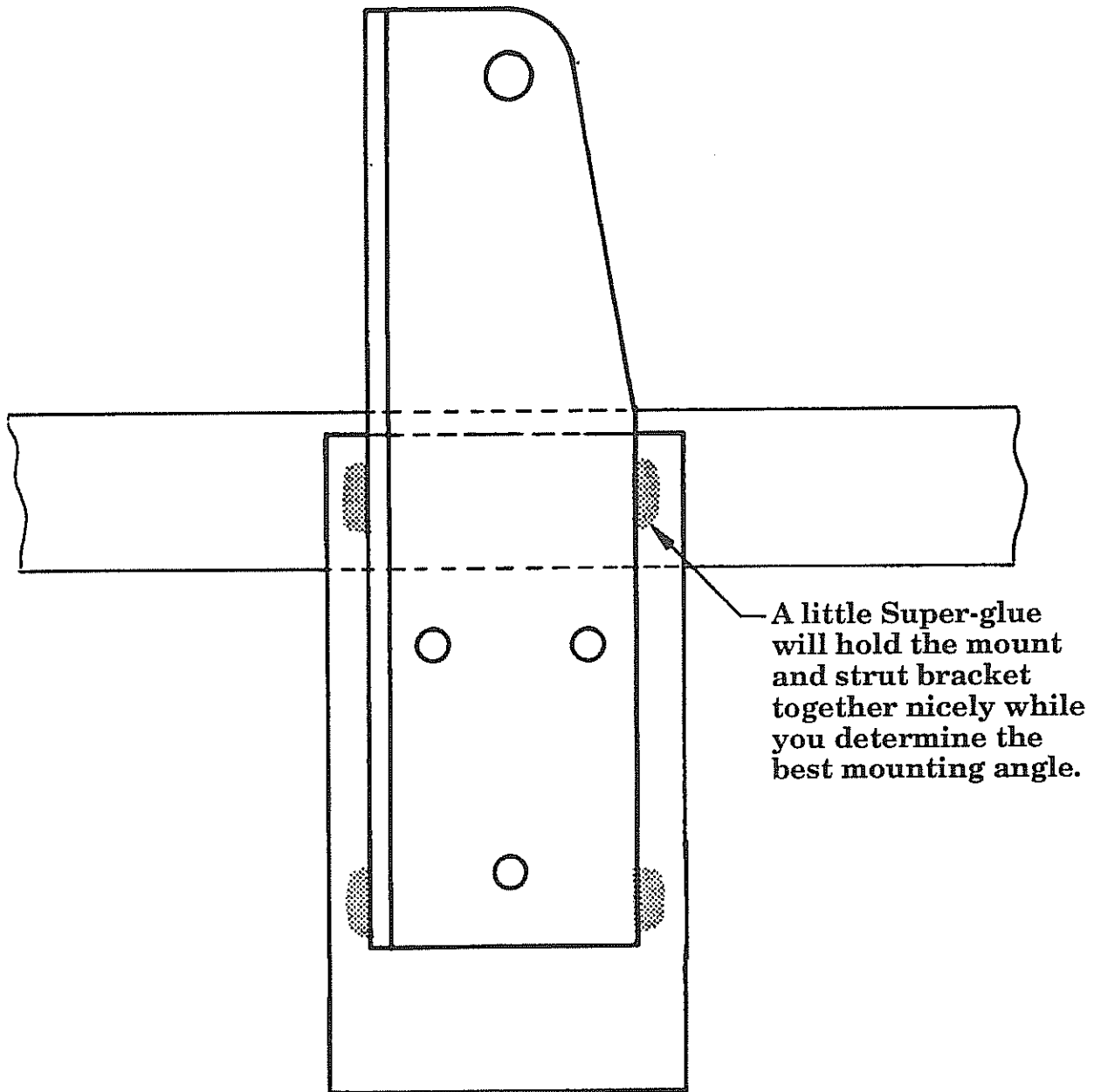

13. Using a 3/16" drill bit, drill through the marks on the mounting plate and through the strut bracket for the three mounting screws.
14. Carefully separate the strut bracket from the mounting plate. Using AN3-3A screws to hold them in place, install 3 K1000-3 nutplates to the back of each mounting plate, using AN426-A3 rivets, as shown in figure 17-30.

Installing nutplates on mounting plate

Figure 17-30

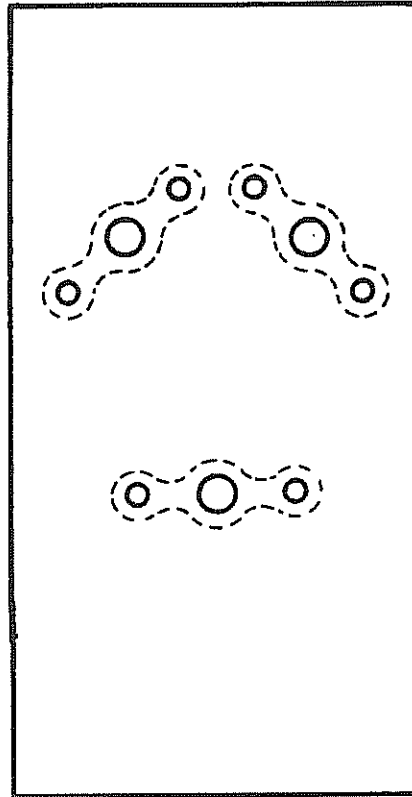

15. To simulate the 5 BID attach that will hold the mounting plate to the side of the fuselage, place 2 layers of duct tape on the outboard side of the strut bracket (the side that will go against the mounting plate).
16. Attach the strut bracket to the mounting plate using three (3) AN3-3A screws.
17. In order for the gas strut to have proper clearance, the bracket will have to be mounted at an angle, slanting inboard at the top. The strut mounting point will require about 1" of clearance between the bracket and the inside of the fuselage. To be sure that you have the proper clearance for the rod end, remove the rod end from the rod as shown in figure 17-31.

Be careful when removing the retainer clip from the rod - it can fly out and strike you in the eye, or get lost under the workbench or out in the grass or wherever it is those things end up that are never seen again. Keep your finger over it so it doesn't get away.

Removing/installing retainer clip in rod end

Figure 17-31

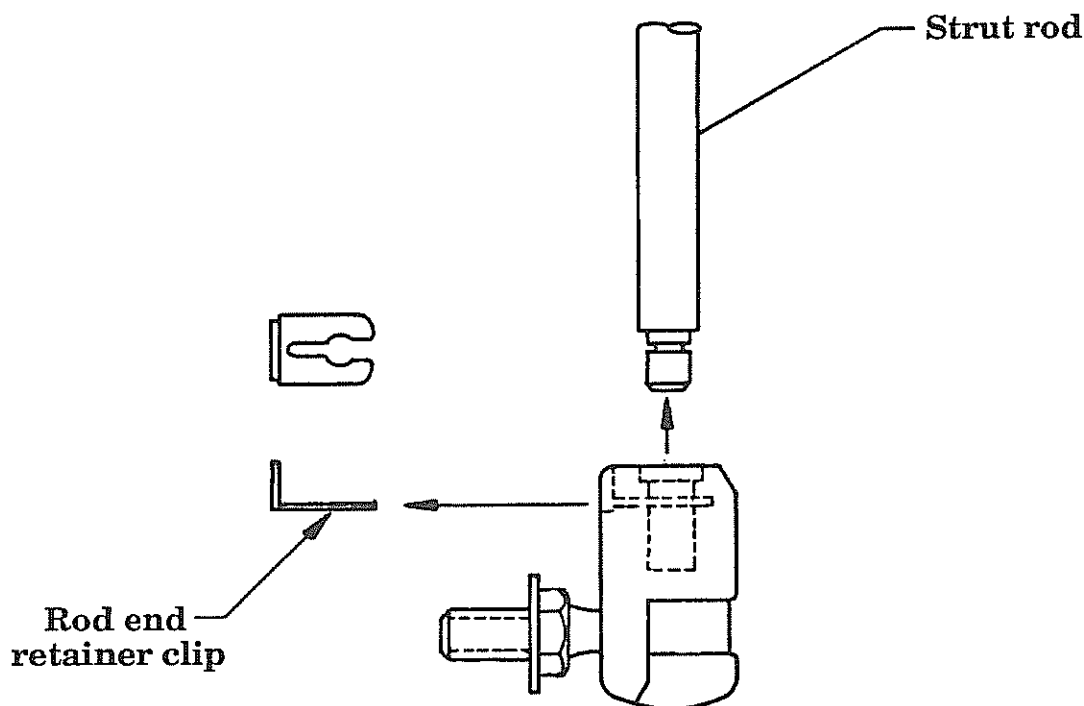

18. Bolt the rod end into the 9/32" hole in the support bracket so that the rod end is on the outboard side of the bracket. To insure proper clearance when you are measuring, wrap four layers of duct tape around the rod end. The end can now rest against the fwd deck, and you know you will have the necessary clearance.
19. Refer to figure 17-32. Place the mounting plate in position on the longeron so that the 9/32" hole center is 1-7/8" above the top of the longeron, and the duct tape on the rod end is just touching the inside of the forward deck. The mounting plate will not touch the longeron, but be held away from it by the bottom resting against the fuselage inner surface. A spacer must now be made for the longeron that will stand the bracket this distance away, and a foam block must be shaped to fill the gap between the mount and the fuselage (see figure 17-32). If you are short the extra hands to hold the mounting plate in place and measure the gap, a couple small dabs of super glue will come in real handy to hold the mount in place while you measure.

Locating strut bracket

Figure 17-32

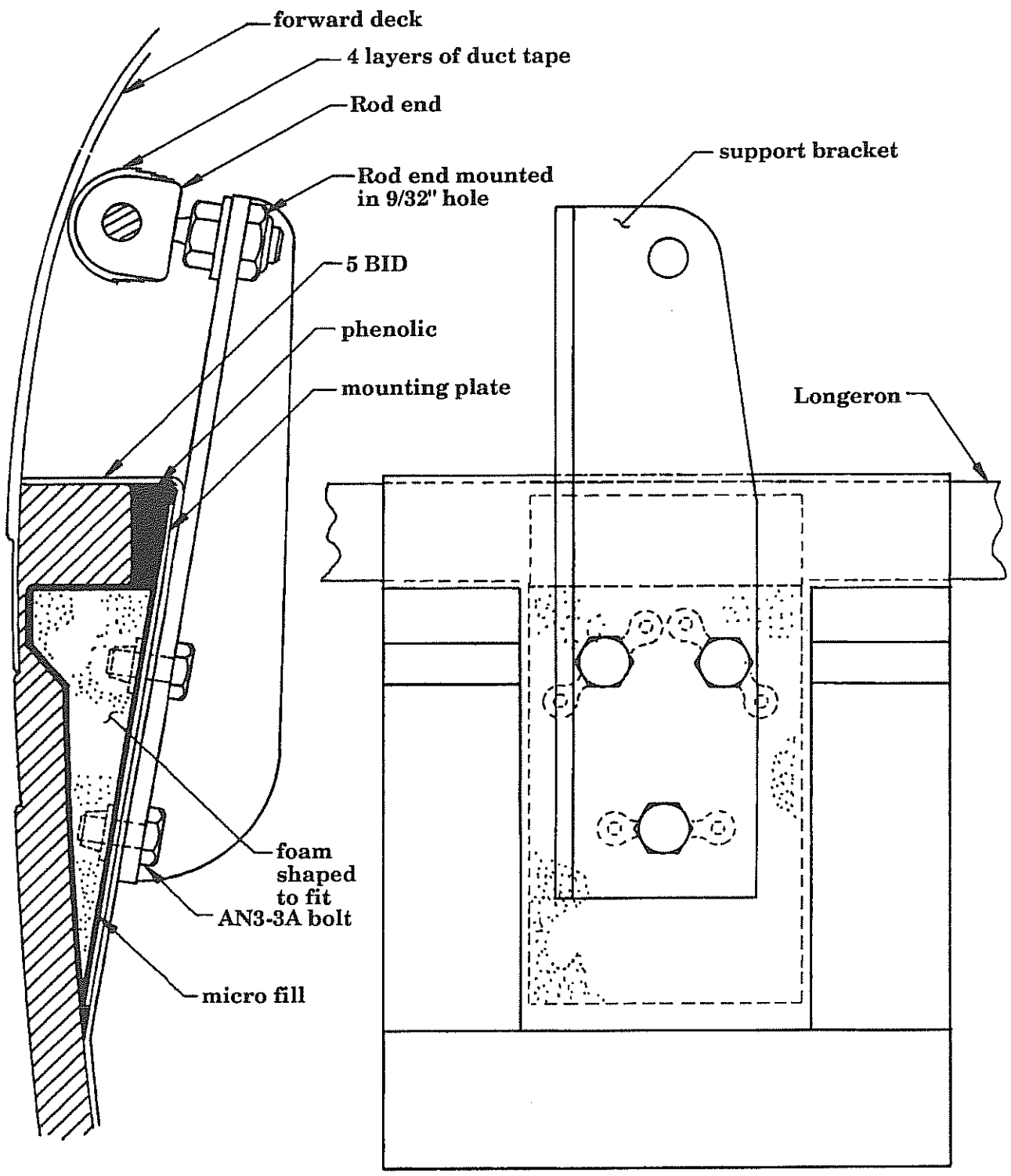

20. Shape a foam block as shown in figure 17-32 to fit between the mounting plate and the fuselage.
21. Shape another spacer from either foam or phenolic to go between the mounting plate and the longeron.
22. Pop the mounting plate loose from the fuselage and put a layer of duct tape on the outboard side of the mounting plate, covering the plate and the nutplates and bolts protruding from the outboard side.
23. Using epoxy/micro, glue the foam blocks into position and place the mounting block into position over them, making sure they space the mounting plate out properly. You will, of course, have to notch out some of the foam to make room for the nut plates and bolts sticking through the mounting plate.
24. When you are sure it is properly positioned and correctly spaced, remove the duct tape, put a little grease around the bolt threads and the nut plates where the bolt threads protrude and, using epoxy/micro, glue the mounting plate into position with the bracket and rod end installed. You can use a little more superglue as you did before to hold the bracket in place until everything sets up.
25. Use a little more epoxy/micro to fill in any gaps and to make a nice small fillet where the 5 BID will be placed over the mounting plate, longeron, fuselage and foam spacers.
26. Remove the screws holding the bracket to the mounting plate and remove the bracket and rod end.
27. Lay 5 BID over the mounting plate as shown in figure 17-32, extending it onto the top of the longeron and an inch in all directions.
28. After it has been applied, you can carefully work a pointed object such as a sharp pencil or knife point into the three bolt holes, enlarging them so the bolt can fit later. After the BID sets up, a quick hit with a sanding block will return the spots to a nice flat surface.
29. Re-install the brackets, with the gas struts attached. We will need them over the next few steps to be sure that we leave clearance for them. It might be a good idea to tape a clear plastic bag over them to keep them spiffy.



D. Canopy frame

1. Since you have already established the fwd deck location, cleco it in place as shown in figure 17-35.
2. In order to have the canopy frame maintain the proper shape, and still be able to work on it, a brace for it must be constructed. Get two pieces of plywood or equiv. and make a contour pattern of the fwd deck at the junction of the canopy frame and also a pattern of the rear roll over. These do not have to be accurate at all, just pencil them in by placing the piece of plywood on the longerons and by laying a pencil flat on the decks, trace off the contour line all the way down to the longerons. These pieces of wood should be about 6" wider than the fuselage at their relative positions so that they hang over the longerons by 3" per side. They will be used later to make a quick and simple jig to hold the canopy frame when you remove it from the fuselage. By making sure that the wood is level, it will be easy to sit the frame upside down later without it "walking around" when you're working on it. See figure 17-34. Set the wood aside.

Canopy frame assembly
EXPLODED VIEW
Figure 17-33

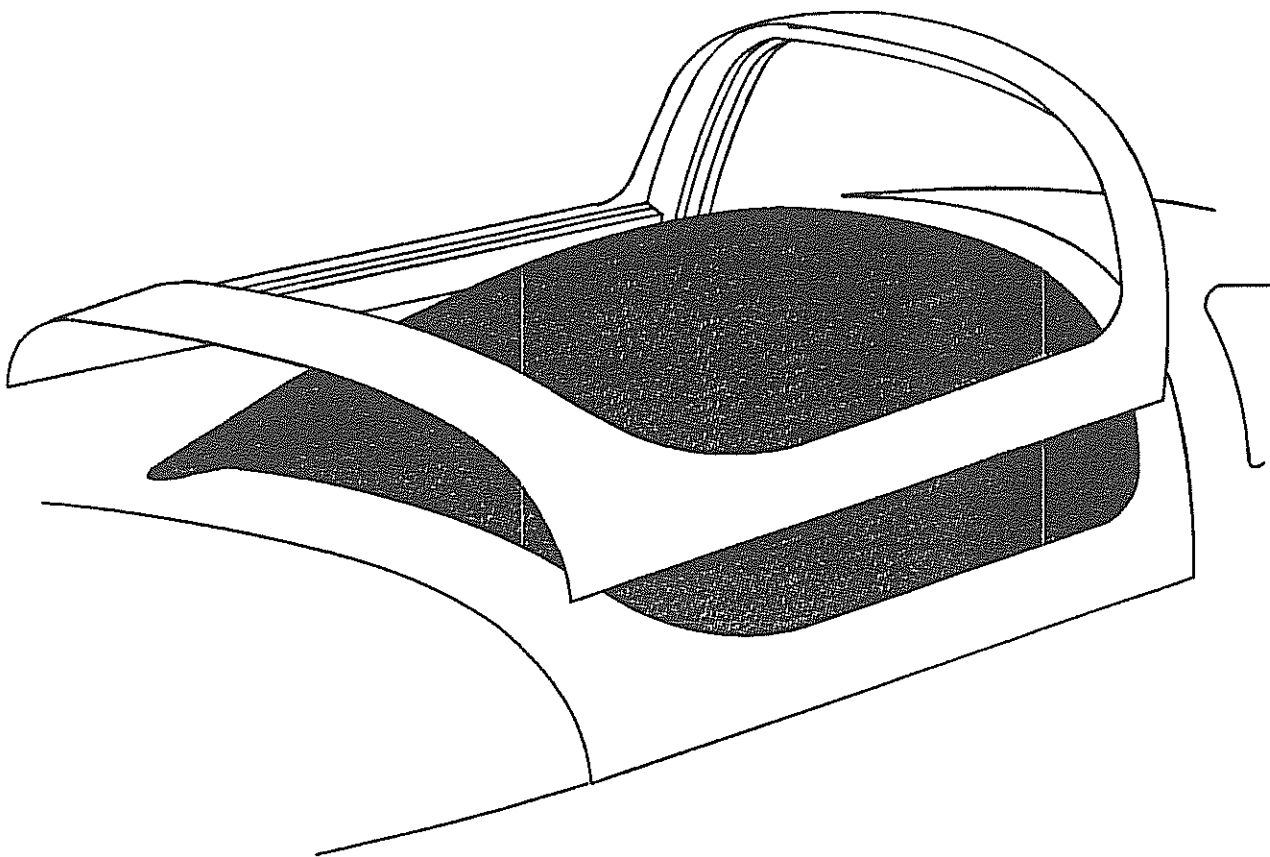

TRACING PATTERN for CANOPY BRACES

Figure 17-34

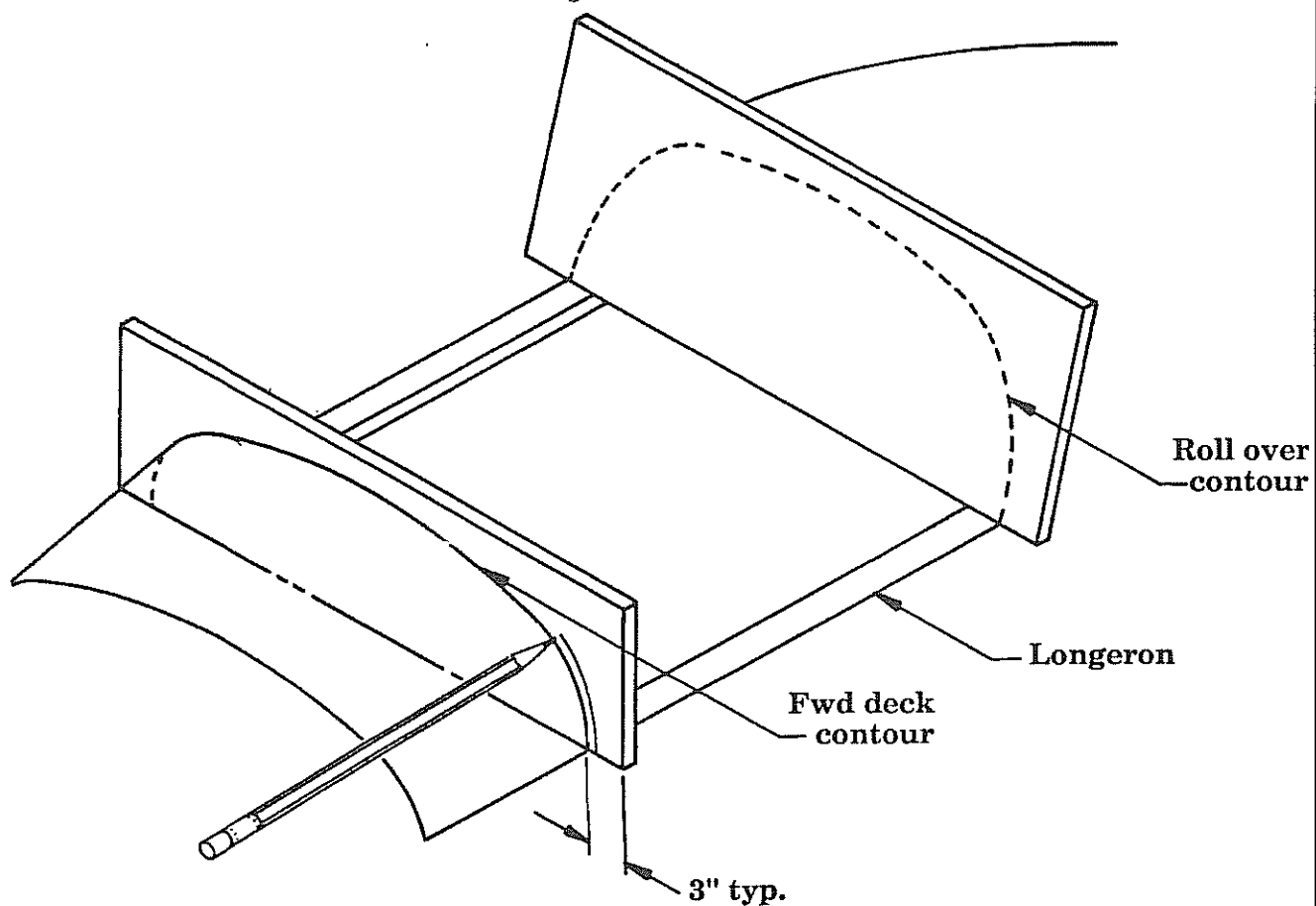

3. Lay the canopy frame over the airframe in relative position. Check for side rail alignment, the frame sides will eventually have approximately $1/8'' - 3/16''$ clearance from the top of the longerons. This is to allow for a "P" strip seal or equiv. See figure 17-35.

4. Locate the frame in a fwd/aft orientation that places it at a point which allows for complete coverage of both the fwd deck joggle and the aft roll over joggle. The frame has been factory trimmed to mate with these joggles. If at all possible, it is generally best to orientate the frame as far fwd as possible, this will provide additional instrument room since the distance from canopy to panel would be at its maximum potential. Trim and sand as necessary to establish an alignment with the L.E. of the fwd deck joggle and alignment with the T.E. of the aft roll over joggle.

NOTE: It is recommended that before you trim any of the material on the sides of the frame, first be sure that the frame is flushed up with the surfaces of the fwd deck and aft deck. The joggle may be initially too deep so use short pieces of mixing sticks to shim the frame up to a flush condition. Use dabs of hot or instant glue to hold these shims in temporary position as shown in figure 17-35. Also, review both canopy seal methods prior to trimming frame sides, as the alternate method benefits from this extra material.

NOTE: Do not trim the inside of the frame (where the canopy will install) until you have laid the canopy itself over and verified dimensions. You'll want to establish at least 5/8" overlap on all areas except for the front curved area where the overlap can be a little less. (The canopy will be bonded to the inside of the frame but you can verify dimensions by fitting it over the top initially.)

Canopy frame taped in position

Figure 17-35

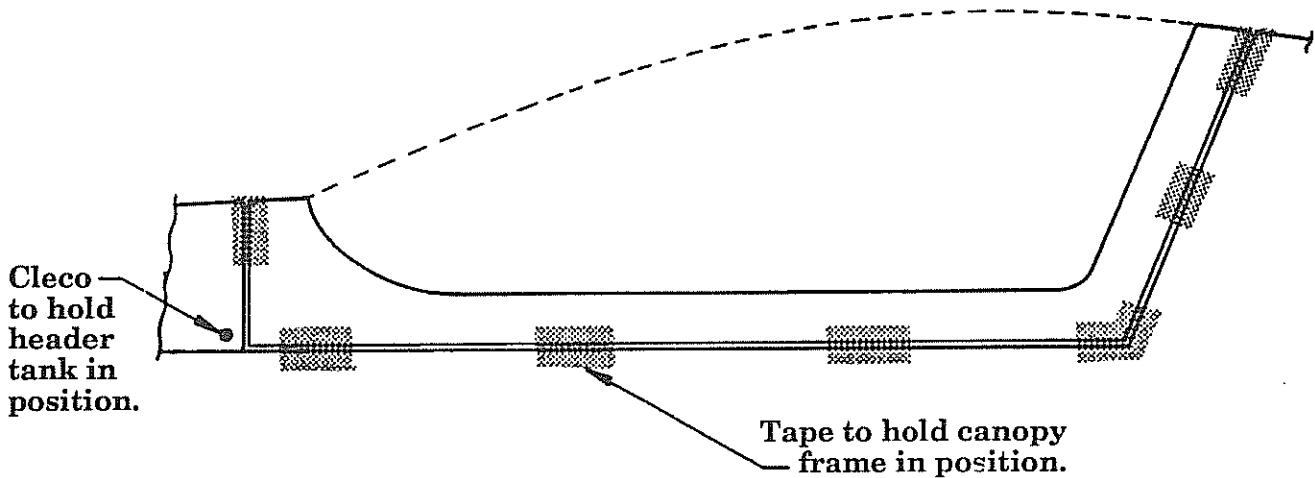

5. With the canopy frame fitted into the joggles you are ready to trim the lower edges as necessary to accurately match the frame side profile to the fuselage sides. By using mixing sticks and hot or instant glue, and cutting and sanding as necessary, position the canopy frame so that it is flush with the fuselage profile, with about 1/8" gap between the frame sides and the longerons, even fore & aft and on both sides. Either sand this to a smooth line now, or mark it well and sand it later after you install the bracing and remove the canopy frame for other steps.

NOTE: There are three different latch mechanisms described in this chapter, each system requiring canopy frame hardpoints in a different location. At this time you should review the different systems. The system we use on the standard opening canopy is fine, and requires only the aft latches, the installation of which begins on page 17-65. The second method is shown on page 17-75, a draw bolt style. This is a very simple system that you can do the "finish" design of, based on your seat location, etc., and will require a couple of hard points on each side of the frame. The third method is described on page 17-76, and is a very nice lever-style latch that works very well, but requires a bit more work. Please read all three installations first and then determine which system is to be your choice. After you have made your decision, proceed with step 6., below.

6. Referring to the dimensions given for the latch system you have chosen to install, carefully lay out the hard point positions by marking their lines onto the fslg sides. Draw a line that crosses the longerons vertically and thus provides position marking reference on both the canopy frame (inside and outside) and the fslg. Label them as "aft canopy lock", "latch", etc. (This can become confusing later so some simple labeling now will eliminate some later head scratching.) Also mark the area that foam will need to be removed from to make clearance for the hard points.
7. Measure from the center of the fuselage strut attach point aft 12-5/16" to a point 1 1/4" above each longeron (Refer to blueprint "Q"), and mark this spot on the inside and outside of your canopy frame. This will be the center for a phenolic hard point later.
8. Now that the exterior of the canopy is the exact shape we want it to be, and we have all of the hard point locations marked off, we need to construct a brace to hold it in that position while we do some extensive modifying on the inside. Using a sabre or jig saw, cut out the pieces you marked earlier, so that you have a silhouette that is slightly larger than the canopy frame itself. Don't bother trying to get it even close, Bondo will take care of that.
9. Sand the braces to remove any splinters that would get you later, and wipe the inside edge of the patterns with acetone or MC to clean them for the next step.

10. Referring to figure 17-36, mix up a big hot (lots of hardener) gob of Bondo, spread it along the forward part of the canopy frame from one side to the other, in spots about 2" long and a half inch deep. Squish the forward brace piece down into position, wiggling it a bit to get it down to the frame through the Bondo. Check that the top line of the board is level side to side (so it will be able to rest upside down) and true vertical (so it won't fold under when there is weight on it) and hold it for about 5 minutes while the Bondo cures enough to hold its position. Repeat this process for the aft brace.

Canopy frame brace

Figure 17-36

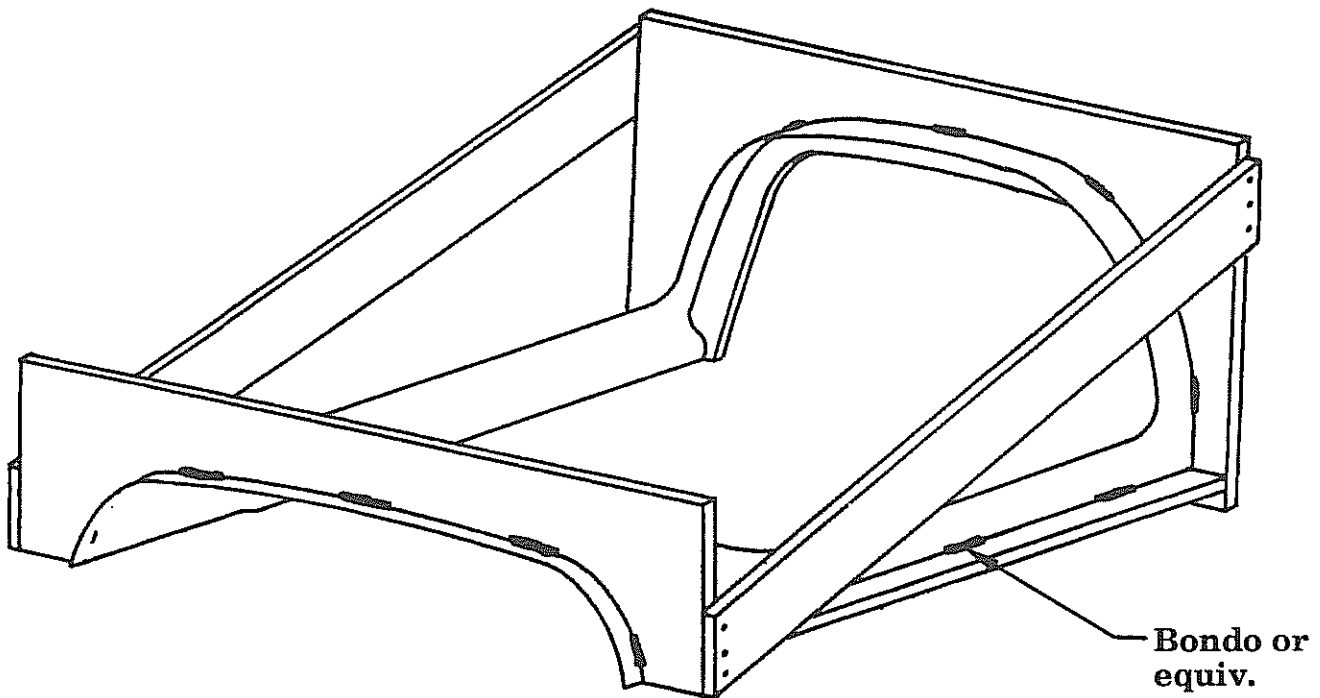

11. Nail, screw or glue a couple of pieces of wood as shown in figure 17-36 between the two braces to make them a more rigid structure. Then use some more Bondo to put a couple of fore-aft braces down the sides of the frame, bedding the wood as you did in step 6, and then screw or nail it to the front and back braces. **BE SURE NOT TO DISTORT YOUR CANOPY FRAME WHEN YOU DO THIS -** When you are finished with the next steps, if you have distorted it here, the distortions will be permanent!

Later on, when you are finished with the frame, you can simply knock the boards off with a good smack of a hammer.

12. Referring to the appropriate data for the latching system you have selected, cut the necessary pieces of aluminum for the hard points. These will be potted into the canopy frame.

13. You will need to remove material from the front of the side stiffener for clearance for the gas strut. Holding the strut up to the frame, mark the area you will need to remove for it's clearance. Remember, the strut is fully extended now, but when installed it will be fully collapsed when the canopy is down, so only mark out the area you will need for the body in the collapsed position.
14. Remove the canopy frame and bracing from the fslg and place it inverted on a bench or on the floor. Sand a smooth line onto the bottom of the rails to create a finished line for the side rails, if you haven't done so already.

NOTE: The existing forward stiffener in your canopy frame is not stiff enough to handle the hinge pressure of the forward opening canopy. It will have to be removed and replaced with a stronger one. Also, the stiffeners in the canopy side rails are, for the forward opening canopy, much thicker than they need to be. They can be cut back, giving you a little more "elbow room" in the cockpit later. If you want the extra room, now is a good time to go for it. The side rail stiffeners in your canopy frame can be cut back until they are the same width as your longerons. While you are cutting away the forward stiffener, remove any excess width from the side stiffeners as well.

15. Cut around the forward stiffener and remove the covering BID.
16. Using the existing stiffener as a pattern, cut another one from 1/4" white foam, and set it aside until you get to step 21, below.
17. Chisel or grind away the exposed foam stiffener, being careful not to go into the glass beneath it.
18. If you want the extra space, cut away the side rail stiffeners as discussed above.
19. The remainder of the BID that held the old forward stiffener in place should be sanded away until you have a fairly smooth area to work with. It isn't necessary to remove all of the BID that held the stiffener, but at least smooth it down.
20. Remove the excess material from the canopy side for clearance of the gas strut.
21. Referring to "Q", cut a 1/4" thick white foam stiffener to wrap around the L.E. area of the canopy frame. This stiffener must stop short of the overlap where the frame rests on the fwd deck joggle. It can roll most of the way down the fwd sides (leaving room for the gas strut!), getting a little wider as it moves down the sides. Also, keep it back from where the canopy will lay against the inside of the frame (Keep about an inch or so of clearance). Sand a large bevel onto the stiffener so that it does not interfere with the instrument panel dust cover. This bevel should be along the fwd side of the stiffener. Also sand the edges to a smooth transition into the frame so the unidirectional graphite fabric (UDG) will lay up easily.



NOTE: The following steps are performed using **UNIDIRECTIONAL GRAPHITE FABRIC (UDG)**. Drawing "Q" shows how many *total* plies go where. The method, though, is to put on half the plies indicated, put in a foam stiffener, then lay up the rest of the plies. When making these lay ups, it is best to do them without waiting for the previous layer to harden. If A layer sets up before you begin applying the next one, you will have to stop and wait until it is hard enough to rough up, so that the next layer can properly adhere.

22. Refer to Dwg "Q" and figure 17-37. Using #40 grit, rough up the area shown (just enough to make a good mounting surface - you don't need to remove any material) and then clean area with acetone or MC.
23. Lay up 4 plies of UDG in the direction and area shown as "8 ply carbon".
24. Lay up 1 ply of UDG in the area shown as "10 ply total carbon f. full width".
25. Lay up 2 plies of UDG in the area shown as "(32") 14 ply total carbon f."
26. Lay up 2 plies of UDG in the area shown as "(20") 18 ply total carbon f."
27. Use micro to attach the stiffener you made in step 21 to the inside of the canopy frame. Use weights to hold it until it cures.
28. Apply a thin layer of micro over the foam stiffener to seal the foam pores.
29. Lay up 2 plies of UDG in the area shown as "(20") 18 ply - -".
30. Lay up 2 plies of UDG in the area shown as "(32") - 14 ply - -".
31. Lay up 1 ply of UDG in the area shown as "10 ply total - -".
32. Lay up 4 plies of UDG across the area shown in fig. 17-37.
33. Let cure.



CANOPY STIFFENING

FIGURE 17-37

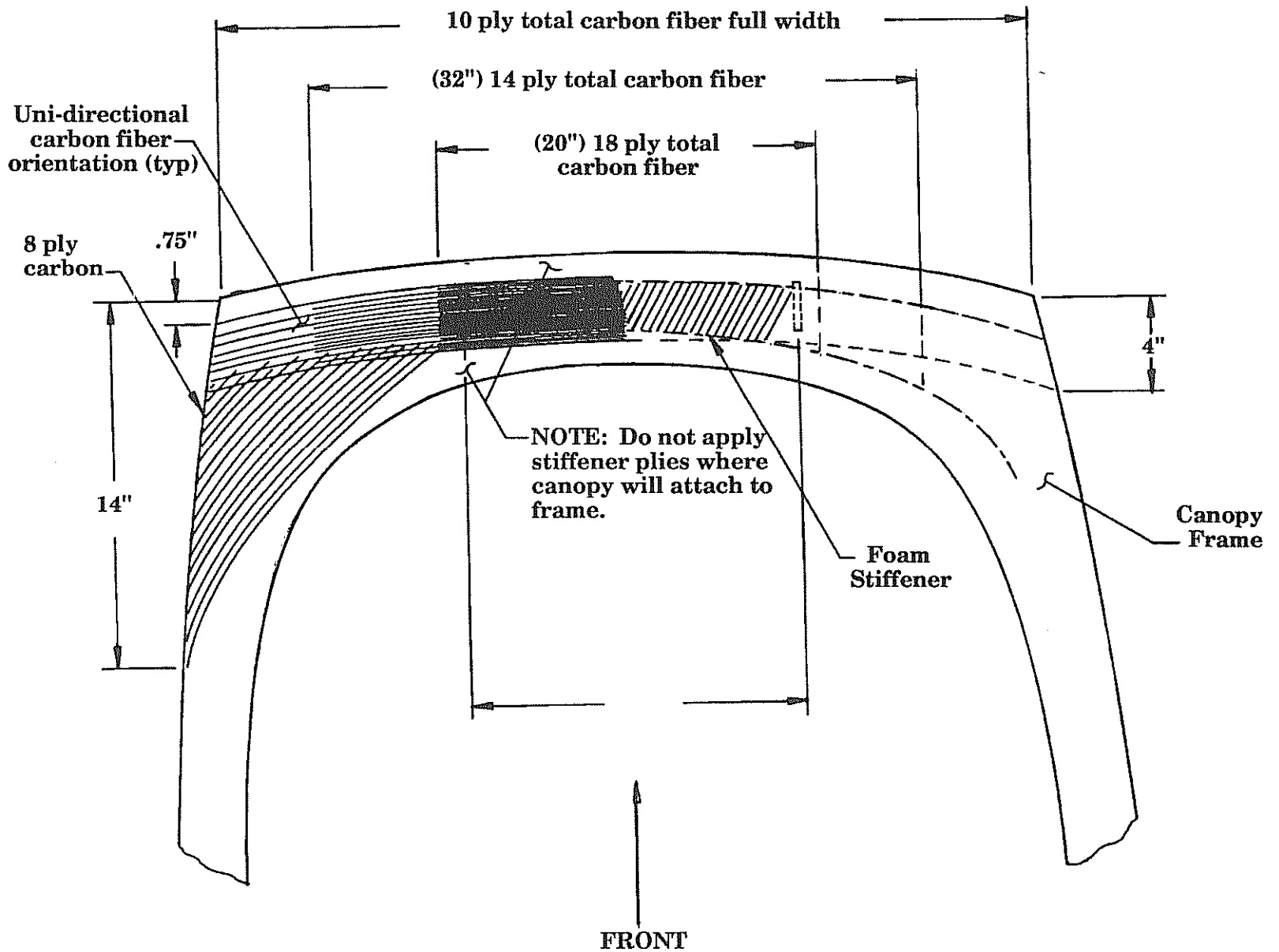

34. Referring back to the mark you made in step 7 above, for the canopy strut hard points, prepare two pieces of phenolic about 1 1/8" square and 1/4" thick. Bevel the sides so the attaching lay-ups can smoothly cover them.
35. Drill and tap a 5/16-18 hole in the center of the phenolic pieces.
36. Remove the captive washers from the two remaining strut attach ball studs, and grind the threaded end off until, when threaded into the phenolic blocks, no portion of the threads sticks out the back.
37. Mix up enough structural adhesive for the next two steps.
38. Lightly coat the ball stud threads with structural adhesive, and put enough adhesive into the threaded hole in the phenolic blocks to make a good bond. Screw the ball studs tightly into the blocks.
39. Coat the back of the blocks with sufficient adhesive and position them onto the canopy frame, clamping them in place (tight, but not too tight!) until they cure.



E. Side rail stiffeners

Note: You will want the bottom of the frame side rail to be at least 1/8" wider than the seal strip you will use. If you are using the inflatable "D" strip we use on our plane, you will need to make the side rail about 11/16" wide. This procedure covers our choice, using the "D" inflatable seal. Now is a good time to consider what type of seal and sealing system you are going to use, because it will have to be provided for here. Study the following steps, and review the alternative method shown on pages 17-69 through 17-74, until you are sure about the seal system you will use.

1. Cover the longerons, and anything else in the immediate area of where the canopy frame will mount, with plastic. You may "dribble" in the next few steps, and an ounce of plastic prevention is worth an hour of sanding cure later.
2. Place the canopy back onto the fuselage, still in the support frame.

NOTE: On the Fwd hinge canopy system, you can reduce the width of the side rails to that of the longerons.

3. Sand a smooth finish (you may have to fill in spots with the micro first) on the side rail foam. Sand them down with a small 6" block sander and some #50 grit paper. Sand down to be flush with the inside of the longerons along the area of the side rails. Remember the clearance for the gas struts, using a little creative sculpting you can neatly "fair in" the gas strut, see figure 17-38.
4. Cover the foam side rails with micro (just enough to fill in the pores in the foam only) and lay up 3 BID over the top. Contact at least 1" onto the frame prepreg and roll over in the back. Trim the 3 BID so that it just extends a little past the bottom and hangs there for now. If you have more than about a half inch hanging over it will possibly put some waves in the finished part so trim it that close for initial layup. Let it cure.
5. Remove the canopy frame from the fuselage and place it inverted on the floor or workbench. Sand a smooth line onto the bottom of the rails to create a finished line for the side rails.



FAIRING IN THE GAS STRUTS

Figure 17-38

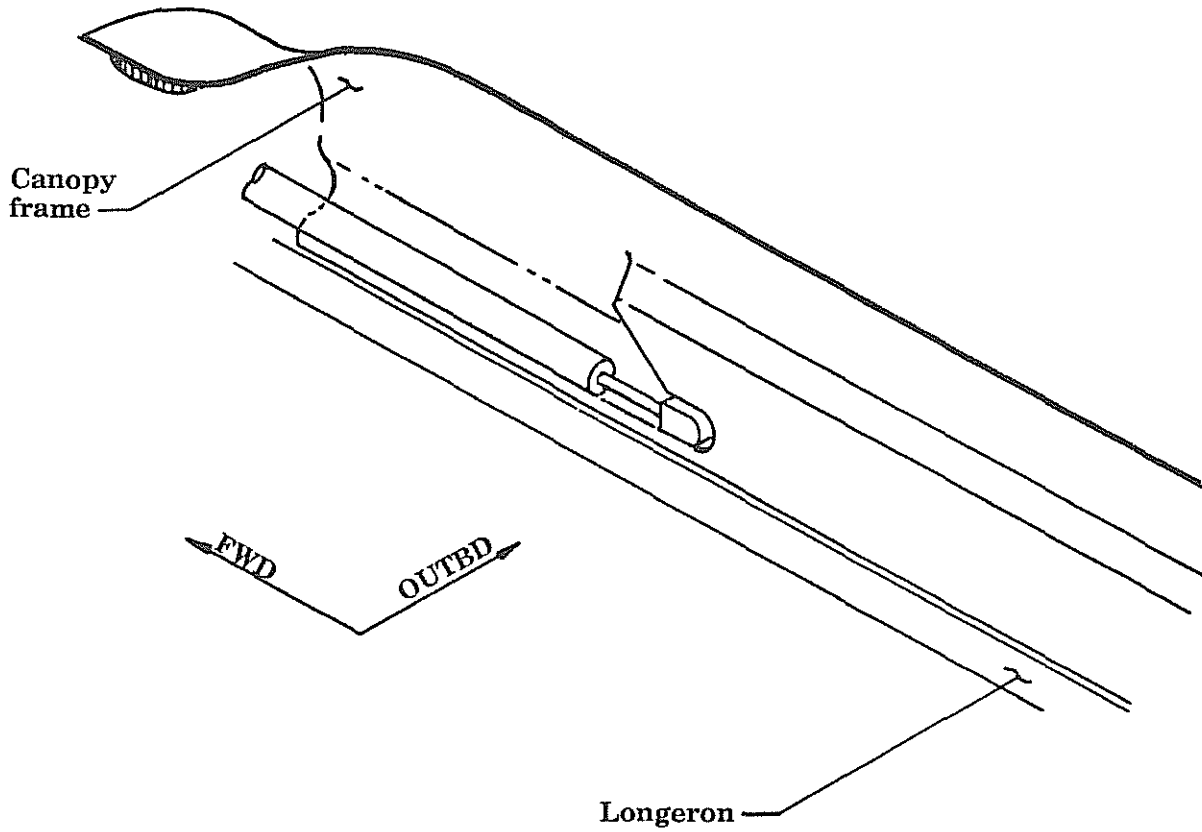

F. Canopy Hinge Installation

NOTE: At this time, you should have the header tank installed, with the 8 BID stiffeners installed in the pockets.

1. With the header tank mounted and the canopy frame off of the fuselage, refer to Dwg "Q". The header portion of the hinge is centered exactly 8" from the centerline of the aircraft. Using #50 grit sand paper, scuff the inside of the pockets in the area where the hinges are to be mounted, and make a vertical line through the pocket at the 8" point.
2. Center the LS 3 bearing in the small end of the two curved .250" brackets.
3. Using freezer or plastic tape and an Xacto knife, build up the surface around the bearing bushing until it is thick enough that, when it is bolted between the two pieces of tank bracket, it holds the two brackets together tightly, with the bearing shoulders just touching the two hinge halves. They should be tight enough so that they remain at any angle you set them.
4. Using #50 grit paper, rough up the area of the brackets that will later be bonded.
5. Cut a piece of 2x4 wood so that it is 15 3/4" long, with the ends **flat and square to each other**.
6. Lay the wood on a **flat** surface.
7. With the bracket ends flat on the surface, clamp or hot or instant glue them onto the ends of the 2x4.
8. Make sure the header tank brackets are vertical, 90° to the flat surface (remember, the assembly is now upside down).

NOTE: IT IS IMPORTANT to mount the hinges as high as possible in the header tank pocket so that you will have the maximum canopy travel, and the canopy to fwd deck transition will be as smooth as possible. The lower the hinge mounting point, the more you will have to bevel the edges of the canopy and fwd deck later.

9. To make this easier, find something that you can put inside the cockpit that you can use to prop up and hold the hinge/2x4 assembly in position while the adhesive is curing. **CLEAN THE BRACKETS WITH ACETONE OR MC.** Using structural adhesive, coat the mounting surface of the hinges and, turning the assembly right side up, bond it to the header tank. Remember, get the hinges as high as possible in the pocket, but **KEEP THE HINGES LEVEL TO THE AIRCRAFT.**



10. Clamp in place, wipe away any excess adhesive and wait until the adhesive has had sufficient time to cure.
11. Per Dwg. "Q", fill the bracket holes with floc, and the gap at the top of the bracket with micro. **Do not remove the tape from the bearing area yet.**
12. Finish the header tank portion of this procedure by laying the 6 BID attach over the brackets, being careful to not get any epoxy into the workings of the hinges.
13. After cure time, carefully remove the 2X4 and clean off any residue that may be left on the hinge bracket from the hot or instant glue, and apply plastic release tape to the area where it will attach to the canopy.
14. Carefully rough up the surface on the canopy frame where the hinge will attach (see dwg. "Q").
15. Place the canopy frame in position on the fuselage.
16. Raise the bracket arms up until they touch the canopy.
17. Following the pattern shown on drawing "Q", lay up first the 4 BID areas, then the four additional BID, then the final 6 BID, each layer going up the sides of the bracket arm about 2".
18. After everything has had time to cure, and without disturbing the position of the arms or the canopy, drill the two holes in each bracket, through the fiberglass, as indicated.
19. You can now unbolt the brackets from the header tank and remove the canopy. Remove the arms from the canopy, one at a time, and mark them so you will know which is left & right.
20. With the canopy upside down, fill the void area inside the brackets, between the bracket arms and the canopy, with solid micro/floc to stiffen the radius area of the 14 BID fiberglass fittings. Re-insert the arms (with their plastic release tape still on them) into their respective holes until they are in proper position, and wipe off any excess epoxy that is squeezed out.
21. After the epoxy/floc has set, remove the bracket arms.
22. Remove the tape from their ends and clean the brackets.
23. You can now proceed with mounting the lock and latches.





G. Canopy plexiglass installation

NOTE: DO NOT REMOVE THE PROTECTIVE COATING FROM THE CANOPY UNTIL INSTRUCTED TO DO SO!

1. With the canopy frame upside down on the bench, **STILL IN ITS BRACE**, lay the canopy into it. Adjust it from left to right and fwd to aft until a good fit is established. Note the areas of overlap. You should have about 5/8" minimum around all sides with less around the front curvature.
2. Trim the canopy frame and sand the edges smooth. This will NOT be a finished paint line but it will determine that line to some degree. The actual finished paint line will be inside of the trim line by approximately 1/4".
3. Prior to bonding the canopy into the frame, sand a gradual bevel onto the outside of the cutout, this will help the transition during "finishing" later.
4. Also sand and smooth the inside frame surface where the plexiglass will be attached.
5. Now place the canopy back into the frame (inverted) and run a felt tip marker around the outside of it to indicate on the plexiglass wrapping exactly where it will register back into the frame for bonding purposes. Transfer this line onto the inner side of the canopy protective coating as well.
6. Trim the canopy if necessary. Consult the recommended directions for canopy cutting produced by Airplane Plastics, which has been reproduced in this chapter in section 7, "Plexiglass Hints For Perfect Canopies".
7. Using a #30 bit, drill holes through the frame about every 6" around the entire perimeter of the canopy, directly adjacent to the edge of the plexiglass. These will be used for clecos which will serve as temporary clamps to hold the canopy in position during cure. Refer to figure 17-39.
8. Remove the canopy and peel back the protective coating, on the outside of the canopy, to a point beyond the felt marker line. Come back with plastic electrical tape (1/2" wide works best since it bends around contour lines easier) and remask the exposed canopy such that the tape line is just inside (by 1/8") the actual canopy frame line. You'll be able to see the reference line marked on the inner protective coating. Make sure there are no other exposed areas of the canopy showing. All little peeled spots on the protective coating (inside or outside) must be covered with a piece of tape.
9. Sand the exposed surface of the canopy with 50-80 grit sand paper.



CANOPY TO FRAME, CLECO MOUNTING
FWD EDGE
Figure 17-39

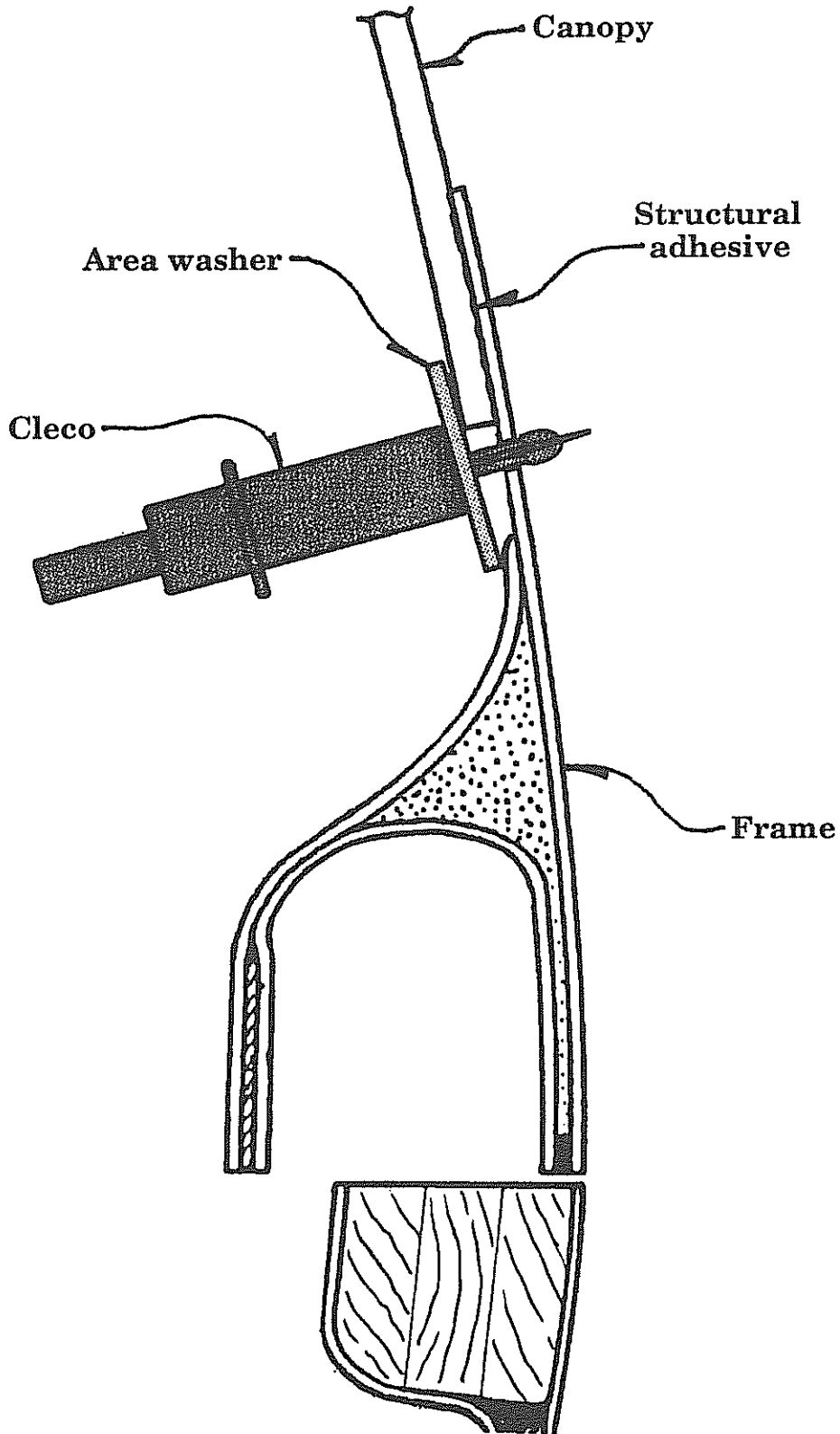

10. Mix up a batch of structural adhesive (with 5-10% flox added to thicken it up a bit) and spread a film on both the canopy and the frame.
11. With a little help from a friend, carefully place the canopy into position and set all the clecoes from the inside. It may be helpful to place an area washer over the cleco to attain a little more surface area on it while clamping however, it usually works quite well without these washers. If the clecoes have any tendency to slip off, then use the washers. As you set the clecoes, press down firmly on the canopy to squeeze out excess adhesive. Wipe this away as you proceed. You will generally be able to witness the bond area integrity by seeing the contact through the hazy (sanded) plexiglass. It turns darker when it has good adhesive contact. If you find that added pressure is needed in certain areas, just drill for a couple more clecoes.
12. When all the clecoes are set, carefully lift the unit off the bench and place it back onto the fslg to cure in the actual position. This is just a final safety measure to insure that you are not locking in any kind of twist in the canopy frame during this bonding process. With the canopy/frame positioned onto the fslg, wipe off any excess adhesive that squeezed out along the outside. Allow to cure at least 24 hours at room temperature.
13. Next, remove the canopy/frame and invert it back onto the bench top. Remove all the clecoes and clean away the protective coating from the inside. Peel it back about an inch and retape with plastic electrical tape to within 1/8" of the bond line. This bond line should be the same as on the other surface.
14. Sand with 50-80 grit and clean. The fwd area of the canopy will form a ridge where the glass extends down away from the frame. Sand the edge of the canopy slightly and fill the remaining area to form a micro fillet so the BID tapes will install properly. This will also help to stiffen the front end. See figure 17-11.
15. Add 2 BID all around the interior perimeter of the canopy. Overlap at least 1" onto the frame. On the side rails, extend the BID tape down 1" past the point where the channel begins to roll out. This is to add additional stiffening to that area. See figure 17-40.

At this time you may carefully beat the brace off of the canopy!



Canopy fairing

Figure 17-40

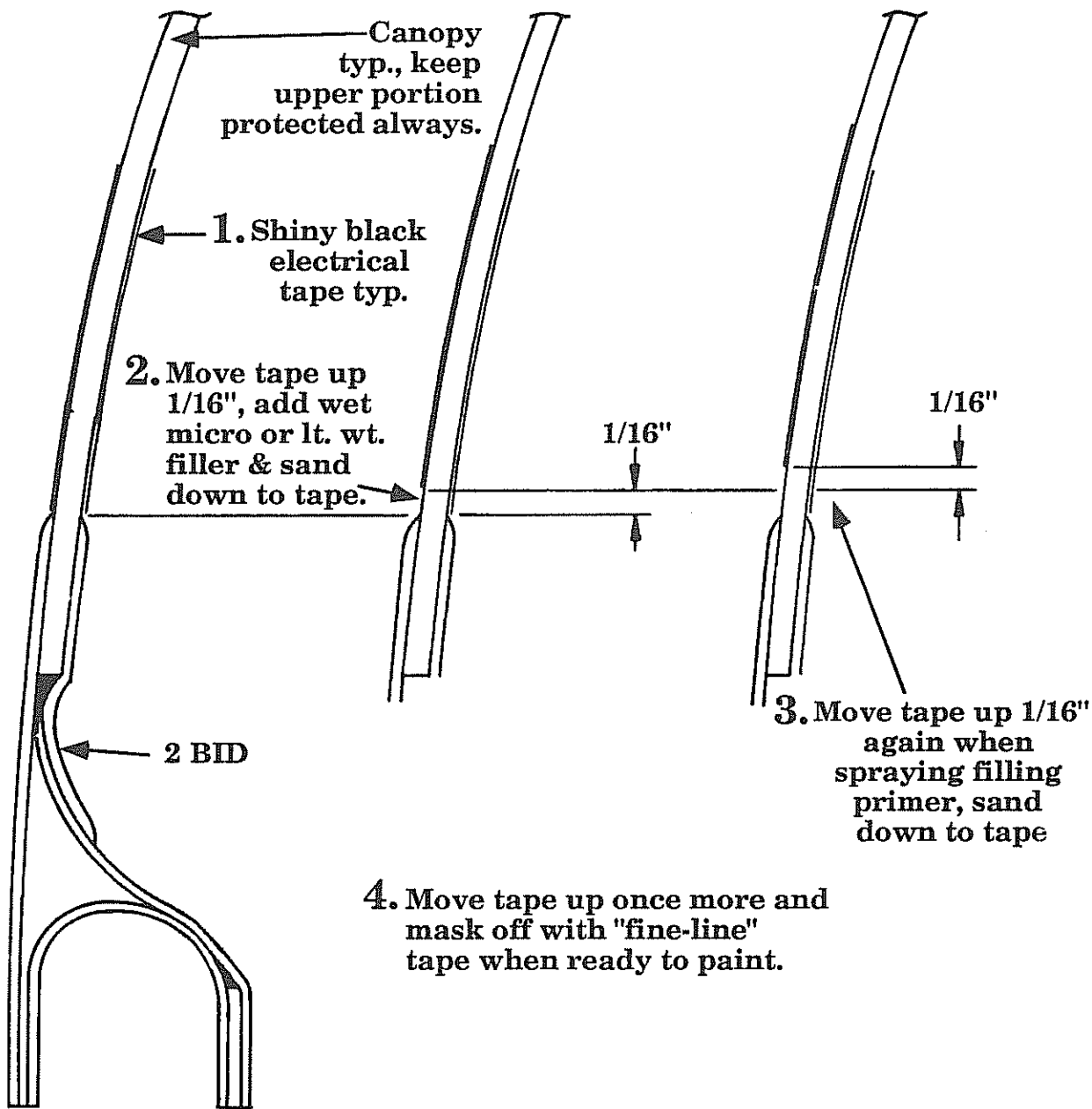

H. **Latch strike installation - STANDARD LATCH, fwd hinge canopy**

The standard in flight latch mechanism is a very straight forward installation using Cam-Loc® safety latches. These latches will pull over center for a positive lock with an additional safety catch to prevent accidental opening. These are each load rated at more than 4 times the required strength.

1. Decide where you want to put your latches - with this canopy opening configuration, we find that one on each side, just forward of the seat back, is just fine. Draw a vertical line that crosses the longerons and the canopy to provide a reference on both the canopy frame and fuselage representing the center of the latch positions of your choice.
2. Cut 2 pieces of .090" aluminum that are 2" long and 1-1/4" high. These will be potted into the inner sides of the frame where the latches will anchor.
3. Using a drill or Dremel tool with a router bit, remove the foam from the inside bottom of the side rails at the point you have chosen for your latches. You will need enough room to lay BID around the hard points, and the area will have to be completely free of foam for a good bond. See figure 17-41A and 17-41B.

NOTE: the hard points that will attach the latches will require the full elimination of foam against the aluminum inserts on the inboard side of the channel. For structural integrity, all foam must be removed from these areas, so the inner BID will attach directly to the aluminum inserts.

4. Once the channel is carved out for your hard points (fig. 17-41B), go in by hand with a piece of 36-50 grit sand paper and give it a final sanding to smooth everything up.
5. Using epoxy/micro (or preferably, structural adhesive), bond the hard points to the canopy frame (figure 17-41C), about 1/8" up from the bottom edge. Rough the aluminum up and clean it with acetone or MC immediately before bonding in place.
6. Lay 2 BID over the hard point (figure 17-41D) and let cure before proceeding to next step.
7. Position and mount the 'strike' for the latches by drilling two #19 holes through the strike as a guide and through the inbd side rails of the canopy frame. The strikes should be positioned even with the bottom of the side rail, see figure 17-41E).



Canopy latch striker installation
Figure 17-41

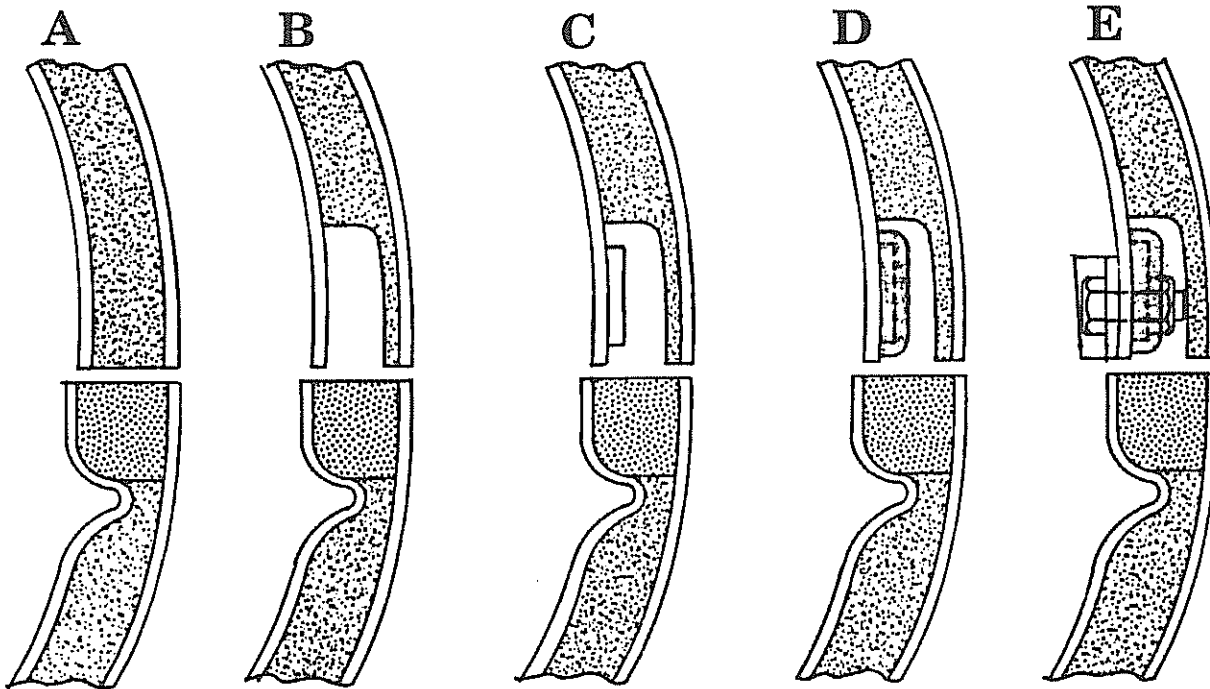

8. Next position the latch onto the strike and mark a reference position onto the sides of the fslg to show the location needed for the latch build up attachment block. See figure 17-42. Note the distance inbd from the fslg sides required for the latch when it is properly hooked on the strike. This will require the latch to be positioned off of the inner surface of the fslg skin.
9. Form a phenolic block that shims the latch out to the required position and orientation. Cut a smaller phenolic piece to fill the cavity under the longeron. This does not have to be a real snug fit, simply use epoxy / floc to pot this in and fill any little voids. See figure 17-42.

AFT LATCH, typ.
Figure 17-42

5121-1X1AA →

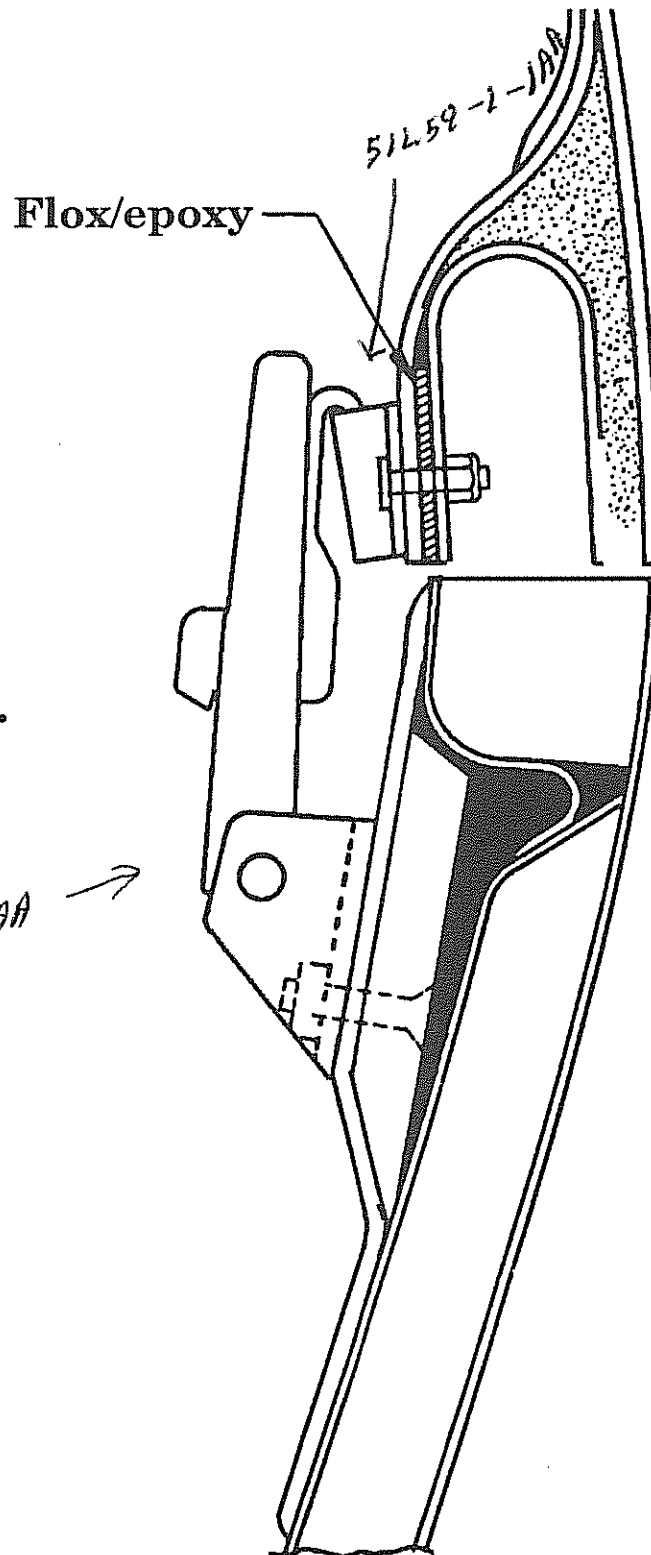

10. Drill and install the two machine screws that will pot in from the back side of the phenolic to secure the latch onto the face block. Use the MS24694-S8 screws and pot them into the phenolic in the usual manner (or you can install them as shown in figure 17-42, and pot in the all metal lock nut).

WARNING: When potting the machine screws into the phenolic block for the latches, do not remove any more of the phenolic than is absolutely required to lock the heads into the piece. Remember to file flats on the screw heads to prevent the screw from slipping. You may also use 1/2" phenolic if the installation of the latch requires additional shim distance.

NOTE: When setting the proper vertical alignment of the latches, check to verify that the internal latch adjustment is set to a mid range. The hook on the latch can be screwed up or down to fine tune the amount of pull produced when the latch is closed. This should be in the middle of its adjustment range to provide final adjusting room on both directions.

11. Now bond the phenolic onto the fslg using epoxy/flox. Clamp in position and allow to cure.
12. Wrap the machine screw studs with a piece of tape to keep the upcoming resin off of the threads. Now sand to smooth the edges of the phenolic, apply a flox fillet where necessary and add a 4 BID lay up over these four attach points. Contact at least 2" all around on the fslg sides. As always, be sure to clean and sand the bonding areas first. Make a good effort to keep the area of the phenolic (now with the 4 BID over it) smooth and flat so a good base is established for the latch to tighten up onto. Allow to cure then remove the tape and clean up the BID around the studs so that the latch will again seat solidly against the phenolic/BID base attachment.
13. Secure the latches with the two small (MS21042-832) all steel lock nuts. These are required since the available space is limited. Also mount the "strikes" using MS24694 machine screws. It is sometimes best (for clearance reasons) to insert them from the inside of the channel and attach the all steel lock nuts onto the outside. This will require a little hand operation of the counter sink. If there is room, you can of course run the screws in from the outbd side and place the nuts on the inside.



6. PROCEDURE: CANOPY COMPLETION (BOTH STYLES)

A. Canopy sealing surfaces preparation

There are almost as many 'preferred' methods of sealing the canopy as there are kits out there. One of the ones we've tried with excellent results is outlined here, and another is described for you to choose from, or give you ideas for a system of your own. They are both based on using the inflatable "D" seals we offer, and either one should require no more than 18 feet for a finished installation.

1. Where the longeron meets the roll over at the aft of the canopy, build up a smoothly rounded transition in the area where the seal will go from the horizontal longeron and go up the face of the roll over, using micro/flox. Sand it smooth. It should not have a radius that is too tight, or it will distort the seal. About 1-3/4" to 2" radius is good.
2. Smooth the aft portion of the canopy frame to match this transition area.
3. With the canopy frame back on the bench or floor, inverted, use the router or sand paper to remove a rounded channel from the side rail foam about 3/8" deep along the whole bottom of the rail, rounded, as shown in figure 17-43, below.

Routing channel for "D" seal

Figure 17-43

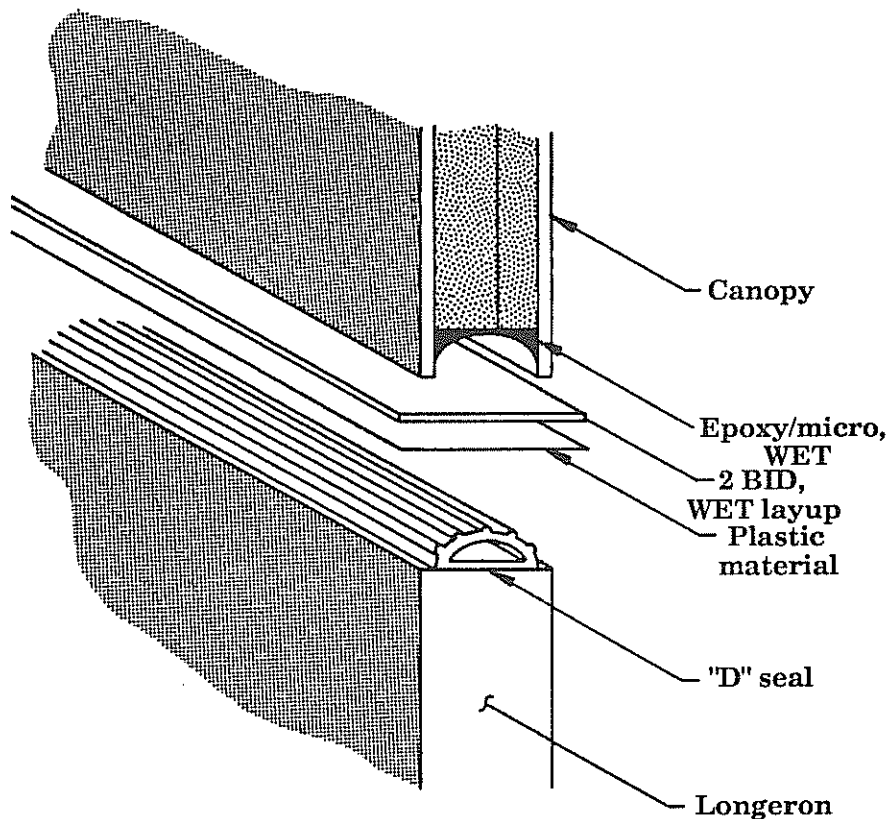

4. Clean the top of the longerons and the fuselage roll over surface where the seal strip is to be mounted.
5. Using some thin double-sided adhesive tape (available at most art/craft stores), tape the "D" seal into place on the longerons and fuselage roll over.
6. Using thin plastic (like the supermarket grocery bags), cover the seal completely from end to end, taping the plastic lightly into place so that the plastic can still move enough to closely conform to the shape of the seal in step 9, below.

NOTE: These next few steps can best be performed with a couple of extra hands. Make sure everything is covered that might be hit by dripping epoxy:

7. Referring to figure 17-44, lay up a 2 BID strip long enough to go over the "D" seal for the length of the longerons. Don't force out the excess resin, leave it a little 'juicy'. Lay this over the plastic, leaving it just lay flat. It is best to do both longerons at one time.



Sealing side rail channel

Figure 17-44

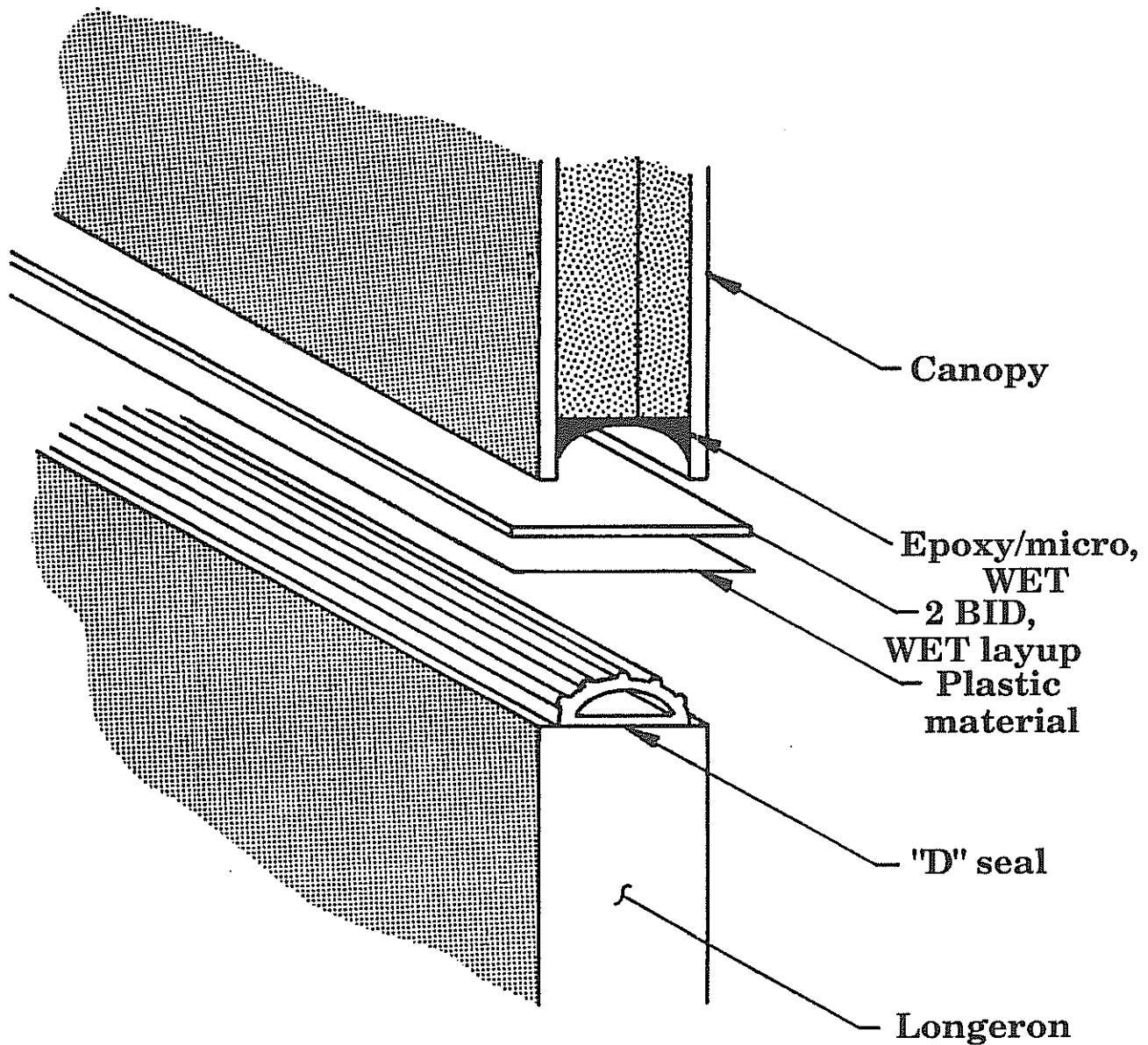

8. With the canopy upside down, use a mix of epoxy and micro to fill any voids in the channels you sanded out. Now pour into the channel an epoxy/micro mix about 1/4" deep, then spread it inside the channel so that it is evenly coating the channel.

9. While the 2 BID layup and the micro mix are both wet, turn the canopy right side up and carefully place it in position on the fuselage. Weight the canopy frame down so that it forces out all of the excess micro, and you should now have a channel that precisely conforms to your seal, even without inflation. When you are done installing your latches, they should put just enough additional pressure on the seals to make them work perfectly.
10. After the curing process is complete, take off the canopy, invert it on the bench or the floor, and trim off the excess BID, sanding the bottom of the rail smooth.

NOTE: You can use this same process later to do the seal at the roll over.



B. Alternative sealing methods

There are as many alternative mounting methods as there are kits out there. One alternative is to mount the seal into the canopy, leaving the top of the longeron flat to act as the sealing surface.

Some drawings and thoughts to help you, if you decide to take this approach, are included herewith:

Possible methods of sealing canopy
Figure 17-45

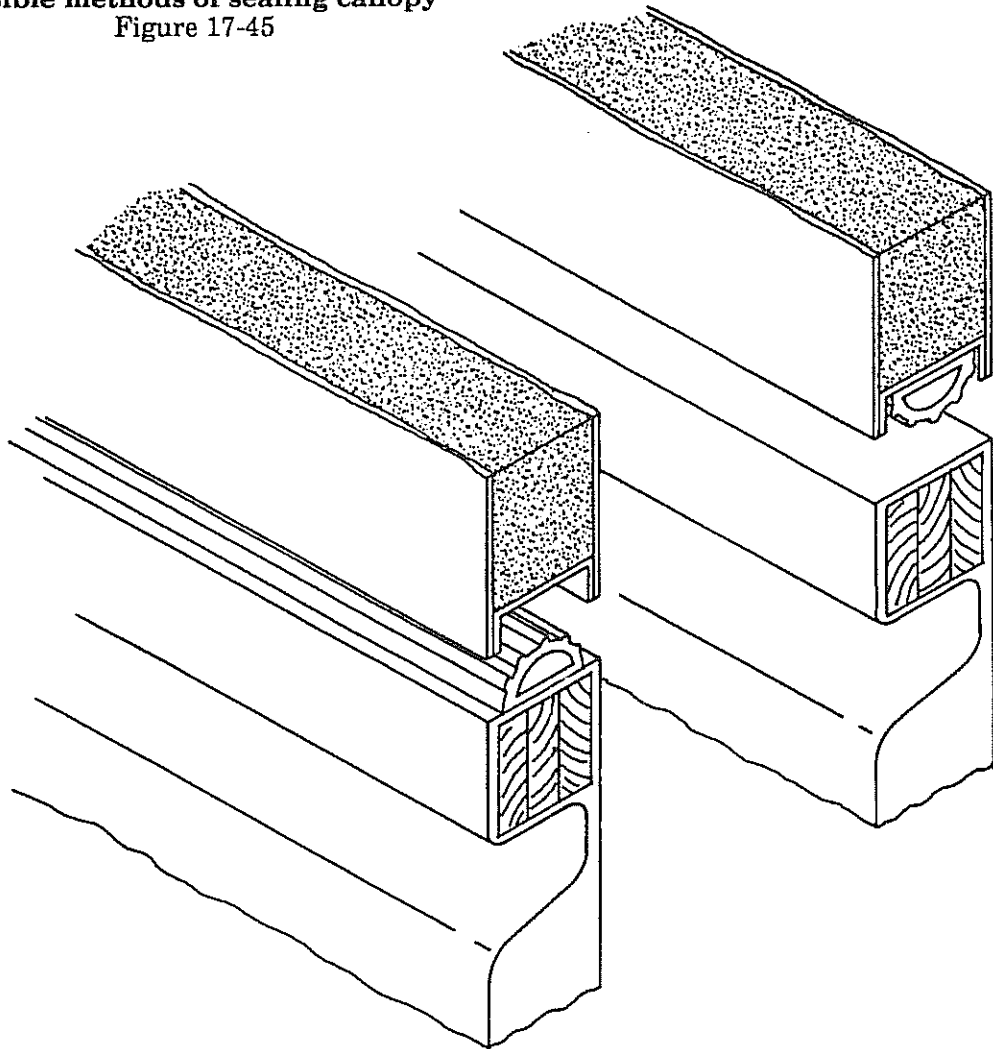

In stead of mounting the seal on the longeron as shown the left of figure 17-45, route a channel in the canopy wide enough for the channel, and just deep enough so that when in place, the seal will be compressed about 1/8", as shown at right.

Alternative sealing methods to consider

Figure 17-46

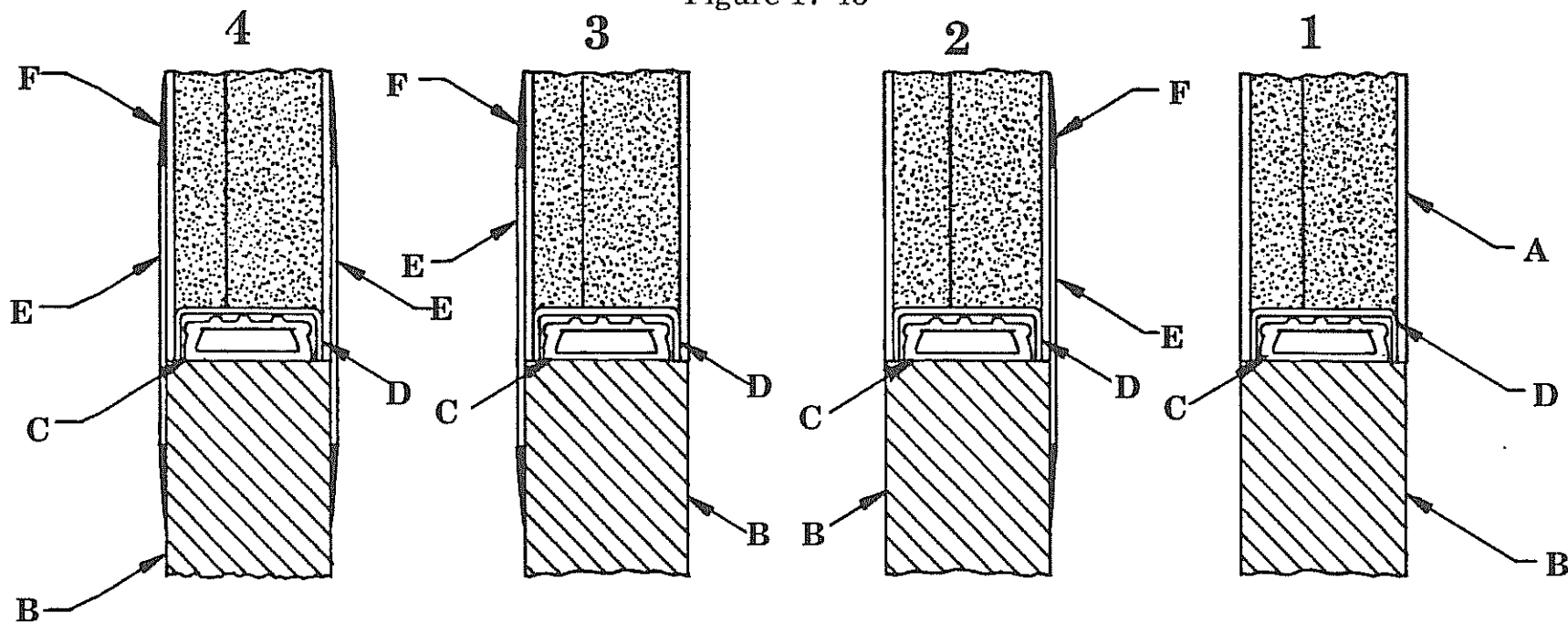

- "A" = Canpoy frame
- "B" = Longeron
- "C" = "D" strip
- "D" = 1 BID lay up
- "E" = 2 BID, bonded to frame, released from longeron
- "F" = Micro fairing



Figure 17-46 shows several alternative methods to consider, each having its own merits. In any of these methods the "D" strip could be mounted either in the canopy or on the longeron.

Method 1:

A channel is routed into the canopy frame, a 1 BID layup is inserted to give the "D" strip a good surface to be attached. Relatively simple, it gets the "D" strip out of the way, so people entering/leaving will not submit it to wear and tear.

Method 2:

Same as "1" above, but a 2 BID layup is bonded onto the outside of the canopy frame, extending down past the longeron. Keeps lateral movement to a minimum, and decreases noise significantly, but requires some fairing in to keep your lines nice.

Method 3:

A variation of "2" above, it puts the 2 BID on the inside. Makes the outside lines nice, but should be faired in on the inside.

Method 4:

A combination of all three methods above, it gives excellent noise rejection, virtually eliminating any air noise around the seal, requires a lot more work to fair in both inside and out.

These are just some of the possibilities. If you come up with a good one, document it and let us know, we'll try to put it in the newsletter for others to enjoy.



C. **Alternative latching method for fwd hinge canopy - draw bolt style**
If you consider using this method, you may want to install bushings in the roll overs, and then you can use a tapered pin to draw the hatch down as the pin goes into the fuselage roll over, giving you the 'crush' you need on the "D" seal to make it work. Be sure you set it up so that it is "over-center" locked, and cannot be accidentally released in flight.

This should only be used with the fwd hinge system, unless a similar latch is used at the front of the canopy as well as the rear, shown here.

ALTERNATIVE LATCHING METHOD
For 320 with Fwd Hinge Canopy
Figure 17-47

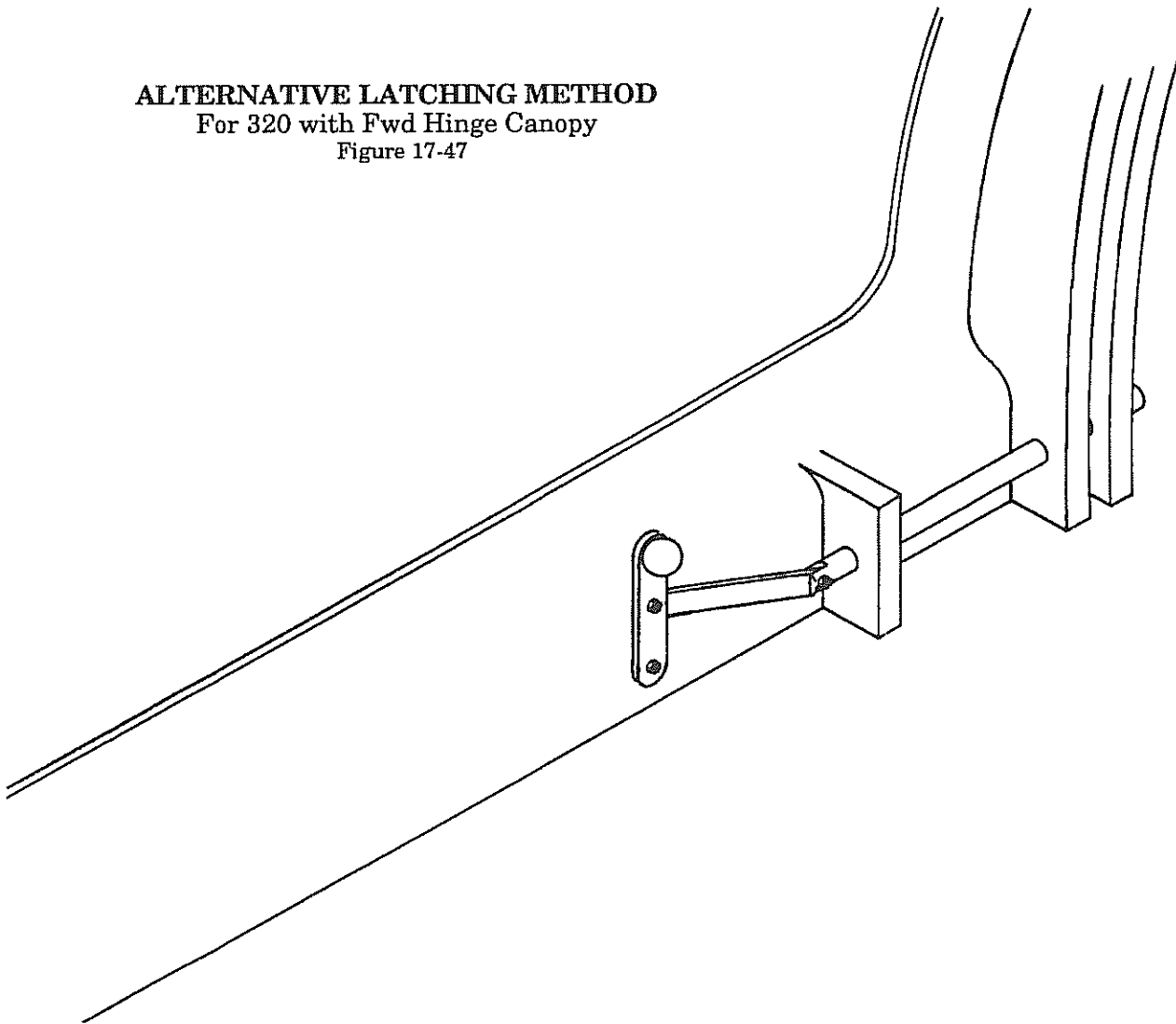

D. Alternative latching method for fwd hinge canopy - Lever style

Referring to figure 17-48, the lever style latching mechanism is ideal for the forward hinge canopy system (but not recommended for the standard parallel style canopy opening system, since four would be needed). It is more expensive than the other systems, but it is a fine touch to give your plane, and the ease of operation is unmatched in any other latches we have found. This latch should be installed *AFTER* you have installed the canopy seal, so that proper spacing and pull will be achieved.

Lever style latch mechanism

Figure 17-48

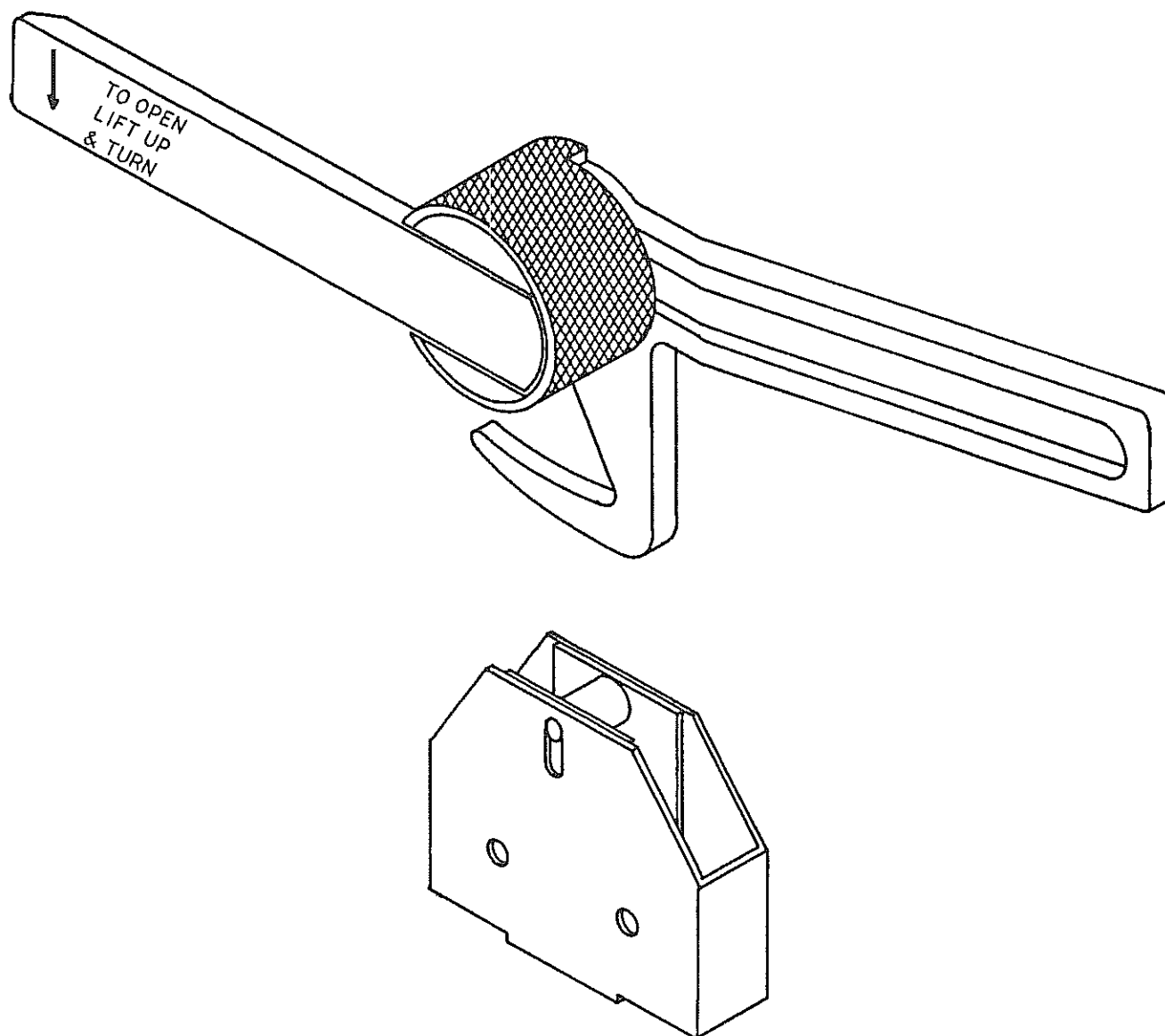

1. Select a location as far aft on the canopy frame as is comfortable to reach, and will not interfere with normal pilot or passenger movement while seated.
2. Mark a location per figure 17-49 at the positions you have chosen.

POSITIONING LEVER LATCH

Figure 17-49

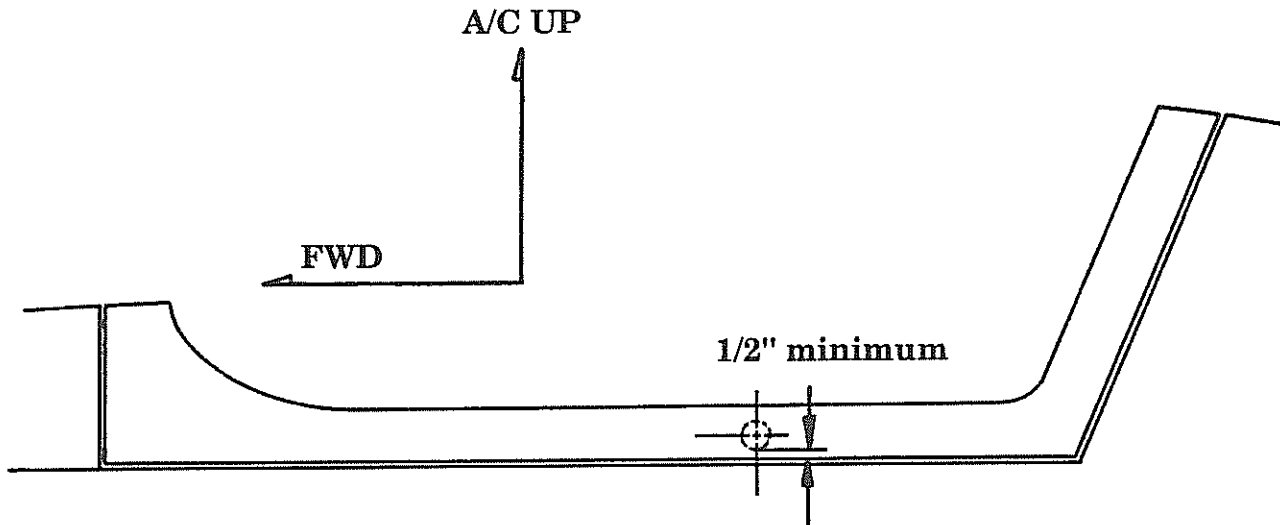

3. Starting with a small drill bit and working your way up, drill or grind a hole completely through the frame that is 1-9/16" in diameter, which is slightly smaller than the bushing (refer to figure 17-50). The more snug the fit of the knurled bushing, the easier the next steps will be. You can remove the phillips head screw and the handles will come off, leaving you with just the aluminum barrel you can use to establish the fit. The goal here is to get the inner and outer skin to hold the bushing in exactly the right position so that clamping later will not be necessary. Sand or file the hole out until the bushing can be inserted through, but is held firmly in place by, the inner and outer skin of the canopy.

NOTE: While it is ideal if the canopy frame matches the bushing thickness, it is not really necessary. If the frame is narrower than the bushing, it can be built up later in just the bushing area. If it is wider, then some material will have to be removed, smoothed down and then covered with 4 BID for reinforcement.

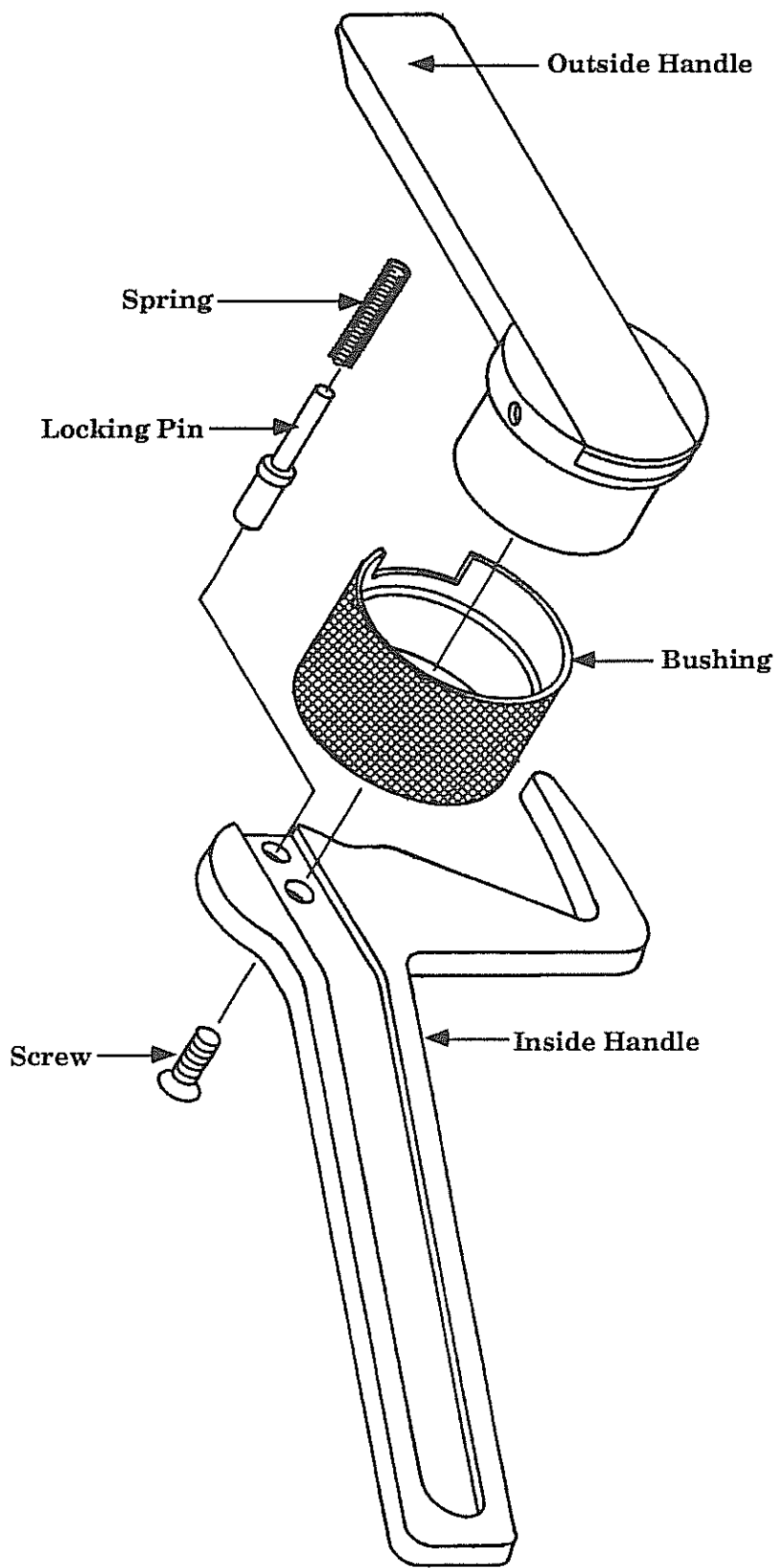

LEVER HANDLE ASSEMBLY
Exploded view
Figure 17-50

- Using a Dremel or similar tool, route out the finger recess area on the outside of the canopy frame as shown in figure 17-51. This slot should be parallel to the canopy frame line.

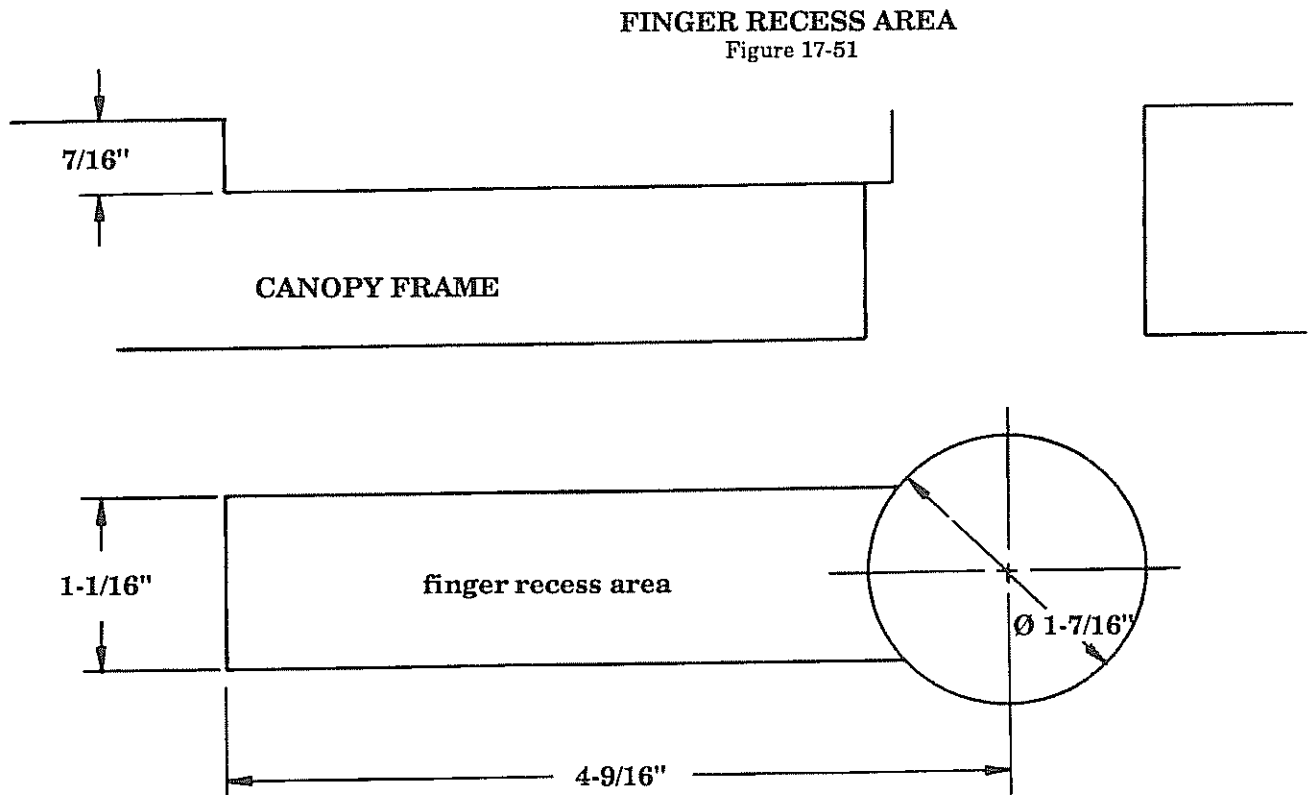

- Per figure 17-52, prepare 3 tongue depressors about the handle as shown. Shape one piece to go under the handle and fit snugly to the bushing. Secure it there to the handle with a small dot of hot glue or equiv. Do not get any adhesive on the bushing!
- Shape the other two tongue depressors, and hot or instant glue them along the sides of the first stick and handle as shown in figure 17-52.
- Shape a small piece of wood to the same profile as the tongue depressors, and glue it between them at the end of the handle as shown. The outside shape of this will be the indent for your handle, and provide the necessary finger recess and handle clearance. Sand the end radius smooth between the two sticks and the small piece of wood, and lightly sand a radius onto the tongue depressors running the length of the handle.

8. Apply either wax or plastic release tape to the exterior of the wooden block and tongue depressors.



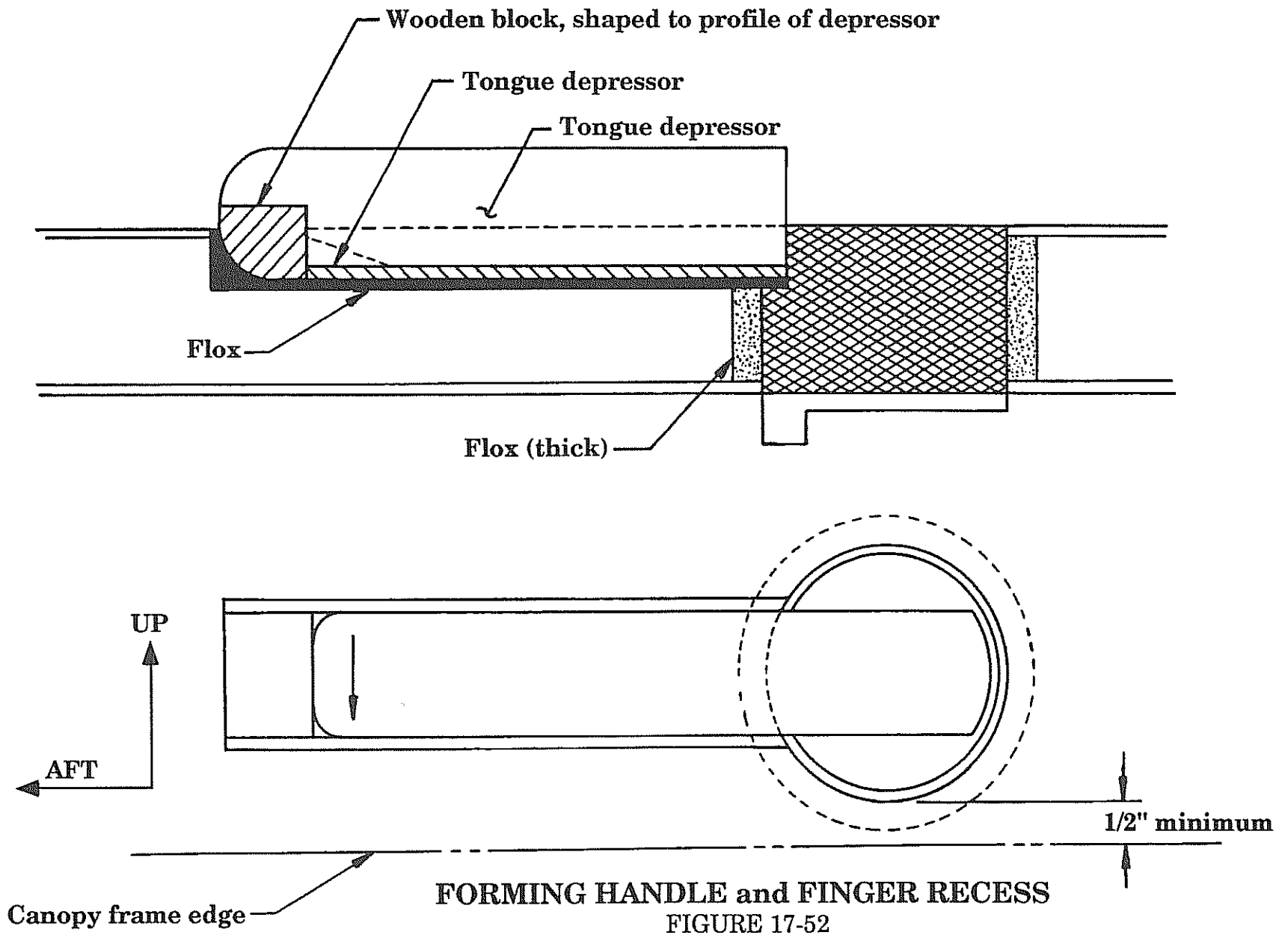

9. Remove 1/8" to 3/16" of the foam from inside the canopy frame around the area the bushing will be placed using a rotary router or equiv., being careful not to remove any of the glass that will be holding the bushing in position.
10. Mix up a sufficient batch of epoxy, then brush a light coat of epoxy into the handle recess area to make sure you will get a good bond. **DO NOT GET ANY EPOXY IN THE AREA NEAR THE BUSHING LOCATION. LEAVE AT LEAST 1/2" BETWEEN THE EPOXY AND THE HOLE FOR THE BUSHING.** Then add micro and flox to the remaining epoxy and put it into the recess, so that it is covered entirely with at least 1/8" of micro/flox, *except for that last 1/2" near the bushing, which should be left free of micro/flox.* **WE ARE ONLY DOING THE HANDLE AREA AT THIS TIME.**
11. Slide the bushing, with the outer handle and it's protecting tongue depressors in place (the inner handle removed, of course), into position and press it in until the bushing and the handle are flush with the exterior surface of the canopy frame, as shown in figure 17-52. Wipe off excess micro/flox that squeezes out.
12. Before the micro/flox can completely harden, remove the bushing by pushing it through to the inside of the frame, being careful not to disturb the position of the handle. Using acetone, clean off any micro/flox that might have gotten onto the bushing.
13. After the micro/flox has cured, remove the handle from the tongue depressors, leaving them in place, if possible. If they come out with the handle, separate the handle from them and reinsert them into the frame. The sticks will have to be in place for the next steps to properly align the lever assembly to the position of the handle recess.
14. Carefully tape the inboard portion of the bushing, where there is no knurling, with release tape.
15. Paint a thin coat of epoxy inside the frame where the bushing will mount. Add some flox to the remaining epoxy, mix and paint the knurled area of the bushing with it to completely fill in the knurling. Add more flox to make a stiff mix, and fill the area in the frame shown in figure 17-52.
16. Carefully insert the bushing from the inside to the outside of the frame, lining it up by eye with the handle location as it emerges. Wipe off any flox that is on it when it emerges with acetone.



17. Insert the outer handle and use it to line up the bushing, so that the handle fully seats into the tongue depressors, flush with the frame side, and the bushing is also flush with the frame exterior side. When the flox is set sufficiently to hold the bushing in place, remove the handle and clean it, and remove the tongue depressors. You can now add a little more epoxy/micro to fill in that 1/2" area that you carefully kept clear earlier.

NOTE: be sure you have removed any micro or flox from the handle and the inside of the bushing while it is still easy to do so. You could sand off the epoxy/micro/flox residue later, but that might scratch the anodizing, and you paid too much for these beauties to scratch them up now.

18. After the flox has cured, sand a nice radius to the edges of the finger recess.
19. Install your canopy onto the fslg and assemble the complete latch handle into the bushing.
20. Next we need to mount the latch striker such that the center of the roller pin is directly below the center of the phillips head screw. Since your canopy seal is new and fresh and thick (and hopefully already installed), you can easily establish the best position for the roller assembly by loosening the stop nut until the inner roller yoke can be pulled up to the edge of the roller housing. Sitting inside your plane with the cockpit closed, put the latch handle in the closed position and hang the roller assembly from it as shown in figure 17-53. Gravity and the precision roller will automatically level it for you.
20. Looking down into the assembly, slide the assembly inbd or outbd until the latch arm is centered on the roller. You can now measure the gap, if any, that must be filled between the roller assembly and the longeron.

NOTE: The roller pin extends out slightly from the roller housing on both sides. THIS IS INTENTIONAL, should not be tampered with to make it flush, and must be taken into account when mounting the assembly. A small groove should be ground behind the roller assembly so that it can be adjusted in the future without distorting anything.

NOTE also that there will be 4 BID placed behind the roller assembly, so leave a little space in your calculations for this.



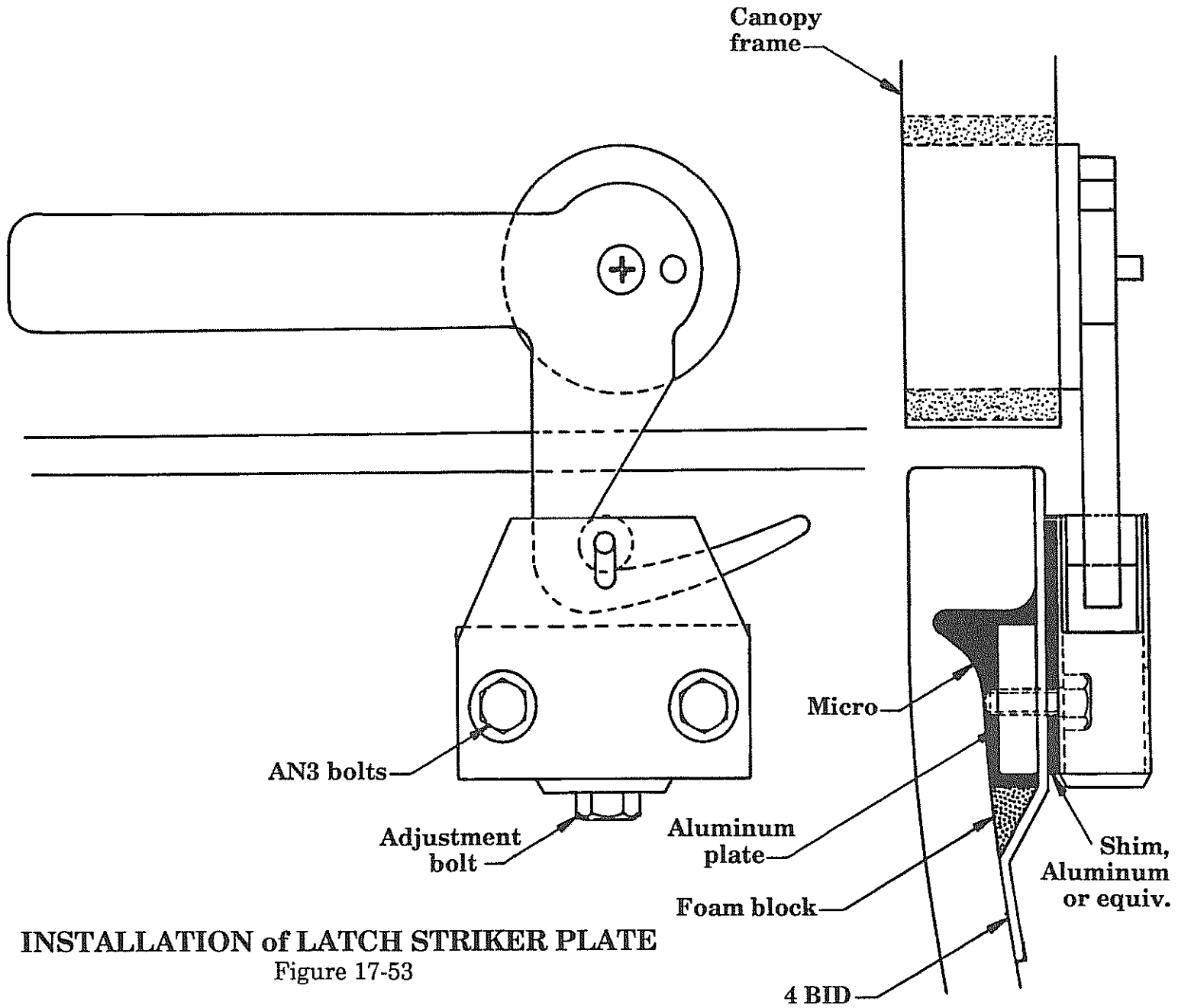

INSTALLATION of LATCH STRIKER PLATE

Figure 17-53



21. Referring to figure 17-53 and 17-54, carve a foam block to fill the gap between the latch striker plate, longeron and inner fslg skin.
22. Using epoxy/micro, bond the block into place.
23. Reposition the pin assembly and mark the outline of the assembly onto the foam.
24. Cut two pieces (one for each side) of 1/4" x 1" x 2" aluminum plate.
25. Cut a slot in the foam for the plate so that it is positioned as shown in figure 17-48e, and remember to bed it deep enough to allow for the 4 BID lay up between it and the roller assembly.
26. Using epoxy/flox, bond the aluminum plate into position, being sure to rough up the surfaces with 40 grit and clean it with MC just prior to bonding it in place.
27. Lay 4 BID over the foam and aluminum as shown in figures 17-53 and 17-54 and let cure.
28. Reposition the roller assembly and mark for the 2 mounting screws.
29. Remove the roller assembly, drill and tap the aluminum plate for the two 10-32 screws (be careful with the drill, you just need to go through the aluminum plate).
30. Install the roller assembly using two AN3-6A bolts (be sure you have a groove behind the assembly for the roller pin to travel freely in).
31. You can now close the canopy, latch it and, using the stop nut adjustment on the bottom of the roller assembly, draw the canopy down for a nice snug closure.



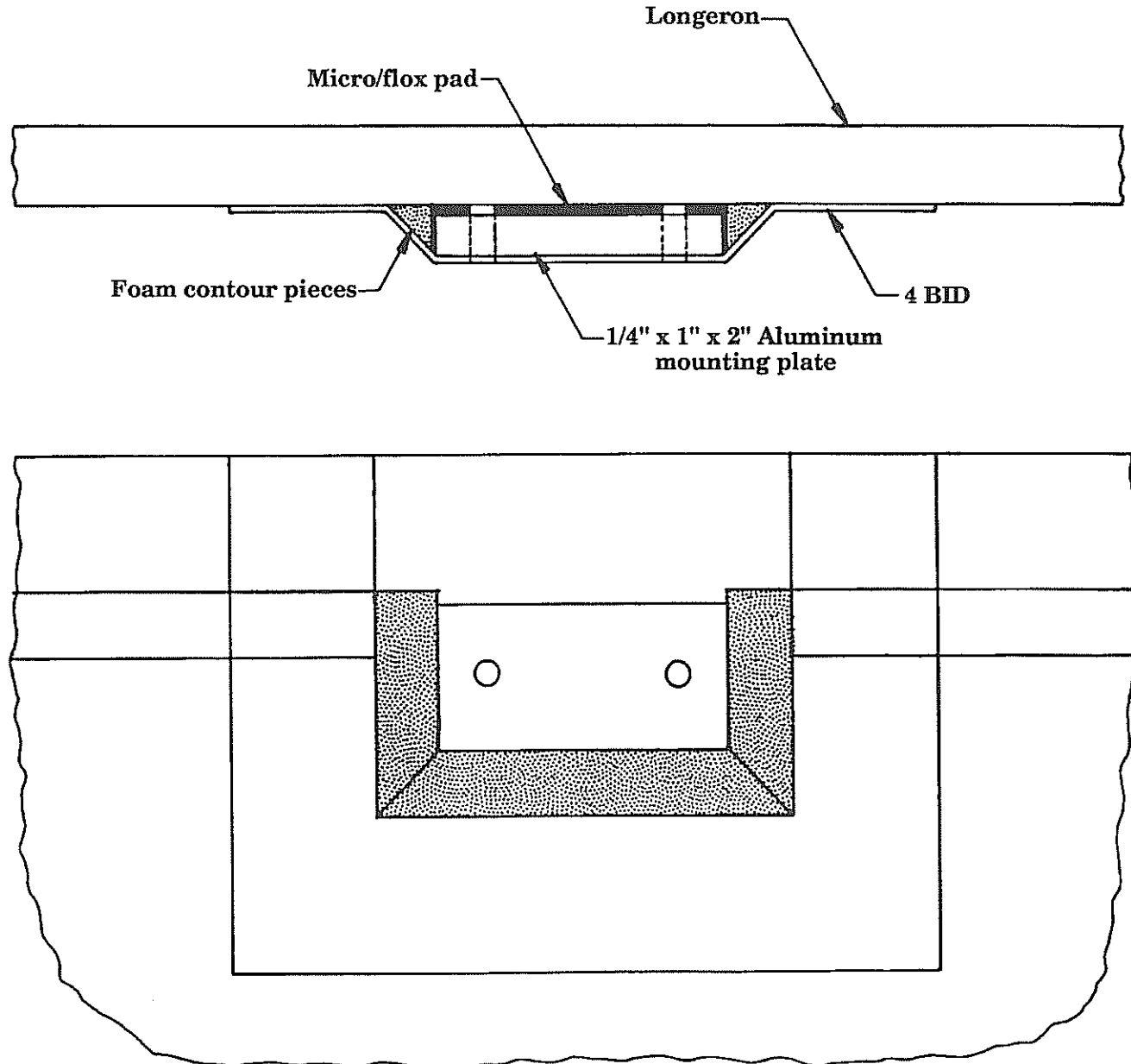

Bonding striker plate into longeron

Figure 17-54



E. Canopy locks - External

For the standard opening canopy, two standard hardware store variety tumbler locks can be easily installed to secure the canopy down from the exterior. One is required per side (on the fwd hinge canopy, you may want to consider just mounting one at the top aft center, if you can conveniently reach it). See figure 17-55.

CANOPY LOCKS

Figure 17-55

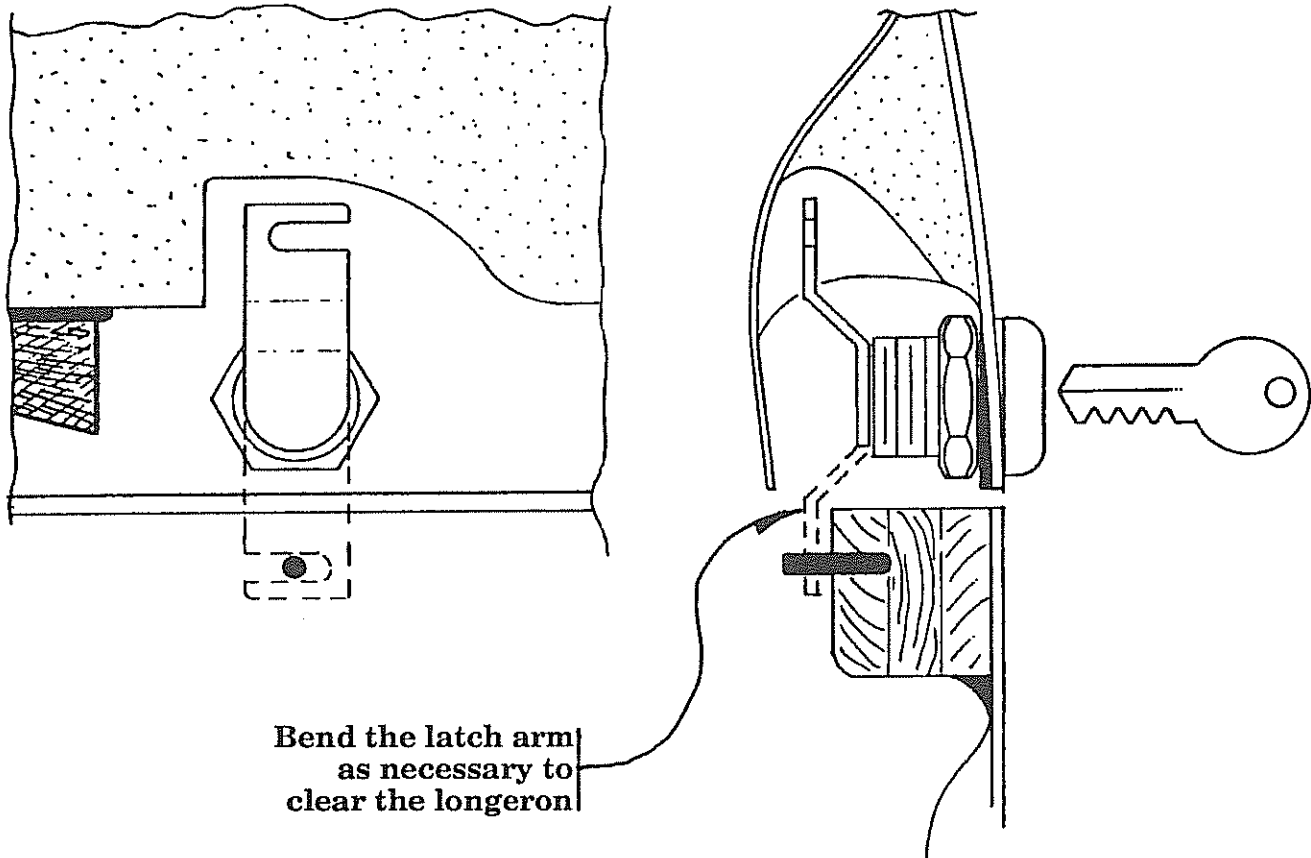

1. It is important to calculate the rotation of the latching arm on the lock tumbler and verify that it does have room to swing.
2. Drill the hole into the outboard canopy frame side and install the tumbler.

3. Drill the hole into the longeron to install an AN3 bolt used as a stud pin upon which the tumbler arm will swing around and catch upon. Pot this into the longeron from the inside using epoxy/flox or structural adhesive.
4. Adjust the arm only when you have the final "P" strip or equiv. on for the canopy seal. The lock should be set to require just a little downward pressure in order to set the arm around the pin.



F. Aft window installation

1. These aft 1/4 windows will be installed in a similar manner as used for the canopy, refer back to canopy glass installation, page 17-61.
2. It is recommended that one rear window be left out until the very last. This will provide easier reach through access into the baggage area, etc.
3. Use the same 2 BID ply schedule to secondarily attach the aft 1/4 windows on the inside.



G. Final canopy fairing - in process

It seems builders often get anxious about achieving a good canopy installation. It is really quite simple.

1. Fairing the fslg/canopy seam: With the canopy completely built, reach through the aft 1/4 window holes and secure the four latches. The "P" strip or equiv. should be in place. If you want to save this sealer material for final use, you had better cover it with tape. It is best to have some throw away material that can be used here.
2. Mix up a batch of dry micro and after cleaning and sanding the mating surfaces, spread a thin layer along the joint lines of canopy to fslg. Don't worry about keeping it away from the actual seams, just spread it right over them. Then follow back by running a knife blade or mixing stick edge, all along the seam line. This will redefine the part line. Allow to cure and sand with a flat board.
3. Fairing the canopy frame/windshield seam: While the canopy is on the fslg, peel the tape back and retape it about 1/8" back on the plexiglass.
4. Go around with a small piece of 50-80 grit sandpaper (folded over) and sand the resultant edge and freshly exposed plexiglass. Follow up with micro that is not too dry so that it will go on smoother but not drip. Apply just a little all around the perimeter and allow to cure. Sand that down later which will start a smooth progressive taper from the outside of the canopy frame down to the level of the glass.

Later, you'll do this again prior to primer and once again prior to painting. The result is a smooth transition that is easy to do.

NOTE: You'll also want to line up the canopy line with the aft 1/4 window line.



H. Canopy closure guides

These should not be needed, but if you feel that they are necessary for your particular canopy system, here is a simple method of making the canopy come down in the precise position on the longerons that you desire. Make them from aluminum, and install them much the same as the latch strikers. Note the bevelled edge on the upper plate to guide it onto the lower plate. See figure 17-56.



Canopy Closure Guide
Figure 17-56

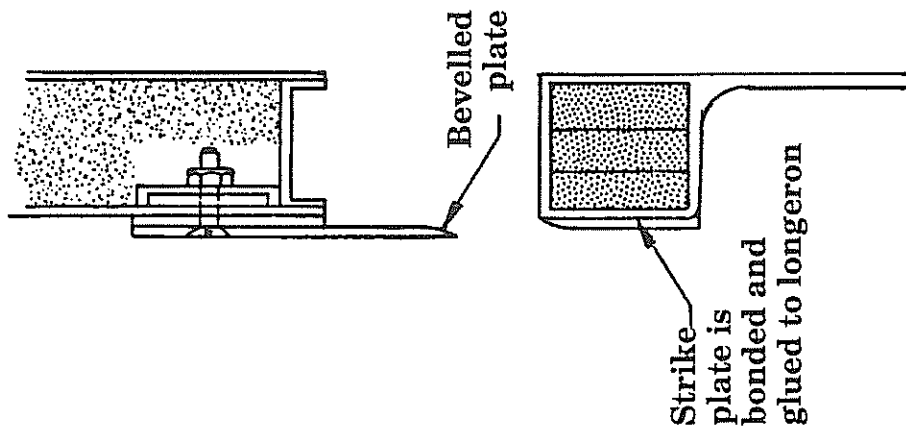
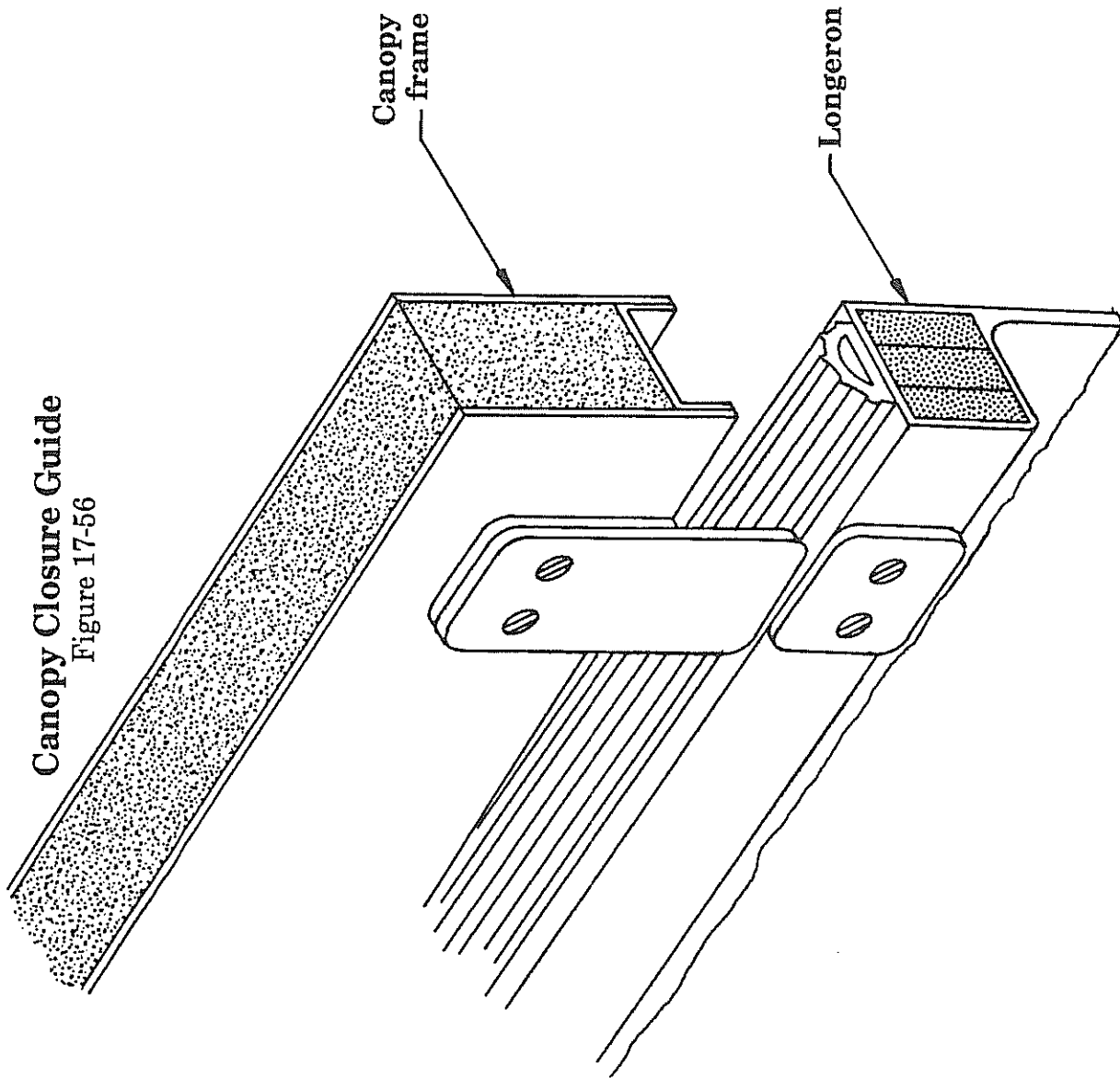

7. PLEXIGLASS HINTS FOR PERFECT CANOPIES

From: The Airplane Factory, Inc.
7111 Brandyvista Ave.
Dayton, Ohio 45424

A. Cutting:

An abrasive disc powered by a high speed drill, a Dremel tool, or a hand held circular saw is recommended. We have found that abrasive cut-off wheels of aluminum oxide or silicon carbide provide excellent cutting results. A six inch disc is available at most hardware stores for around \$3.50. A small grinding disc or Dremel saw disc will also give good results. Reciprocating saws like saber saws are **NOT RECOMMENDED** and will probably break your canopy. A tool that progresses slow and hot to grind through the canopy is best. Tape a poly plastic cover on the canopy and mark your outline with masking tape.

Never cut a cold canopy. Allow the canopy to warm to 70° or more for at least an hour. Don't allow the canopy to vibrate or chatter during the cutting or it may chip and crack. Support your canopy on a flat surface so it will not twist or spread during the trimming. Duct tape is handy to hold things in place. Remember: cut slowly, don't push the cutter. Let the tool do the work. Be sure to use eye protection. Plexiglass chips can be a problem in your eyes since they are clear and difficult to see.



17-94

Chapter 17

REV.

0 / 11-1-91

CANOPIE SYSTEMS



B. Drilling:

The drill should be ground off to a zero rake angle to prevent digging in, chipping and cracking the Plexiglass. A standard drill bit, ground with no cutting edge pitch, is a safe method of making holes. Be sure to make the holes oversize to allow for motion caused by thermal expansion and contraction. The drill bit should not be allowed to chatter or it will chip and break the Plexiglass. Don't push the drill. Let it cut at it's own rate.



17-95

Chapter 17

REV.

0 / 11-1-91

CANOPY SYSTEMS



C. Cleaning:

A damp soft cloth or an air blast will clean the saw dust away. The damp cloth will also dissipate static electricity. To clean dirty plexiglass use plenty of water and a non abrasive soap or detergent. Dry with a clean chamois or soft cotton. NEVER use acetone, benzene, carbon tetrachloride, lighter fluid, lacquer thinners, leaded gasoline, window sprays or scouring compounds. Grease or oil may be removed with kerosene, white gasoline, naphtha or isopropyl alcohol. Small scratches can be buffed out with "Mirror Glaze" HGH-17 and a lot of rubbing. Hard automobile paste wax should be applied as a protective coating and buffed with a soft cotton flannel cloth. Do not use cheesecloth, muslin or shop cloths, they scratch. For deep scratch removal, procure a hand polishing kit from a plexiglass dealer or your canopy supplier.

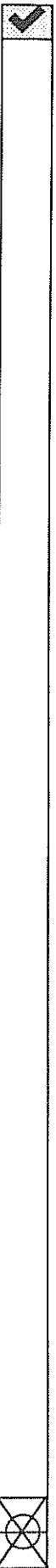

CHAPTER 18:

GENERAL & FLAP ELECTRICAL SYSTEMS

REVISIONS

From time to time, revisions to this assembly manual may be deemed necessary. When such revisions are made, you should immediately replace all outdated pages with the revised pages. Discard the out dated pages. Note that on the lower right corner of each page is a "revision date". Initial printings will have the number "0" printed and the printing date. All subsequent revisions will have the revision number followed by the date of that revision. When such revisions are made, a "table of revisions" page will also be issued. This page (or pages) should be inserted in front of the opening page (this page) of each affected chapter. A new "table of revisions" page will accompany any revision made to a chapter.

Arrows

Most drawings will have arrows to show which direction the parts are facing, unless the drawing itself makes that very obvious. "A/C UP" refers to the direction that would be up if the part were installed in a plane sitting in the upright position. In most cases the part shown will be oriented in the same position as the part itself will be placed during that particular assembly step. However, time goes on and changes are made, so careful attention should be paid to the orientation arrows. That old cartoon of the guy agonizing over the plans for his canoe, built one end up, one end down, should not happen in real life. Especially to you.

CONTENTS

1. INTRODUCTION
2. DRAWING LIST
3. EQUIPMENT REQUIRED - SPECIAL PARTS, TOOLS & SUPPLIES
 - A. PARTS
 - B. TOOLS
 - C. MATERIALS & SUPPLIES
4. PROCEDURE:
 - A. GENERAL INSTRUMENT PANEL AND AIRFRAME WIRING
 - B. BATTERY & MASTER RELAY INSTALLATION
 - C. POWER BUSES FOR INSTRUMENTATION, ETC.
 - D. FLAP WIRING
 - E. SETTING FLAP LIMIT STOPS



1. INTRODUCTION

There are three basic areas concerning the electrical systems:

- 1.) General Panel Wiring;
- 2.) Flap Wiring;
- 3.) Landing Gear Wiring.

The landing gear wiring has already been discussed in chapter 14. This chapter will address the two remaining areas.



2. DRAWING LIST

Drawing	Page	Title
18-1	18-7	Basic wiring schematic
18-2	18-8	Battery box aft installation
18-3	18-9	Battery box fwd installation
18-4	18-12	Buss bar positioning
18-5	18-14	Flap motor wiring schematic
18-6	18-16	Flap relays
18-7	18-17	Flap reed switch
18-8	18-18	Flap wiring layout
18-9	18-19	Flap motor enclosure



LANCAIR[®] 320FB

18-3 .

Chapter 18

REV.

0 / 11-1-91

General & Flap Electrical Systems

3. EQUIPMENT REQUIRED - SPECIAL PARTS, TOOLS & SUPPLIES

A. Parts

- Mag switches (2)
- BUSS terminals A/R
- Starter switch, momentary ON
- Master relay (optional)
- Master switch (optional)
- Alternator switch
- Starter relay
- Wire as required
- Battery
- Wire ties as required
- Battery cables, connectors as required
- Flap motor (12V linear actuator)
- SPDT relay, flaps (2)
- Flap switch, DPDT
- .187" spade connectors as needed



B. Tools

- Book, "Firewall Forward" by Tony Bingalis
- tape measure
- Pencil
- Wrench (for battery terminals)
- Lug crimping tool (for wire connectors)



C. Materials & supplies

- 1/4" prepreg for construction of battery box
- epoxy
- BID cloth
- sandpaper
- Duct tape or release tape
- MC or acetone for cleaning
- structural adhesive
- plastic tape (release tape)
- instant or hot glue



4. PROCEDURE:

A. General instrument panel and airframe wiring

1. There are a great variety of approaches to the basic wiring schematic for the aircraft. We will depict one of the simplest below. It is highly recommended that you purchase the book "Firewall Forward" by Tony Bingalis. Tony has beautifully addressed basic wiring and covers all standard applications very well. The wiring diagram in figure 18-1 represents a simple and general approach to a non-aluminum airframe with some of the particulars added that would specifically address the Lancair's basic requirements, i.e.: battery mounting in the aft fuselage section, landing gear power pack, etc.

BASIC WIRING SCHEMATIC

Figure 18-1

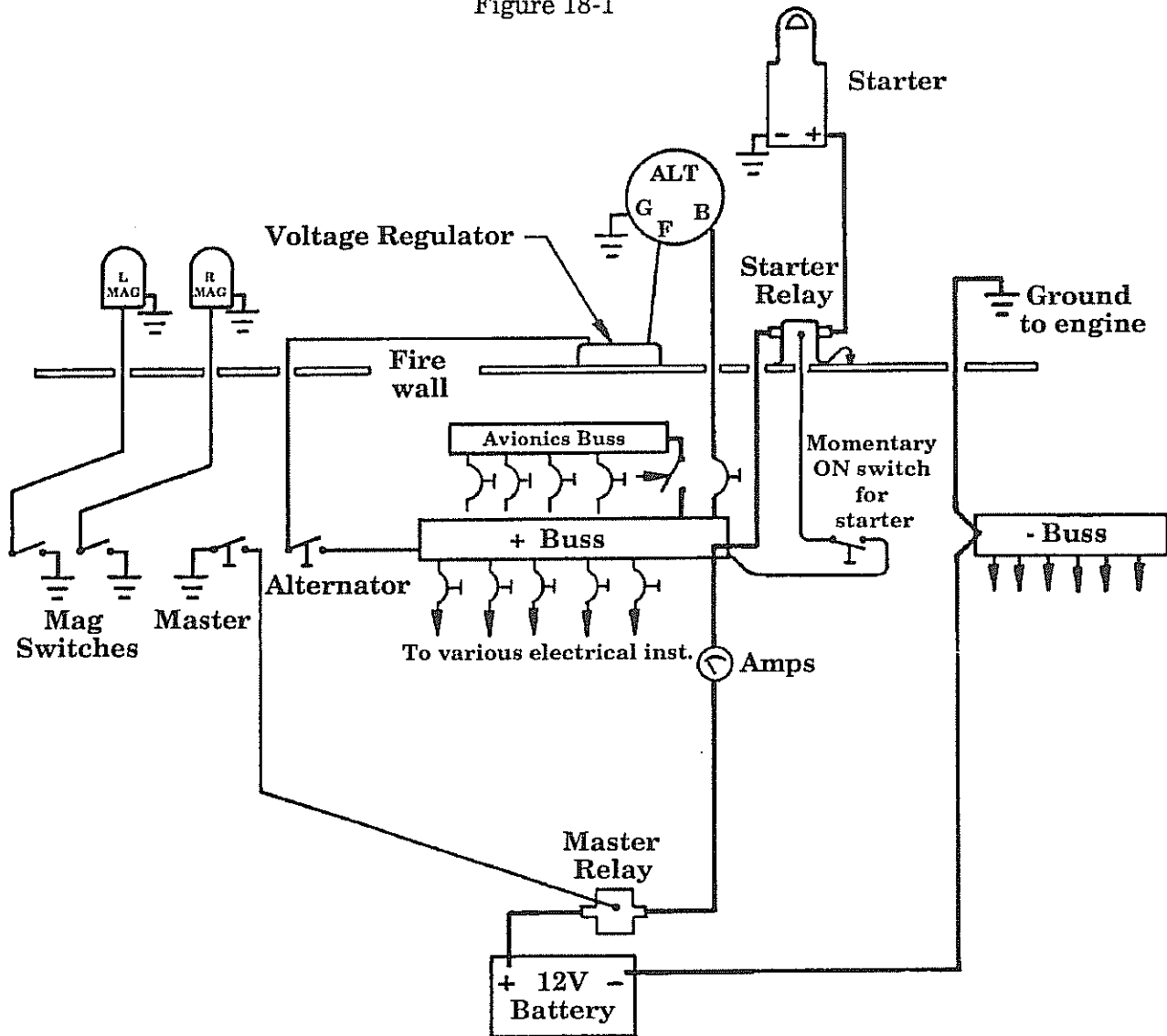

B. Battery & master relay installation

1. The battery on the Lancair should be used as a final "trim" weight when establishing the proper empty weight CG. See chapter 20 titled "Weight and Balance".

Generally, the battery will install just aft of the baggage bulkhead, on the right side of the tail cone when you are set up with a constant speed propeller. If a fixed pitch, wood propeller is used, the battery may be installed directly behind the passenger's seat. It is also conceivable that this engine prop combination could require a light battery to be installed on the firewall. That is why it is best to complete the basic airframe installations prior to fixing the battery location. Otherwise, you would have to use "ballast weights" to bring the airframe into proper empty CG limits. And that is often useless weight.

2. Figure 18-2 shows a simple means of installing the battery box in the aft position (behind the baggage bulkhead). This is also the most convenient since it allows for the shortest possible line connections to the hydraulic power pack.

BATTERY BOX AFT INSTALLATION BEHIND BAGGAGE BULKHEAD

Figure 18-2

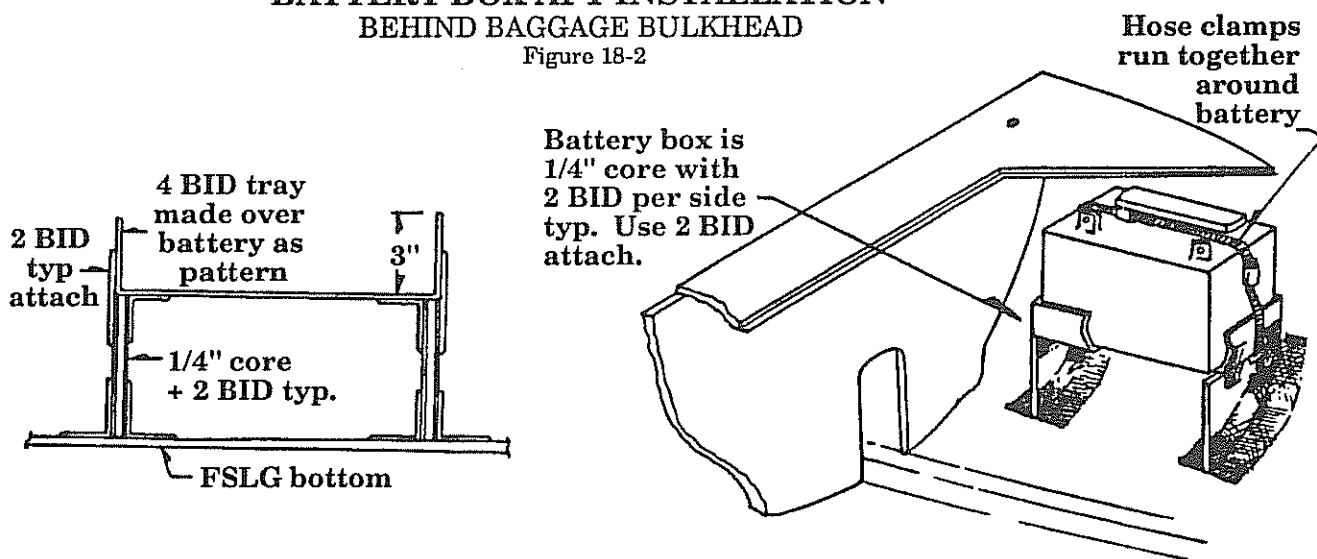

3. Figure 18-3 shows a typical installation of the battery behind the seat. In this installation note that the master relay is also located nearby.

BATTERY BOX FWD INSTALLATION BEHIND SEAT

Figure 18-3

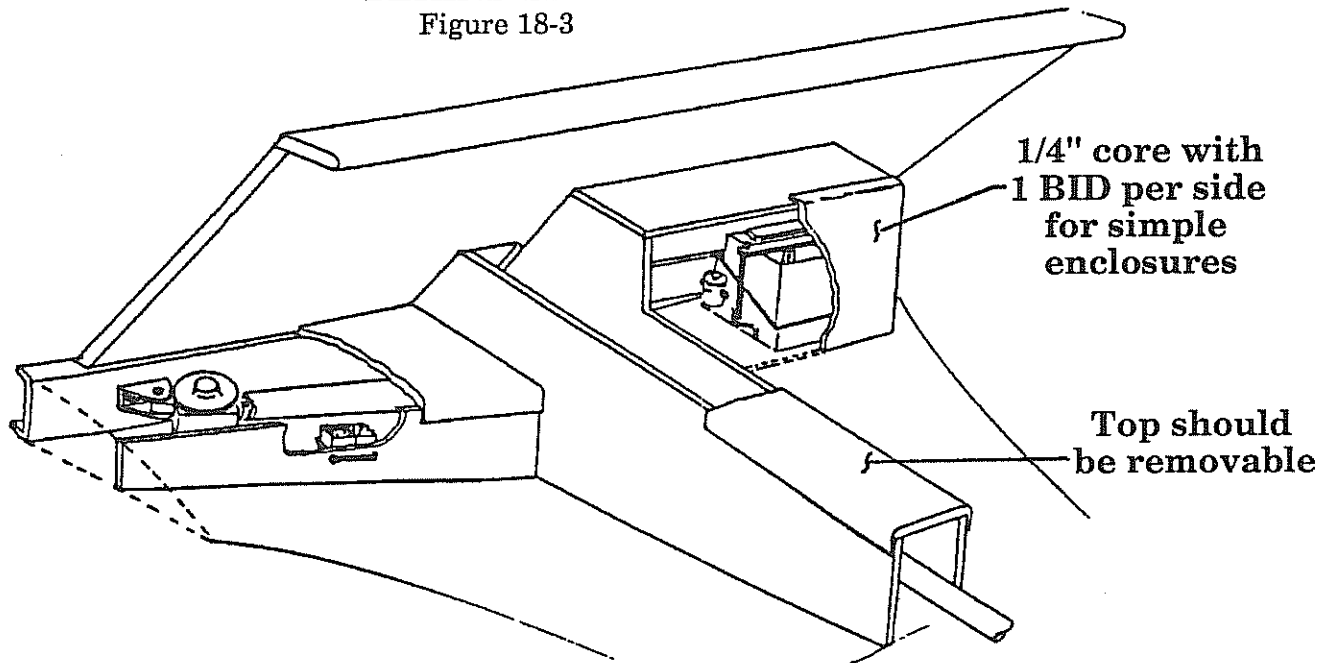

4. The master relay is required for safety reasons. This master relay must be a continuous duty relay (they are not supplied as standard with the kits). The master relay should be located near the battery so that when power is cut (by opening the "master" switch on the instrument panel, no live wires will remain throughout the airframe. (Actually though, you will likely have one or two small "live" wires to provide continuous power to items like clocks, fuel totalizers, etc.)
5. Battery cables should be #4 wire and should run up the center of the fuselage, under the spars, through the tubing inserted into the sub-floors and on through the firewall into the engine compartment.

In general, all wiring can run through the center console area but you should keep the antenna coax cables away from other electrical wires. These antenna cables can be run along the sides of the fuselage, over the spars. Running them along the outboard sides of the fuselage is generally acceptable between the upholstery panels and the fuselage. Anchor them with short 1 BID tapes wherever necessary.

6. We generally attach the #4 ground cable (-) directly to one of the bolts that secures the starter onto the engine. Since the starter will draw the most amps during cranking, we've found that this direct connection does help reduce voltage drops.
7. The #4 (+) cable will attach to a relay mounted onto the upper firewall. This relay should be an intermittent duty type relay (or starter relay). From the opposite large post on that relay, run another #4 cable directly to the (+) post on the starter motor. Starter relays will generally work right side up or upside down and there is no difference between the two large posts, i.e., current can be run through the relay in either direction.
8. A convenient location for mounting the starter relay is high on the left side of the firewall bulkhead. This is best accomplished by potting in bolts from the aft side and applying a floc fillet over the heads along with 1 BID. This will then form permanent "studs" on the fwd face of the firewall onto which the relay can be located. Fixed studs would be required in this location since you would not have access to the upper aft face of the instrument panel unless the header tank / forward deck is removed (and there is little clearance room between the firewall bulkhead and the header tank itself).



C. Power busses for instrumentation, etc.

Unlike aluminum or steel airframes that are conductive, composite airframes are not conductive, thus you will need to locate both a positive (+) and a negative (-) buss terminal. See figure 18-1. All electrical devices will require both a (+) and a (-) wire. The negative leads can however be grouped into common wires provided they are properly sized for the cumulative amperage of all items on any such common ground lines.

1. There are several relatively easy installation locations for the busses. One such location is on the right side of the header tank's aft face. See figure 18-4. An easy approach is to use a simple "strip" terminal. These will have a variable amount of terminals that can be cut to any desired size. They then attach into a custom base adaptor which can be screwed to "studs" that have been bonded to the tank wall. (AMP corporation makes such strip terminals and are available at many aircraft supply houses.)

NOTE: If you have the recommended installation of a removable header tank / forward deck, then it is very easy to locate the buss terminals in their correct position while the fwd deck is removed. Use a piece of wood that is clamped across the longerons in the proper position to simulate the mounting position of the buss terminals onto the aft face of the header tank. Then simply clamp the terminals into position on that temporary alignment board and you will be able to wire the complete aircraft with the fwd deck removed. This provides very easy access to all the wire installations. By the time you have all the wiring attached and tie wrapped, the busses will virtually hold themselves up and in close position.

2. For power to the busses, there are two possible means. The best approach from an electrical "noise" viewpoint is to run separate leads direct from the source (battery for negative and master relay for positive) to the appropriate buss. This will produce less chance of noise entering the system to disturb radios and Loran C units. It will however require additional large gauge wire which is added weight. The gauge of the wire leads will depend on the instrument panel systems added. See the chart on page 18-12 for maximum amperage for wiring.

An alternative approach is to pick up the power at the engine compartment and run shorter leads back to the cockpit busses.



COPPER CABLE CURRENT HANDLING CAPACITY

A/N Gauge	Single Cable Max Amp.	Cable weight	Circuit Breaker (amp)
22	6	N/A	5.0
20	11	.56	7.5
18	16	.84	10.0
16	22	1.08	15.0
14	32	1.71	30.0
12	41	2.50	25-30
10	55	4.27	40-50
08	73	6.92	50.0
04	135	16.25	100.0
02	181	24.76	125.0

NOTE: Cables in a bundle will have reduced amperage carrying capacity.
(Source: U. S. Dept. of Commerce)

BUSS BAR POSITIONING

Figure 18-4

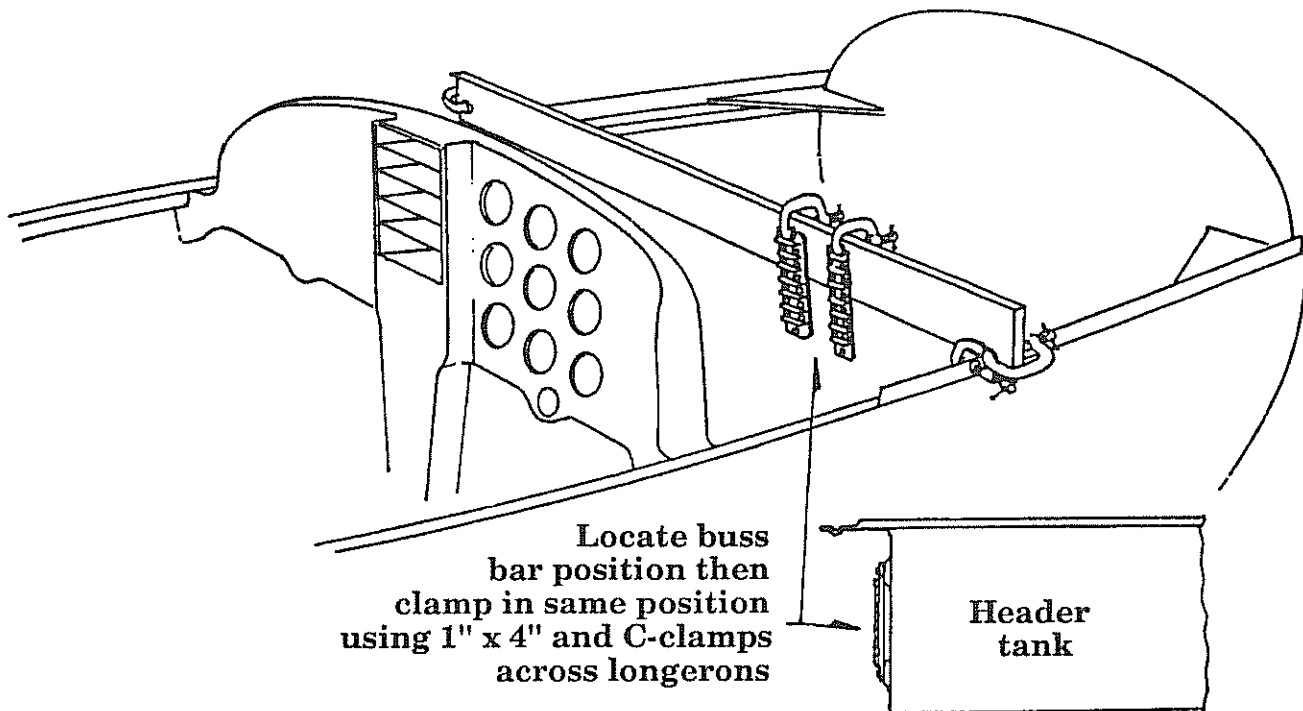

3. It is recommended that you install an avionics master switch that will connect and disconnect all the avionics at one time. This is recommended since when starting, the alternator can produce large "spike" loads that can be detrimental to the avionics. Always start the engine with the avionics master in the "OFF" position and switch it "ON" after the engine is running. Without the avionics master switch, if you have a relatively sophisticated avionics installation, you would have to turn each item on and off separately, and that process could be inconvenient. If you are setting up a single radio, VFR package, then such an avionics master is obviously not needed.

Also, with an avionics master, you can more easily separate the avionics from other noisy systems such as strobe lights, trim motors, etc.



D. Flap Wiring

The Lancair flaps are driven via the 12V electric linear actuator. Also the limit stops are set by the custom limit stop (micro switch) assembly that mounts directly over the actuator shaft. It is operated by magnetic reed switches.

1. There are two DPDT (double pole, double throw) relays required to connect them. Also a DPDT Momentary On switch is needed to operate the flaps. Since many builders seem to have different preferences for their type of flap switch, we have not included that switch as standard. The two relays are included as is the complete micro switch, limit stop assembly.
2. See figure 18-5 for the flap wiring. If you have trouble interpreting the schematic, don't worry, the additional drawings will take you through this installation in a simple pictorial manner.

FLAP MOTOR WIRING SCHEMATIC

Figure 18-5

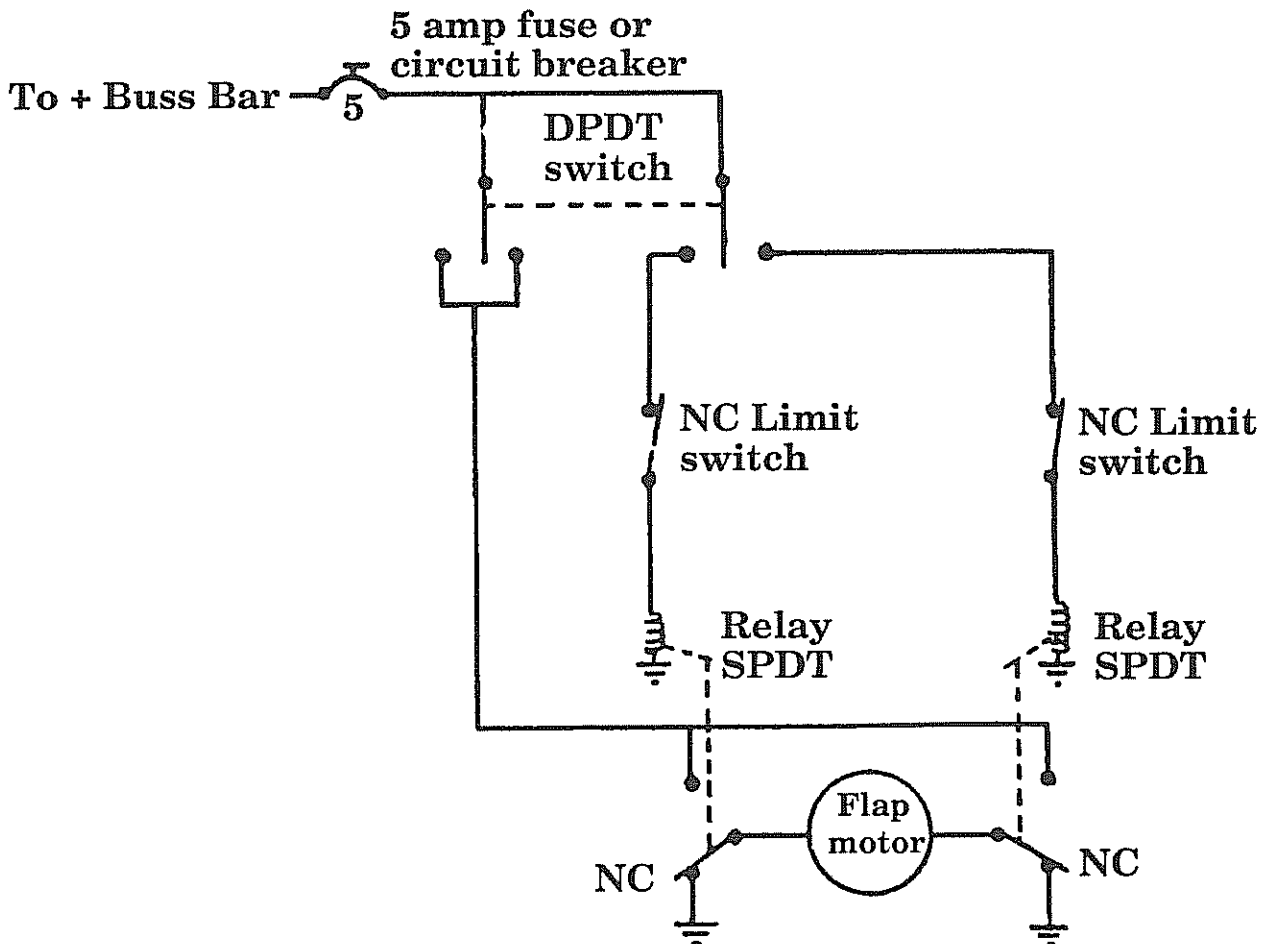

3. The two relays are easily attached to one of the bulkheads that isolate the flap motor itself (behind the pilot's seat). These two relays can be located together with a silicone bond and wire tied into position against the aft close off panel, see figure 18-3.
4. Per figure 18-6, connect the wiring to these relays and attach the wires to their respective locations. The "spade" connectors on the relays are 3/16" in size. Use #18 wire.

NOTE: There are 4 wires that will travel fwd to the instrument panel:

1. Ground
 2. Up limit switch
 3. Down limit switch
 4. Positive (+) to the relays.
5. Secure the wires well so that they can not possible get tangled up with any of the flap actuator movements.
 6. Before wiring the relay / flap motor assembly it is important to first establish the proper polarity of the motor. Or put another way, you must determine which wire on the motor is (+) when the actuator is extending. By placing one of the motor leads on (+) and one on (-) on any handy 12V battery, locate the correct combination that extends the actuator shaft. Mark that appropriate wire (+) for future reference. This extension movement will act to bring the flaps DOWN.
 7. Attach the limit switch assembly to the actuator shaft. (The final position will be determined later, but for now, just put the magnetic reed switches on opposite ends of the base bracket - not all the way to the ends though.) The limit switch that is at the far end of the shaft (away from the motor) is the one that will limit the flaps DOWN position.
 8. For the sake of discussion, let's pick relay #2 as the one to be used for flaps DOWN. The other relay will be used for flaps UP. With this established, the wire marked "Limit Switch #2 on relay #2 is connected to that limit switch. See figure 18-6. Also, the wire on relay #2 marked "to motor" must be connected to the flap motor wire which was earlier labeled (+). Now we have the motor turning in the correct direction for flaps DOWN and the motor will be stopped by the correct magnetic reed switch (or limit switch).
 9. The flap control switch has two possible wires that could connect to the above limit switch #2. See drawing of a typical control switch in figure 18-8. Either wire can be used on limit switch #2, this will however determine which way the flap control switch moves to extend the flaps. Naturally, you want the movement on the control switch to be either "downward" or "aft" when dropping flaps. If the direction ends up being opposite, just turn the switch around in its instrument panel mounting hole.



FLAP RELAYS

Figure 18-6

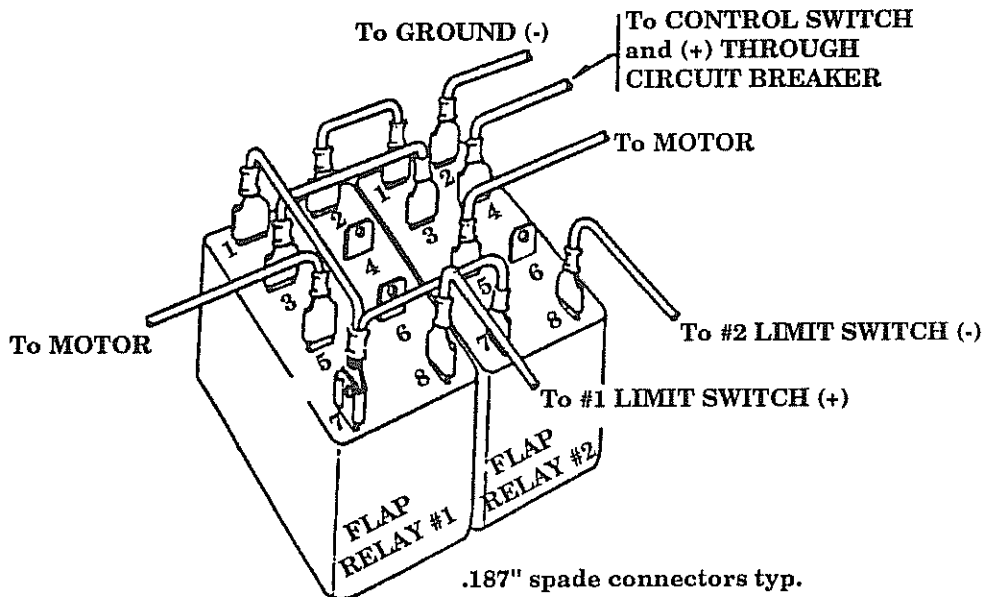

Flap relay schematic

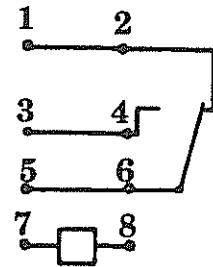

10. The magnetic reed switch will have three possible contact points. Use the center contact and ONLY the contact labelled "W".

NOTE: When setting the wiring for the limit stops, calculate extra wire so that you will be able to fit the custom dust cover over this limit switch installation and be able to route all the wires through its exit hole which is on the END.

11. After completing all the wiring, test run the system and check for two things:
- The limit switches must stop the travel in their respective directions;
 - The motor must be self braking. That is, when you release the control switch, the motor should stop quickly instead of gliding or coasting for two or three seconds. Such coasting is not acceptable and will not occur if everything is wired correctly.

FLAP REED SWITCH

Figure 18-7

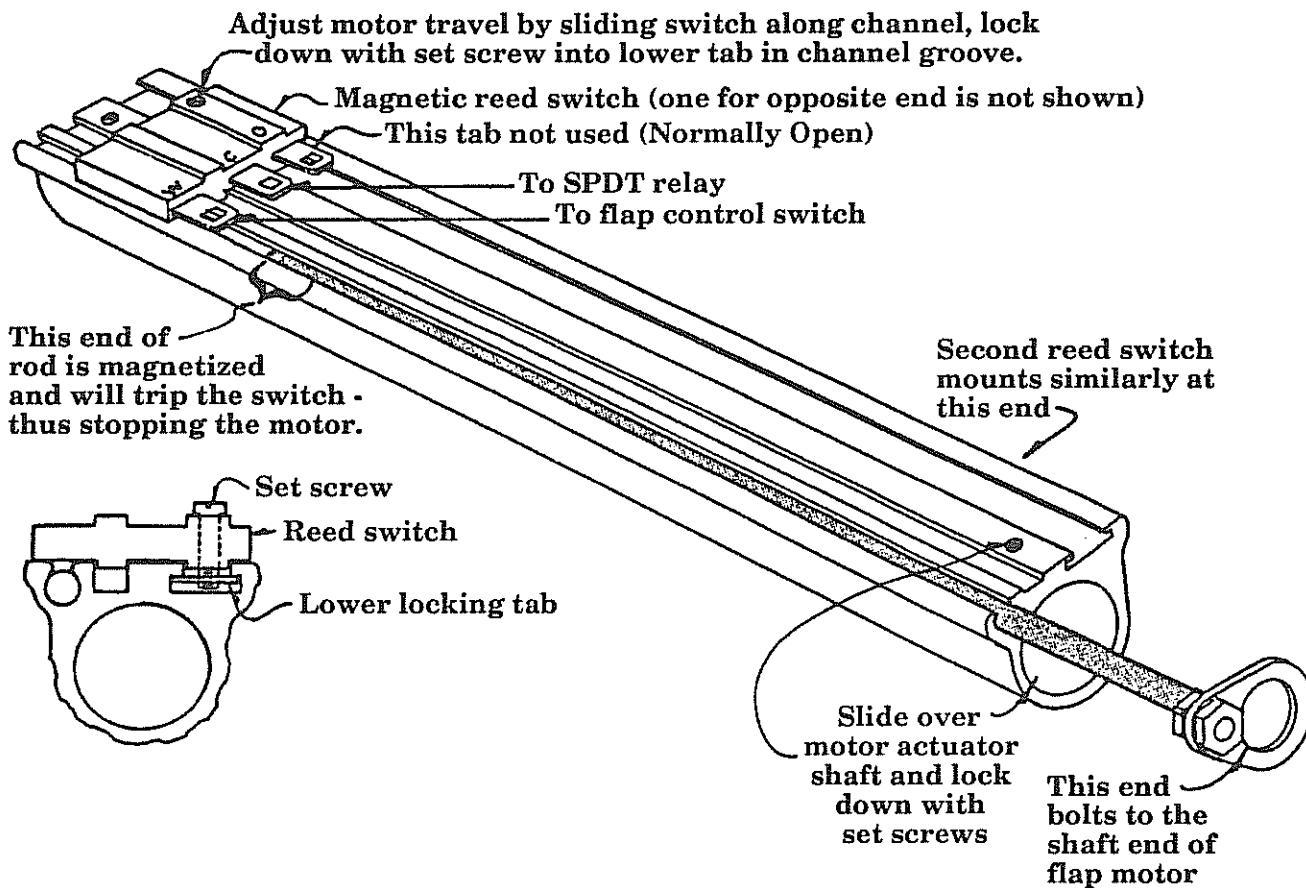

FLAP WIRING LAYOUT

Figure 18-8

TYPICAL FLAP CONTROL SWITCH
must be DPDT, momentary ON switch

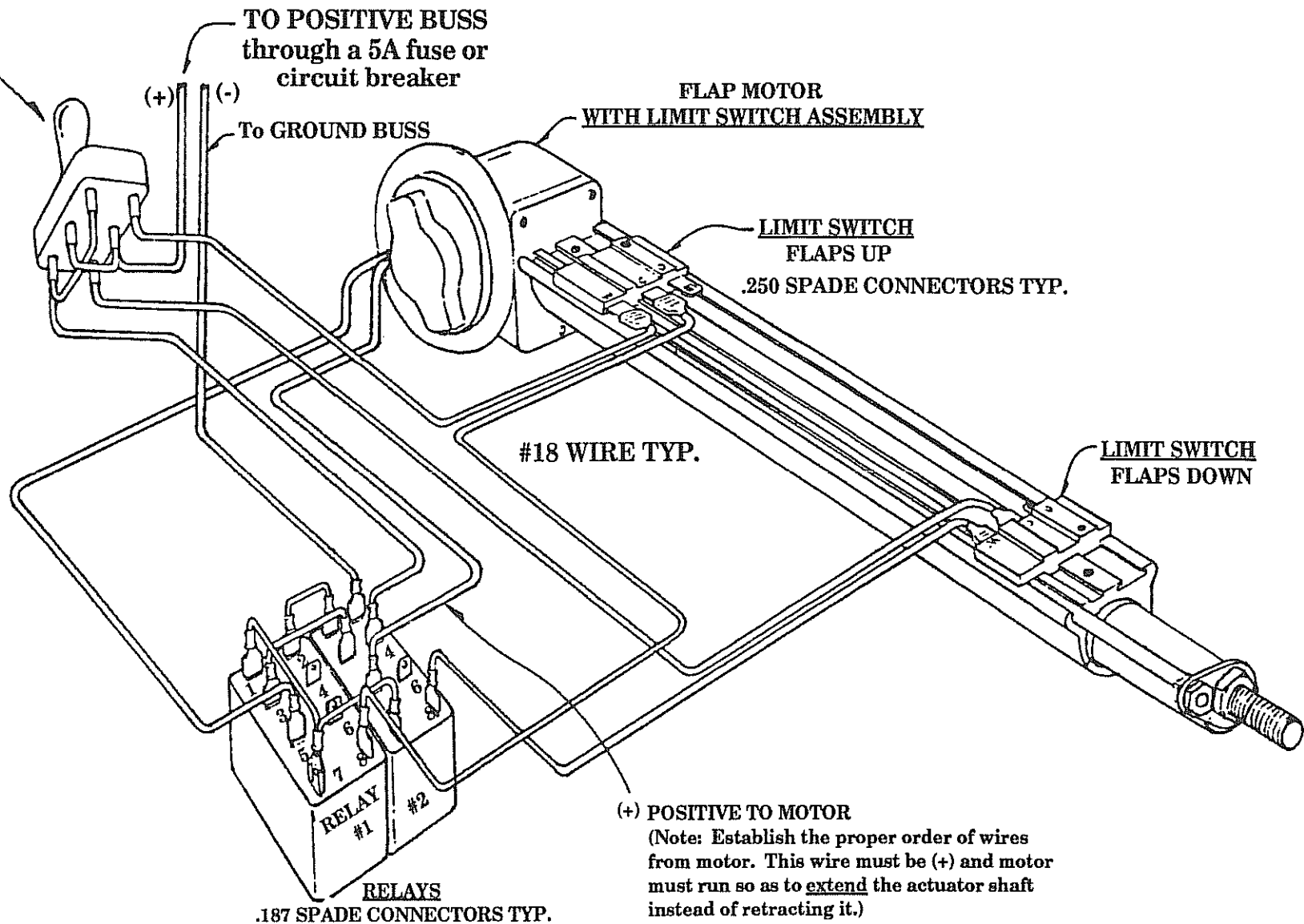

TO POSITIVE BUSS
through a 5A fuse or
circuit breaker

(+) (-)

To GROUND BUSS

FLAP MOTOR
WITH LIMIT SWITCH ASSEMBLY

LIMIT SWITCH
FLAPS UP
.250 SPADE CONNECTORS TYP.

#18 WIRE TYP.

LIMIT SWITCH
FLAPS DOWN

RELAYS
.187 SPADE CONNECTORS TYP.

(+) POSITIVE TO MOTOR
(Note: Establish the proper order of wires
from motor. This wire must be (+) and motor
must run so as to extend the actuator shaft
instead of retracting it.)



E. Setting the flap limit stops

1. When adjusting the DOWN limit stop, run the flaps to the proper down limit position (measured as 8-3/4" down from the faired-in position). This dimension is measured at the inboard trailing edge of the flaps, adjust the limit stop until it disconnects power when the flaps reach that position.

The UP limit stop should be set to the faired-in position (which is -7° on the Lancair 320's). The 320's are designed to be faired in for cruise which is actually a 7° reflex for the airfoil. Thus for takeoffs, you will appear to visually drop 10-12°'s of flaps and slowly fair back in for cruise settings.

2. When it is all adjusted properly, check that the limit stop screws are snug and check that the hex nut that secures the clevis onto the flap motor is also tight against the clevis.

WARNING: If the flap clevis check nut is not tight, it could allow the actuator shaft to turn in the clevis. This could eventually thread the actuator out of the clevis and cause a total flap failure. Be sure to set this check nut.

3. The limit stop assembly is provided with a dust cover that can be wire tied over this installation. A couple of dabs of silicone will also help secure it in position.

FLAP MOTOR ENCLOSURE

Figure 18-9

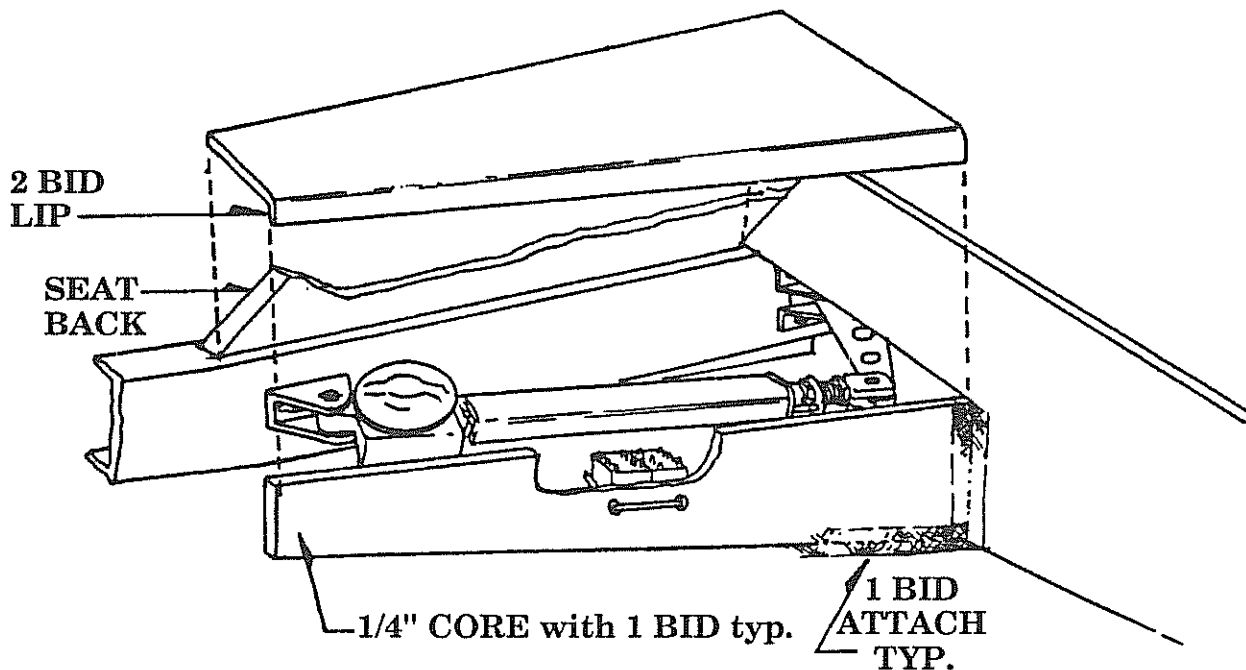

THIS CONCLUDES THIS CHAPTER

LANCAIR® 320FB

18-19

Chapter 18

REV.

0 / 11-1-91

General & Flap Electrical Systems

CHAPTER 19: FINISHING TECHNIQUES

REVISIONS

From time to time, revisions to this assembly manual may be deemed necessary. When such revisions are made, you should immediately replace all outdated pages with the revised pages. Discard the out dated pages. Note that on the lower right corner of each page is a "revision date". Initial printings will have the number "0" printed and the printing date. All subsequent revisions will have the revision number followed by the date of that revision. When such revisions are made, a "table of revisions" page will also be issued. This page (or pages) should be inserted in front of the opening page (this page) of each affected chapter. A new "table of revisions" page will accompany any revision made to a chapter.

Arrows

Most drawings will have arrows to show which direction the parts are facing, unless the drawing itself makes that very obvious. "A/C UP" refers to the direction that would be up if the part were installed in a plane sitting in the upright position. In most cases the part shown will be oriented in the same position as the part itself will be placed during that particular assembly step. However, time goes on and changes are made, so careful attention should be paid to the orientation arrows. That old cartoon of the guy agonizing over the plans for his canoe, built one end up, one end down, should not happen in real life. Especially to you.

CONTENTS

1. INTRODUCTION
2. PROCEDURE:
 - A. BID TAPES
 - B. MIXING MICRO
 - C. GENERAL SURFACE PREPARATIONS
 - D. PRIMING MATERIALS
 - E. PAINTING
 - F. PAINT PREPARATION
 - G. BASE COLORS
 - H. TRIM COLORS
 - I. INTERIORS
 - J. UPHOLSTERY



1. **INTRODUCTION**

The final look of your airplane is obviously an important aspect. It will affect performance but its primary effect is on ones ego. Luckily, it is not difficult or expensive to achieve an attractive finish on your Lancair, after all, you're starting with the best looking airframe in the air! Some very simple hints and techniques are all it will take.



2. PROCEDURE

A. BID Tapes

1. The BID tapes that are applied to the exterior joggles will naturally require the most finishing and a little blending.

One simple trick in starting the process off is to apply an epoxy/micro blend (heavy on the micro here) to the tapes within just a few hours of application. When the tapes are still tacky, mix up a small batch of micro and apply it to the joint area. Be sure that the tapes are set up enough that you won't disturb them with the application of micro. Of course, you can always wait until they are fully cured, that's perfectly acceptable.

You'll probably find that it is a good idea to perform the basic finish on the BID tapes as you progress through the assembly of the airframe as opposed to waiting until all the glass work is completed and then starting on the finish. If you break it up a little, the task will seem much easier and in fact it will likely *be* easier.

2. As you are progressing through the assembly processes, you will usually have some excess epoxy mixed up from time to time and it should not be wasted. Simply mix it with generous amounts of micro and find a BID tape somewhere that can use it.



B. Mixing the micro

1. When you are applying the initial micro to an area, you should mix it quite thick. Thick means LIGHT and inversely thin and runny means HEAVY. The thick micro should have the consistency of bread dough (or perhaps just a *little* bit less thick). You might next experience a bit of difficulty in the application of this thick micro. It may want to roll up behind your squeegee. If that proves to be an unsolvable problem, then perhaps it is just a little too thick, thin it back down with a little more epoxy. (But always premix the epoxy thoroughly before adding it to an existing batch of epoxy/micro.)

One final method of evaluating the micro blend is by its sheen. If it smooths out, sags or runs on vertical surfaces and/or achieves a nice smooth shiny look to it as it sets up, then it definitely is too thin. You can usually determine this quickly after an application since it will quickly smooth out and get shiny on the surface. If you see that, then you will still have time to remove it and add some more micro to the mix and reapply. Generally, one or two applications will be all that is required to "get the hang of it". And that's why it is best to start with small areas first so if you didn't quite get the blend figured out, you won't be stuck with large areas to deal with.

2. In general, the first applications of micro will be the thickest mixture. As you apply a second coating for "fine adjustments", the mixture should be somewhat thinner since you don't need much "build" and you don't want to trap any air bubbles in the mixture. Any trapped air bubbles, if they are too large or too close to the surface can result in popping the paint loose in that small area as the air in the bubble heats up, expands and loosens the grip of the finished paint. That's obviously of no structural concern but you sure don't want any shiny bumps in your otherwise smooth paint job.
3. The micro will often take a couple of days to cure. It has such an insulating effect on the epoxy it's mixed with that the epoxy tends to cure much more slowly than it would with no micro mixed in. Again, heat will play a major role in the cure time, basically, the hotter the better - up to about 200°F that is. At that temperature, it's just a couple of hours! And luckily, your Lancair is about the only composite kit plane on the market that can take that kind of heat with no structural damage, in fact we always recommend such a post cure since the laminating resin will also post cure to 197°F.



4. If you want to post cure or accelerate the micro cure so you can proceed with sanding, simply lay a tarp over the area (supported off the micro, of course) and place a small space heater under it. Be sure to protect it so that a fire can not start on the tarp. This will create a mini-oven and achieve a nice, fast post cure. The smallest available space heater will work very well. And you don't have to worry about a fire starting in the prepregs, unlike the vinylester kits that are common on the market and burn with a fury, your Lancair's prepregs will not sustain a flame at all.
5. When you're ready to first sand the micro, use a 50 grit paper on a long board. These "long boards" are available in any auto body repair shop and use the standard 3" x 14" sanding sheets. It's a good idea to buy a pack of 50 grit and 80 grit.
6. You should always sand on a 45° angle to the contour and run the sanding board in a bit of a diagonal direction. Also, change directions of stroke regularly so that you achieve a nice smooth transition across the BID tapes thus not generating any grooves or waves.
7. If you start with a 50 grit sandpaper, you should use that to only get the lumps and bumps off of the micro then switch to an 80 grit to get down to a nice smooth blend. Any second applications of micro will usually be best treated with only 80 & 120 grit.
8. A small 3" x 6" sanding block is also quite helpful as is a "half round" sanding board. The half round is used along sharply rolled surfaces like at the wing to fuselage joggles, etc. The half-round sanding boards will use 1/4 of a standard sheet.
9. With micro well dressed over the BID tapes, etc., you're ready for primer.



C. General surface preparations

1. As mentioned above, the general means to attaining good smooth transitions is with micro. Small spot touch-ups can be made easiest with the light weight body fillers available in auto supply stores. Use only the light weight types (typically about 5-7 lbs. per gallon), these will have micro balloons mixed into them already - but to a much lesser degree than with our epoxy/micro. This type of filler should NOT be used in large amounts, but only for small touch up areas. It dries very quickly and thus allows for final prep on a fast basis.
2. To achieve the best possible adherence of paint, all surfaces should be cleaned with a suitable cleaner to remove dirt and oils. After cleaning, sand the surfaces with 80-120 grit prior to applying any primers.



19-6

Chapter 19

REV. 0 / 11-1-91

FINISHING TECHNIQUES

D. Priming materials

The best filling primers are of an epoxy basis. The lacquers should generally be avoided. Polyesters are acceptable, however they will shrink and the shrinkage will allow imperfections to eventually begin to show through the finished paint job. Again, epoxies are highly recommended.

We have tested a wide variety of filling primers. There are surely many excellent types available that we have not had the opportunity to test out, however we have found one that does work very well. It is our WLS system and is generally stocked by Neico, consult our options catalog.

The WLS system is a two part epoxy system and can be reduced by up to 30% for thin applications. When applying the last coat of primer, it is generally best to thin it. Thinner / reducer is supplied with each WLS set.

1. The first application of primer is primarily to fill the small depressions in the weave. These are very shallow and are very small. It is generally effective to first squeegee a filling primer onto the surfaces, this helps to get the material down into the tiny depressions. Do not bother to sand this, simply allow it to dry and follow up with a standard spray application of filler / primer. Allow that to cure.

If you were to spray a heavy first application of filling primer onto the surfaces, it could tend to bridge the small depressions and, when it was sanded back down, the bridging would be sanded away and the depression would reappear. One first spray technique does work satisfactorily. Spray a very light coat and allow it to set up a bit, then follow with another very light coat. These coats should be so light that it requires about four passes to get a solid color change. Then allow that to cure. This process helps allow the filling primer to get into the depressions and exclude the air that must be displaced without causing any bubbling on the surface. If you see any bubbles occurring, it is because the primer is displacing small amounts of trapped air which causes a bubble in the too thick application of primer.

2. After cure, use either a machine sander or sand it by hand. Start with 120 grit and progress up to 150 grit for this sanding (if you are careful, you can speed the process by starting with 80 grit, but don't sand with that course of a paper too long or you'll not have anything left to sand with the finer grits.). This sanding will go quite quickly since you are not doing any contour work, just knocking down the primer. We generally will sand an entire wing surface down in about 30-40 minutes. An air driven dual action sander (DA) will work the best. Use the 8" diameter size. The 6" orbital sanders will take *much* more time. The 8" DA will require a 2 hp compressor and it will work that compressor pretty hard, but it usually can just keep up with the air demand. Keep the sander moving and use a similar diagonal motion so that no grooves or waves result.



3. You should sand this application down until you just begin to see the cream color of the prepreg starting to show through.

NOTE: It is very important to keep the primer applications THIN. Excess amounts of primer could easily increase the weight of your aircraft by as much as 30 lbs.

Also, remember that the goal should be to achieve a finish on the bottom surfaces that is conducive for good aerodynamics *only*.

4. With that first application of primer sanded down, go over the surfaces and look for imperfections. Use a spot light at a low angle to the surfaces in a dark room to quickly point out any imperfections. You should use compressed air to blow off the surfaces first. Wiping them will leave sanding material down in any imperfections and you'll miss seeing them.
5. Apply a second coat of primer. This coat can be a thinner application. After cure, sand it down with 220 grit. You can either wet or dry sand. If you wet sand, the sandpaper will not tend to clog up (use 3M wet / dry - black sandpaper). However, with wet sanding, you should allow at least one to two weeks for the surfaces to fully dry before painting. If you dry sand, use the aluminum oxide sandpaper (light grayish color).
6. If you are intending to use a urethane type of paint, then generally a 220 grit finish is acceptable as a paint base. If you choose an acrylic / enamel type of paint, you should go to a 360 grit finish since it will show the scratches more readily than a urethane.
7. The second coating of primer should also be sanded down quite thoroughly. If you begin to show the prepreg through, spray a touch-up with primer and lightly resand the touch-ups. This will assure the thinnest possible primer coat, yet allow full coverage.
8. If you have some (few) imperfections located after everything else is readied for paint, limited use of a lacquer spotting putty is acceptable. This should be used sparingly. It is packaged in a tube and will set up in about 20 minutes. Use a small squeegee to apply it, then spot sand with 220 grit. Make sure that it is feathered out nicely or else an edge will result and show through in the paint. The two part spotting putties are much better though and will set up equally fast.



E. Painting

This is not intended to be a painting instruction, we will only touch on a couple of basics. You should consult local sources or available technique books for tips on painting.

1. Generally, the urethane paints are preferred. That is because they will allow the greatest amount of flex without cracking or chipping. You will generally use less spraying volume of them but they are heavier, with less evaporative solvents, so the weights come out about the same in the end. Imron is the most readily identified name brand but there are several excellent brands available such as Sterling and Ditzler.

Another acceptable type is the acrylic / enamels. These, when used with the catalyzed hardeners, produce an excellent finish. One such paint type is DuPont's Centari. Often, the acrylic / enamels are easier to touch up and blend in with the existing paint finish. The urethanes often do not blend very well together when making any spot repairs. On aluminum, (rivet-bucket) aircraft, that problem is more easily dealt with since you could mask off individual panels. But, with our composite airframes, there are no "panels" since all parts are fully flowing and blended into one another and thus there is simply no convenient place to stop a spot repair short of an entire wing surface or fuselage.

2. A word of caution, when preparing to paint, be sure to read the safety instructions and follow them carefully. The fumes from these paints can cause serious harm. Among other precautions, you **MUST** wear a good charcoal filtering type respirator with new cartridges installed.



F. Paint preparation

1. It is generally recommended to disassemble the airframe as much as possible for painting. This will make for more pieces but a better paint job when it's all put back together.
2. Remove the control surfaces, gear doors, wings, canopy and cowling. Mask off all appropriate areas. Tape off the gear wells and wrap plastic bags around the wheels. If you roll the plane up onto some stands, the lower surfaces of the fuselage will be easier to spray but be sure that you can still reach the top or have a stool available.
3. Blow off everything with compressed air and be extra careful to blow off areas that are near any possible spray gun blast even if they are not destined for paint such as in the gear wells, back by the flap attach locations along the aft spar webs, etc. Sometimes these areas can have big cakes of dried sanding residue that is just waiting to be launched into the air when your spray gun hits it. And that can make a huge mess on a nice clean, wet paint surface. Also check the hose near the area of the spray gun since it will likely be suspended over some wet paint as you make your spray passes.
4. Wings, control surfaces, etc. can be hung on wires or clamped up to make-shift fixtures. Again, be sure these fixtures are also dirt free.
5. It's not easy to paint all surfaces at the same time but it is recommended to at least mix all the paint cans so that the color is guaranteed to be identical from one gallon can to another.

Generally, two gallons of top coat paint (plus its recommended thinner and catalyst, etc.) is sufficient. So, mix the two gallon cans together by pouring them into a bucket, mix them and then pour them back into their own gallon cans again. Even though the colors are supposed to be the same, they often have slightly different hues from one can to another. Whites are particularly susceptible to this problem.



G. Base Colors

1. Keep your color choices to **LIGHT pastels ONLY**. Yes, you've seen other darker colors on aircraft and one of our company planes has had a darker color but that was for a testing program and **IS ABSOLUTELY NOT RECOMMENDED**. **In fact by policy, we prohibit dark base colors on all Lancairs.**

Yes, our Lancair materials are better suited to higher thermal tolerances but as with all composites with any type of resin system, strength will drop as temperature rises.

The biggest difference with Lancair materials involves the core materials. Our high temperature cores will not sustain any permanent damages from elevated temperatures, the common low temp cores would. However, if you are using the white Clark foam for ribs and bulkheads, it is **NOT** a high temperature core and must not see elevated temperatures. If you have chosen to use the optional high temperature prepreg bulkhead sheets, then it will tolerate elevated temperatures without any permanent damages but, as with all resin systems, a temporary strength drop will result as temperatures rise. This temporary drop reduces the effective safety margins until the composite cools.

When it cools, all strength will return. But, due to this temporary, potentially in-flight drop in margins, we only recommend light pastels for a base color. We cannot stress the importance of this enough. Keep your colors **LIGHT** and let us do the testing.

However, with your Lancair, you can enjoy a much wider color choice than any other kit plane on the market since all the vinylester / low temp foam kits should **ONLY** be painted white since any other color choices, even light pastels, could run their expected surface temperatures too high thus causing permanent structural damages. This will never happen with your Lancair and it is just one of the many reasons why we have chosen these superior, high temperature advanced composites for the Lancair. That is also one of the key reasons why virtually all of the commercial composite industry uses **ONLY** high temperature epoxy based composites for airframe applications.



H. Trim colors

1. There really is no problem with any of the trim colors provided you keep them down in size. It is recommended that you not paint any trim on the fwd 50% of chord along the wing. This is because the resultant paint edge, even though it might only be .010" thick, could trip the laminar flow and cause added drag. Fwd / aft orientated wing tip striping is however acceptable.
2. Generally, the trim is painted onto the airframe after the base coat has been applied. Usually, the more simple the trim design, the better it looks. Designs that have a lot of vertical direction changes within them generally tend to break up the smooth flowing lines of the Lancair and detract from it in the process.
3. It is highly recommended that you use the 3M type "fine line tape" for masking the paint areas. This should be used for the base coat colors as well, such as around the canopy and windows, etc.

This fine line tape is usually found to be slightly greenish / gray in color and of a mylar type material. It is much thinner than the masking tapes and produces a very nice, crisp line.

WARNING: When you are finished with the painting, etc., be sure to check your pitot and static ports, especially the static. Verify that it is still clear and functioning as primer and paint could plug it up.



I. Interiors

1. The interiors of the aircraft are generally painted and upholstered. The primary point here is to stress the importance of covering ALL exposed surfaces of fiberglass with either paint or upholstery or both. The fiberglass must be shielded from ultra violet rays to insure longevity of the structure.
2. The inside of the canopy frame is generally finished with micro, primered and painted. This is usually applied to the longerons and around the canopy latches as well since the upholstery panels will generally tuck under the longerons on each side and are cut out around the canopy latches.
3. In the baggage compartment, the side walls can be either upholstered or painted. Paint is cheaper and lighter but will allow for more noise to bounce around in the cabin during flight, upholstery looks better but it's heavier, and more costly. The same thinking applies to the upper "head liner" in the baggage compartment. Painting it is probably the more standard approach. We generally then use simply a filling primer and paint it with Zolotone paint. This type of paint is also referred to as "trunk paint". However, most trunk paints that come in rattle cans (aerosols) are not nearly as attractive as the Zolotone brand of speckle paint. This type has smaller flecks and looks very attractive. It also hides a lot of "sins" since it covers very well. With these types of paints, there is no need to sand beyond the 80 grit stages.
4. Once again, it is recommended that these interior colors be kept to light pastels as well. Also, on a hot day, you will definitely appreciate a light colored interior. However, the instrument panel should be painted with a darkish color. The canopy will have the ability to reflect the instrument panel and a light colored panel will really distract from good visibility along the lower fwd portion of the canopy during certain natural lighting conditions.



J. Upholstery

1. A nice upholstery need not be elaborate to look good. What is most important is that you use materials that are suitable for an aircraft interior. The important issues are fire resistance, toxic smoke given off and weight. Interiors can become very heavy if you are not careful in your upholstery selections. Carpeting can be particularly heavy but luckily, there is not much in the way of square feet of carpeting required. Seat cushions can range from 1 lb. to over 5 lbs. depending on type of foam cushioning and type of fabric chosen so think "weight" when selecting upholstery.
2. Seat cushions and back cushions should be removable. A velcro strip will secure them to the front of the main spar web. The seat back panels can simply lay against the seat back bulkhead and a panel attached that wraps around the top and attaches with velcro under the top support. Side panels are generally self contained panels that are glued into position. If you run the side panels fwd under the instrument panel about one foot, the look will be better. Also a small side close out panel on each side of the nose gear tunnel that extends back and attaches to the sides of the instrument panel make for a nice finished look. Make an oval cutout for where the free-fall valve is accessed from the pilot's side.
3. From the instrument panel forward, we generally cover the sides of the fuselage with a sound proofing material along with the complete nose gear tunnel and the back of the firewall bulkhead. The nose gear tunnel is a particularly important item onto which good sound proofing is important for a quiet cabin. Also the "D" section of the stub wing can become a sounding box and it should be closed off from the cabin area with a bulkhead and soundproofing.



1. **INTRODUCTION**

Well, this is the moment we've all been waiting for. After all those hours of building an airframe as LIGHT as possible, the proof is on the dial! Of course, the weight not only has to be about right, but it must also be in the right place. Proper CG is absolutely critical to safe flight. This is where NO exceptions can be considered, you must verify that the center of weight is in the correct position and if it is not, you must correct it.

Individual builders' preferences, techniques, etc. can play a major roll in placing the initial empty CG of the airframe which is why we suggest that you make some preliminary weight and balance calculations during the latter part of assembly and prior to installing the battery since the battery is an excellent tool to use in adjusting the empty CG of the completed airframe.

Spend a little time to prepare a nice weight and balance sheet since the F.A.A. will require this for your airworthiness certificate. You should run several weight and balance calculations for a variety of loading variations. We have supplied you with three blank weight and balance sheets. For the following, you'll need a good (repeat GOOD) set of scales. Bathroom scales are simply not good enough.





2. PROCEDURE

WARNING: Do not attempt to calculate the center of gravity using common bathroom scales. They are not accurate enough for these expected weights and will give false reading. Flying outside of the approved center of gravity envelope could be dangerous.

You should borrow or rent for a day, a good set (3) of accurate beam scales or equivalent. These scales should be able to accurately handle up to 400 lbs. each. Often, a local EAA chapter will have a set or know where you can locate a set for use. Also, many FBO's have them.

1. First establish the airframe's empty weight and its empty center of gravity (CG). To do this you'll need to establish the aircraft as "level" while sitting on all three scales. This will require shim blocks under the main gear. These shim blocks can be 1x4's or similar, their weight will be referred to as "tare weight". That tare weight will always be deducted from any readings on its scale.
2. Establishing this empty CG is very easy once the aircraft is placed on the scales and levelled with shim blocks.

NOTE: If you have not installed the battery yet, that's fine. You will later weigh the battery and its installation hardware, etc. and easily calculate where it should be placed. Or, you could actually place the battery in the desired locations in the plane and read the weights.

WARNING: Be sure to conduct this weight and balance test indoors or on a very calm day. Even the slightest breeze can generate a few pounds of lift over the wings and totally ruin your accuracy. The ground base should also be flat and level.

3. Next, establish a "datum point". This is a point from which all measurements will have to be taken. The actual location of the datum is not important. What is important is that your selected datum point is easily determined and ALL measurements are from that same point. For convenience, we suggest the back edge of the spinner.
4. From your datum point, drop a plumb bob and mark a point on the floor where the plumb bob centers. Mark a centerline for the aircraft down along the floor as well. You can quickly do this by dropping a plumb bob line at the tail and then connecting the two points with a straight chalk line. The spinner center will actually be slightly right of center line but that's o.k., it's close enough for its intended purpose.



	20-3	Chapter 20	REV.	0 / 11-1-91	
		WEIGHT AND BALANCE			

5. Drop a plumb bob down from the center of each wheel axle. Mark the nose gear axle center onto the ground at the centerline position. Mark the two main gear axle centers onto the ground and extend a straight line connecting the two, then mark that location where it crosses the fuselage center line that was previously marked onto the ground.
6. Read and record the actual weights of the leveled aircraft on the three scales. Log these weights in the appropriate lines of column A.
7. Log the weights of any shim stock that is on the scales (1x4's, etc.) as tare weight in column B.
8. Subtract the tare weights from the measured weights and place those figures in column C.
9. Next measure and record the distance from the datum point to the nose gear. Measure and record the distance from the datum point to the location of the main gear as marked along the fuselage center line. Log these distances in the appropriate lines of column D. These are the "moment arms".
10. You now have all the information necessary to establish the empty CG.
11. You will now need to arrive at the "moment weights" of the nose gear location and the main gear location. To do this, simply multiply the weight of the nose gear by the distance from the datum point. Record this number in column E. Do the same for the main gear.
12. Total lines C and E separately.
13. Now simply divide column E by column C and you will arrive at the empty weight CG, expressed as a distance from the datum point.

This empty weight CG must ultimately be forward of the allowable CG since when the pilot gets into the aircraft, he will be aft of this point and that will move the CG aft into the beginning of the allowable range. You want to establish the empty CG such that when the plane is in its most nose heavy condition (full header tank and just the pilot in the plane) the CG is at the front limit.

Allowable Center of Gravity is from FS 24.5 to FS 30.3

You'll now need to locate FS 24.5 and FS 30.3 thus establishing a moment arm for them so that you can reference your actual CG in meaningful terms. This is not hard to establish.



14. There are two easy references:
- a.) The back face of your firewall is FS-0 and is easily located through the nose gear well. Drop a plumb bob line down from that point and mark it onto the centerline on the floor. (This line will likely be on the nose gear scale platform but that's o.k.) Measure from your datum point to this FS-0 mark and record that dimension. You can now easily calculate your particular moment arm required to align with FS-24.5 and FS-30.3.
 - b. The front face of the main spar web is a very good reference point, and that is accessible from inside the cockpit. It should be (if you constructed your plane correctly) 27.5" back from the firewall at, of course, FS 27.5.

You should now, therefore, have established your minimum and maximum allowable moment arms that establish the CG range. Record these moment arm ranges on your CG calculation sheets.

15. Before you remove the aircraft from the scales, it is a very wise idea to also establish your exact moment arms for various loading items such as header tank fuel and pilot/passengers. The header tank fuel can be estimated with quite close accuracy since it is a well confined shape with known weights. The pilot and passenger moment arms should definitely be determined and not estimated. Factors like seat back angles can greatly affect the overall pilot CG when seated in the aircraft. Estimating body CG could easily be off by two to four inches which would invalidate your flying CG calculations.
16. To determine your pilot/passenger moment arm simply sit in the plane and have someone log the resultant weight changes on the three scales. You'll notice that the nose gear scale weight actually becomes *less* while the main gear increases by more than your known body weight. However, the net change in the aircraft weight will obviously be equal to your exact body weight. (If not, call the witch doctor!)
17. With the weight changes logged on the three scales, recalculate to determine your pilot's moment arm. Lets use an example:

EXAMPLE:

Let's say you weigh 170 lbs. The net change on the nose gear was (-50 lbs.) and the net gain on the main gear then had to be $170 + 50 = 220$ lbs. Multiply the nose gear weight change (a negative number) by its moment arm and the main gear change by its moment arm. Combine those two numbers (moment weights) and divide by 170. (Remember that the nose gear number is a negative number so it will actually subtract from the other.) The resultant figure is the moment arm for your body. Log that dimension as the pilot/passenger moment arms.



18. You can use the above approach to calculate (accurately) any loading units like header tank fuel, wing tank fuel and baggage. It is recommended that you take the time to do so since it is the only means of attaining a truly accurate loading analysis. If you are measuring for fuel loads, accurately add measured gallons of fuel and use 6 lbs. per gallon to calculate the weights.

Fuel weight = 6 lbs. / gallon
Oil weight = 7 lbs. / gallon

19. If you have the battery positioned in the aircraft then the weights will be final and the aircraft's empty CG should be forward of the allowable forward CG limit. This is because virtually all flight load conditions will pull the CG aft. What is ideal is to have the CG located on the forward most point of the envelope when you have a full header tank and only the pilot in the plane. This will be your most forward CG flying condition, all other loads applied will only move the CG aft and as you use the header tank fuel, the CG will again move aft.

The best empty CG position (distance fwd of the allowable flight CG) is determined primarily by your pilot/passenger moment arm. An empty CG about 2" fwd (or FS-22.5) is about right but you should verify this for your own aircraft.

CAUTION: Do not set the aircraft empty CG at the fwd most point of the allowable CG range. This would be wasting available CG range since you would never be able to operate at the fwd CG limit. Thus, it would take less weight in the aircraft to move you out the back of the envelope which is very dangerous and not allowed.

20. Use the battery to establish the empty CG at the most opportune location (about 2" fwd of the fwd allowable CG range). This can be done by physically locating the battery in the aircraft during the weigh in and recording the changes. An easier method is to weigh the aircraft without the battery installed, then weigh the battery (add about 2 lbs. for the battery box installation) and simply calculate that position, you will likely have to compromise a bit since you would not want to stick the battery in the middle of the baggage bay, etc., but this will allow you to come very close in establishing the most desirable empty CG possible.
21. To calculate the best battery location after a weigh in (without the battery installed), follow these steps as shown in a sample calculation.

SAMPLE CALCULATION FOR BATTERY PLACEMENT:

22. 1.) Establish the battery weight (include the master relay and add about 2 lbs. for the box installation). Let's say it's 26 lbs.
- 2.) Let's say your plane weighs 980 lbs. (less battery) & its moment arm calculates to be 56, thus providing an FS-20 location (this assumes a datum point that was 36" fwd of FS-0).



We have calculated that an FS-22.5 empty CG position is ideal and that's what we'll strive for. That will result in an ideal empty weight moment arm of 58.5 including the battery.

980 x 56 = 54,880	Moment Weight (plane less battery)
980 + 26 = 1,006	Final plane empty weight
58.5	Ideal aircraft empty weight moment arm
1,006 x 58.5 = 58,851	Ideal aircraft final moment weight
58,851 - 54,880 = 3,971	Ideal battery moment weight
3,971 / 26 = 152.7	Ideal battery moment arm (or FS 116.7)

23. Thus by the above sample calculation, you would mount the battery at FS 116.7.

24. If you need ballast weights in the aircraft to achieve proper CG, try to use required items such as a tool bag, etc., as the necessary ballast weights. There are ways within the engine compartment to change the weights by using either heavier starters or alternators. The last option should be the addition of useless lead to bring the plane into CG.

25. Now, to illustrate how this can work out o.k., let's pursue this sample problem a little farther. Let's assume that the pilot / passenger moment arm proved to be 83".

26.	170 x 83 = 14,110	Moment weight of pilot (170 lbs.).
	66 x 43 = 2,838	Moment weight for 11 gal. header tank @ 43" moment arm.
	58,851 + 14,110 + 2,838 = 75,779	Total combined moment weight (plane, pilot, header fuel)
	1,242 lbs.	Total combined weight of a/c (plane, pilot, header fuel)
	75,799 / 1,242 = 61.0	Moment arm during this flight condition (or FS-25) O.K.

27. Now you can take all the calculated moment arms for fuel, pilot / passenger and baggage and make several sample loading analyses to verify that you will always remain within the allowable CG range.



28. If you arrive at loading calculations that move the plane out of the allowable CG range then you must placard the plane accordingly so as to not overload it. This is usually found in baggage limit placards. If you have fabricated a rear "hat rack" it should be placarded for a maximum weight since it is so far aft. Generally, 3-5 lbs. is max. so it is quite literally a "hat rack" and must not be used for anything heavier. Run several sample calculations at that extreme aft end (thus long moment arms) to establish good, safe limits for loading. The weight and balance sheets have a sample calculation row. It should be used and recorded. Perform additional calculations as required to verify that you will not inadvertently load the aircraft improperly. According to FAA regulations, one of these weight and balance sheets must be carried in the aircraft at all times.



20-8

Chapter 20

REV.

0 / 11-1-91

WEIGHT AND BALANCE



WEIGHT & BALANCE SHEET

LANCAIR 320

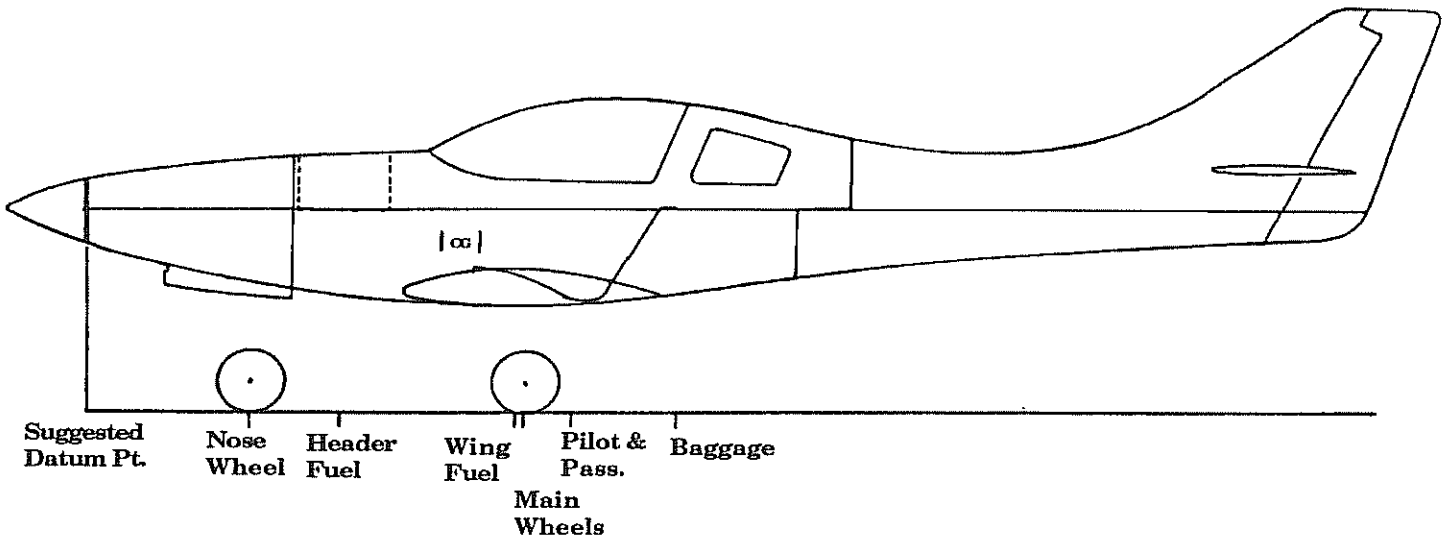

Suggested Datum Pt. Nose Wheel Header Fuel Wing Fuel Main Wheels Pilot & Pass. Baggage

"N" NUMBER _____

BUILDER _____

CG Range: (inches) 5.8" FS24.5 - FS30.3 (Station _____ to _____)

	A	B	C	D	E	Station
	Wt. (lbs)	Tare Wt.	Net Wt.	Moment Arm (in.)	Moment Wt. (in/lbs)	

Nose Gear	_____	_____	_____	_____	_____	
Rt. Main Gear	_____	_____	_____	_____	_____	
L. Main Gear	_____	_____	_____	_____	_____	
Plane Empty CG (with oil)					_____	
						E/C = AIRCRAFT STATION
Plane			_____	_____	_____	
Pilot only			_____	_____	_____	
Header Tank Full			_____	_____	_____	
Maximum fwd CG condition			_____	_____	_____	_____
Plane			_____	_____	_____	
Pilot & Pass.			_____	_____	_____	
Low Header Tank			_____	_____	_____	
Wing Tanks			_____	_____	_____	
Luggage]			_____	_____	_____	
Maximum aft CG condition			_____	_____	_____	_____
Plane			_____	_____	_____	
Pilot			_____	_____	_____	
Fuel (header)			_____	_____	_____	
Fuel (wings)			_____	_____	_____	
Luggage			_____	_____	_____	
Sample condition			_____	_____	_____	_____

WEIGHT & BALANCE SHEET

LANCAIR 320

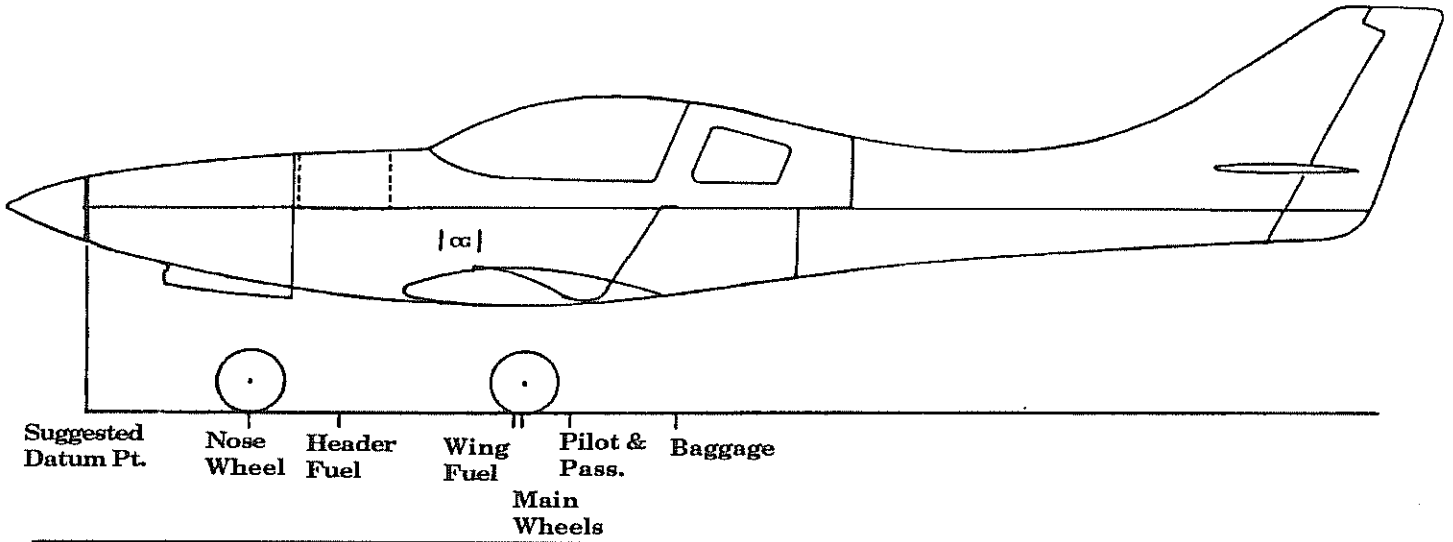

Suggested Datum Pt. Nose Wheel Header Fuel Wing Fuel Pilot & Pass. Baggage

Main Wheels

"N" NUMBER _____

BUILDER _____

CG Range: (inches) 5.8" FS24.5 - FS30.3 (Station _____ to _____)

	A	B	C	D	E	Station
	Wt. (lbs)	Tare Wt.	Net Wt.	Moment Arm (in.)	Moment Wt. (in/lbs)	

Nose Gear	_____	_____	_____	_____	_____	
Rt. Main Gear	_____	_____	_____	_____	_____	
L. Main Gear	_____	_____	_____	_____	_____	
Plane Empty CG (with oil)			_____		_____	
						E/C = AIRCRAFT STATION
Plane			_____	_____	_____	
Pilot only			_____	_____	_____	
Header Tank Full			_____	_____	_____	
Maximum fwd CG condition			_____	_____	_____	_____
Plane			_____	_____	_____	
Pilot & Pass.			_____	_____	_____	
Low Header Tank			_____	_____	_____	
Wing Tanks			_____	_____	_____	
Luggage]			_____	_____	_____	
Maximum aft CG condition			_____	_____	_____	_____
Plane			_____	_____	_____	
Pilot			_____	_____	_____	
Fuel (header)			_____	_____	_____	
Fuel (wings)			_____	_____	_____	
Luggage			_____	_____	_____	
Sample condition			_____	_____	_____	_____

WEIGHT & BALANCE SHEET

LANCAIR 320

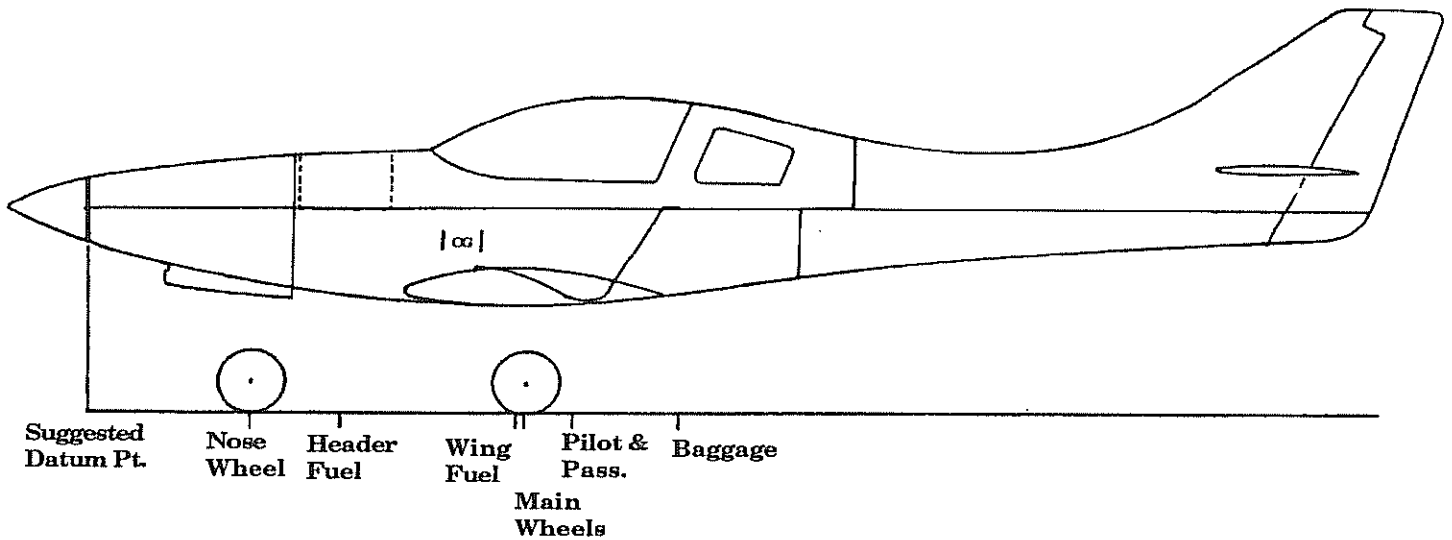

Suggested Datum Pt. Nose Wheel Header Fuel Wing Fuel Pilot & Pass. Baggage

Main Wheels

"N" NUMBER _____

BUILDER _____

CG Range: (inches) 5.8" FS24.5 - FS30.3 (Station _____ to _____)

	A Wt. (lbs)	B Tare Wt.	C Net Wt.	D Moment Arm (in.)	E Moment Wt. (in/lbs)	Station
Nose Gear	_____	_____	_____	_____	_____	
Rt. Main Gear	_____	_____	_____	_____	_____	
L. Main Gear	_____	_____	_____	_____	_____	
Plane Empty CG (with oil)						
					E/C = AIRCRAFT STATION	
Plane						
Pilot only						
Header Tank Full						
Maximum fwd CG condition						_____
Plane						
Pilot & Pass.						
Low Header Tank						
Wing Tanks						
Luggage]						
Maximum aft CG condition						_____
Plane						
Pilot						
Fuel (header)						
Fuel (wings)						
Luggage						
Sample condition						_____

CHAPTER 21 REVISION LIST



The following list of revisions will allow you to update the Lancair 320/360 construction manual chapter listed above.

Under the "Action" column, "R&R" directs you to remove and replace the pages affect by the revision. "Add" directs you to insert the pages shown and "R" to remove the pages.

Page(s) affected	Current Rev.#	Action	Description
21-1	6	R&R	Added section P.
21-2 thru 21-71	0	None	
21-72	6	R&R	Removed text at bottom of page.
21-73 thru 21-79	6	Add	Add section P.



21-i

Chapter 21

6/4-1-99
ENGINE INSTALLATION- LYCOMING

CHAPTER 21: ENGINE INSTALLATION - LYCOMING



REVISIONS

From time to time, revisions to this assembly manual may be deemed necessary. When such revisions are made, you should immediately replace all outdated pages with the revised pages. Discard the out dated pages. Note that on the lower right corner of each page is a "revision date". Initial printings will have the number "0" printed and the printing date. All subsequent revisions will have the revision number followed by the date of that revision. When such revisions are made, a "table of revisions" page will also be issued. This page (or pages) should be inserted in front of the opening page (this page) of each affected chapter. A new "table of revisions" page will accompany any revision made to a chapter.

Arrows

Most drawings will have arrows to show which direction the parts are facing, unless the drawing itself makes that very obvious. "A/C UP" refers to the direction that would be up if the part were installed in a plane sitting in the upright position. In most cases the part shown will be oriented in the same position as the part itself will be placed during that particular assembly step. However, time goes on and changes are made, so careful attention should be paid to the orientation arrows. That old cartoon of the guy agonizing over the plans for his canoe, built one end up, one end down, should not happen in real life. Especially to you.

CONTENTS

1. INTRODUCTION
2. DRAWING LIST
3. EQUIPMENT REQUIRED - SPECIAL PARTS, TOOLS & SUPPLIES
 - A. PARTS
 - B. TOOLS
 - C. MATERIALS & SUPPLIES
4. PROCEDURE
 - A. FIREWALL PREPARATION
 - B. MOTOR MOUNT ATTACHMENT
 - C. NOSE GEAR, FINAL INSTALLATION
 - D. NOSE GEAR BOOT
 - E. FUEL SYSTEM (FIREWALL FWD)
 - F. MOUNTING THE ENGINE
 - G. COWLING INSTALLATION (LOWER COWL)
 - H. COWLING INSTALLATION (UPPER COWL)
 - I. ENGINE BAFFLING
5. LYCOMING O-320 AND IO-320 ENGINE BAFFLING INSTALLATION
 - A. ALUMINUM BAFFLE PLATES
 - B. SPARK PLUG WIRE GUIDES
 - C. RUBBERIZED SEALING STRIPS
 - D. SILICONE SEALING
 - E. OIL COOLER AIR LINE
 - F. MAGNETOS
 - G. REMOTE OIL COOLER MOUNTING
 - H. SPARK PLUG LEADS
 - I. EXHAUST SYSTEM
 - J. CABIN HEAT SYSTEM
 - K. AIR INTAKE SYSTEM (ENGINE)
 - L. PROPELLER INSTALLATION, CONSTANT SPEED
 - M. PROPELLER INSTALLATION, WOOD, FIXED PITCH
 - N. SPINNER
 - O. TACHOMETER
 - P. MISCELLANEOUS PAPERWORK



CHAPTER 21:

ENGINE INSTALLATION - LYCOMING

REVISIONS

From time to time, revisions to this assembly manual may be deemed necessary. When such revisions are made, you should immediately replace all outdated pages with the revised pages. Discard the out dated pages. Note that on the lower right corner of each page is a "revision date". Initial printings will have the number "0" printed and the printing date. All subsequent revisions will have the revision number followed by the date of that revision. When such revisions are made, a "table of revisions" page will also be issued: This page (or pages) should be inserted in front of the opening page (this page) of each affected chapter. A new "table of revisions" page will accompany any revision made to a chapter.

Arrows

Most drawings will have arrows to show which direction the parts are facing, unless the drawing itself makes that very obvious. "A/C UP" refers to the direction that would be up if the part were installed in a plane sitting in the upright position. In most cases the part shown will be oriented in the same position as the part itself will be placed during that particular assembly step. However, time goes on and changes are made, so careful attention should be paid to the orientation arrows. That old cartoon of the guy agonizing over the plans for his canoe, built one end up, one end down, should not happen in real life. Especially to you.

CONTENTS

1. INTRODUCTION
2. DRAWING LIST
3. EQUIPMENT REQUIRED - SPECIAL PARTS, TOOLS & SUPPLIES
 - A. PARTS
 - B. TOOLS
 - C. MATERIALS & SUPPLIES
4. PROCEDURE
 - A. FIREWALL PREPARATION
 - B. MOTOR MOUNT ATTACHMENT
 - C. NOSE GEAR, FINAL INSTALLATION
 - D. NOSE GEAR BOOT
 - E. FUEL SYSTEM (FIREWALL FWD)
 - F. MOUNTING THE ENGINE
 - G. COWLING INSTALLATION (LOWER COWL)
 - H. COWLING INSTALLATION (UPPER COWL)
 - I. ENGINE BAFFLING
5. LYCOMING 0-320 AND IO-320 ENGINE BAFFLING INSTALLATION
 - A. ALUMINUM BAFFLE PLATES
 - B. SPARK PLUG WIRE GUIDES
 - C. RUBBERIZED SEALING STRIPS
 - D. SILICONE SEALING
 - E. OIL COOLER AIR LINE
 - F. MAGNETOS
 - G. REMOTE OIL COOLER MOUNTING
 - H. SPARK PLUG LEADS
 - I. EXHAUST SYSTEM
 - J. CABIN HEAT SYSTEM
 - K. AIR INTAKE SYSTEM (ENGINE)
 - L. PROPELLER INSTALLATION, CONSTANT SPEED
 - M. PROPELLER INSTALLATION, WOOD, FIXED PITCH
 - N. SPINNER
 - O. TACHOMETER

1. **INTRODUCTION**

The engine installation, when completed, may tend to look rather complicated but it is actually quite simple when taken one step at a time. The scope of this chapter does not include educating the builder on all the disciplines learned by an A&P mechanic, it is advised that you at least have one inspect and approve your installation prior to any flight attempts.

NOTE: The book: "Firewall Forward" by Tony Bingelis is available from the EAA in Oshkosh (1-800-843-3612), and is highly recommended for the non A&P builder. It would be most beneficial to read it cover to cover before proceeding with this chapter.

This chapter will cover the following systems/installations in the order listed: Firewall preparation, Fuel system, Nose Gear Boot, Cowling Installation, Engine Baffling Installation, Oil Cooler, Spark Plug Leads, Exhaust pipes, Cabin Heat System, Fuel Injector Control Cables, Fresh Air / Filter Air-Box / Valves, Propeller, Spinner, Magnetos, and Tachometer. Keep in mind that this is undoubtedly the world's tightest crossover exhaust system, and equally tightly cowled. The positioning and clearances of all items under the cowling must be thought through in an integrated manner, before any one item is positioned to avoid a domino effect of problems. Read this chapter start to finish, before starting the installation.



21-2

Chapter 21	REV.	0 / 11-1-91
ENGINE INSTALLATION - LYCOMING		

2. Drawing list

Figure	Page	Title
21-1	21-7	Firewall layout
21-2	21-8	Firewall grommet installation
21-3	21-9	Control cable layout
21-4	21-10	Motor mount installation
21-5	21-13	Nose gear boot
21-6	21-14	Pattern for nose gear boot construction
21-7	21-15	Nose gear boot construction
21-8	21-15	Boot cover plate
21-9	21-16	Nose gear boot installation
21-10	21-17	Firewall fuel connection
21-11	21-18	Gascolator installation
21-12	21-20	High pressure "fuel injection" boost pump installation
21-13	21-21	Engine driven fuel pump, plumbing
21-14	21-24	Dynafoal engine mount
21-15	21-25	Engine mounting biscuits
21-16	21-26	Cowling pre-fitting trim requirements
21-17	21-28	Cowl fitting
21-18	21-30	Trimming the air inlet flange on the lower cowling
21-19	21-31	Firewall flange build up
21-20	21-32	Cowling attachment screws
21-21	21-34	Engine baffling assembly
21-22	21-37	Center cylinder baffling
21-23	21-39	Securing lower edge of cylinder plates
21-24	21-40	Lycoming 320 baffling
21-25	21-41	Plug wire guides
21-26	21-46	Typical oil cooler installation, forming scat tube attachment
21-27	21-47	Baffling flex seal
21-28	21-50	Shroud, oil cooler
21-29	21-50	Baffling, flange - remote oil cooler
21-30	21-53	Cabin heat valve
21-31	21-57	Air box construction
21-32	21-58	L320 shroud configurations
21-33	21-59	Remote filter air box assembly
21-34	21-60	Typ. ram/filtered air install. for front-mounted fuel injection
21-35	21-61	Ram airbox, with both carb heat and filtered air
21-36	21-66	Propeller extension / prop / spinner assembly
21-37	21-68	Spinner cutout
21-38	21-70	Hartzell 2 blade spinner cut-out template
21-39	21-71	Hartzell 2 blade prop and spinner assembly
21-40	21-72	Mechanical tachometer location



3. Equipment required

A. Parts

Motor mount

AN-723A bolts (4)

AN365-720 nuts (4)

AN365-1032 bolts (4) for mounting gascolator

AN3-xxA nuts (4) for mounting gascolator

AN816-6D fitting for gascolator

AN822-6 fitting for gascolator

OPTIONAL PARTS:

Item Description	Source
Lycoming engine, NEW! - - - - -	N
Spinner & Backup Plate - - - - -	N
Prop, Hartzell & MT constant speed - - - - -	N
Prop Governor - - - - -	N, C
Cowl Scoop for fuel injected / Carbureted engines - - - - -	N
Tinnerman washers - - - - -	N, C
Baffling Kit, aluminum & flex seal - - - - -	N
Nose Gear boot - - - - -	N
Control Cable, Throttle (friction lock) - - - - -	N, C
Control Cable, Mixture (ratchet)- - - - -	N, C
Control Cable, Prop Gov. (vernier) - - - - -	N, C
Control Cable, Cabin Heat - - - - -	N, C
Control Cable, Air Selector (ratchet) - - - - -	N, C
Cabin Heat Valve - - - - -	N, C
Gascolator - - - - -	N, C
Fire Shield Tube covering- - - - -	N, C
Zip Ties, 2" dia. - - - - -	C
Scat Ducting, 1-1/2" dia. - - - - -	C
Scat Ducting, 3" dia. - - - - -	C
Hose Clamps, stainless, 4" dia. - - - - -	C
Hose Clamps, stainless, 2" dia. - - - - -	C
Oil Cooler, 9 vane - - - - -	C
Shroud-fiber glass, Oil Cooler - - - - -	U
Shroud-fiber glass, Air Filter - - - - -	U
Air Filter - - - - -	U, C
Electric boost pump - - - - -	N, C
Exhaust system - - - - -	N

C = Catalog Supplier, such as Aircraft Spruce & Specialty 1-800-824-1930

N = Neico, 1-503-923-2244

U = Owner fabricated



- B. Tools
Drill motor
Assorted drill bits:
 3/4"
 13/16"
 7/16"
 7/8"
 1 1/2"
Level
Assorted wrenches
Torque wrench
Cleco pliers and about 6 clecoes or equiv.



C. Materials and supplies

	QTY	
Assorted grommets:		
AN931-4-12, 1/4" I.D.	1	
AN931-9-13, 9/16" I.D.	1	
AN931-4-7m, 1/4" I.D.	1	
AN931-4-7, 1/4" I.D.	2	
Fiberfrax scraps		
Stainless stl scraps from firewall		
High temp silicone		
Sheet metal screws	6	(for mounting nose gear boot)
Hose clamp for nose gear boot		
Solid and flexible fuel line and fittings to match your particular fuel system		
(See figure 21-12 for typical installations)		
#20 gauge wire for wiring magnetos, with appropriate connectors.		
Assorted grit sandpapers		
Micro		
Safety wire		
BID material		



21-6

Chapter 21	REV.	0 / 11-1-91
ENGINE INSTALLATION - LYCOMING		

4. Procedure

A. Firewall preparation

These procedures, which have been covered in previous chapters, will need to be completed before proceeding with this chapter; refer to chapter 11, page 11, for the installation of the firewall flange. Refer to chapter 5, page 5-36, for the installation of the Fiberfrax / Stainless Steel Firewall (be sure to save the firewall leftovers, they are used in this chapter for shielding). Refer to chapter 5 for the installation of the Motor Mount and Nose Gear.

Before mounting the engine, it is best to first locate and drill the access holes for cables, wires, etc. Mark the location of the holes and items (gascolator, volt reg., etc.) You may find it helpful to temporarily install the Motor Mount and tape the firewall items in place to work out the best placement that is free of interference.

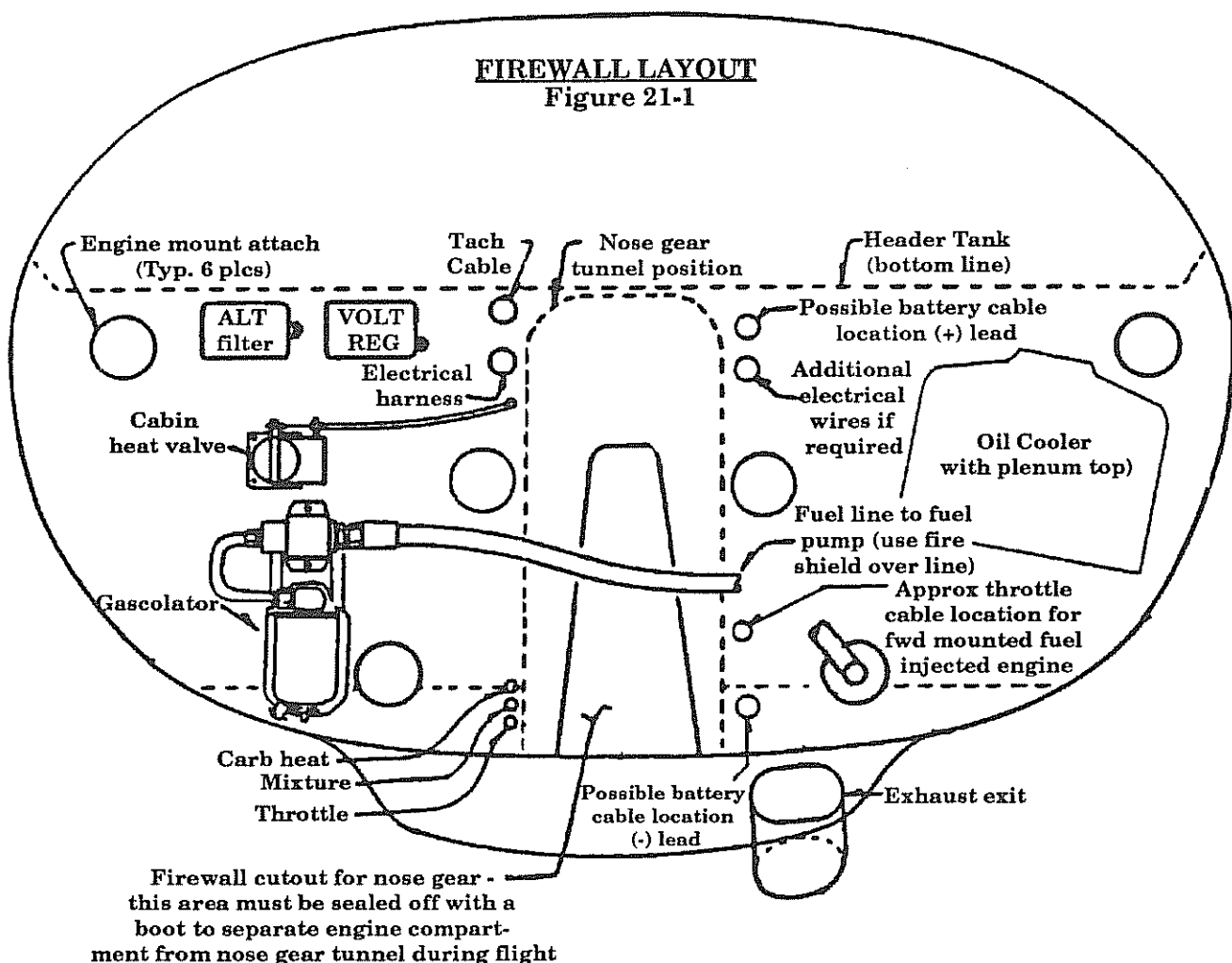

1. Per figure 21-1 locate all through holes. There are many ways to route items through the fire wall, this is simply one possible approach that does work. All through holes must be sealed and you must also protect the cables and wires from chafing etc. A rubber grommet will usually work well, it can be installed in two different manners, see figure 21-2. A small dab of high temperature silicone will secure the grommets in position.
2. The recommended hole diameters are as follows:

ITEM	Hole Dia.	Grommet size
Tach Cable (mech)	3/4"	AN931-4-12, 1/4" I.D.
Electrical Harness	13/16"	AN931-9-13, 9/16" I.D.
Throttle Cable	7/16"	AN931-4-7m, 1/4" I.D.
Carb Heat Cable	7/16"	AN931-4-7, 1/4" I.D.
Cabin Heat Cable	7/16"	AN931-4-7, 1/4" I.D.
Gascolator	7/8"	NONE
Cabin Heat Valve	1-1/2"	NONE (Optional from Neico)
3. You will need a very sharp drill to get through the stainless steel on the firewall. For the larger holes, it is sometimes best to use a carbide cutter in a rotary tool to get through the stainless then drill on through with a standard drill bit.
4. The cabin heat valve may be installed on either the left or right side of the firewall.

FIREWALL GROMMET INSTALLATION

Figure 21-2

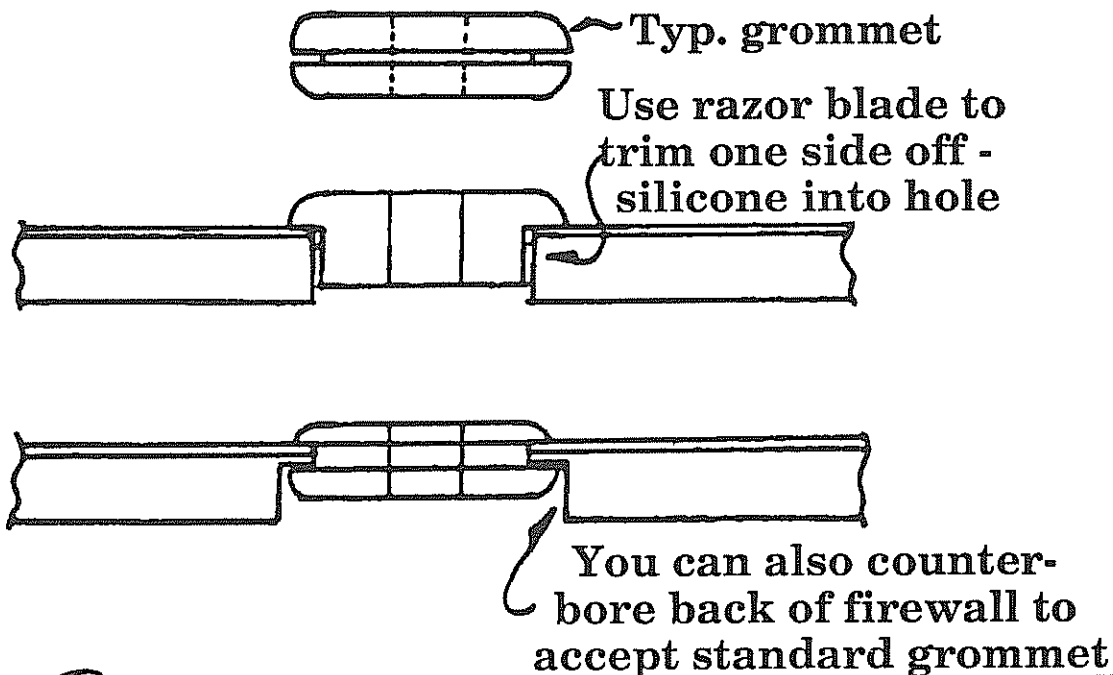

CONTROL CABLE LAYOUT

Figure 21-3

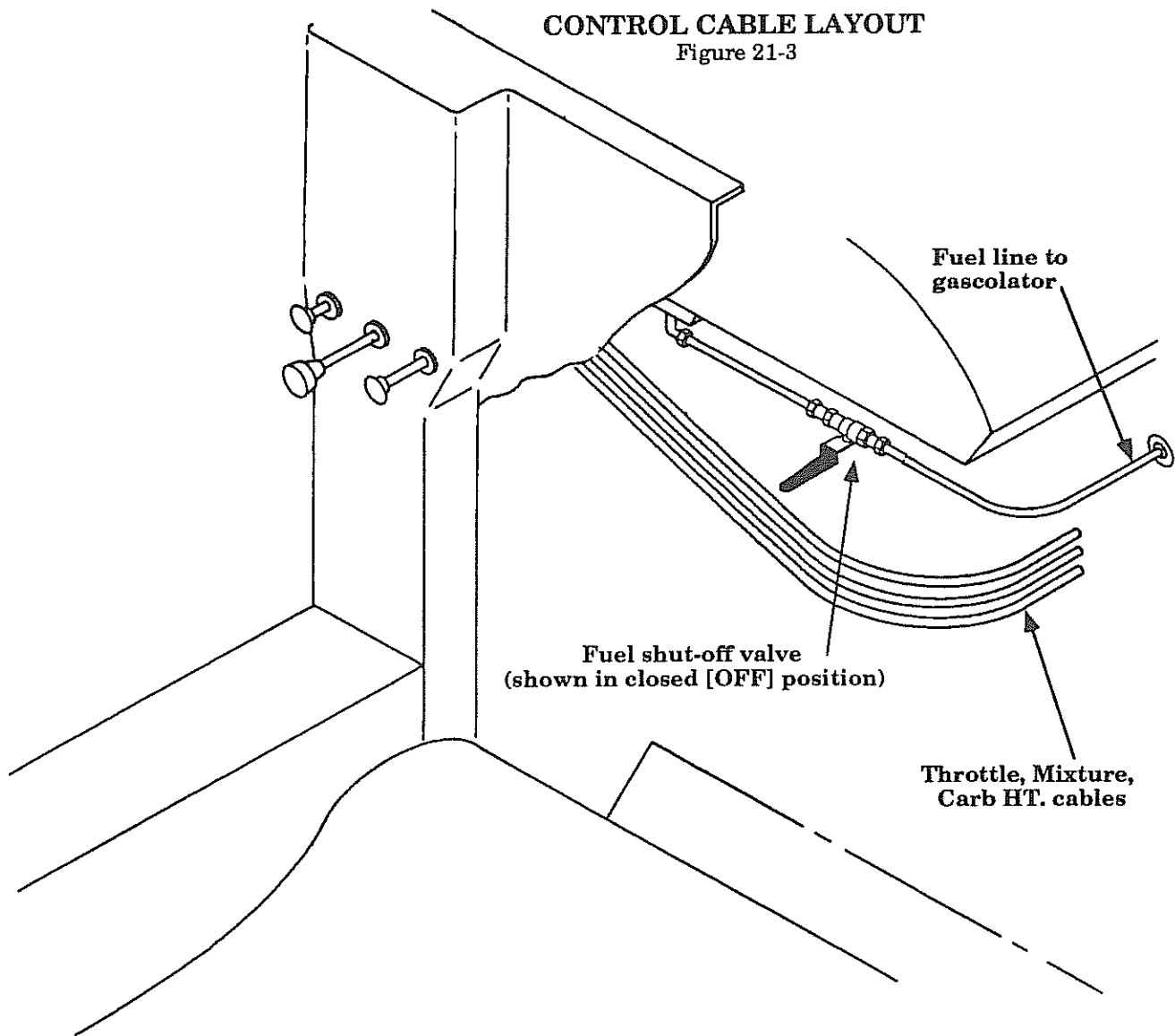

Fuel line to gascolator

Fuel shut-off valve
(shown in closed [OFF] position)

Throttle, Mixture,
Carb HT. cables

B. Motor mount attachment

1. Be sure the fuselage is level, check the level of the top left and right hole marks (ignore the center one for now). If they are not level with each other, cover old line with tape so as not to get confused. Be sure to leave the hole mark exposed, use a level as a straight edge and pivot on the lower of the two hole marks. Move the opposite end up or down to establish level and mark a new level line across the firewall, see figure 21-4. The markings on the firewall should however be correct. In actuality, $\pm 1/8"$ is perfectly acceptable.

MOTOR MOUNT INSTALLATION

Figure 21-4

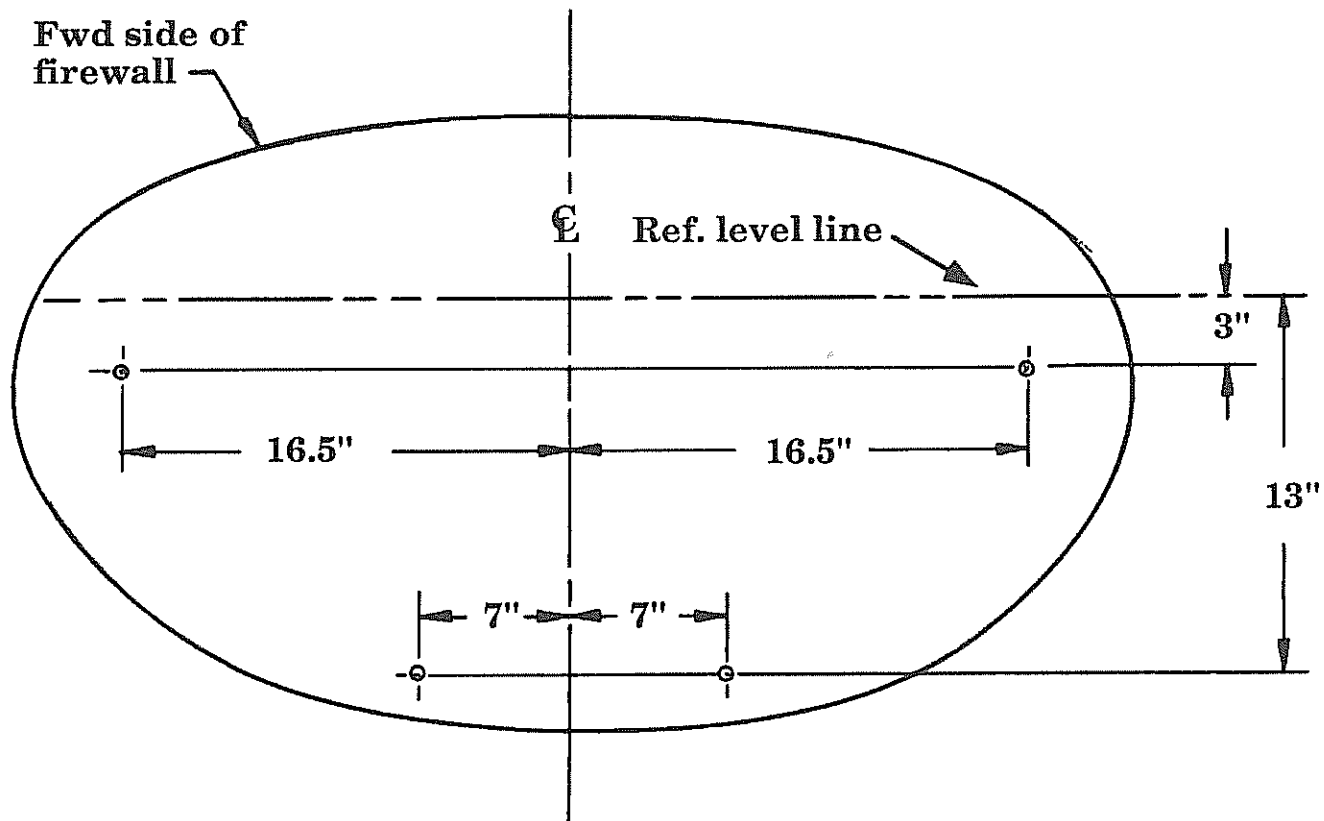

2. Using a 7/16" bit, drill through the firewall for the first attach bolt and bolt the mount to the firewall using one AN-723A/AN365-720 bolt/nut, loose enough to swing it up or down. Now align the center of the opposite side of the motor mount hole with the level line. Holding the motor mount firmly in place, use a 7/16" Dia. transfer punch or use the motor mount as a drill guide and drill through the firewall. (The nylock nuts must be on the aft side of the fslg).

3. Bolt through this hole in the same manner as the first. Tighten both bolts, Now the remaining mount holes can be drilled and bolted in position. We have demonstrated that bolting through the fiberfrax will work satisfactorily, however some builders have chosen to remove the fiberfrax directly under the mounting pads and add AN970-7 area washers. This will have the added appeal of a nice smooth stainless steel face sheet whereas bolting through the fiberfrax will tend to depress the stainless steel just a little. Thus, if so desired, use two washers in place of the fiberfrax under the stainless steel face sheet.



C. Nose gear, final installation

1. If you have not already installed / aligned the Nose Gear per chapter 5, then that must be done at this point.
2. Having completed the Nose Gear alignment and installation, perform the final cotter pinning / safety wiring / etc., as required.
3. If you have not ground tested your landing gear / hydraulic system per chapter 14, do it now before you get the motor in the way of easy access.
4. Be sure that all the wheels are securely blocked when proceeding on this installation.



21-12

Chapter 21 REV. 0 / 11-1-91
ENGINE INSTALLATION - LYCOMING



D. Nose gear boot

The nose gear cut out in the firewall will require a boot to seal the nose gear tunnel from the engine compartment. This close out boot should be made of stainless steel and lined on the aft side with a fireproof insulation such as fiberfrax or an equivalent.

1. Neico offers a stainless steel boot as an option, see figure 21-5, or fabricate one per figures 21-6 and 21-7. Use fiberfrax scraps from the firewall to line the inside of the boot, adhere it to the boot with high temp silicone.

NOSE GEAR BOOT

Figure 21-5

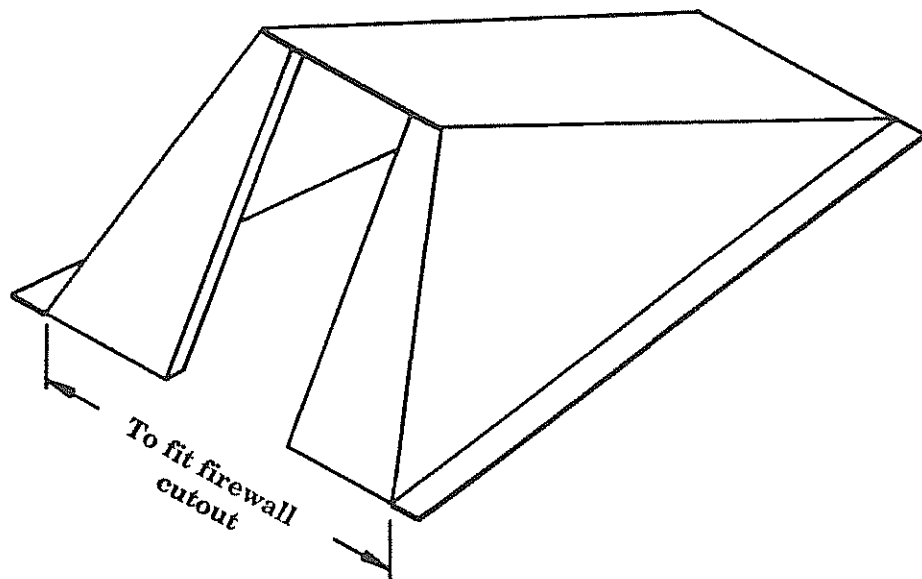

2. The boot should be mounted so that when the nose gear is fully retracted, the strut will fit relatively snug up to the top of the opening, see figure 21-8, however note that the boot also butts to the bottom of the firewall which is of first importance since the upper snug fit can be achieved with a secondary piece of stainless attached with pop rivets.

Mount the boot to the firewall with sheet metal screws, 3 per side. Use scrap firewall stainless steel and flexible high temp baffling material to make a boot seal that fits the contour of the top of the strut, attach this to the boot with sheet metal screws or pop rivets, see figure 21-8.

3. With the nose gear fully retracted, the open slot below the strut must be sealed as well. Again use scrap firewall stainless steel or .040" aluminum sheet and flexible baffling material to make a boot cover plate which clamps directly to the strut and fills the open slot in the boot when the gear is retracted, thus the entire nose wheel well area is fully sealed off, see figure 21-9.

NOSE GEAR BOOT CONSTRUCTION

Figure 21-7

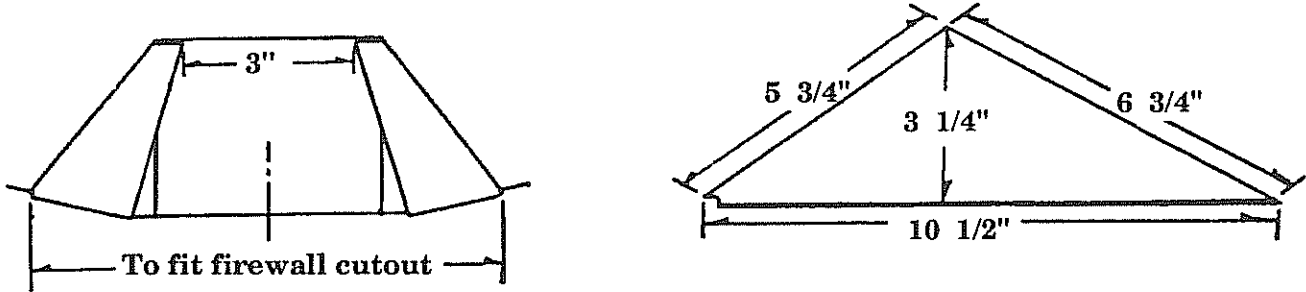

BOOT COVER PLATE

Figure 21-8

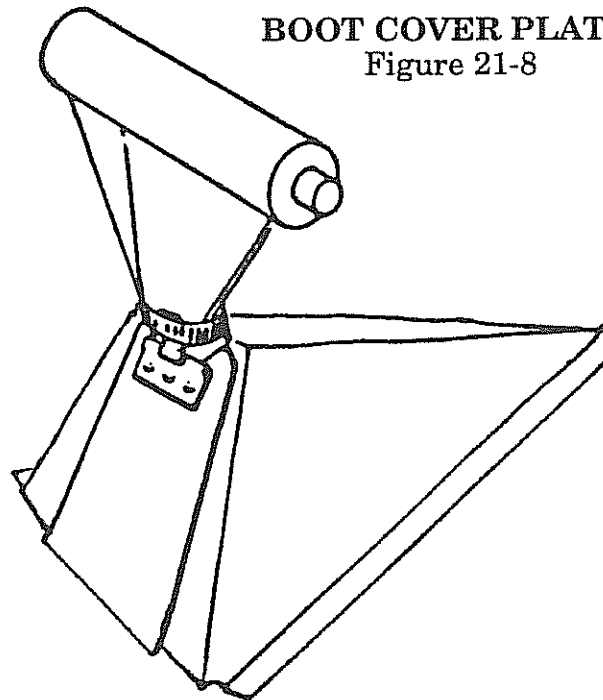

NOSE GEAR BOOT INSTALLATION

SIDE VIEW

Figure 21-9

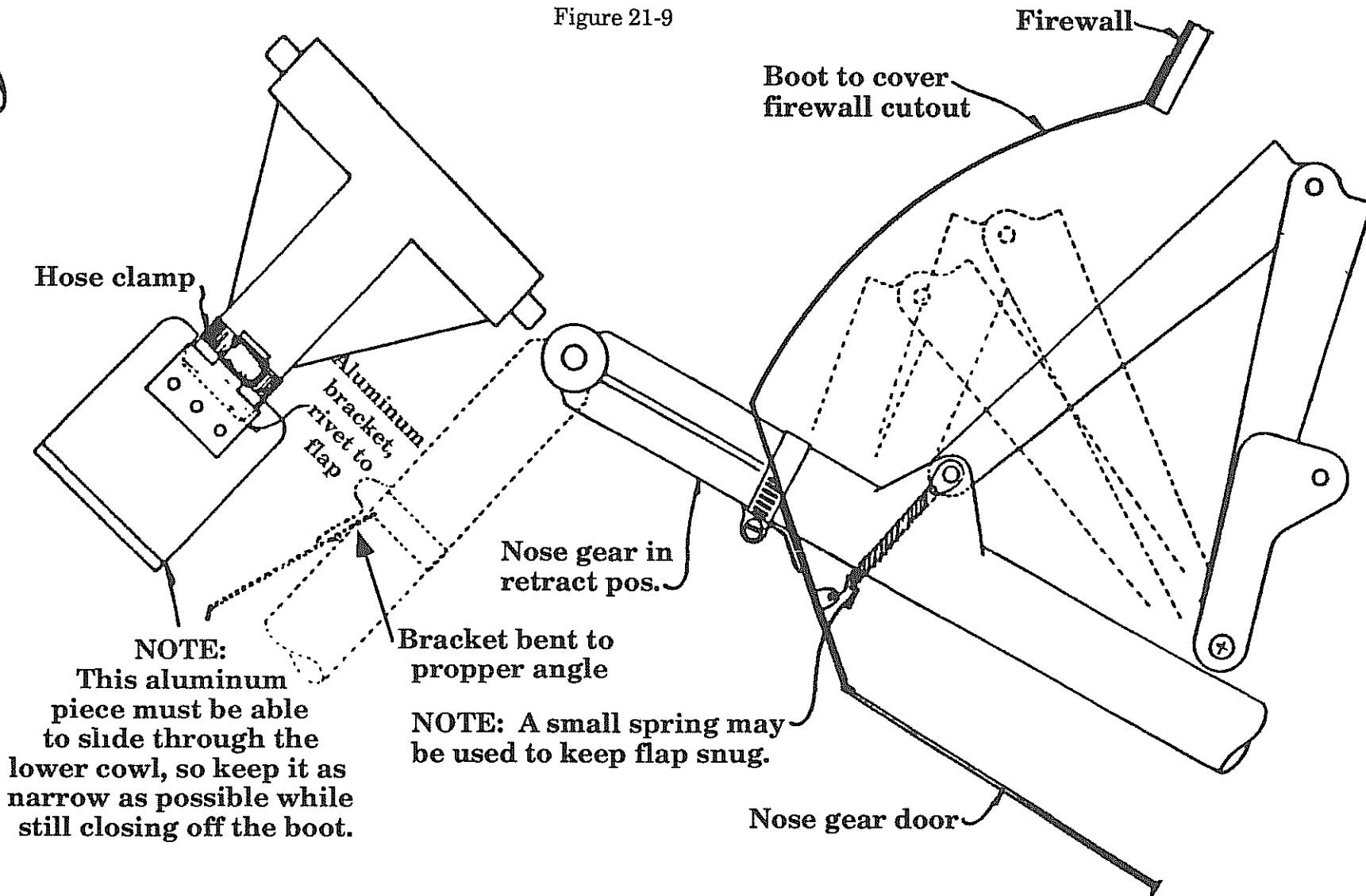

NOTE:
This aluminum piece must be able to slide through the lower cowl, so keep it as narrow as possible while still closing off the boot.

NOTE: A small spring may be used to keep flap snug.

E. Fuel system (firewall fwd)

The fuel system is obviously critical to safe operations and thus the cause of a high percentage of accidents. Read the entire chapter before starting to work. Proceed slowly, with great care and attention to the smallest details.

Gravity feed, although technically possible with very low power settings, is NOT recommended since "head" pressures are at minimums and therefore the slightest disturbances can reduce flow to less than acceptable rates. An engine driven fuel pump is required with an electric boost pump as a backup.

The "Fuel System - Firewall AFT" was previously covered in chapter 11. As a rule of thumb, all fuel lines from the header tank fwd must be 3/8" aluminum line or -6 flex line. (The exception is with the fuel injected engines that use a dash-4 line from the engine driven pump to the injector and from the injector up to the divider head.) Smaller lines could deliver adequate amounts of fuel but the larger line reduces the tendency of clogs. The fuel line from the header tank line will pass through the shut off valve just down stream from the header tank line exit, then run fwd along the bottom of the header tank to the firewall, where the line turns 90° to run down the aft side of the firewall to connect to the gascolator fitting that protrudes through the firewall from the fwd side. Refer to figure 21-10.

Firewall fuel connection

Figure 21-10

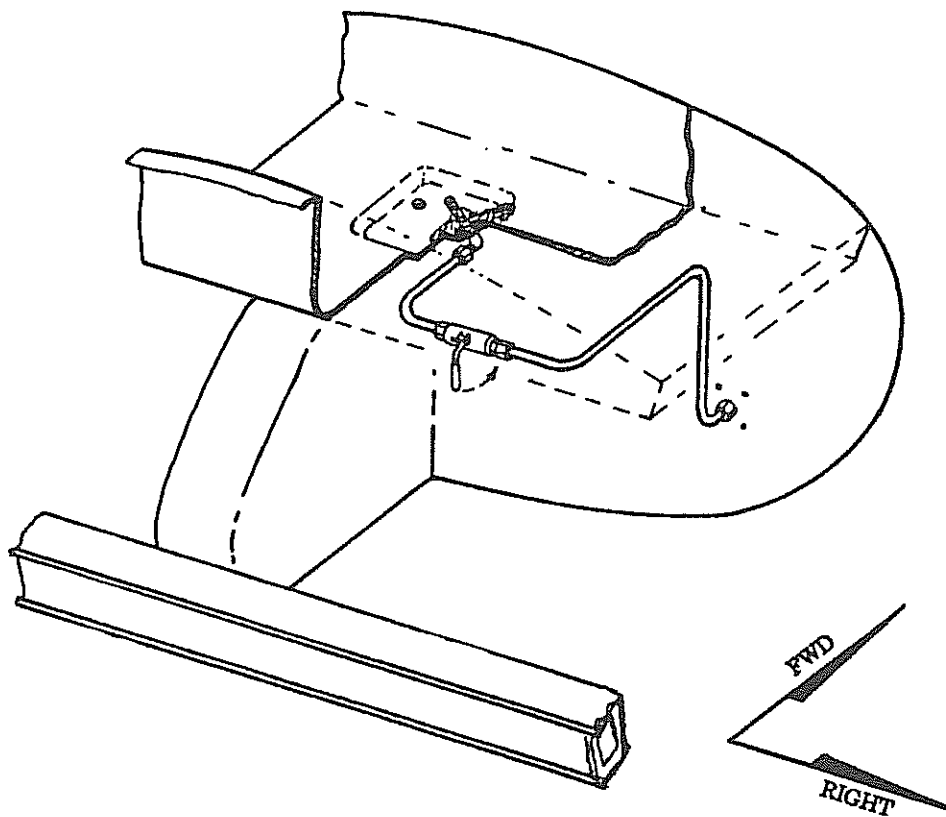

Gascolator Installation

Figure 21-11

SIDE VIEW

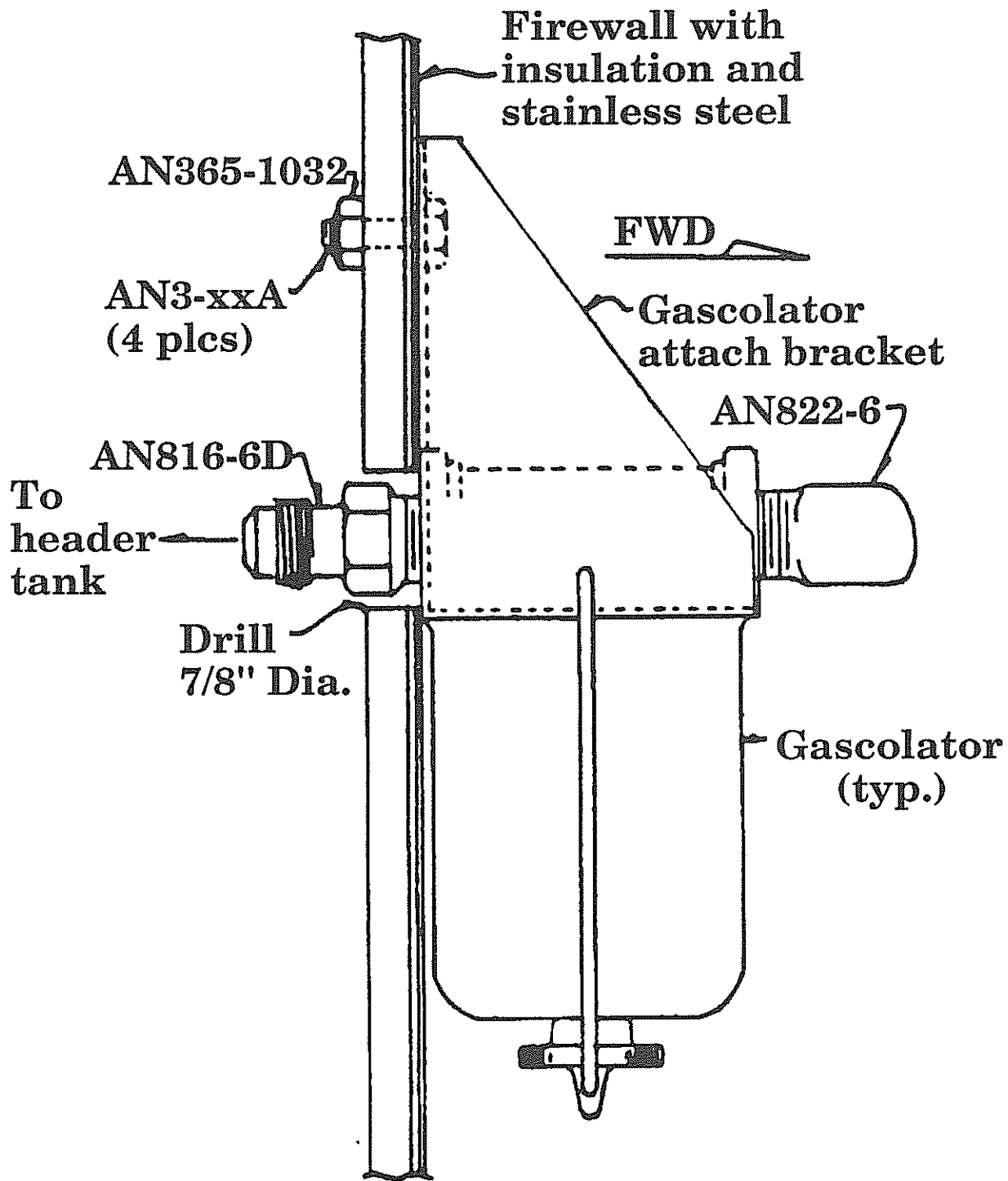

1. The gascolator (figure 21-11) is a final separator of contaminants before the fuel enters the carburetor (actually there is a last screen at the carb or injector body). The gascolator could be positioned slightly inboard of the location shown (see figure 21-1), between the lower engine mount attach point and the nose gear tunnel. This however crowds the throttle and mixture cables (if you have a carbureted engine) so the shown position is preferred. Access to the gascolator drain will be required. Either drill a small hole through the cowl at the appropriate location to insert a test tube sampler or (at the inbd location) angle the quick drain such that it can be reached from just aft of the lower cowl scoop from below (realize that this will require you to lay on your back and watch the spilled fuel run down your arm). If you have a gascolator with a remote cable operated drain (common in some Cessnas) be sure to position a drain line such that it drains well outside of the cowl, not into the cowl. Use a small aluminum line to run from the gascolator bowl to the cowl exit (approx. 3/16" dia. aluminum line depending on the exact type of gascolator selected. The *typical* end fitting required is the AN818-3D nut with AN819-3D sleeve and 3/16" 5052-0 aluminum tube).
2. Attach the gascolator with four (4) AN3 bolts to hold the support bracket. Use fire shield around the fuel lines everywhere inside the cowling. See figure 21-12.
3. An electric boost pump must be installed for the fuel system. This boost pump should have an operating pressure of 21 psi (for injected engines) or 4-6 psi (for carbureted engines). 1/4" pipe ports (dash 6 aluminum line) are standard for the low pressure boost pumps that Neico stocks. The boost pumps must also be free flow in nature (which means fuel must flow through them without turning them on). These pumps have an inlet and outlet port which can NOT be interchanged, be sure that you are plumbed correctly regarding the direction of flow. Locate the pump on the firewall, just inboard of the gascolator, see figure 21-12.

NOTE: There are a great many high pressure boost pumps found on the used market for fuel injected engines that are NOT suitable for use in the Lancair. Be sure about what you are considering purchasing. (Neico has consequently begun stocking the correct factory new units for our fuel injected engines.) Neico also stocks the 4-6 psi pump.

4. Per figure 12-1, use 3/8" aluminum line to connect the gascolator outlet port to the Boost Pump inlet port. Be sure that the radius is smooth and the line is not kinked.
5. From the outlet side of the boost pump, a flexible line will connect to the engine driven fuel pump. On new pump installations, it may be necessary to adapt the pump threads to the AN type fittings by use of special pump fittings. The Aircraft Spruce catalog lists this part as No. 6470069 (two required). Remember to use only steel AN fittings on the fuel pump since it is attached to a vibrating hunk of iron - the engine.



HIGH PRESSURE "FUEL INJECTION" BOOST PUMP INSTALLATION

Figure 21-12

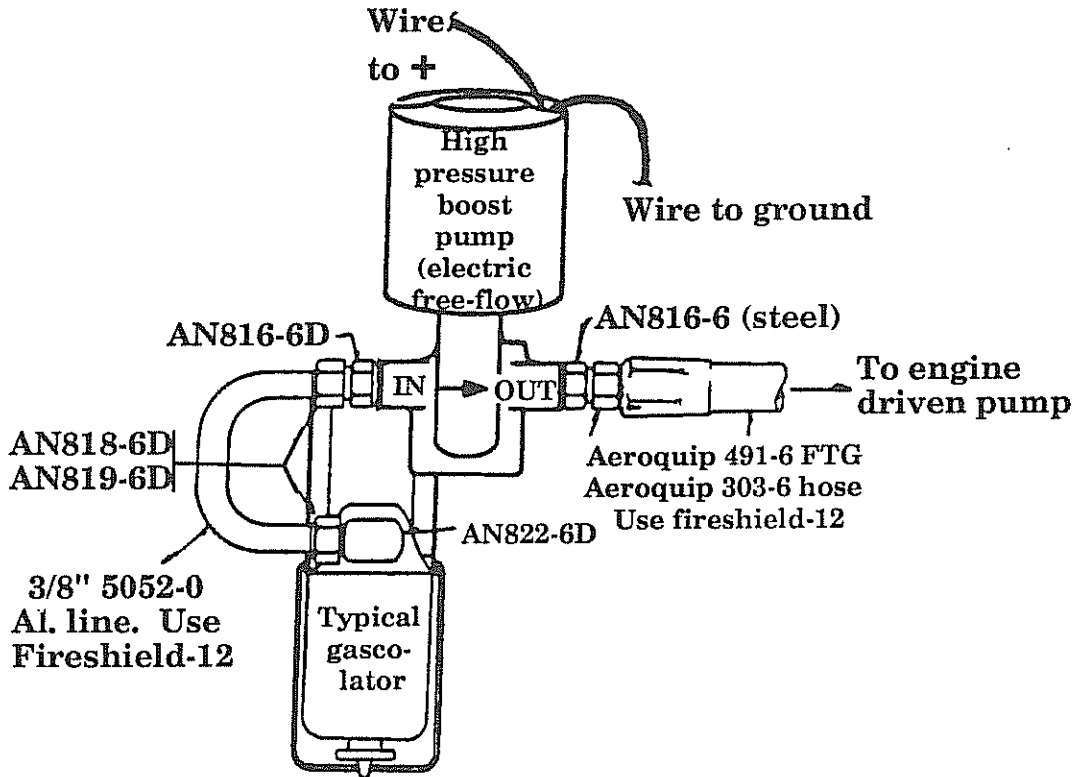

LOW PRESSURE BOOST PUMP INSTALLATION

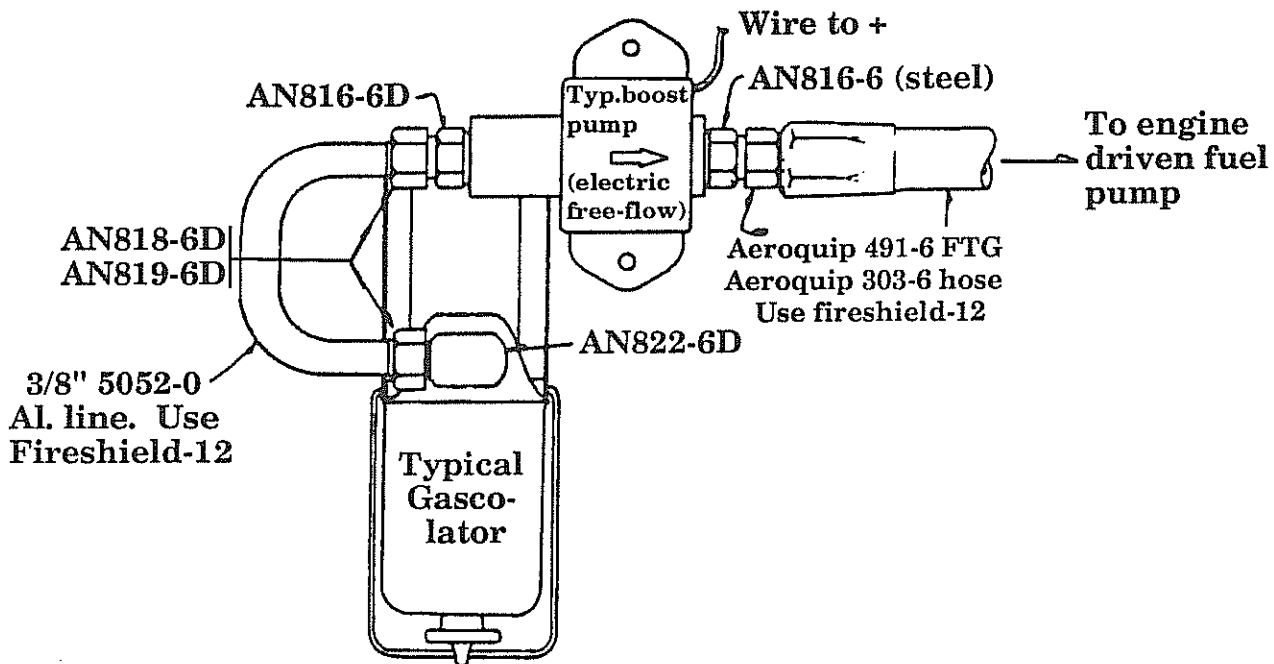

6. Generally, a straight AN816-6 works well on the upstream side of the engine driven fuel pump and a 90° AN822-6 on the down stream side going to the fuel injector or carburetor.

The fuel injector works best with a 45° fitting (AN823-6) to accept the fuel line, carbureted engines use a 90° fitting. The flex fuel line routes aft and up from either the injector or carburetor such as to clear the engine mount and also clear, with as much room as possible, the exhaust pipes. Be sure that there is sufficient clearance from the engine mount so that no binding stresses will be applied to the line. Again, cover these with fire shield.

WARNING: DO NOT use aluminum fittings where flexible fuel line is to be used between fixed position items and the engine (which moves). These aluminum fittings have been known to fatigue and crack with time.

7. Use Aeroquip 303-6 flexible hose with AN491-6 fittings for fuel lines from the boost pump. Use fire sleeve -12 with this hose.

Engine driven fuel pump, plumbing

Figure 21-13

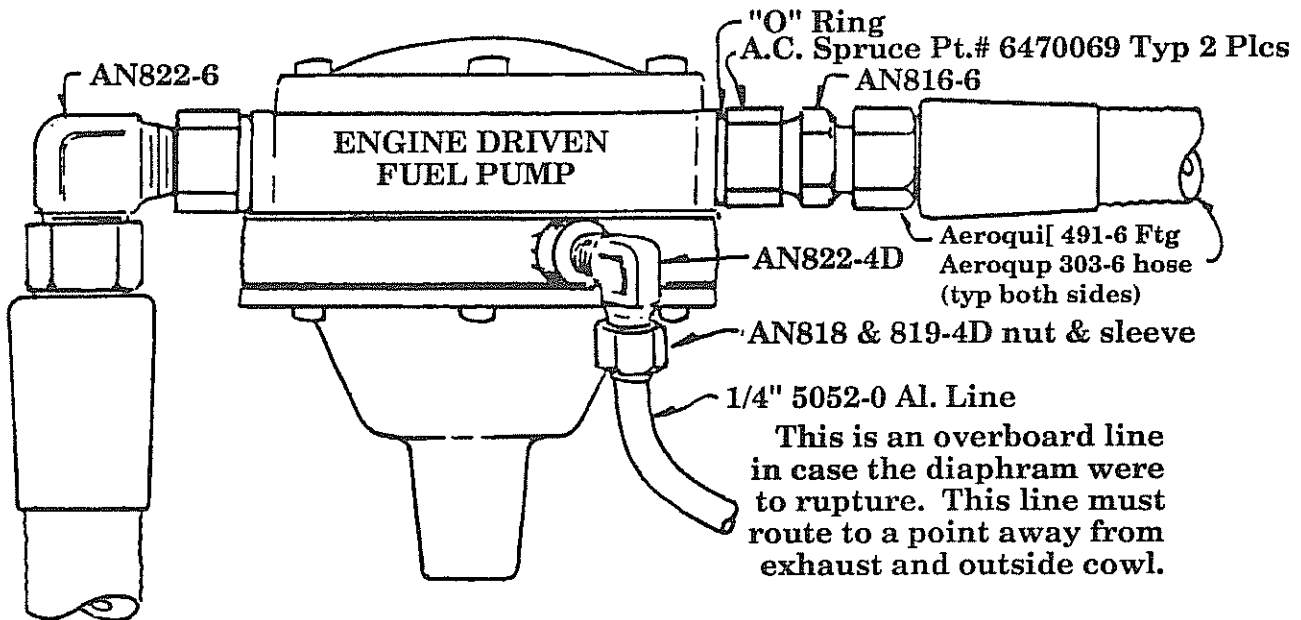

WARNING: The fuel system should be kept as cool as possible to prevent vapor formation and the resultant potential of vapor lock. Particularly true with auto fuels due to their less desirable reed vapor pressure.

8. Adding a fresh air blast tube such that it blasts onto the gascolator and the boost pump is a good idea. A better addition is to build a simple sheet metal shroud around these items to help direct the cool blast air. A 1/4" aluminum blast tube line is sufficient, it can be plumbed from the upper pressure cowl attaching to the rear baffles.

NOTE: It is also recommended that you place some sort of temperature monitor within the engine compartment to check various locations. Temperatures from 100° F to 130° F are common and generally acceptable. Temperatures generally should not exceed 150° F in the rear central accessory area of the cowl. A blast tube to cool the fuel system is still strongly recommended.

9. When the fuel lines are completed, check to make sure that all lines are tight.
10. When you are ready to add fuel, level the plane which will require some blocks under the main gear. This is to approximate a flight attitude.
11. Add one gallon of fuel at a time while in this levelled position and mark the relative position of fuel as it begins to appear on the gauge. Increase the fuel at one gallon increments and note this on your gauge (either sight tube type or mechanical type). Your header tank gauge should provide an indication of fuel amount (i.e., 11 gal.) along with markings for full, half, quarter, and empty. This will provide an accurate measure of fuel in the header tank, but ONLY during cruise flight.

WARNING: Remember that during nose up conditions, fuel can appear to be more than is actually present and during nose down conditions, fuel can appear to be less than is present. Fuel levels will indicate accurately only during level flight. This is particularly evident with the sight tube type of gauge.

NOTE: It is important that the engine be run for at least one hour on the ground prior to any flight attempts. After this ground run, it is also recommended that the fuel line be disconnected on the up stream side of the engine driven fuel pump and a gravity flow check be made. This will provide an indicator of any blockages that may exist in the system from dirt and contamination accumulated during the building phase. You should have no difficulty flowing 15 gph with a nearly full header tank in a level condition, if you cannot, then look for a partial blockage somewhere.



F. Mounting the engine

The engine can be hung on the motor mount using an automotive engine hoist (you can rent these). Bolt up the engine with the rubbers and hardware that is appropriate to your mount style (Dynafoal or Conical). For engines with conical mounts, Lycoming lists a crush dimension as a means of setting the proper load on the mount pads.

For mounts with solid inserts (Continental 0-200 and Lycoming dynafocal) the bolt torque can be used. The following is a chart of approved bolt torques as listed by Continental:

BOLT THREAD SIZE	TORQUE (inch/pounds)
8-32 - - - -	22-30
10-32 - - - -	36-50
1/4-20 - - - -	75-85
1/4-28 - - - -	90-110
5/16-18 - - - -	155-175
5/16-24 - - - -	180-220
3/8-16 - - - -	220-260
3/8-24 - - - -	220-260
7/16-20 - - - -	400-450
1/2-20 - - - -	550-600

Engine incidence:

1. When mounting the engine, it is most important to check the crankshaft level condition of the engine on the airframe. To check this, level the airframe and check the level condition of the engine. This can be accomplished roughly by laying a level across the top of the valve covers but more accuracy is achieved by setting a level against the vertical flange of the crankshaft (where the prop will later attach). A small protractor type level works well here.
2. If necessary, shim the engine to achieve a level attitude. This can be accomplished using AN970-7 washers under the engine mount pads (between it and the firewall). Essentially, what ever thickness is placed under the bottom two must be reduced by a factor of 1/2 and placed under the middle two attach points. (I.e., if two are used under the bottom two pads, use one under the mid pads.)

Also, you can shim between the engine and the dynafocal mounting pads by inserting the same AN-970-7 washers. This location will have a little greater effect than the same thickness washers placed under the mount/firewall location.

This engine attitude, while not critical to safe and effective flight operations, is desirable since a nose down engine will result in less prop clearance and an increase in drag. We have flown with incidences of from +1° to -1° and the differences are nearly undetectable in flight operations however prop ground clearance is noticeably affected.

Engine offset

3. The standard offset is 1-1/2°s to the right. Here again, it does not appear to be critical and certainly less important than the incidence in a practical manner. We have never bothered to make any adjustments, we know of no one who ever has, so if you're close to square with the firewall in the first place, consider it done.

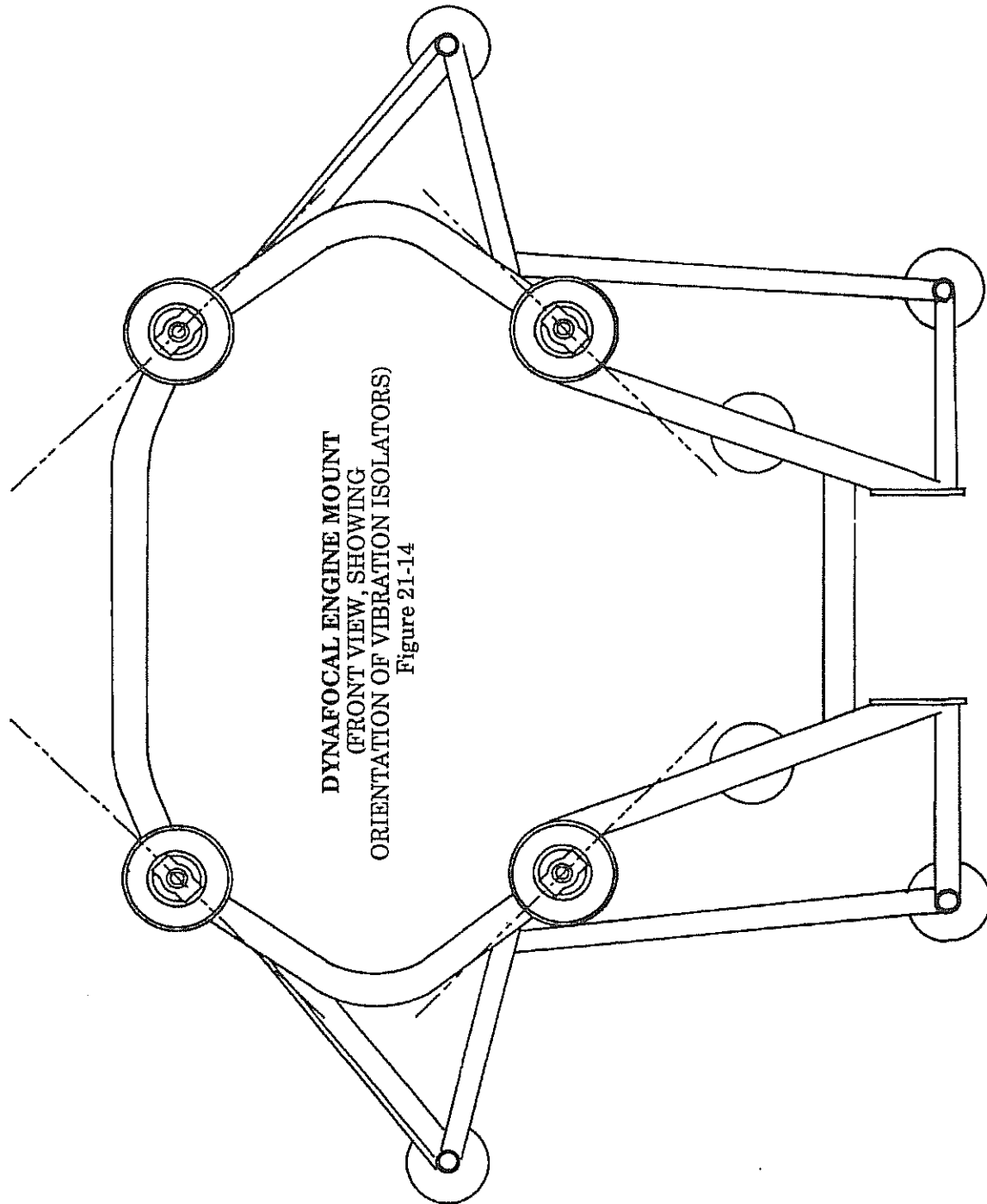

NOTE: To select the proper Lancair engine vibration isolators:

- 235 engines, fixed pitch prop, use 94150-40
- 290 engines, fixed pitch prop, use 94150-01
- 320 engines, fixed pitch prop, use 94150-01
- 320 engines, constant speed prop, use 94150-41

Engine mounting biscuits

Figure 12-15

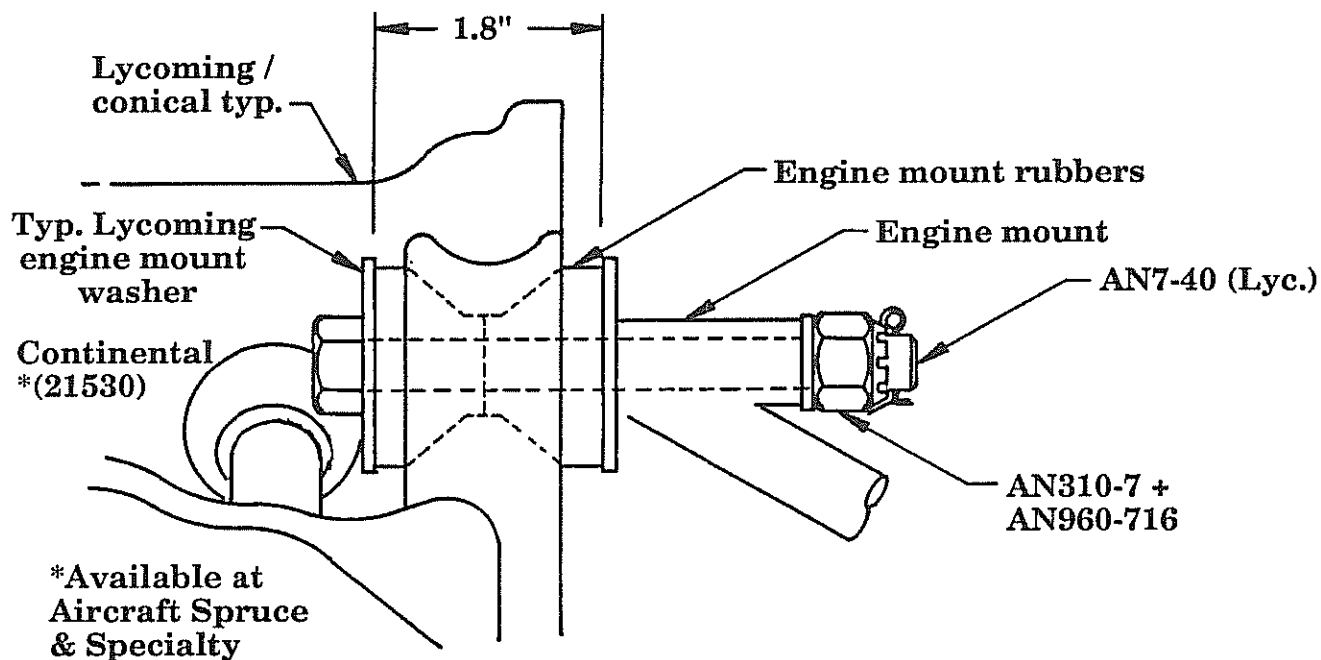

Dynafoal Mount

For attach bolt use AN7-34

94150-40
4 places

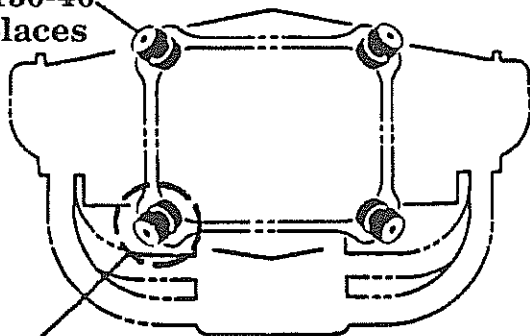

See exploded view for parts breakdown

AFT VIEW

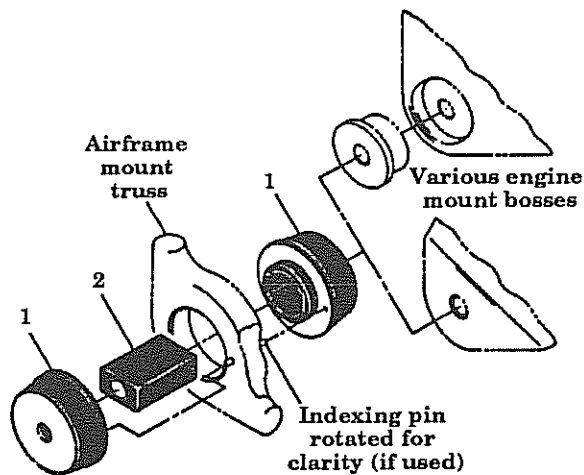

G. Cowling installation

This installation will benefit from the help of one or two other people to hold the cowling in place at each side and at the spinner; nothing heavy, just a steady hand. It can be done using clamps/tape/clecoes/etc., but it will be very frustrating and time consuming, at best. Before you start, the engine must be mounted with the proper pads, bolts, torque setting, etc. Plus you'll need to have the 4" prop extension attached (for the fixed pitch prop installation) or have the constant speed prop temporarily positioned and have the spinner backup plate attached. All of this is necessary to properly align the front of the cowling to the spinner.

The lower cowl scoop will have to be removed and modified if you're installing a fuel injection system (either fwd mounted injector or updraft injector) or a carbureted 180 h.p. Lycoming, the modified scoops are available from Neico as an option. It is best to install the cowl to the fuselage first to easily hold the cowl shape then remove the existing scoop and attach the replacement scoop.

NOTE: The engine will sag under the effects of heat and pressure on the rubber mount pads. Usually a vertical drop of 1/8" to 1/4" as measured at the spinner backup plate, is common. The cowl should therefore be fit to a position, about 1/8" - 1/4" lower, to allow for this sag. It is always difficult to hit this "sag variable" right on the money so if you are particular about the spinner to cowl alignment, plan on making some adjustments after the first twenty hours of flight. This can be done in a manner similar to that described for shimming and setting the incidence of the engine.

Cowling pre-fitting trim requirements

Figure 21-16

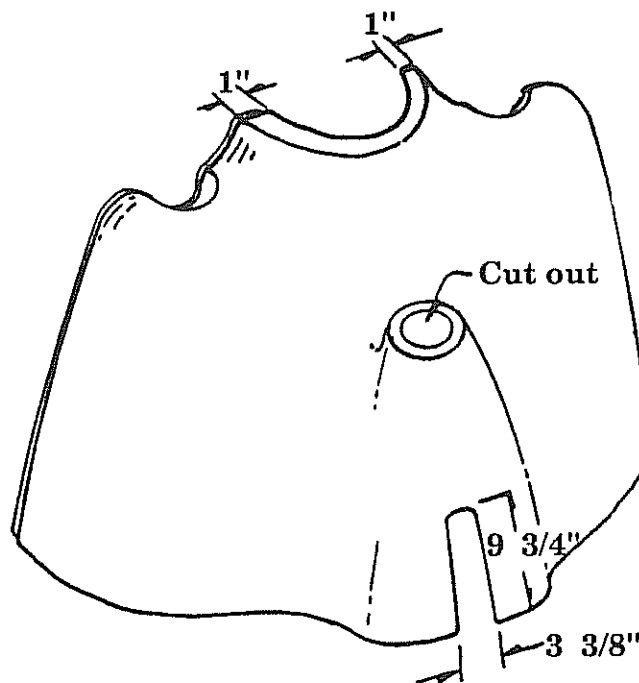

Cowl spinner flange:

1. Begin fitting with the lower cowl by first cutting away some of the forward vertical portion that is behind the spinner. Do not trim all of that vertical face away, leave a 1" flange all around (this can be done to the upper cowl as well). This flange is a structural necessity so don't cut it all off. See Figure 21-16.

Nose gear slot:

2. This is where the nose gear will swing forward to the locked down position, thus a slot is cut in the bottom aft edge of the cowling to allow for the nose gear travel. Measure and mark a fore to aft center line on the lower aft section of the cowl "scoop". The slot should be approximately 3-3/8" wide by 9-3/4" long.
3. Cut out the air inlet to the scoop (and the cooling air inlets, if not already opened). While you're at the two upper air inlet scoops, note the joggle on the lower cowl that will accept the upper cowl. Around the forward most radius of the cowl front, where the circular inlets are, sand down the joggle so that it becomes a bit deeper there. There is enough curvature that a very thin joggle is perfectly acceptable and will help "nest" the upper cowl which often tends to get a little too thick in those tightly radiused areas. Also remove any amount of the joggle that would "back lock" the upper cowl. By sanding in a vertical plane against these joggles (inside the circular inlets), you can reduce the tendency to back lock on the upper cowl. Once again, this will thin down that joggle through there but that's o.k. These joggles inside the circular inlets will typically be only about 3/8" high.
4. Now position the lower cowl up around the engine and temporarily attach with clamps to the firewall joggle at the upper corners, see figure 21-17.
5. Align the lower cowl to the spinner backup plate, remember to set the cowling about 1/8" - 1/4" lower than the bottom edge of the spinner. And allow for clearance between the cowl and the spinner of about 1/4", see figure 21-17.

An easy way to hold the front side of the lower cowl to the spinner backup plate is to cut two small wood spacers that set the proper dimension and clamp them between the backup plate and the face of the cowl. Use vice-grips to hold them since they can be set quickly and easily adjusted in small increments quickly as well (And you can do all that with one hand!). You'll probably note that the cowl, along the sides, tends to sag outward a bit. This should be kept in mind since when you are setting the top onto it and establishing the attach point on the firewall joggle, a little pulling at the firewall joggle locations can help bring that line back into its proper position.



Cowl fitting
Figure 21-17

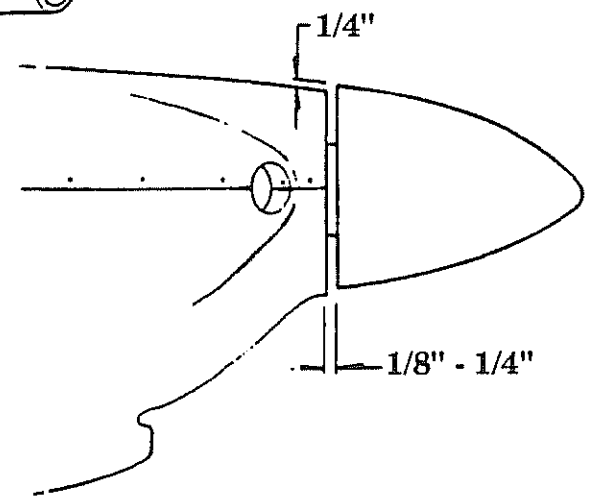
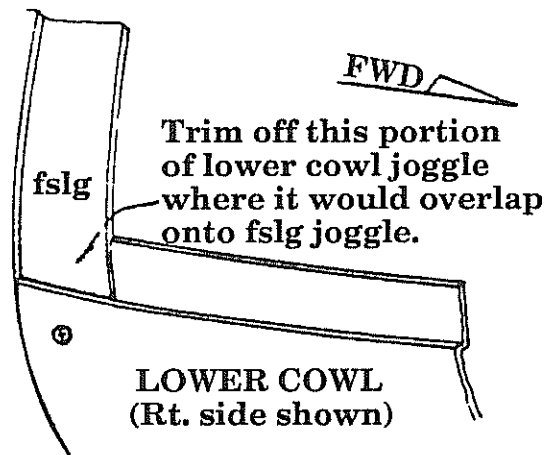
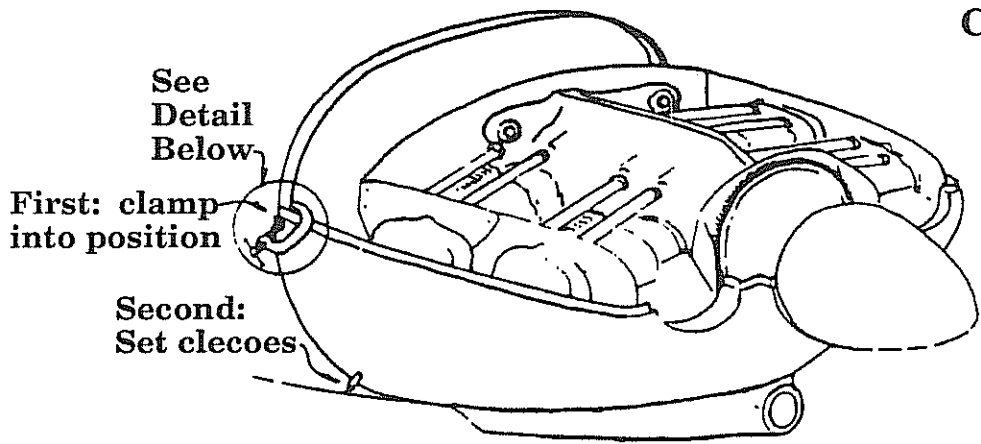

- Now temporarily attach the cowl with just one cleco about 1-1/2" below the joggle on the sides near each upper corner location, don't put the clecoes on the joggle since that is not only going to be trimmed off later, it will get in the way when you're fitting the upper cowl, see figure 21-17.

Place one cleco on the bottom, to one side of the scoop (the location of this cleco is not important but place it where the hole can be used for a final fastener later), see figure 21-17.



Trimming the excess cowl at the firewall:

7. Due to a number of variables, your cowls may be either too long, just right, or too short. If they are too long, the task is obvious and quite simple, just trim them shorter.

(If your cowl is too short)-

If the cowls are too short, the task is a bit more involved but not hard at all:

8. Assuming that you have at least some firewall joggle to get a hold of for cowling position, place a plastic tape release film along the inner cowl surface near the firewall joggle end.
9. With the cowl in position, lay a 3 BID tape onto the existing joggle and add just enough as required thus extending onto the cowl which has the plastic release tape on it. You are thus extending the joggle fwd the required distance to provide an overlap of at least 3/4". Allow this 3 BID flange to cure before removing the cowl.
10. The cowl / fslg juncture line will always require a little micro to fair them together nicely and if your cowl is too short, you'll simply extend this micro fairing fwd slightly.
11. Once the lower cowl is trimmed and fitted with an adequate flange along the firewall, then clecoes should be evenly placed about every 4" along the fslg flange, 1/2" fwd of the aft edge of the lower cowl. This will be the final location of the attachment screws, so a good looking layout is important.

Tip on locating the aft trim line for the cowls:

12. The trim line may seem difficult to establish since the cowl may be laying over the joggle and hiding it from sight. To be able to locate this hidden trim line, first (before the cowl is positioned onto the plane) go along the side of the plane and using a ruler, draw straight lines perpendicular to the firewall joggle. Make the lines about 4-6" long, extending aft from the joggle on the side of the fslg. Place them about every 6" around the circumference of the fslg. Then place a mark across each line a specified distance aft from the firewall joggle (let's use 4" but the dimension is not really important as long as you remember what it was).
13. Then place the cowl in position, secure it around the fslg with clamps and / or clecoes. Line up on each of the straight reference lines and extend the line onto the cowling. Then simply measure fwd the 4" and mark the cowl. That is the position of the joggle edge under the cowl. Simply connect the marks and cut the cowl. Simple, eh?



H. Cowling installation (upper cowl)

1. Trim the fwd vertical face (area behind the spinner) to the 1" flange dimension, in the same manner as the lower cowl. Trim the air inlet flange on the lower cowl to allow the upper cowl to be pushed onto the lower cowl joggle. This may be a tight fit initially but it will "break in" with time and heat to make what first appears to be a wrestling match into an easy assembly.

Trimming the air inlet flange on the lower cowling

Figure 21-18

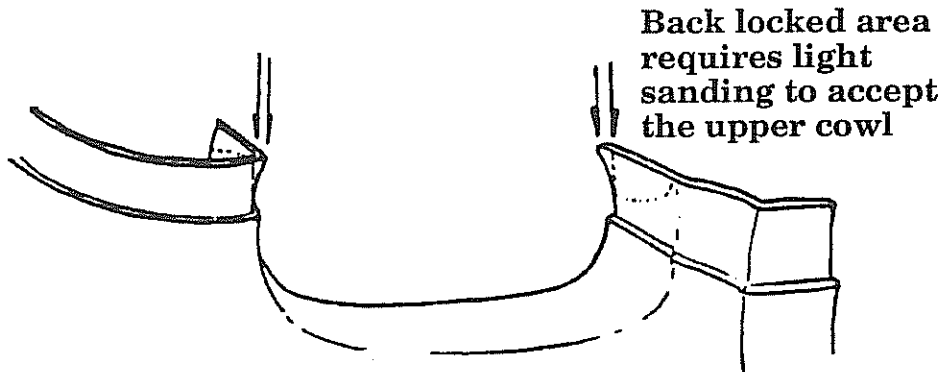

Forward deck / upper cowl - alignment:

2. If you have not yet firmly established the fwd deck position (and it is best of you have not) then this can be done now. With the upper cowling on, adjust the trailing edge of the fwd deck up or down until a smooth transition line is formed between the deck and the upper cowl.
3. With the upper cowl on, trim as necessary to achieve a good fit between the two cowls along the sides and along the firewall. The upper cowls generally have a little extra over run along the sides to allow some shifting for the best fit. Usually just a long flat sanding board is used here so that the part line remains smooth and straight. Drill and cleco both the cowl and fwd deck to lock in this alignment (be careful to locate the holes in a position to be used for final screw attachment).
4. At this point there may be a gap between the 3 BID firewall flange, that was applied in chapter 11, and the under side of the fwd deck / cowl joggle (be sure that you have secured the fwd deck / upper cowl alignment with clecoes). With a flashlight, sight under the fwd deck, looking fwd to how much gap is apparent. The following procedure should solve the condition:
5. Remove the clecoes, remove the upper cowl and the fwd deck.

6. Apply release tape to the underside of the fwd deck and upper cowl along this flange.
7. Sand (rough up) the flange. Apply flox to the top of the flange, release fit the fwd deck and upper cowling.
8. Remove the fwd deck / upper cowl, trim the floxed flange of squeezed-out excess and check for pits or voids in the fit. Re-flox / release fit if necessary.
9. With good flange contact achieved, proceed to installing the mounting screws with the exception that longer screws may be necessary along this flange, see figure 21-19.

Firewall flange build up

Figure 21-19

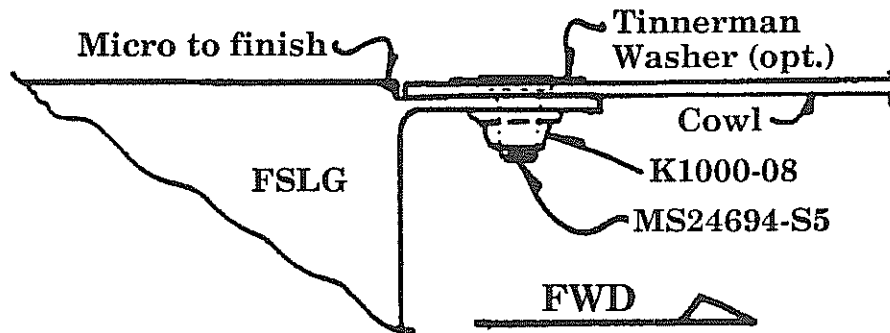

NOTE: Some builders may prefer to purchase and use Cam-Loc fasteners which are of the "quick" 90° turn disconnect type. These can be purchased from Aircraft Spruce, Wicks, and many other places. Use the style 2600 (button head) or style 2700 (flat head). The grip length will vary somewhat but usually the "dash-7" length is correct for most of the cowling. Often the "dash-8" is needed for the cowl to fslg attach areas. The series 2600 and 2700 use the same receptacle barrel.

10. With the fit established, mark for the attachment screws, see figure 21-19. The various locations along the cowl will require attachment screw spacing as follows:

Upper cowl to fslg	-	-	spaced approx. every 3"
Lower cowl to fslg	-	-	spaced approx. every 4"
Cowl sides to each other	-	-	spaced approx. every 5"

NOTE: The inbd fwd section just behind the spinner where the two cowl halves join should have two (2) attachment screws per side, see figure 21-20.

Cowling attachment screws

Figure 21-20

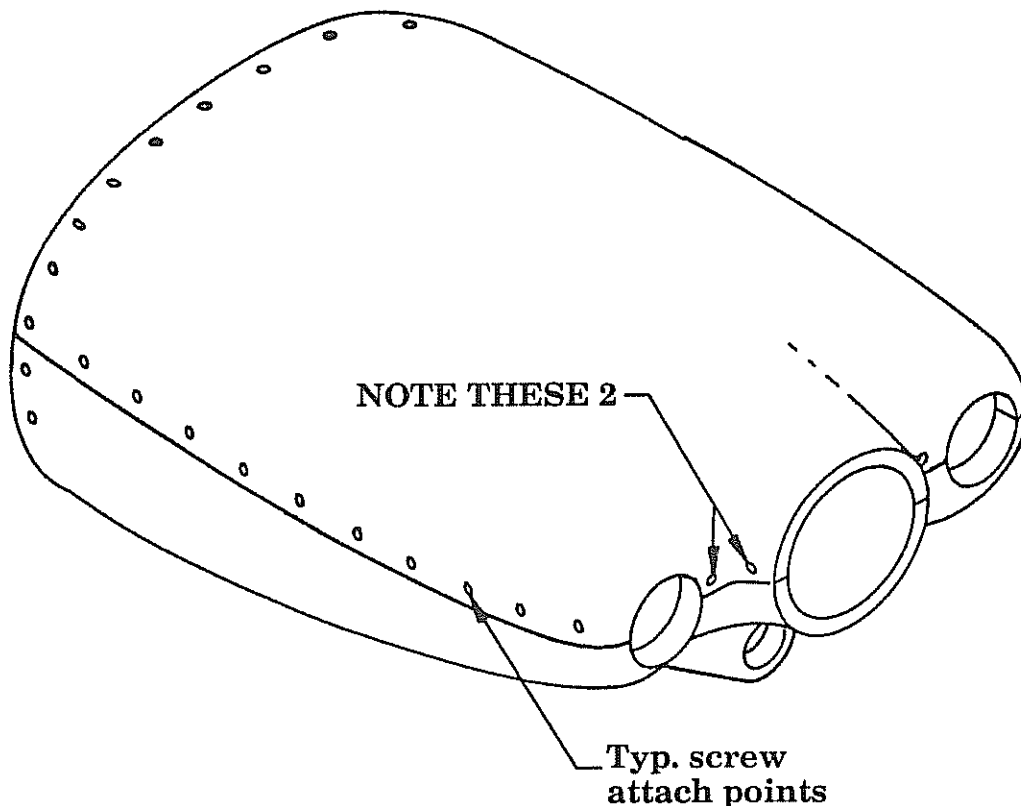

11. Standard kits are supplied with MS24694-S5 machine screws for cowl fastening. Use K1000-09 anchor nuts with these. For better wear against the fiberglass cowl, Tinnerman washers can be added, they are basically washers with a countersunk feature stamped into them. They can be glued onto the cowl sections and painted with the cowl.

NOTE: If the alignment of your cowling to the spinner is off a little bit, you can compensate for it by applying micro to the side that is short and cover with 1 BID to protect it. You should be able to fit it pretty close but sometimes the variables all add up on one side of the cowl and a perfect fit does not seem achievable. Remember to keep the minimum recommended clearance between spinner and cowling of 1/8" to 1/4".

12. If you need to change lower cowl scoops, simply position the cowl, cut off the old scoop and install the modified scoop. Allow for a flange of approximately 1" all around the perimeter of the attachment and attach using clecoes. Bond into position with epoxy / flox and add 1 BID on both the inside and outside edges.

I. Engine baffling

If you're building your own baffling system, use the blueprints for cutting and folding the aluminum. The best material is generally considered to be 6061-0 x .040" thick. This material is less prone to cracking due to its soft condition. The prefabricated baffle kits that we supply are made with this material, they are fully cut to size, bent and come with the required high temperature flexible sealing material, rivets, screws and anchor nuts. (If you hate work with aluminum anywhere near as much as we do, then you should surely consider the baffling kit to be a wise investment!)



21-33

Chapter 21

REV.

0 / 11-1-91

ENGINE INSTALLATION - LYCOMING



Engine baffling Assembly

Figure 21-21

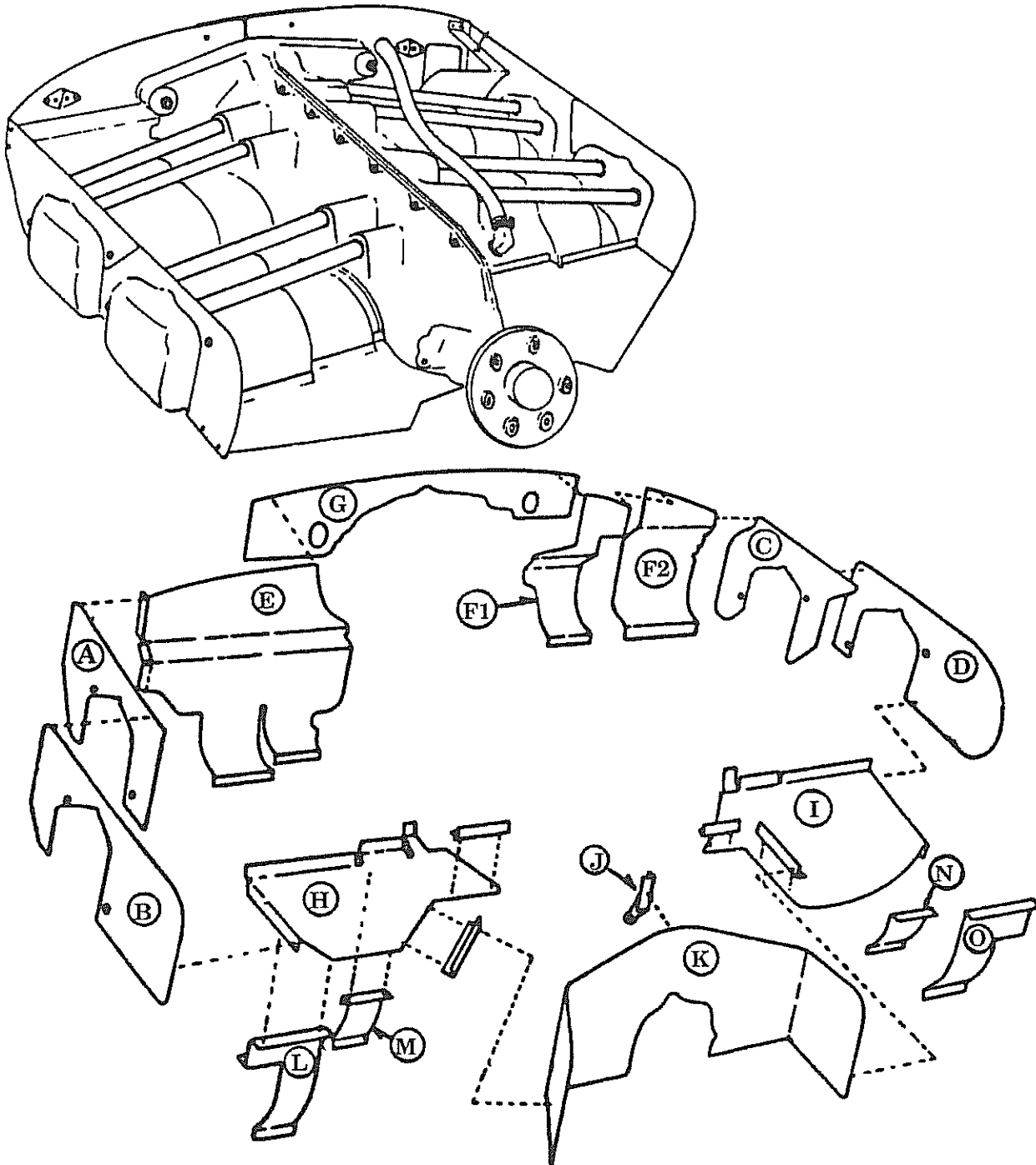

5. Lycoming O-320 and IO-320 Engine baffling installation

Engine baffling is very critical to the safe operation of your engine. The basic approach of baffling is to create a high pressure chamber on the upper side of the engine through the use of the baffling material and the upper engine cowl. A flexible sealing material must be attached to the aluminum baffling to assure a fit that is as close to airtight as possible. The primary cooling for the engine is accomplished by forcing air over and between the cylinder fins. This air **MUST** be forced to flow along the cylinder fins. If it is allowed to escape in other areas due to poor baffling, the cylinders will not cool adequately and a hot engine will be the result.

A hot engine can be anything from a slight nuisance to a very serious problem capable of seizing an engine in a matter of seconds on the first take off climb!

Standard 320 baffling kit materials:

Qty.	Description
1	Panel A (cylinder #3)
1	Panel B (cylinder #1)
1	Panel C (cylinder #4)
1	Panel D (cylinder #2)
1	Panel E
1	Panel F-1
1	Panel F-2
1	Panel G
1	Panel H (right front)
1	Panel I (left front)
1	Panel J
1	Panel K
1	Panel L (lower right front cylinder fin plate)
1	Panel M (lower right front cylinder fin plate)
1	Panel N (lower left front cylinder fin plate)
1	Panel O (lower left front cylinder fin plate)
2	7" x 3/4" x 3/4" alum. angle (cut to make 2 pcs. per length)
110"	2" wide flexible seal strip
40"	3" wide flexible seal strip
32	AN525-832 machine screws
32	K1000-08 nut plates
64	AN426-3-5 rivets for nut plates
12	AN470-4-4 rivets for angle stock attachment
8	AN500-A416-10 valve cover screws
2	Spark plug wire guides
4	AN525-1032 machine screws
4	AN365-1032 lock nuts
4	AN960-10 washers
120	Pop rivets (wide head for flexible sealing strip)

A. Aluminum baffle plates

NOTE: The baffles are pre-fit for conical mounted engines. The dynafocal mounted engines will require clearance cutting around the larger dynafocal ring to fit.

1. First take the aluminum pieces and lay them out on the floor (refer to figure 21-21). This should help sort out what may seem like a real mess at first since many pieces seem to at first look alike.
2. Begin by attaching the side plates (A, B, C & D) using the valve cover tapped holes with the AN500 screws as anchor points. Each of the side plates will have two mounting holes near the valve covers. These plates will overlap between the cylinders. This separation between cylinders is to allow for expansion of the cylinders when they are hot. They should NOT be rigidly connected between the cylinders, as the cylinders will expand and contract with heat.
3. Position the (G) center plate onto the engine.
4. Position the right rear plate (E) first and adjust the curvature as necessary so that the cylinder fins are contacted by the plates as they follow the cylinder down and around its rear lower circumference. Check that you can access the engine mount bolt at the top through the hole in the (E) plate. Clamp the rear baffle plate in position and drill for two or three attach screws. Drill through both the (A) and (E) panels and secure anchor nuts onto the (E) panel.
5. Next position the left rear baffle plates (F1) and (F2). This side is made up of two pieces (one inner and one outer plate). Again, adjust the curvatures so that they contact the cylinder in a snug manner. Adjust as necessary and clamp into position. Bolt the two (F) panels in position using the AN525 machine screws. Bolt the outbd rear (F) panel to the rear side panel (C) using two (or three, if desired) machine screws and anchor nuts in a manner similar to that used on the right rear side.
6. Position the fwd panels (H) and (I). These panels must slant downward with the leading edge being low. The proper angle should be checked using your engine cowl as a reference since the panel must dip below the bottom of the circular air inlets. The actual amount below is not critical but plan for about a half inch below. You can use small clamps to secure in place to make a cowl check or simply hold them in the proper position as someone else marks a reference line on the side panels. Note that the side panels may require trimming prior to fitting the cowl up into position. Also, the tops of the panels may require trimming as well, use the upper cowl as a trim guide for them.



This baffle plate fits between the cylinders

TOP VIEW
Full size
2 required

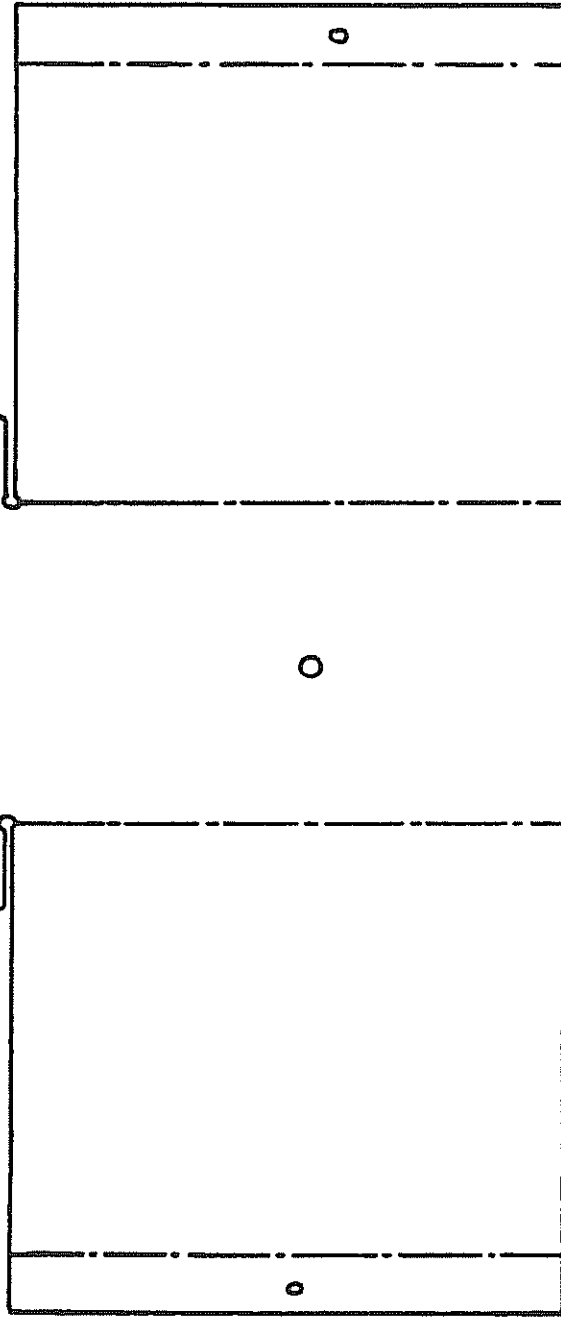

SIDE VIEW
(folded)

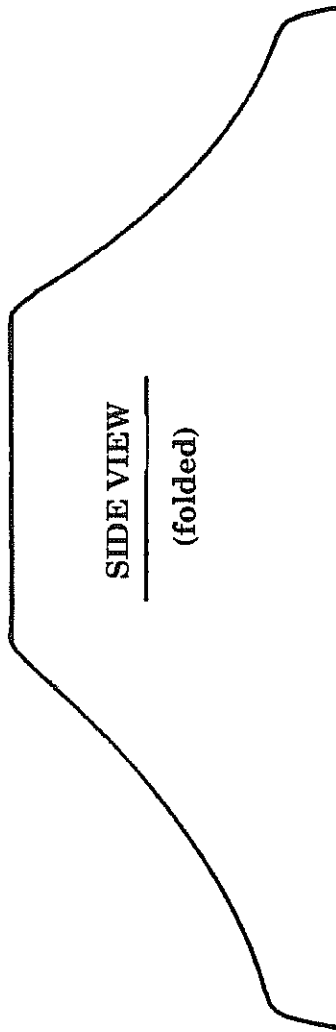

Center Cylinder Baffling
@ lower center fins
Figure 21-22

3/4" x .125" Al. pc
slips into fins

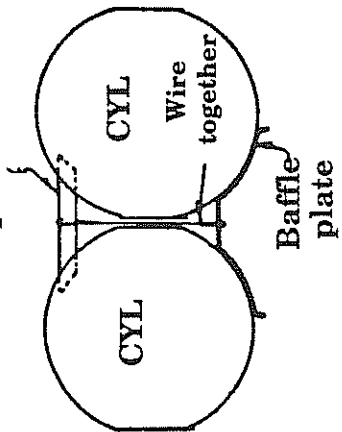

7. With the front two panels in position, place the center front panel (K) over the engine case and check its alignment with the side two panels. You will use the bent angle stock to connect the center panel with the front side panels.

This center front panel (K) is attached using the fitted angle piece (J) which attaches to the engine case bolt. Use one or two machine screws to attach the angle piece (J) to the center piece (K).

8. Use the AN470 rivets to permanently attach the angle stock pieces to the vertical sides of the fwd center plate (K). Then use machine screws to attach the angle stock to the front lower plates (H) and (I).
9. If you are running a constant speed propeller, you will need to make a passage hole in the right front plate (H) to clearance the stainless steel oil line for the prop. Also, if you are running fuel injection, you will need a clearance hole for the fuel line that connects to the divider head located on the top of the engine. Both holes must have rubber grommets around them to prevent chafing.
10. With all the perimeter pieces now fitted into position, secure them with machine screws, see figure 21-24.
11. Next fit the lower cylinder fin plates. These are important since they maintain airflow around the cylinders as the cooling air moves downward and out. Attach the four forward curved plates by positioning them under the (H) and (I) panels and attaching with machine screws per figure 21-21.

NOTE: A center flow baffle plate is normally supplied with the engine. If your engine does not have one of these, then they should be fabricated and held in place with safety wire running up through the cylinder fins to a cross brace on the top side of the cylinders. See figure 21-22 inset.

12. It is also recommended that you wire the bottoms of the lower baffle plates together so as to keep them snug against the cylinder fins. This will also help with cooling. Safety wire can be used or a small piece (1/8") all thread with lock nuts on the ends. See figure 21-23.



SECURING LOWER EDGE OF CYLINDER PLATES

FIGURE 21-23

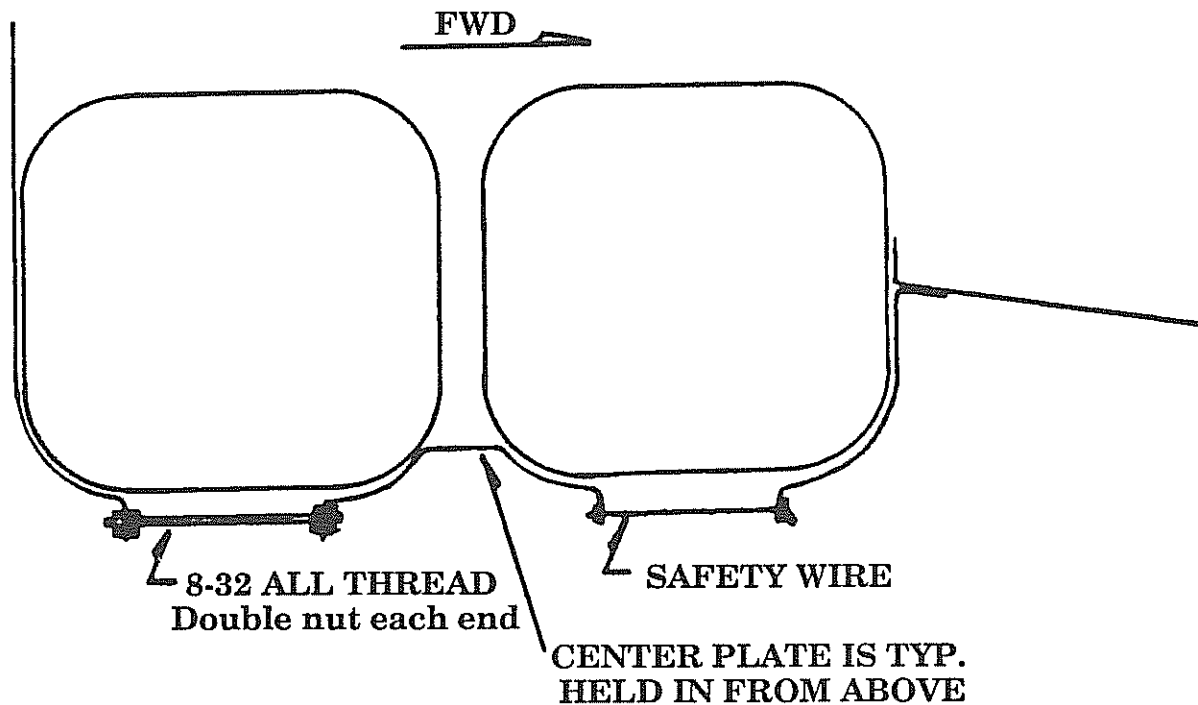

Lycoming 320 Baffling
Figure 21-24

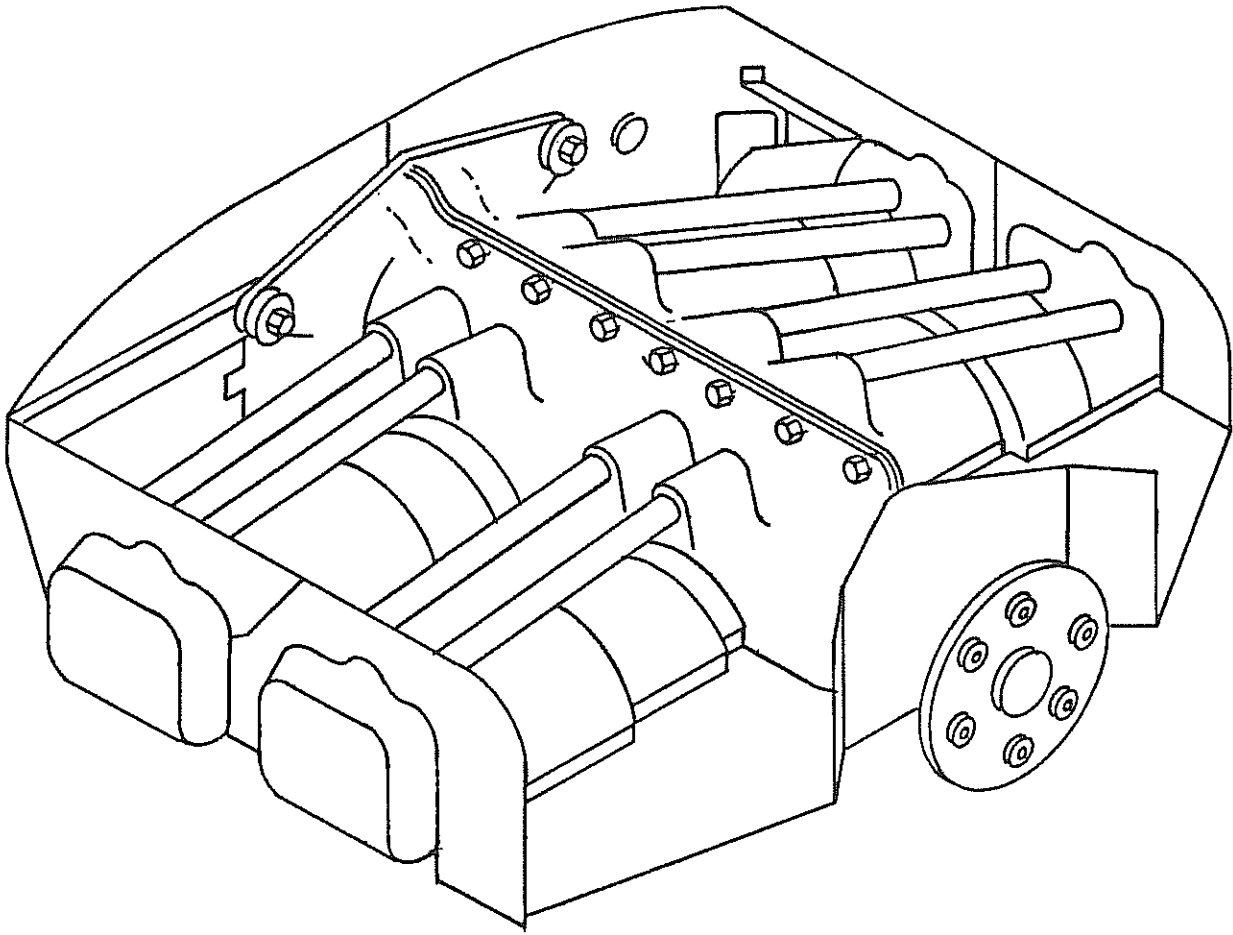

LANCAIR® 320FB

21-40

Chapter 21 REV. 0 / 11-1-91
ENGINE INSTALLATION - LYCOMING

B. Spark plug wire guides

1. These wire guides fit onto the rear baffle plates (E) and (F). Their exact location is not critical but they should be placed such that you will still have room for an oil cooler air line (3" dia.) pick up on the right side. The heat muff air line (2") on the left side can be run from the front (I) panel and routed around the cylinders to the back where the heat muff is located since there is little room on the left rear (F) panels for that 2" line installation. See figure 21-24 and 21-25 for installation of these spark plug wire guides.

The access hole is easiest made by drilling a through hole first then following with a router bit in a rotary type cutter to carefully enlarge to the dimensions shown.

PLUG WIRE GUIDES

Figure 21-25

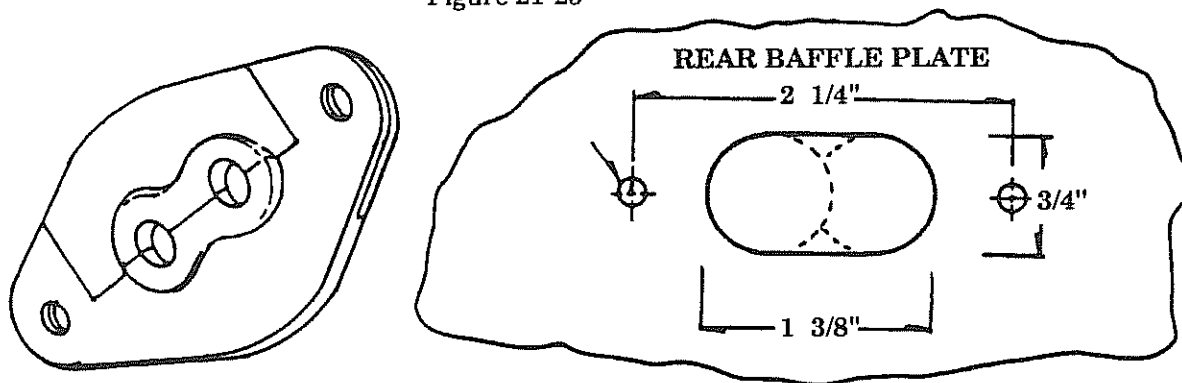

THIS NYLON TIE KEEPS
CABLE OR WIRE FROM
CHAFING ON MOUNT

CABLE OR WIRE
BEING TIED
OFF

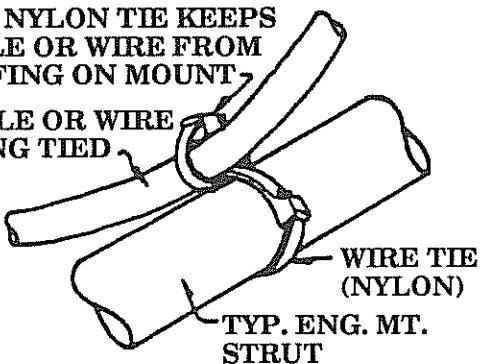

WIRE TIE
(NYLON)

TYP. ENG. MT.
STRUT

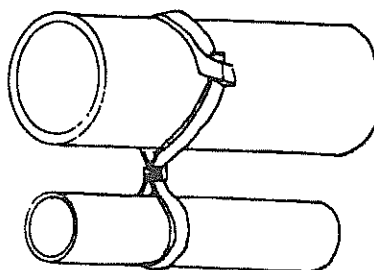

USING 2 TIE-WRAP
TO SEPARATE HOSES

C. Rubberized sealing strips

1. This rubberized flexible material (black) is supplied in two widths, 2" and 3". Generally, we use the 2" all around except at the front where the 3" is used around the circular air inlets since it is doubled back on itself at those locations.
2. Referring to figure 21-27, place all sealing strips on the inbd sides of the vertical baffling plates, overlap it where the carious pieces meet so that each individual baffling panel can still be removed with its own flexible sealing strip attached. Use the wide headed pop rivets to attach this sealing strip.
3. The sealing strip should ALWAYS bend inward as well which assists in maintaining a good pressurized seal against the top of the cowling as air pressure builds. (It is this created pressure differential between the upper top chamber and the lower cowl area that forces the cooling air past the cylinder fins thus a good seal is very important regarding safe cooling and drag reduction.) Also remember that cooling drag is a very substantial amount of the overall drag at upper altitude cruise so the less leakage the faster you'll go!
4. The sealing strip that fits to the front vertical panel (K) will attach to the BACK side of it and fold AFT.
5. You now have just the two air inlets to seal around. Attach the sealing strip (use the 3" here) once again to the inside faces of panels (B) and (D) along their vertical fwd faces. These strips will extend fwd and double back towards the circular inlet side, thus they will tend to seal tighter as air pressure builds.
6. In a like manner, attach the sealing strips to the top surfaces of panels (H) and (I), extend the strips fwd and double them back in an upward direction or again towards the circular inlet side. Where the strips meet at the 90° intersections will require a bit of folding to effect a good seal.
7. These strips will make the first few installations of the upper cowling seem difficult. As the strips get hot a few times, they will take a "set" and from then on the cowling will slip down into position very easily.
8. When first installing the cowling be sure to reach inside through the circular inlets, oil access door, etc. to insure that the seal strips are in fact curling inward and not outward.

WARNING: The seal strips MUST curl inward in order to effect a good seal during flight. Failure to assure this could result in overheating of the engine and possible engine damage.



9. It is sometimes helpful to slit the seal from the top edges downward a little ways which will help attain the somewhat compound curved fit that is necessary for a good tight seal all around the perimeter.

NOTE: As the first flight hours are made, inspect the baffling seals and note the rub patterns on both them and the upper cowling. You will easily be able to see any places where the seal strips are not contacting the cowl. In these areas, you will then have pressure air leakage which detracts from good cooling and low drag. Make adjustments as necessary to attain a good seal all the way around.



D. Silicone sealing

1. Finally, for a good seal that produces maximum cooling and minimum drag, use some high temperature silicone around all areas that must seal against the engine. This is primarily around the front engine case areas. Simply place a nice smooth bead between aluminum plates and the engine case. Another area of particular benefit is around the rear engine accessory case.
2. Also note that the front left panel (I) is an excellent location for a sponge type remote air filter for the carb or injector. A fiberglass box can be fashioned and attached to the bottom such that it holds the filter directly under the panel, a large hole is then cut into this panel for the largest possible filter installation (see figure 21-33).



E. Oil cooler air line

1. Your engine will require a 7 to 9 vane oil cooler, in other words, it needs a pretty good sized cooler. The best high pressure air source for the cooler is from the right rear baffle panel (figure 21-21, panel E). Attach a 3" flange to accept a length of 3" Scat tubing which will be run to the oil cooler plenum. A flange can be pop riveted to the (E) baffle panel and extend aft. The oil cooler installation will be discussed in more detail later but in general, it can be located on the left lower side of the firewall (see figure 21-1). The 3" Scat tubing will cross over the top rear of the firewall and down to the cooler where it should enter into a fiberglass plenum attached to the top of the cooler. 1/2" oil lines should be used from the engine to the cooler. See figure 21-26 for a typical oil cooler installation onto the firewall.
2. Refer to figure 21-26 for a simple method of making a Scat tube attachment. It is shown for a typical piece of 3" Scat tube but the principle will work well for any size as long as it doesn't get too small. Attach the Scat tube with some high temperature silicone and very light clamping pressure from a hose clamp that is placed close to the face of the sheet metal surface.



TYPICAL OIL COOLER INSTALLATION

Figure 21-26

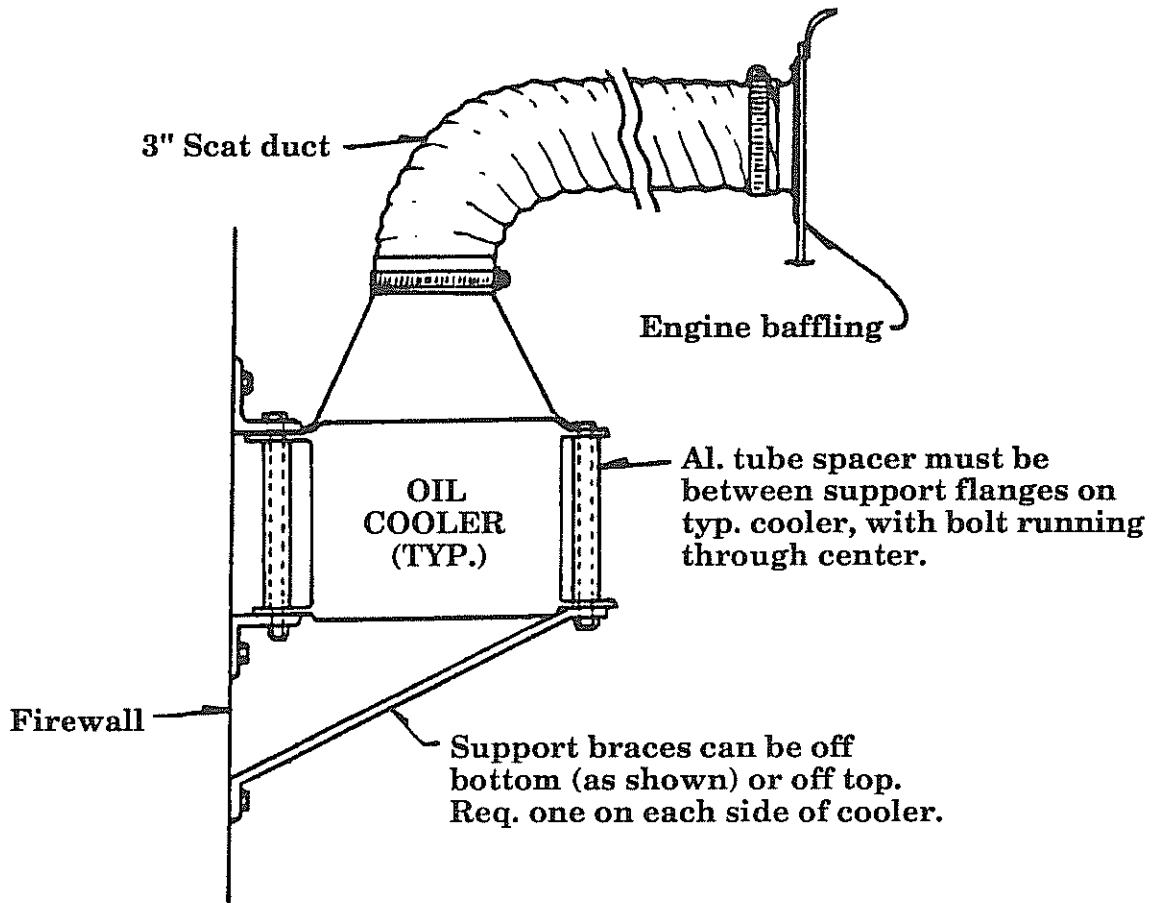

Forming scot tube attachment

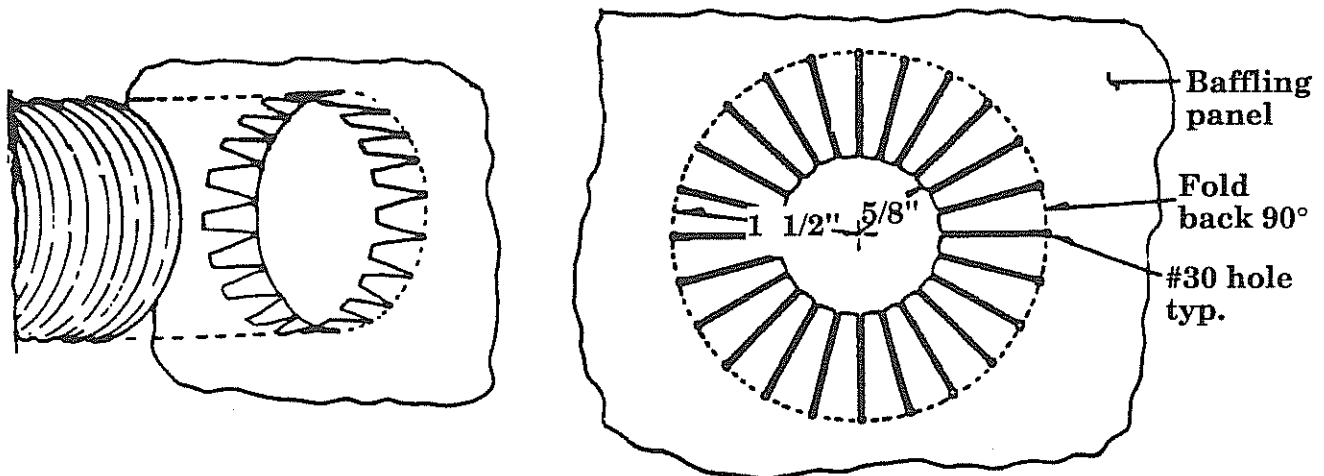

BAFFLING FLEX SEAL

Figure 21-27

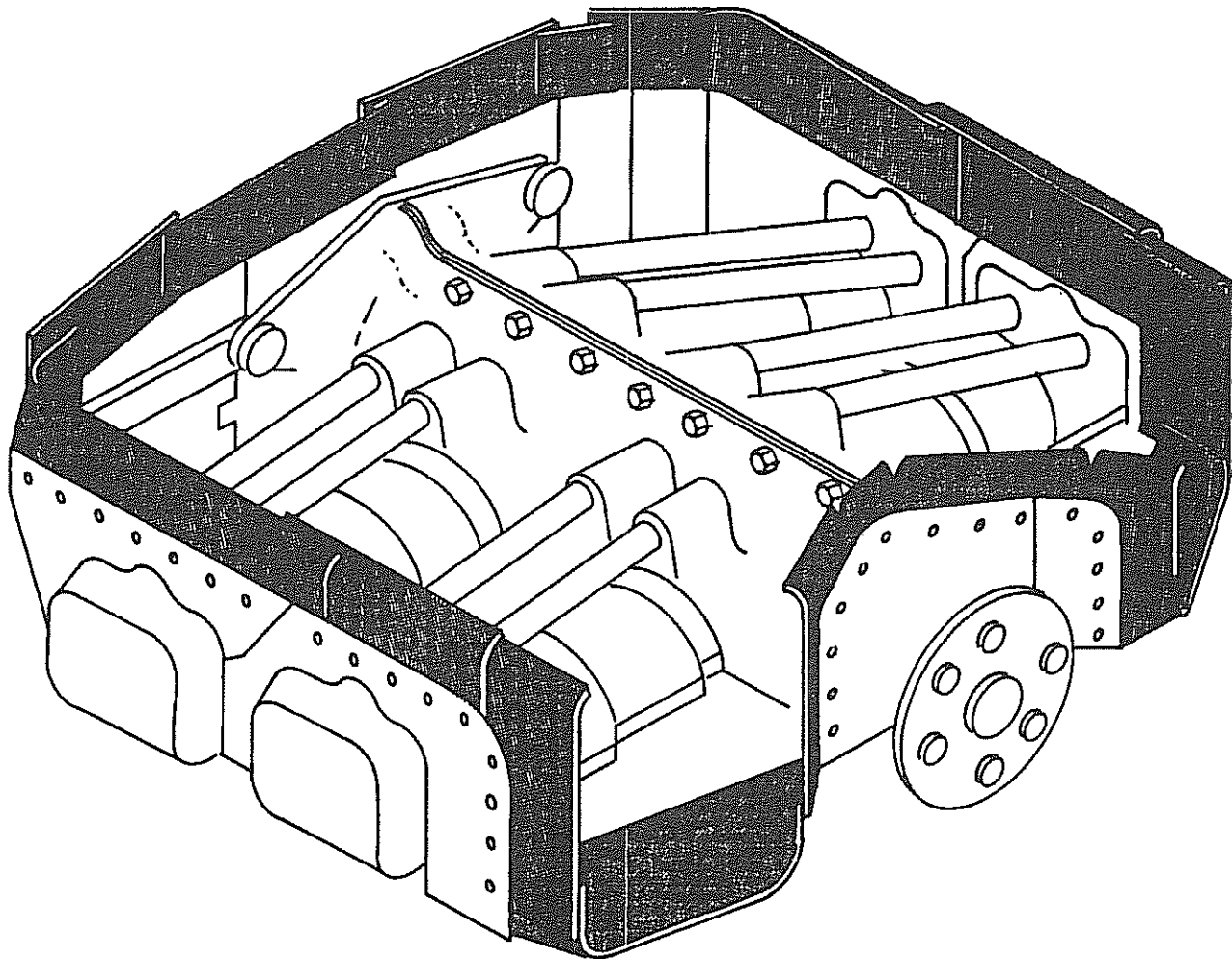

F. Magnetos

Wiring up a pair of mags is very simple, about as simple as the 1930's era mag that it is! Essentially, the mag is "hot" all the time and must therefore be grounded out to kill the spark. The mag switch merely grounds out the mag in the off position. Mag wires should always be run with shielded cable so that the contacts do not interfere with radio and Loran C signals. A #20 wire gauge is sufficient.

Magneto filters are also a good idea since they will further filter noise from the system. They are available from most repair stations and catalog houses. You can use individual on/off switches for the mags or a keyed type rotary switch (Bendix type).

The upper plug leads location is not critical and should thus be located after oil cooler locations and blast air line locations have been calculated.

NOTE: It is often considered advisable to have a separate starter switch (i.e., a separate starter button instead of the Bendix type mag switch with the starter position on it). The reason for this is inertia. If you have the means of first getting the engine spun up before switching on the mags, your inertia is increased and a kick back is avoided. If the engine were to kick back while the starter is engaged, it could break the starter gears or starter housing.



G. Remote oil cooler mounting

The Lycoming 320 and 360 MUST have an oil cooler to keep temperatures within the recommended operating limits. Due to the tightness of this engine installation, there is a recommended location for the 9 vane oil cooler, mounted to the firewall as shown in fig. 21-1. (However, with careful planning and layout, other locations may be possible.)

1. First a shroud must be made out of 3 BID fiberglass (or aluminum) per figure 21-28. This shroud must make a transition from the 4" x 7" rectangular oil cooler to the 3" round flange for the Scat duct. The Scat duct must pick up air from either: a NACA duct formed in the side of the lower cowl, or from the aft wall of the baffling (piece E).

NOTE: If the pressure cowl location is chosen, one must make sure that the nearest cylinder is not robbed of its needed cooling high pressure air. During the first flights, monitor temperatures within the engine compartment, and note the temperature of the rear cylinders, especially the one over which the oil cooler air is being drawn. If it is running hot, it may not be getting the proper air flow due to the flow to the oil cooler, in which case step 2, below, is recommended to assure proper high pressure air to rear cylinder which is nearest the oil cooler air inlet.

2. Add a curved flange, see figure 21-29, behind the cylinder fins and extending upward and fwd thus helping to trap pressure air and route it down through the fins of the back cylinder.
3. Use a standard 3" flange and attach it to the back baffling piece (E). This places the air inlet on the left side of the plane, and the air pick up flange (on the oil cooler) on the right side, subsequently the Scat hose must be about 36" long to route between the two.
4. Mount the oil cooler to the firewall in the location shown in figure 12-1. It must be very securely mounted to prevent the possibility of cracking from vibration. The standard Harrison type of coolers have two sides that attach, both sides must be supported. Do not simply hang the cooler from only one flanged side, it would fail, see figure 21-26.
5. Clamp the 3" Scat duct to the baffle flange and to the shroud flange with screw type hose clamps.



SHROUD, OIL COOLER

Figure 21-28

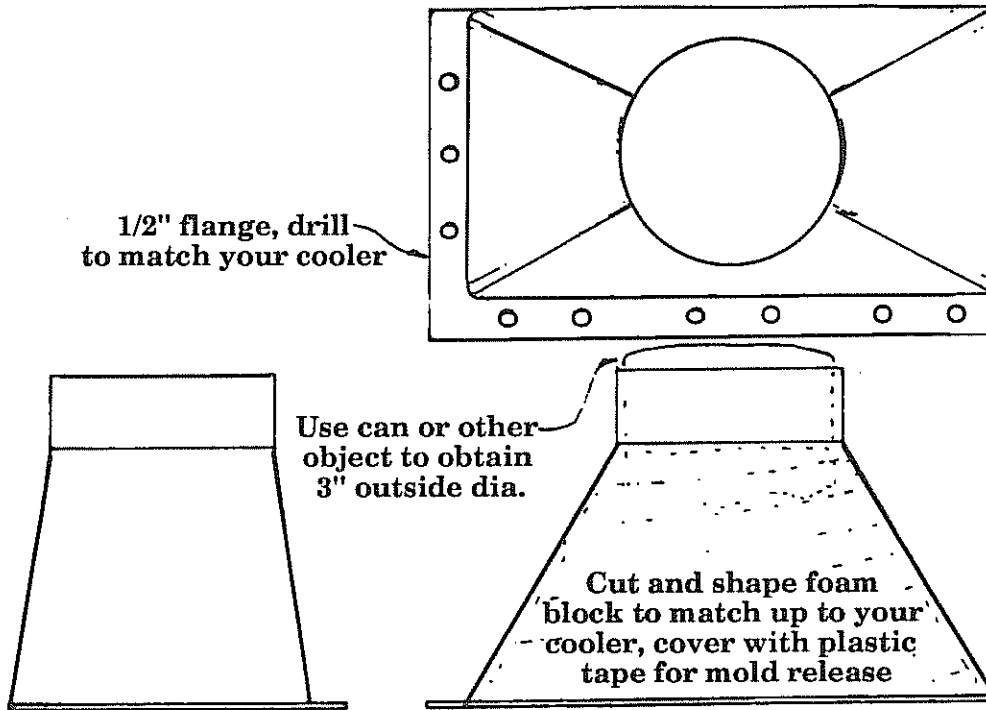

BAFFLING, FLANGE - REMOTE OIL COOLER

Figure 21-29

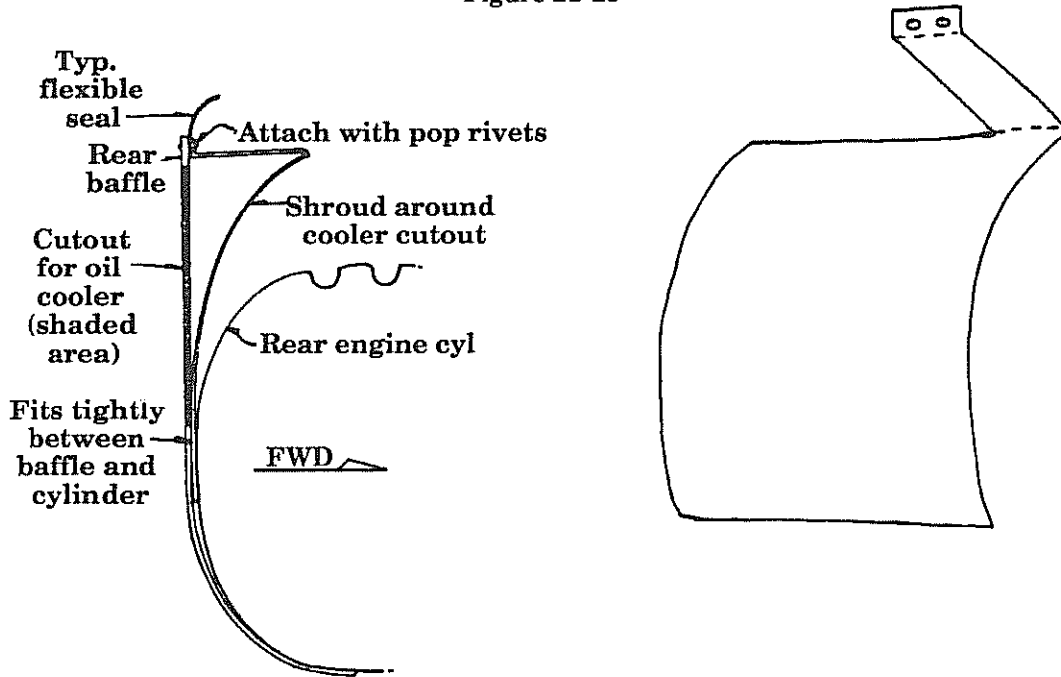

H. Spark plug leads

The upper plug leads should be routed through nylon two piece housings (supplied with the baffle kits) which attach to the rear baffling pieces (E & F). Their location is not critical and should thus be located after oil cooler location and blast air line locations have been calculated.

1. Mark the location where the lead wires will pass through the rear baffle plate. Punch two 3/4" holes, 5/8" off center from each other and file out the middles, thus producing an oval that is approx. 3/4" x 1-3/8" to accept the two piece housing for the upper plug leads, see figure 21-25. Attach the housings with two AN526-132 machine screw and AN365-1032 nuts.

NOTE: The AN365-1032 nuts are rated for up to 250° F environments. Our engine compartments have consistently proven to run from 130° F to 150° F. If your engine compartment gets any hotter, the all metal nuts should be substituted. Thus, it is highly recommended that a temperature probe be run in the rear center engine compartment to monitor temperatures early in the test flight program.

2. Be very careful to protect the leads against any possible friction points around baffling pieces, etc. Leads can be tied with nylon zip ties, the best method of using these ties is the double tie method, and is shown in figure 21-25. With this double tie approach, the cable or wire is securely anchored just OFF the fixed location with nylon between it and that hard spot.
3. The lower plug leads obviously do not run through the baffling but care must be taken to assure that they will not be subjected to chafing or direct contact with exhaust pipes. Secure the lower plug leads with the same method as used above.



I. Exhaust system

The Lycoming exhaust systems that we manufacture are stainless steel full crossover systems. There are several different models of exhaust, depending on the type of engine used. Please consult with our technical staff when selecting your exhaust system.



21-52

Chapter 21

REV.

0 / 11-1-91

ENGINE INSTALLATION - LYCOMING



J. Cabin heat system

Obviously cabin heat is not a necessity (higher latitudes excluded) but it is generally installed even for us Southern California residents. A minimum of heat is required in a well sealed cockpit, our standard heat valve is 1 1/2" dia. and more than sufficient (see figure 21-30). **THE CABIN HEAT MUST BE FED WITH FRESH AIR ONLY.**

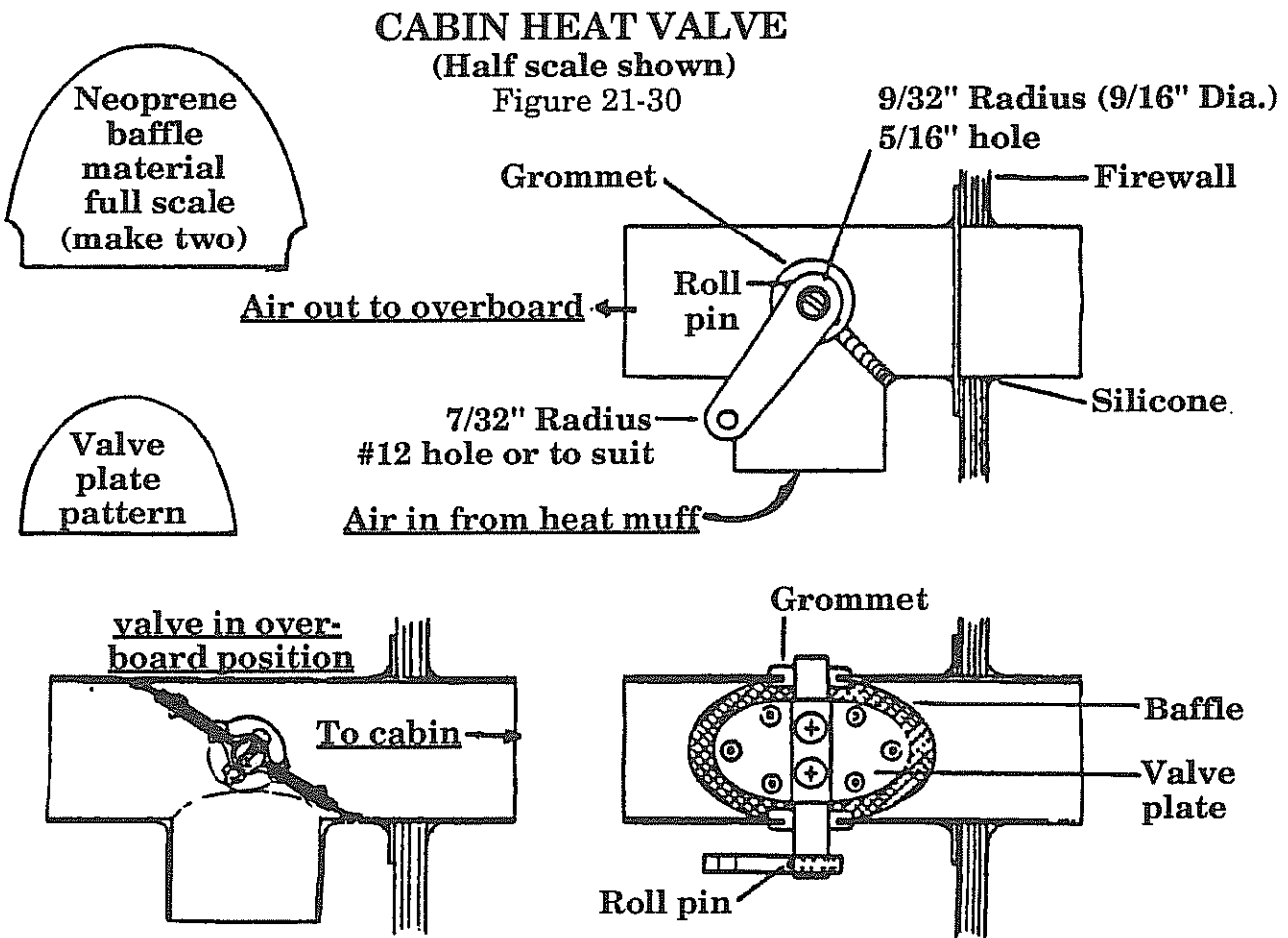

- Heat muff locations will vary with the style of exhaust required. Position the air duct flanges on the hat muff shell so that they are in the best possible position to run a duct fwd to a fresh air inlet flange and to run a duct aft to the firewall cabin heat valve (this may need readjusting when the ducting is routed, so keep the clamp screw on the heat muff in an accessible spot).



2. From one of the hose coupling flanges, on the heat muff, connect a piece of Scat ducting of 1 1/2" dia. This will typically be routed fwd to baffling piece "K" (this, long way around, routing is to leave room for the air filter installation on baffling piece "I"), install a duct flange here to pick up the fresh air.
3. Connect a piece of Scat ducting of 1 1/2" dia. to the remaining heat muff flange. This will be routed aft to the cabin heat valve located on the firewall per figure 21-1 (if the cabin heat valve was not already installed, install it now per figure 21-30).
4. The Scat duct from the heat muff must attach to the valve per figure 21-30.

WARNING: Incorrect installation of the cabin heat system could allow toxic fumes into the cabin. THIS COULD BE FATAL!

5. The heat muff is always producing heat if the engine is running, even if the valve is closed. The overboard side of the valve should have Scat duct attached to it and extending down and pointing aft near the cowl air exit. This way the hot air will not be dumped directly into the engine compartment.



LANCAIR® 320FB

21-54

Chapter 21

REV.

0 / 11-1-91

ENGINE INSTALLATION - LYCOMING



K. Air intake system (engine)

1. Ram air is always the most effective induction system, but engine life is prolonged if a filter system is used when operating on the ground. The easy system is one of simply installing a coarse sponge filter to keep out the big particles. This is a very common installation whereby the air box is simply fitted with a coarse sponge type of filter.

WARNING: Be sure the filter does not overly restrict air entering the engine which could rob the engine of power. See figure 21-31.

2. To build a suitable air box, start with a block of foam and carve it to fit against the carburetor and extend forward to the inlet on the lower cowling (be sure you have the starter motor installed, to allow room for it!). A flat area should be maintained on the upper forward area where you can place an air duct flap for carb heat. Across this area, the corners should be relatively square and tightly radiused thus more suitable to a tight seal of the flap that will divert carb heat. A second flap can be installed to serve as a means for ducting remote filtered air. (This allows for a larger air filter to be placed on the forward left baffling plate which is ducted down to the carb air box, see figure 21-33 and figure 21-35.

When the shape is correct, cover the "plug" with plastic tape as a release. Then lay 4 BID over the upper half of the plug and allow to cure but during the "green" stage, when the BID is about 3/4 cured, knife trim to a point that is just below the middle of the sides. Discard the trimmed off BID. Allow the piece to fully cure.

3. You will next lay up 4 BID over the lower portion of the plug but first cover the lower 2" or so of the upper BID with plastic release tape. Then lay up the 4 BID onto the lower portion and extend over the cured 4 BID upper portion by about 1". Trim this in the green stage as well. Allow to cure fully.
4. Pry the lower half off the plug then pry the upper half off the plug. You now have two custom mated pieces that form a full airbox (see figure 21-31).
5. Fit the carburetor to the upper portion of the air box and attach that piece to the carburetor using the four holes in the carburetor base. These screws should be safety wired together.
6. The air box should fit into the fwd air duct on the cowl but don't fit it in too tight or else you will have a hard time removing the lower cowl. A micro fill of that forward 3/4" portion of the lower cowl air scoop will generally help the installation and removal of the cowl since there will be less of a tendency for the cowl to "back lock" onto the air box.



7. A **very coarse** sponge type filter (we've found a Cessna 150 filter, cut to fit, then split to half-thickness, to work well) can be installed directly onto the front of the air box. Be careful to secure a coarse wire mesh behind the filter with at least 4 BID to prevent the filter from getting sucked into the carburetor thus a wire mesh made of 0.050" wire with not more than 3/8" to 1/2" spacing is required aft of the filter (between it and the carburetor).
8. A more elaborate filtering method is also possible. Make a cover housing for a larger sponge type of filter on the front left baffling panel (see figure 21-33). Then route down with a 2 1/2" Scat duct to the flapper valve on the carb air box. This will thus allow full ram air when operating at altitude and filtered air when operating low and on the ground. This is obviously more work but it provides the best of both worlds (see figure 21-34). (Note: The airbox shown in figure 21-31 is available from Neico, and includes most of the parts and hardware shown).
9. One word of caution, if you are intending not to run any filter at all (many aircraft don't) you should then at least install a medium coarse screen across the front of the air box to prevent large foreign matter from entering the carburetor and possibly plugging it to the point of engine air starvation. This screen should also be well attached with typically 3-4 BID.
10. There are 3 different air intake configurations currently for the Lancair 320, depending on the type of engine, and its induction system, you have selected for your particular aircraft.
The standard 320 lower shroud (see figure 21-32 A) is designed for use with Lycoming 320 engines using a bottom mounted carburetor. If you are using an L320 with bottom mounted fuel injection, or an L360 with either bottom mounted carburetor or fuel injection, then you would use the shroud shown in figure 21-32 B, which has a deep 'belly' to accommodate our pre-formed air box (figure 21-31). For engines equipped with front mounted fuel injection, use the shroud shown in figure 21-32C.



AIR BOX CONSTRUCTION

Figure 21-31

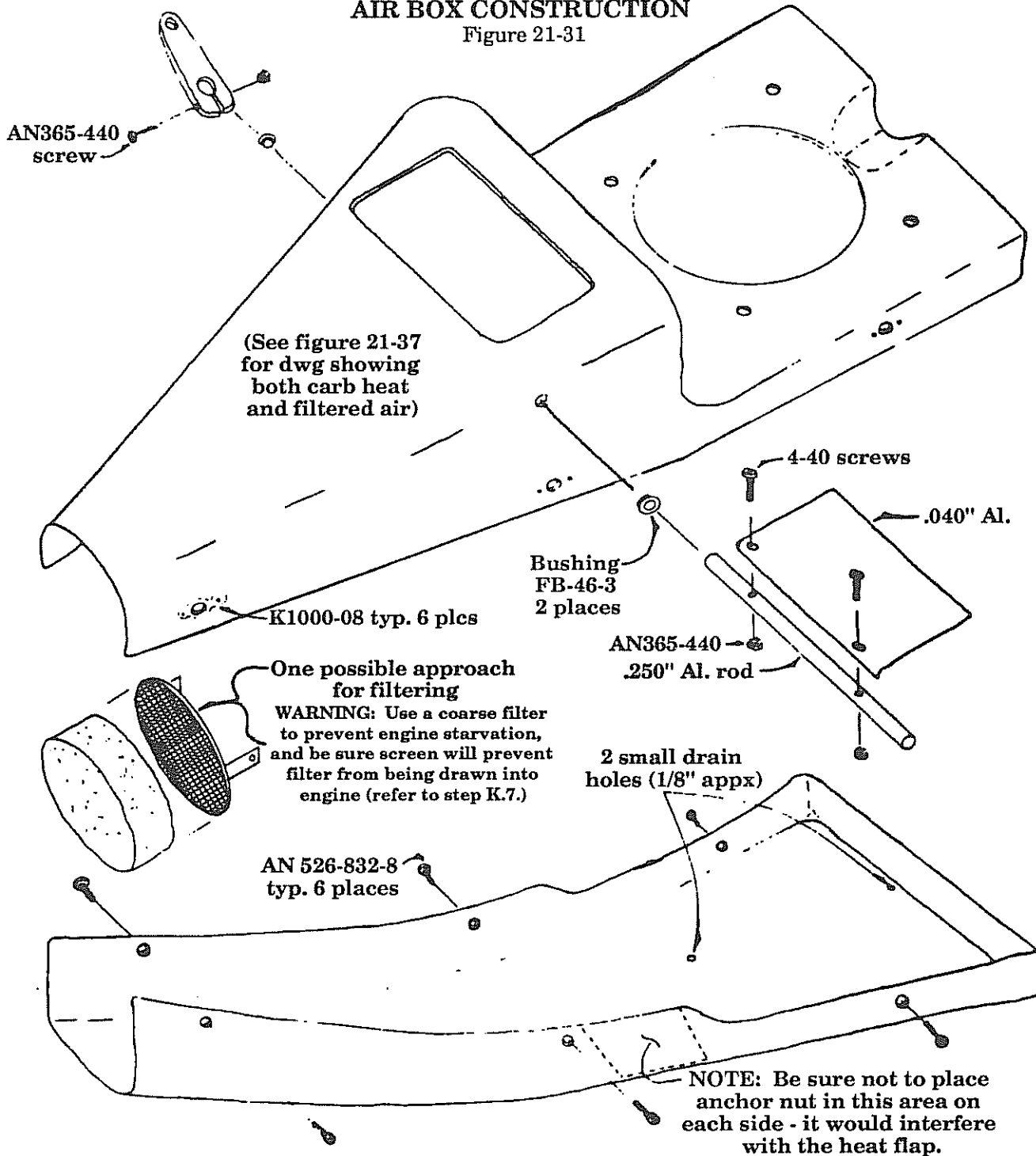

L320 Shroud configurations

Figure 21-32

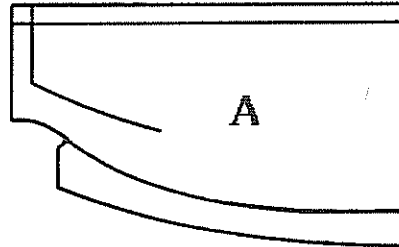
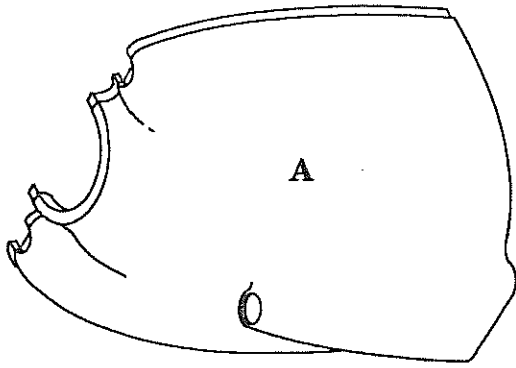

std. Carb.

EX-3/4-C

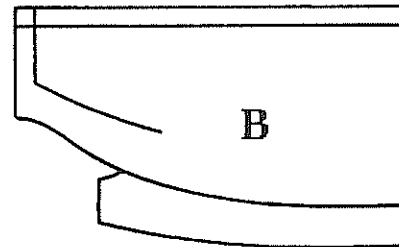
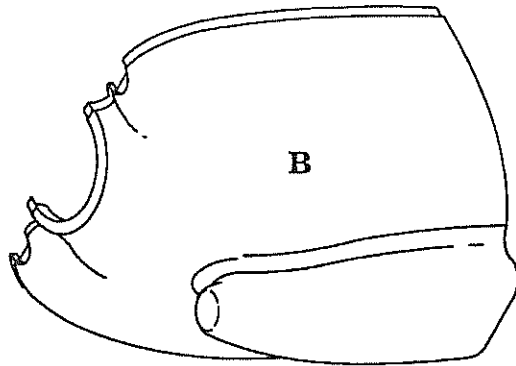

Bottom Mounted Injector
on Facing

EX-3/4-I

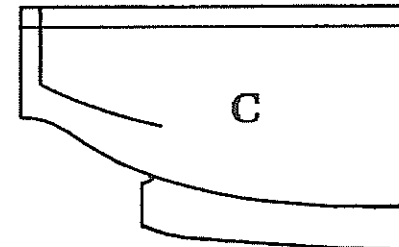
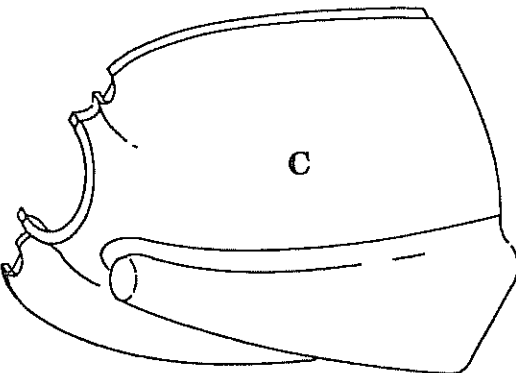

Forward Mounted Injector
on Facing

EX-5

exhaust system
✓

Remote filter air box assembly

Figure 21-33

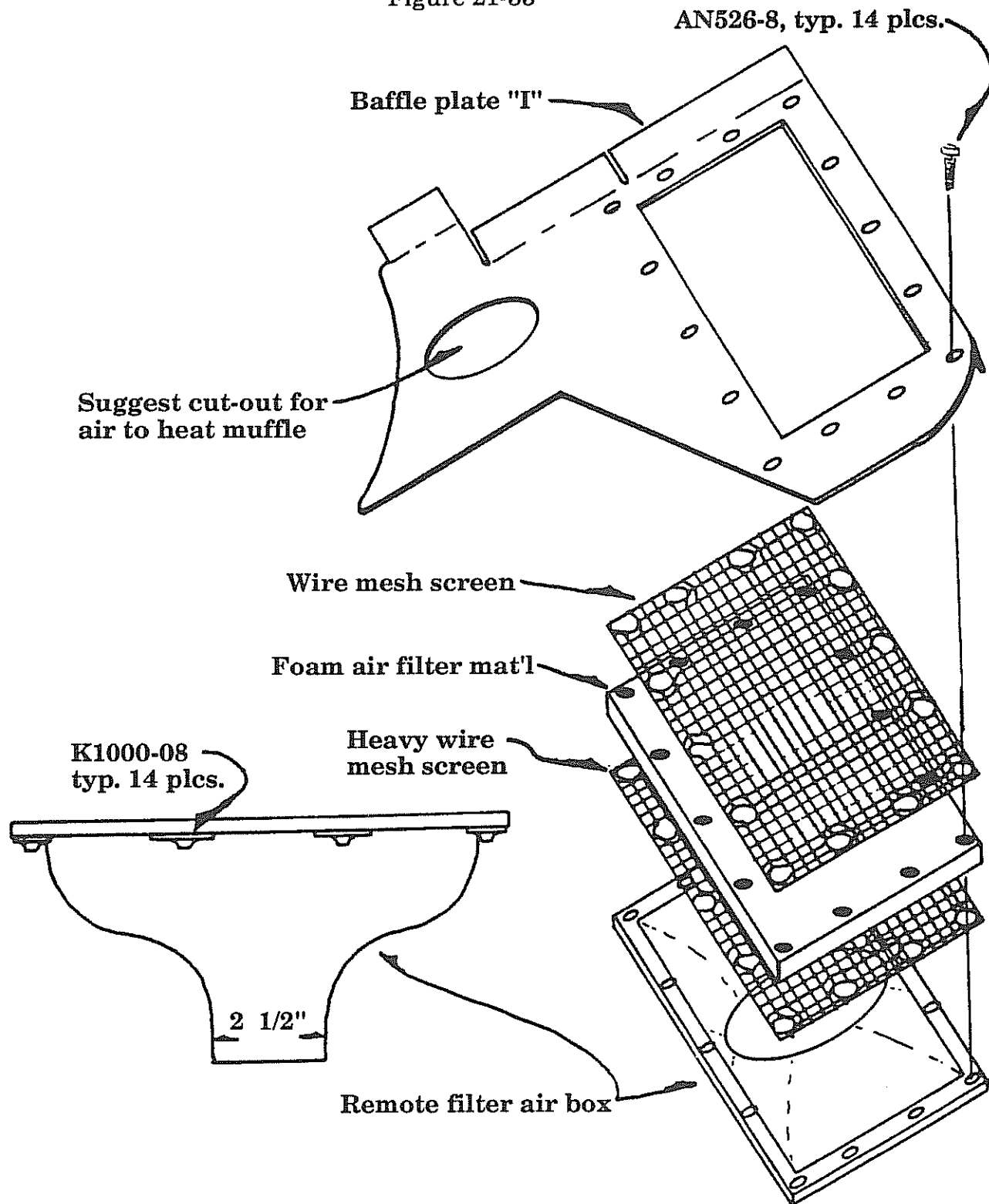

Typical ram / filtered air installation for front-mounted fuel injection

Figure 21-34

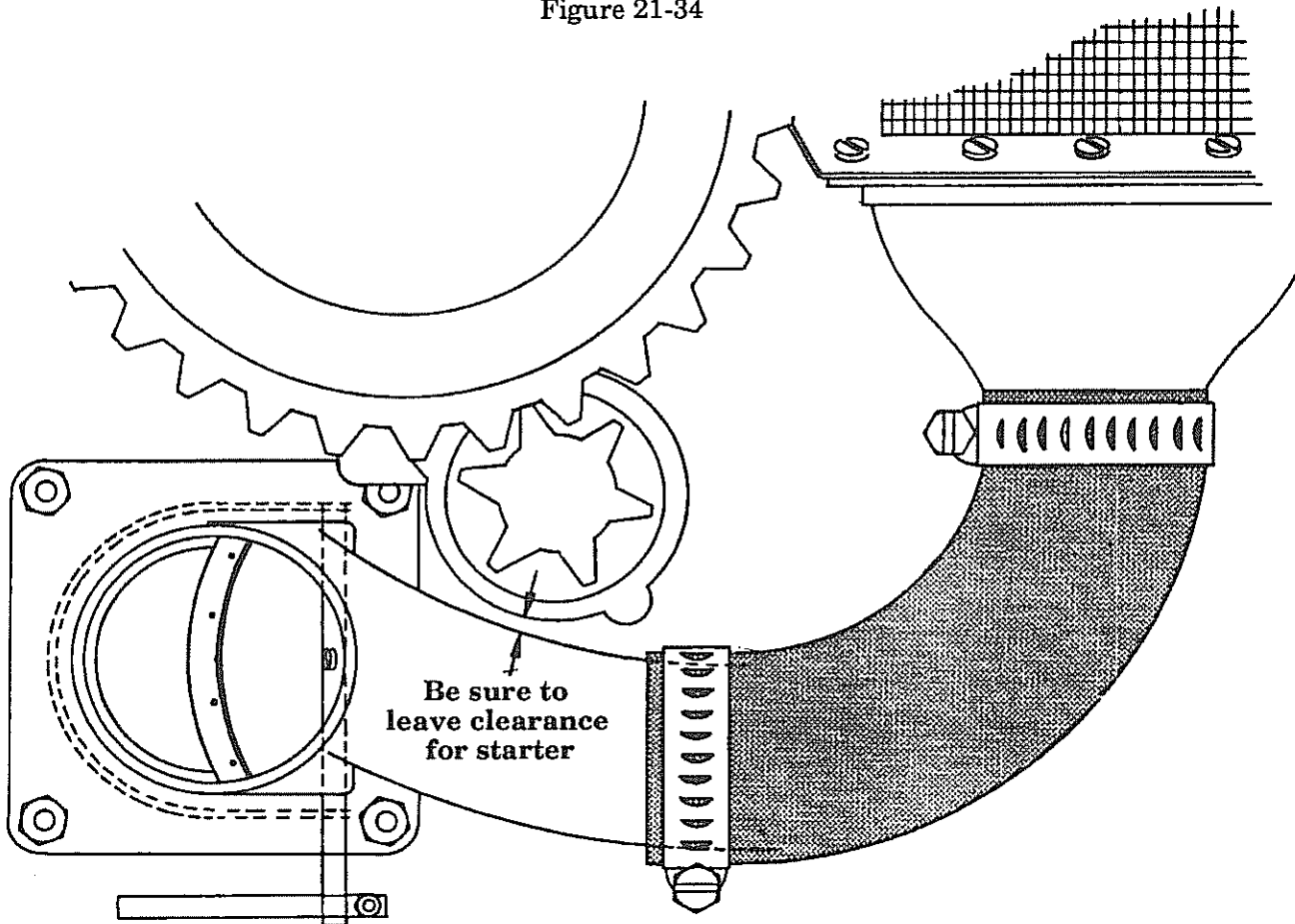

Be sure to leave clearance for starter

Selector valve shown in mid-position between ram and filtered air

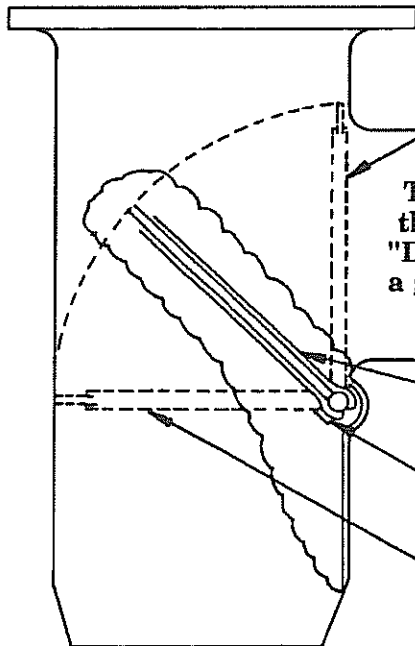

Valve position for ram air

The selector area of the chamber is made "D" shaped to provide a good sealing surface for the flapper

Selector vane is made by riveting a piece of the high temp flexible sealing material between two "D" shaped pieces of aluminum

These screws should be safety wired to prevent their possible absorption by your engine.

Valve position for filtered air

I.D. should be slightly larger than the cut-out on the cowling.

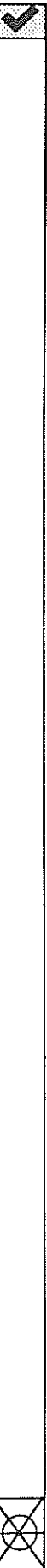

Ram airbox, with both carb heat and filtered air
Figure 21-35

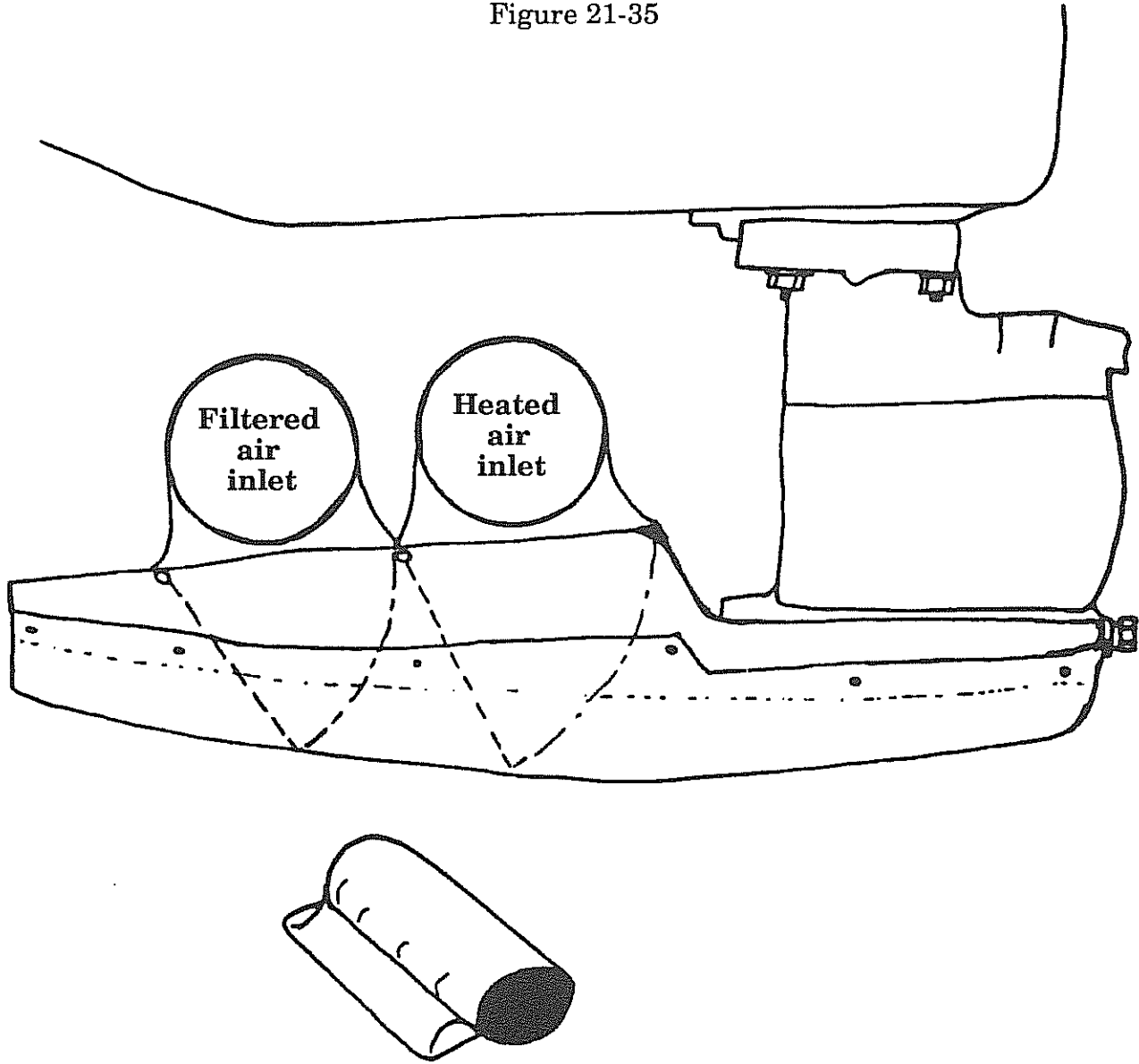

Propeller installation

Lancair 320's are designed for use with a constant speed prop, but fixed-pitch wood can be used (but you will have to get weight forward, i.e., battery next to firewall, etc.). If you are using a constant speed prop, use steps L1-7, then proceed to section N., spinner. If your choice is a fixed-pitch wood prop, proceed to installation steps M1 thru M9, then on to section N., spinner.

The most common choices are the constant speed models from Hartzell, (2 blade), and the MT 2 or 3 blade (the Hartzell 3 blade is too heavy). If you order the MT prop, get their back plate & spinner (we have spinners & backup plates for the Hartzell 2 blade).

L. Propeller installation, CONSTANT SPEED

1. Be sure that the mounting surfaces of the engine and prop flanges and the spinner backup plate are clean, as dirt will throw the prop out of alignment. Slip the spinner backup plate over the prop flange.
2. Place the starter ring assembly onto the motor flange, with the oversized stud in the oversized hole to properly orient your timing mark.
3. Prepare the prop 'bolts' by sliding the six studs through the extension flange from the rear, and thread the castle nuts onto them until the hole in the stud lines up with the slot in the castle nut, and then drive in the stainless steel pins.
4. Slip the spinner backup plate over the prop flange and, being careful not to damage the internal "O" -ring, slide the prop onto the motor flange. Once the prop is started on, it can then be snugged up by carefully tightening the bolts on a cross-rotation manner such that the prop is always kept 'square' to the flange. **DO NOT ALLOW THE PROP TO GET OUT OF SQUARE, THE DRIVE LUG HOLES IN THE PROP WOULD BECOME DAMAGED.**
5. With the prop snugged up, the proper torque must be established on the prop bolts.

THIS PROP TORQUE SETTING IS CRITICAL TO SAFE OPERATIONS. You'll have to check with the particular propeller maker for their recommended torque values as they will vary with each maker. In any case, the torque must not exceed the rated value for the bolts. Example: 7/16" bolts can be torqued up to 400-450 in/lbs, and 1/2" bolts to 550-600 in/lbs.

The torque technique is to rotate around the six bolt pattern such that you torque opposite bolt pairs. Once you've established the torque setting, go around and recheck each bolt again.

6. Safety wire the prop bolts using preferably 0.041" safety wire through the bolt head roll pins.

LANCAIR® 320FB

21-62

Chapter 21

REV.

0 / 11-1-91

ENGINE INSTALLATION - LYCOMING

7. After the first twenty (20) hours of flight the prop must be torque checked again. Subsequent checks should be made per the manufacturer's recommendations.



21-63

Chapter 21 REV. 0 / 11-1-91
ENGINE INSTALLATION - LYCOMING



M. Propeller, WOOD, FIXED-PITCH

Lancair 320's are designed for use with a constant speed prop, but wood fixed-pitch props can be used (but you will have to get weight forward, i.e., battery next to firewall, etc.).

1. If you use a wood prop, you must use a 4" prop extension (see figure 21-36). This will attach directly to the prop flange. Be sure that the flange and aft face of the extension are clean, as dirt under the extension will throw the prop out of alignment.
2. The AN6 prop extension mounting bolts must be safety wired through the heads. Torque values are 220-265 in/lbs for 3/8" bolts.
3. Next slip the spinner backup plate over the extension, again making sure that all surfaces are clean. Position the starter ring assembly in the motor flange, observing alignment of the oversized lug, to properly orient your timing mark.
4. Position the propeller by gently tapping on the hub section. The drive lugs often pose a snug fit into the prop hub so very gentle, back and forth, tapping is usually necessary.
5. Once the prop is started on, position the crush plate (**a crush plate is mandatory on wood props**) and insert the prop bolts. The prop can then be snugged up by carefully tightening the bolts in a cross-rotation manner such that the prop is always kept 'square' to the flange. **DO NOT ALLOW THE PROP TO GET OUT OF SQUARE, THE DRIVE LUG HOLES IN THE PROP WOULD BECOME DAMAGED.**

To properly track the prop, remove the upper spark plugs from the engine so that it can be easily turned over by hand. Torque the bolts to no more than 10 inch/pounds. Position something under the prop tip at its lowest point to mark the point at which it passes. Turn the prop through 180°, and see where the other blade passes the mark. Snug the bolts to bring the prop square to the plate, i.e., tighten the bolts on the side of the blade that passes the farthest forward. Keep tightening and checking, using no more than 25 inch/pounds until prop is running true and fully snugged down.

6. With the prop snugged up, the proper torque must be established on the prop bolts.

THIS PROP TORQUE SETTING IS CRITICAL TO SAFE OPERATIONS.

You'll have to check with the particular propeller maker for their recommended torque values as they will vary with each maker. In any case, the torque must not exceed the rated value for the bolts. Example: The Great American Propeller can be torqued up to 16 ft/lbs or 192 in/lbs.

The torque technique is to rotate around the six bolt pattern such that you torque opposite bolt pairs. Once you've established the torque setting, go around and recheck each bolt again.



7. Safety wire the prop bolts using preferably 0.040" safety wire through the bolt heads.
8. After the first half hour (30 minutes) of flight, the prop **MUST** be retorqued. The prop finish will usually crush a little thus lowering the torque values which were first set.
9. After the first ten (10) hours of flight the prop must be torque checked again. Subsequent checks should be made per the manufacturer's recommendations.



21-65

Chapter 21	REV.	0 / 11-1-91
ENGINE INSTALLATION - LYCOMING		



PROPELLER EXTENSION / PROP / SPINNER ASSEMBLY

For fixed pitch prop - side view

Figure 21-36

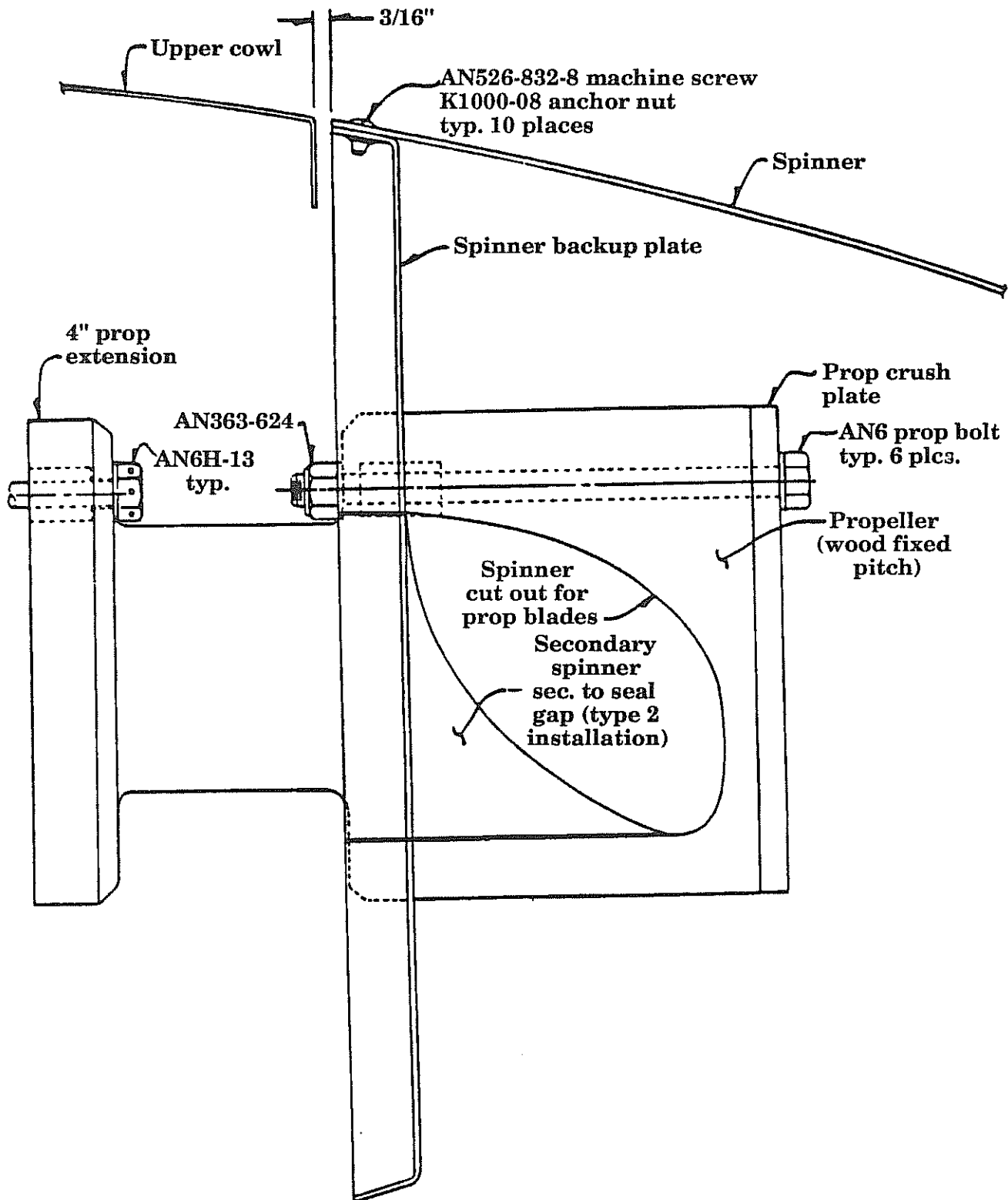

LANCAIR® 320FB

21-66

Chapter 21

REV.

0 / 11-1-91

ENGINE INSTALLATION - LYCOMING

N. Spinner

1. If you do not have a template for the prop blade cut out within the spinner, one will have to be made. Neico does have many templates available for various props.

You can make a pattern out of paper through a fit and check method using light carton board. Once a template is established, it must be transferred to the spinner by tracing a line with a pencil or pen. Be sure to allow for the thickness of the backup plate which is generally 3/4". Also be sure to position the template in the correct 'direction' on the spinner. You wouldn't be the first to make a beautiful cutout only to find that it will work *only* on a pusher plane!

NOTE: Constant speed props change pitch during operation - be sure your cutout includes space for the prop's pitch swing. There are two approaches to making the cutout shape. The first is perhaps the easiest but it leaves a rather sizeable gap between prop and spinner on the leading edge side. The other is a little more involved but generates a nice, consistently small, gap. They are both illustrated in figure 21-37. Figure 21-38 has a full-size template for the Neico spinner for a Hartzell 2 blade prop.

2. One acceptable method of cutting out the prop clearance in the spinner is with a hand sabre saw and a fine tooth blade. You will have to hold the spinner very firmly as you cut and support the spinner well close to the cutting line otherwise the whole thing will begin to jump up and down with the saw movements. Use a narrow chord blade so the radius can be cut smoothly. If you have trouble cutting around the fwd radius, cut short of the final mark and file to finish.
3. With the prop cutout completed and leaving at least 3/32" clearance all around the blade, the spinner is ready for mounting. Bolt the spinner backup plate to the propeller, installing the spacers evenly between the plate and the prop.
4. The best way to check that the spinner is correct is to rotate the engine and measure against a fixed pointer for spinner tip concentricity.

Place the spinner into position and secure with tape. Remove the upper spark plugs from the engine so you can spin it by hand without fighting compression. Place a fine tipped felt marker in a fixed position such that it just clears the forward tip of the spinner when positioned at the side. Turn the prop gently so as not to rock the plane and check for spinner concentricity. If it is out of alignment, the marker will mark a line at the point that is too far out from the center line. Adjust and recheck until the marker maintains equal clearances all the way through one revolution.



SPINNER CUTOUT

Figure 21-37

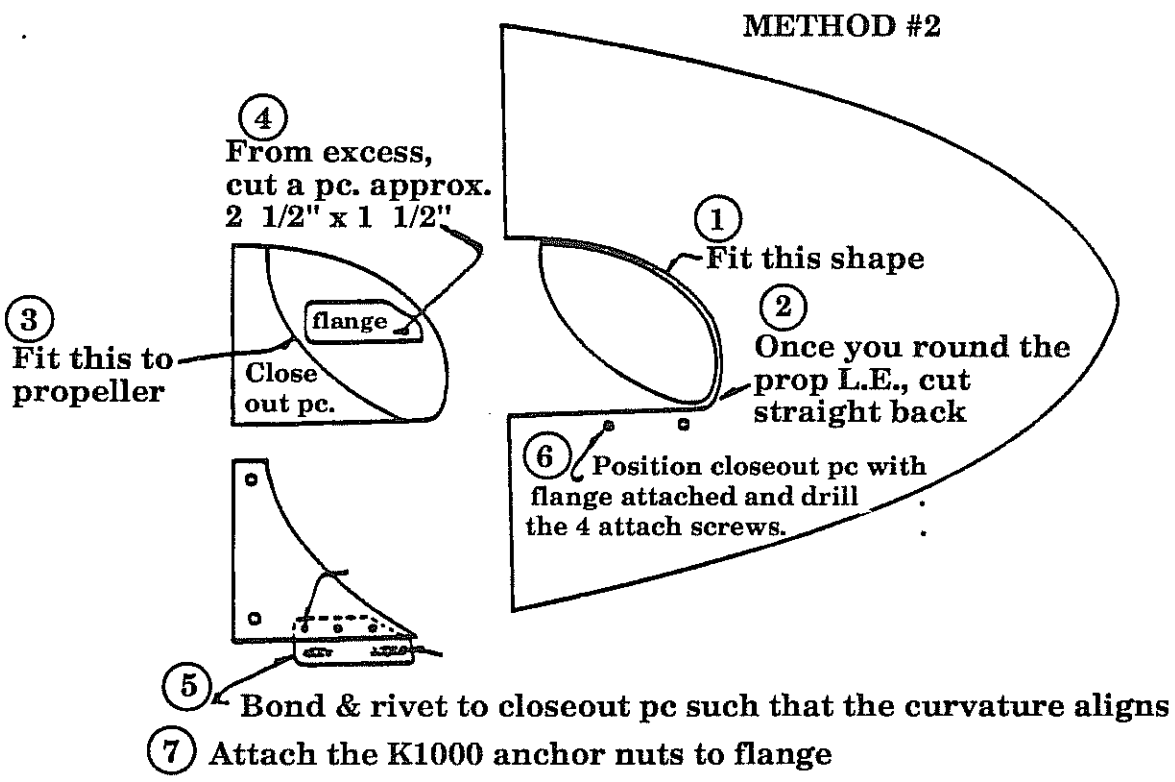
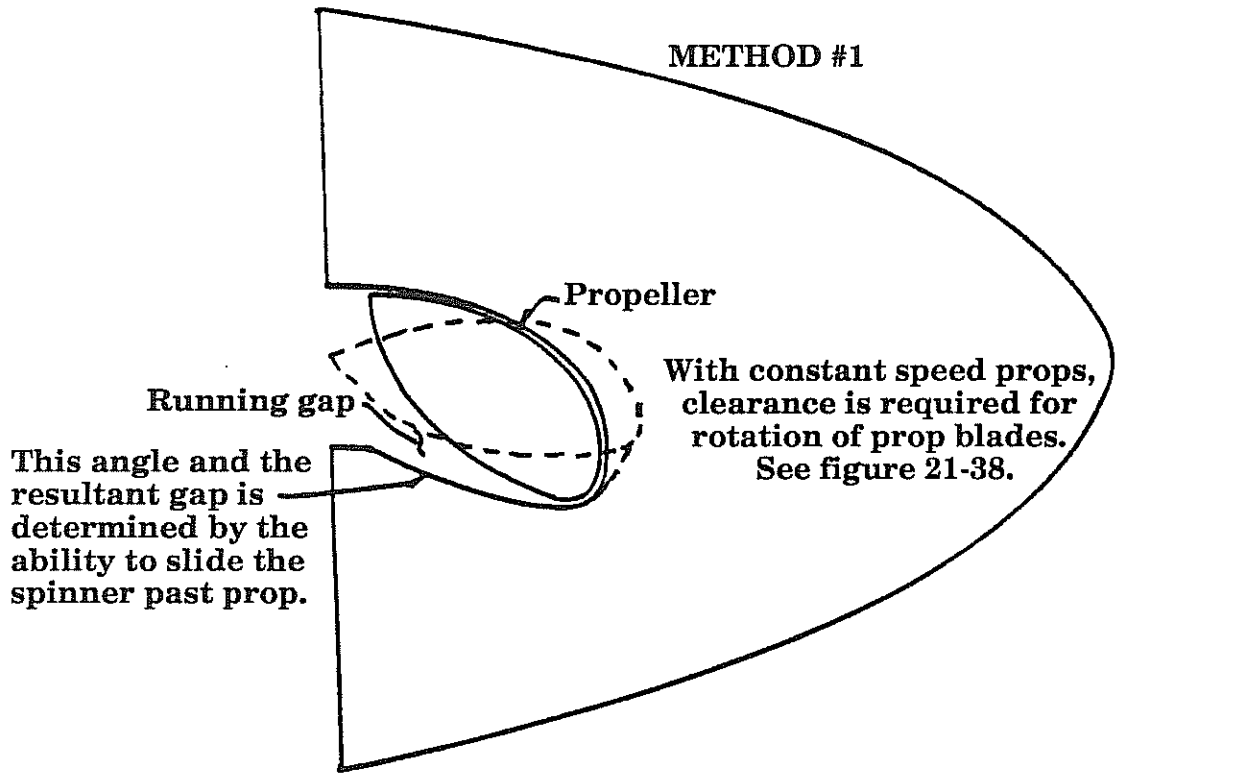

Another easier way (which is less accurate) is generally acceptable. Check for a scribe line on the aft edge of the spinner along the outside. If there is no scribe line, it can be assumed that the spinner is in fact trimmed exactly to the scribe line already. If you see any portion of the scribe line, sand lightly until a uniform distance is achieved or if only one side of the spinner shows a scribe line, sand until it is removed. This will then provide a 'true' spinner Trailing Edge. The T.E. can then be aligned with the T.E. of the back up plate and thus establish concentricity. This technique, although not truly 'exact' does seem to achieve satisfactory results when carefully performed.

5. With the spinner now ready for permanent attachment, secure in position (preferably with clamps).
6. The spinner should be attached with five (5) AN526-832-8 machine screws per side (AN526-1032-8 can also be used). Mark the locations along the circumference and mark the centers at approximately 0.350 fwd of the backup plate T.E.
7. Drill the center holes first using the appropriate bit (#19 for 832 or #12 for 1032). It is best to now place a temporary screw and plain nut through these holes. The remaining four screws per side should be drilled from center first moving outward towards the prop blades. Secure the spinner as you drill. In this manner, there will not be any 'buckling' tendency since the fit is 'worked out from the center'.
8. With all ten attachment holes drilled, remove the spinner and attach the K-1000 anchor nuts to the backup plate.
9. If you have chosen the second type of prop cutout, then the secondary gap filler must be added, see figure 21-37 Method 2. It will require 2 additional attachment screws on the backup plate and two along the spinner side (by the prop blade).

Make the overlapping attachment segment from a section of the piece cut out for the prop. Bond and rivet this piece to the filler piece with epoxy and three AN426-3-5 flat head rivets.



Hartzell 2 blade spinner cut-out template

Figure 21-38

FULL SIZE

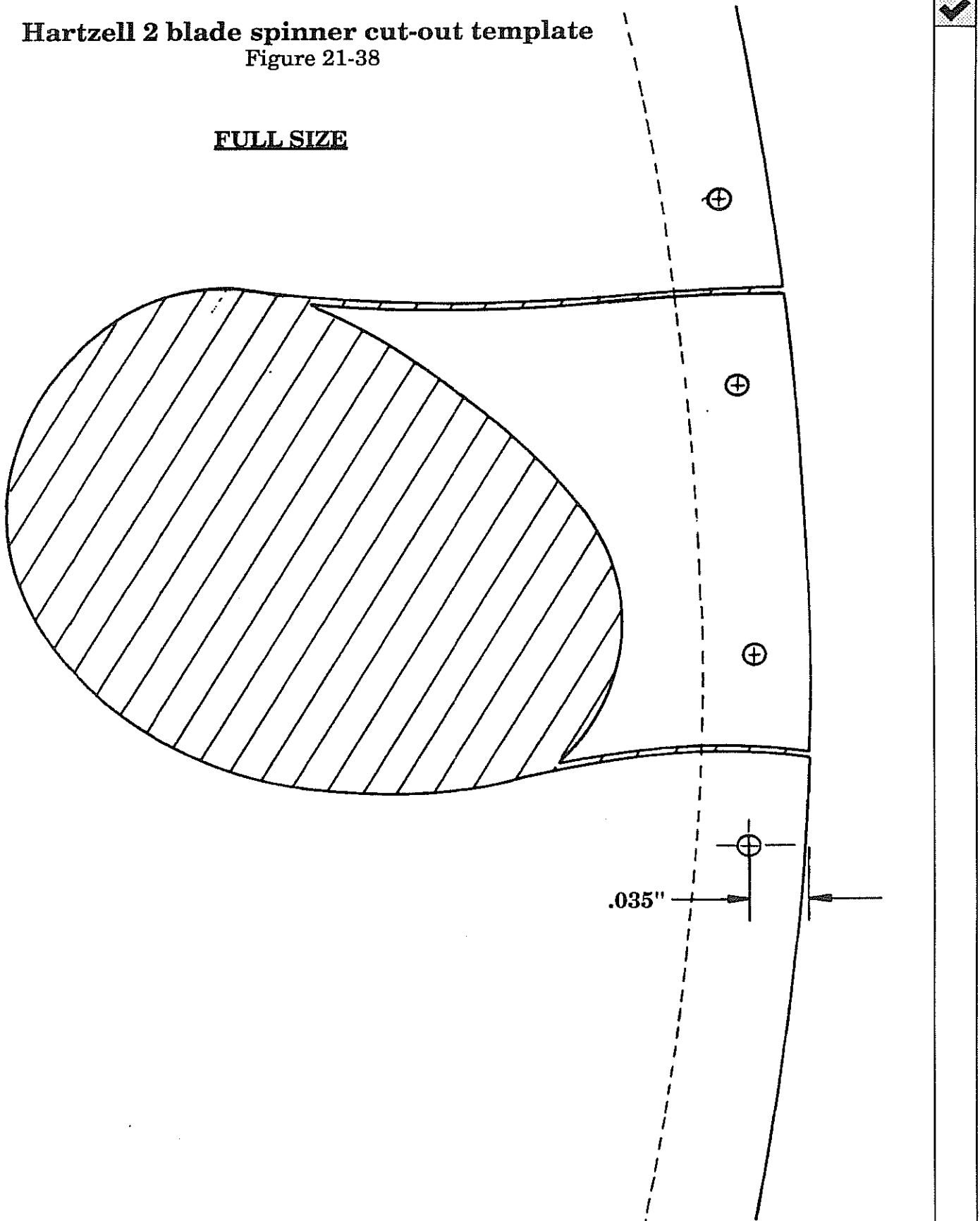

LANCAIR® 320FB

21-70

Chapter 21

REV.

0 / 11-1-91

ENGINE INSTALLATION - LYCOMING

- Hartzell 2 blade prop
- AN526-832-8 machine screw
- Spinner (10 plcs)
- K1000 anchor nut (10 plcs)
- Backup plate
- Spacers (as req'd)
- Hex head bolts (4 plcs)
- Prop bolts (6 plcs)
- Starter ring assembly
- Engine flange
- "O" ring, shaft
- Pressed inserts (6 plcs)

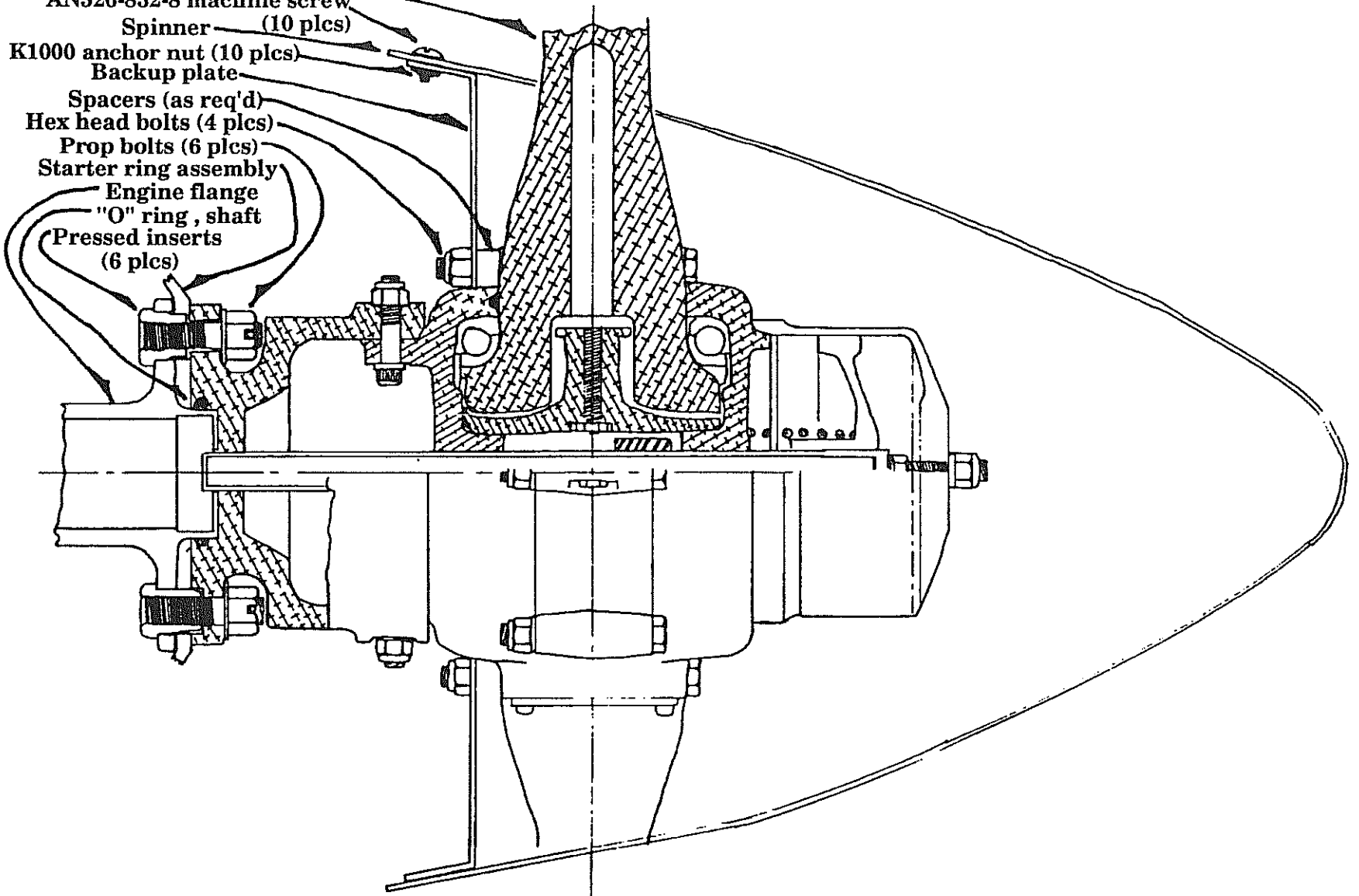

Hartzell 2 blade prop and spinner assembly
Figure 21-39



O. Tachometer

If you intend to use an electric tach then its location is not important beyond your personal preference. If you use a mechanical tach, there is one preferred location which allows for a good cable routing. This location is just right of the center radio stack, at the bottom of the panel, shown in figure 21-40. Generally a 40" tach cable works well but this will obviously be affected by your instrument panel FS location.

Mechanical tachometer location

Figure 21-40

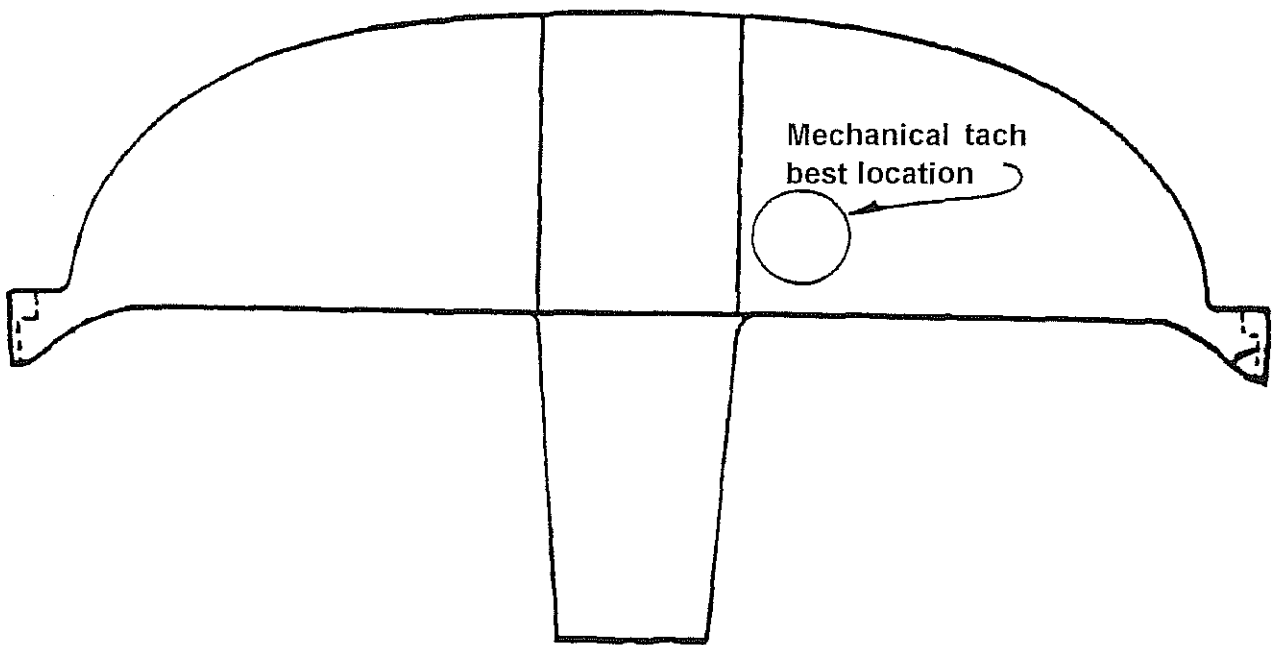



P. Miscellaneous Paperwork

It is important that you begin the registration process to receive your "N" number well in advance of completing your Lancair since this process can take up to three months to be completed. You will need to use the following FAA forms to complete this process:

- 8050-1 Aircraft Registration Application
- 8050-88 Affidavit of Ownership (you may use the one provided in this section)
- AC 8050-2 Aircraft Bill of Sale (if aircraft is purchased used)
- 8130-12 Notarized Eligibility Statement.

You should contact your local FAA Flight Standards District Office (FSDO) as some have developed packets which include all the paperwork needed for registration. You should also consult them on the application for the airworthiness certificate as they are very particular as to how this is to be filled out.

The builder of the aircraft may apply for a repairman certificate for his aircraft in accordance with FAR 65.104 using Advisory Circular AC65-23A. Having this certificate will allow the holder to maintain and repair the aircraft. This certificate may not, however, be transferred to another person if ownership of the aircraft should change in the future.

As you are going through the registration and inspection process, you may find it helpful to read both Advisory Circular 20-27D, Certification and Operation of Amateur-Built Aircraft, Advisory Circular 20-139, Commercial Assistance During Construction of Amateur-Built Aircraft, and Advisory Circular 90-89, Amateur-Built Flight Test Handbook.



21-73

Chapter 21

REV.

6/04-01-99

MISCELLANEOUS



The following instructions have been provided by the Federal Aviation Administration for identification number assignment and registration of amateur aircraft.

A U.S. identification number of the FAA's choice may be assigned, free of charge, to your amateur-built aircraft when you submit a complete description of the aircraft. The form titled "Affidavit of Ownership for Amateur-Built Aircraft" may be used as it meets the FAA requirements of both description and registration purposes. Authority to use a number assigned free of charge expires 90 days after the date it is issued unless the aircraft is registered within that period.

A U.S. identification number of your choice may be reserved, if available, for one year by sending a written request and a \$10 fee for each number to be reserved. Please list 5 numbers, in order of preference, in case your first choice is not available. If the number is not assigned to an aircraft prior to the end of the year, the reservation will expire, but may be renewed from year to year upon request and payment of a \$10 renewal fee.

NOTICE: The number may not be assigned or painted on an aircraft until approval is received from the FAA Registry Office.

Your written request to assign the reserved number to a particular aircraft must include a complete description of the aircraft. The "Affidavit" form may be used.

The items checked below are required to complete registration of your amateur-built aircraft:

- Completed and signed Aircraft Registration Application
- Registration fee of \$5.
- Affidavit of Ownership, signed before a notary public, and showing a description of the aircraft. The "Affidavit" form meets FAA requirements and may be used if you wish.

Mail the completed documents and registration fee of \$5 to:

Federal Aviation Administration Aircraft Registry
Mike Monroney Aeronautical Center
P.O. Box 25504
Oklahoma City, OK 73125



21-74

Chapter 21

REV.

6/04-01-99

MISCELLANEOUS



SAMPLE LETTER REQUESTING SPECIFIC N NUMBER



FAA Aircraft Registry
Department of Transportation
P.O. Box 25082
Oklahoma City, OK 73125

Gentlemen:

I request that a Special identification number be assigned to my amateur built aircraft. This aircraft has not previously been registered anywhere.

Any of the following numbers would be acceptable (listed in order of preference):

- 1. N _____
- 2. N _____
- 3. N _____
- 4. N _____
- 5. N _____

Enclosed is my check for \$10 and an affidavit of ownership which describes the aircraft.

Sincerely,



	21-75	Chapter 21	REV. 6/04-01-99
		MISCELLANEOUS	

SAMPLE LETTER REQUESTING THE FAA ASSIGN N NUMBER

FAA Aircraft Registry
Department of Transportation
P.O. Box 25802
Oklahoma City, OK 73125

Gentlemen:

I request that a U.S. Identification number of your own choice be assigned to my amateur built aircraft.

An affidavit of ownership and description of the aircraft is enclosed. This aircraft has not previously been registered anywhere.

Sincerely,



21-76

Chapter 21	REV.	6/04-01-99
MISCELLANEOUS		



AFFIDAVIT OF OWNERSHIP FOR AMATEUR-BUILT AIRCRAFT



U.S. Identification Number _____

Builder's Name _____

Model _____

Serial Number (required) _____

Class (airplane, rotorcraft, glider, etc.) _____

Type of Engine Installed _____

Manufacturer, Model, and Serial Number of each Engine Installed _____

Built for Land or Water Operation _____ Number of Seats _____

The above described aircraft was built from parts, and I am the owner.
Address _____

City _____ State _____ Zip Code _____

Telephone: Home (____) _____ Work _____

(Signature of Owner)

State of _____

County of _____

Subscribed and sworn to before me this _____ day of _____ 19 _____

My commission expires _____

(Signature of Notary Public)



21-77

Chapter 21

REV. 6/04-01-99

MISCELLANEOUS



How to Register Your Lancair (in the United States)



There is a certain amount of paperwork which must be completed prior to the FAA doing a final inspection on your aircraft and issuing an airworthiness certificate. You may find the following definitions helpful when preparing your paperwork:

Airworthiness - The state or quality of an aircraft or of an aircraft component which will enable safe performance according to specifications.

Airworthiness Certificate - A document which shows that an aircraft meets the safety requirements of the FAA.

Registration Certificate - A document which must be displayed in a U.S. civil aircraft showing the owner as being registered with the FAA. An aircraft is eligible for registration only if it is owned by a citizen of the United States, and not registered under the laws of a foreign country.

Pilot's Operating Handbook - A handbook which typically gives information about the aircraft in the following areas:

- Aircraft Dimensions and Specifications
- Engine Specifications
- Limitations
- Emergency Procedures
- Normal Procedures
- Performance
- Weight and Balance
- Airplane and Systems Descriptions
- Airplane Handling, Service and Maintenance

This Pa - A record of the distribution of weight in an aircraft and the determination of the center of gravity (CG) at takeoff and landing.



21-78

Chapter 21

REV.

6/04-01-99

MISCELLANEOUS



Final Inspection Checklist



The purpose of this guide is to offer advice and guidance for the final inspection of the aircraft and to assist in the planning and preparation for flight testing your Lancair. You have invested many hours and much money in your aircraft, and all that can be lost in a matter of seconds without proper preparation and knowledge for the first flight.

Many requirements must be met prior to first flight. All FAA inspection(s), airworthiness certificate, registration, weight and balance, pilot qualification, placards, logbooks, restrictions, etc., should be completed prior to any testing. It is too easy to become airborne while taxi testing so do all the paperwork first. The EAA has many publications to assist in this preparation, and these are highly recommended.

We have assembled an exhaustive checklist to provide a system for checking all nuts, bolts, fittings, safety wire, cotter pins, systems, etc. Unlike a normal pre-flight inspection, this checklist follows a system-by-system approach. The intent is to make you think about the entire system that you are checking and to make certain that nothing has been overlooked.

Whatever you do, the most important thing to do is think. While you are inspecting a system (flight controls, for example) think about what the system is supposed to do. Look for any reason that the system might not function as intended.

While no checklist can ensure that you built the aircraft correctly, there are certain things that should be paramount in your mind. Cotter pins and safety wire are incredibly important. They are tiny things that are always a pain-in-the-rear to install, so it is quite possible that you did not install all of them. A missing cotter pin is an accident looking for a time to happen. Over the history of aviation there have already been way too many pilots and aircraft that have come to grief because a cotter pin was left out; don't add your name and N number to the list.

A review of the statistics of accidents involving experimental aircraft shows that engine failures play a role in one out of three, and fuel system problems are most often cited as the cause. These problems include fuel contamination, obstructed fuel vents, fuel system leaks, and fuel mismanagement. Thus, you should exercise extreme care to ensure the proper operation of the fuel system before any flight is attempted. Even after the aircraft is in the air, you should stay within the gliding range of the airport until you have absolute confidence that the fuel system is working properly.



21-79

Chapter 21

REV.

6/04-01-99

MISCELLANEOUS



